

# GM62093A

## 12×8 CROSSPOINT SWITCH WITH CONTROL MEMORY

### Description

The GM62093A contains a 12×8 array of crosspoint together with a 7 to 96 Line decoder and latch circuits. The GM62093A employs LG's advanced high voltage CMOS process technology. It provides extra low operating current and low power dissipation. Anyone of the 96 switches can be addressed by selecting the appropriate 7 input bits. The selected turned on or off by applying a logical one or zero to the data in and the strobe input at logical one. A reset signal can be used to turn off all the switches together when is switched at logical one. The GM62093A is avail-able in a 40 lead dual in-line plastic and ceramic package.

### Feature

- CMOS 12×8 Cross Point Switch with Control Memory
- Low On Resistance
- Internal Control Latches
- DRon 15Ω Max
- Less Than 1% Total Distortion at 0 dbm
- Extra Low Operating Current
- Extra Low Cross-Talk Between Any Two Switches
- Standard CMOS Noise Immunity
- TTL Compatible Input

### Block Diagram

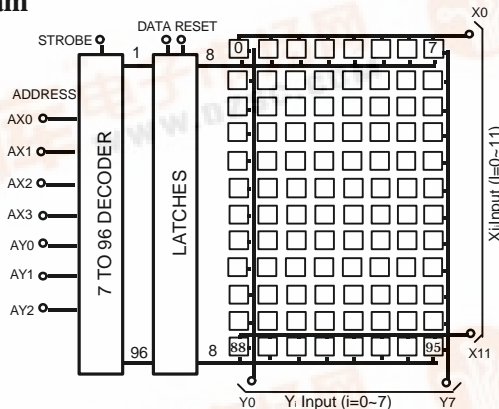

### Pin Configuration

(Top View)

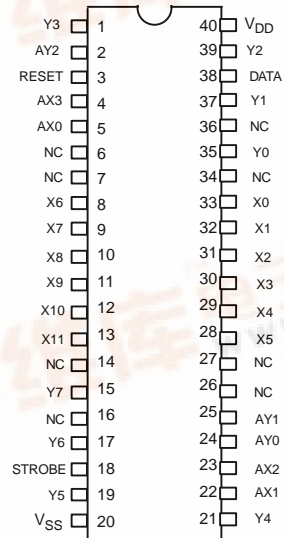

### Application

- PBX Systems
- Mobile Radio
- Test Equipment Instrumentation
- Analog/ Digital Multiplexer



**Absolute Maximum Rating**

SYMBOL	PARAMETER	MIN	MAX	UNIT
$V_{DD}$	DC Supply Voltage	-0.5	18	V
$V_{IN}$	Input Voltage Range	-0.5	$V+0.5$	V
$I_{IN}$	DC Input current		$\pm 10$	mA
P(P-DIP) (C-DIP)	Power Dissipation		0.6 1	W
$T_{OPR}$	Operation Temperature Range	0	70	°C
$T_{STG}$	Storage Temperature Range	-65	150	°C

**Recommended Operating Range**

SYMBOL	PARAMETER	MIN	MAX	UNIT
$V_{DD}$	DC Supply	8	16	V
$V_{IN}$	Input Voltage Range	0	$V_{DD}$	V
$T_{OPR}$	Operation Temperature Range	0	70	°C

**Static Electrical Characteristics: ( $T_A = 0^\circ\text{C}$  to  $70^\circ\text{C}$ ,  $V_{CC} = 14\text{V}$ )**

SYMBOL	PARAMETER	TEST CONDITION	MIN	TYP	MAX	UNIT
CROSS POINT						
$I_{DD}$	Quiescent Supply Current	All Digital Input at $V_{SS}$ or $V_{DD}$			100	$\mu\text{A}$
		All Digital Input at 2.4 V		7	15	mA
Ron	On Resistance	$V_{DD} = 3.5\text{V}$ and $I(\text{thru S/W})=10\text{mA}$			65	$\Omega$
Ron	Ron Difference Between Any Two Switches				15	$\Omega$
Asc	Analog Signal Capability	$V_{DD} = 14\text{V}$ All Switchs On $V_{is} = 14\text{V}$ and $I(\text{thru S/W}) = -100\mu\text{A}$	13.96		14.0	V
$I_{LOFF}$	Off Leakage	All Switch off $V=V=0$ to V			$\pm 500$	nA
CONTROLS						
$V_{IL}$	Input Low Voltage				0.8	V
$V_{IH}$	Input High Voltage		2.4			V
$I_{LEAK}$	Input Leakage	$V_{IN} = 0$ to $V_{DD}$			$\pm 500$	nA

**Dynamic Electrical Characteristics :** ( $T_A = 25^\circ\text{C}$ ,  $C_L = 50\text{pF}$ ,  $V_{DD} = 14\text{V}$ )

SYMBOL	PARAMETER	TEST CONDITION	MIN	TYP	MAX	UNIT
CROSS POINT						
$t_P$	Propagation Delay Time	$R_L = 1\text{k}\Omega, V_{DC} = 5\text{V}$ $V_{IS} = 2V_{PP}$			30	NS
$f_{RES}$	Frequency Response [ $20\log(V_{OUT}/V_{IN})=-3\text{dB}$ ]	$R_L = 1\text{k}\Omega, V_{DC} = 5\text{V}$ $V_{IS} = 2V_{PP}, C_L = 3\text{pF}$		40		MHz
	Sine Wave Response(Distortion)	$R_L = 1\text{k}\Omega, V_{DC} = 5\text{V}, V_{IS} = 2V_{PP}, f = 1\text{MHz}$			1	%
	Feedthrough (All S/W's Off)	$R_L = 1\text{k}\Omega, V_{DC} = 5\text{V}, V_{IS} = 2V_{PP}, f = 10\text{KHz}$			-80	dB
	Crosstalk Between Any Two Channels	$R_S = 50\Omega, R_L = 1\text{k}\Omega, V_{IS} = 2V_{PP}, f = 1\text{KHz}$		-110	-95	dB
$C_X$	Capacitance (XN to Ground)	Switch Off			20	pF
$C_Y$	Capacitance (YN to Ground)	Switch Off			30	pF
$C_{DI}$	Digital Input Capacitance			5		pF
CONTROL						
$t_{DS}$	Strobe to Switch Delay	$R_L = 1\text{k}\Omega, t_r = t_f = 20\text{nS}$			160	nS
$t_{DD}$	Data to Switch Delay	$R_L = 1\text{k}\Omega, t_r = t_f = 20\text{nS}$			180	nS
$t_{DA}$	Address to Switch Delay	$R_L = 1\text{k}\Omega, t_r = t_f = 20\text{nS}$			200	nS
$t_{DR}$	Reset to Switch Delay	$R_L = 1\text{k}\Omega, t_r = t_f = 20\text{nS}$			200	nS
$t_{SD}$ $t_{SA}$	Data Setup Time Address Setup Time	$R_L = 1\text{k}\Omega, t_r = t_f = 20\text{nS}$	30			nS
$t_{HD}$ $t_{HA}$	Data Hold Time Address Hold Time	$R_L = 1\text{k}\Omega, t_r = t_f = 20\text{nS}$	30			nS
$t_{SW}$ $t_{RW}$	Minimum Strobe Pulse Width Minimum Reset Pulse Width	$R_L = 1\text{k}\Omega, t_r = t_f = 20\text{nS}$	200			nS

**Functional Description**

The GM62093A contains a  $12 \times 8$  array of analog switches, each with a latch to maintain its on(closed)or off(opened) state.

Seven ADDRESS lines (AX0~AX3, AY0~AY2) are provided to address any one of the 96 switches.

After any one of the switches is selected, the

DATA pin may be held high to turn the switch on, or low to turn it off.

Finally a positive pulse to the STROBE pin initiates the ac-tion determined by the ADDRESS and DATA pins. All 96 switches can be turned off by forcing the RESET pin high.

**Timing Diagram**

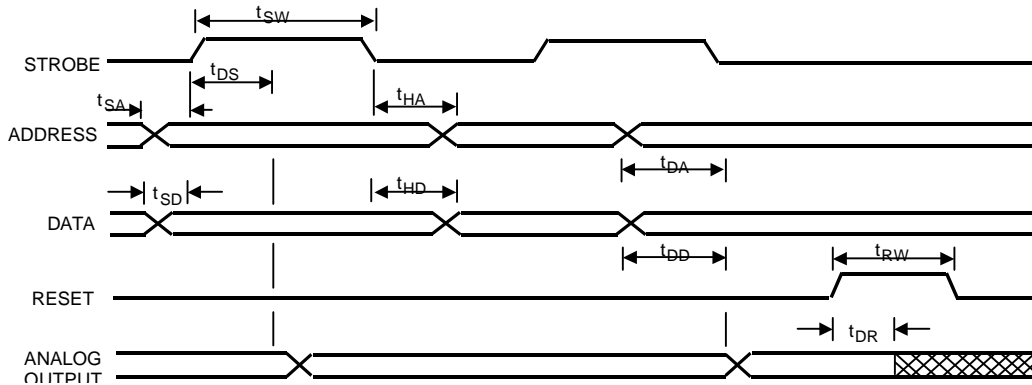

**Truth Table**

Address							Connections
AX0	AX1	AX2	AX3	AY0	AY1	AY2	
0	0	0	0	0	0	0	X0-Y0
1	0	0	0	0	0	0	X1-Y0
0	1	0	0	0	0	0	X2-Y0
1	1	0	0	0	0	0	X3-Y0
0	0	1	0	0	0	0	X4-Y0
1	0	1	0	0	0	0	X5-Y0
0	0	0	1	0	0	0	X6-Y0
1	0	0	1	0	0	0	X7-Y0
0	1	0	1	0	0	0	X8-Y0
1	1	0	1	0	0	0	X9-Y0
0	0	1	1	0	0	0	X10-Y0
1	0	1	1	0	0	0	X11-Y0
0	0	0	0	1	0	0	X0-Y1
↓	↓	↓	↓	↓	↓	↓	↓
1	0	1	1	1	0	0	X11-Y1
0	0	0	0	0	1	0	X0-Y2
↓	↓	↓	↓	↓	↓	↓	↓
1	0	1	1	0	1	0	X11-Y2
0	0	0	0	1	1	0	X0-Y3
↓	↓	↓	↓	↓	↓	↓	↓
1	0	1	1	1	1	0	X11-Y3
0	0	0	0	0	0	1	X0-Y4
↓	↓	↓	↓	↓	↓	↓	↓
1	0	1	1	0	0	1	X11-Y4
0	0	0	0	1	0	1	X0-Y5
↓	↓	↓	↓	↓	↓	↓	↓
1	0	1	1	1	0	1	X11-Y5
0	0	0	0	0	1	1	X0-Y6
↓	↓	↓	↓	↓	↓	↓	↓
1	0	1	1	0	1	1	X11-Y6
0	0	0	0	1	1	1	X0-Y7
↓	↓	↓	↓	↓	↓	↓	↓
1	0	1	1	1	1	1	X11-Y7

A<sub>x</sub> = 0110, 1110, 0111 and 1111 and not allowed

Test circuit and Characteristics.

Fig.1-Crosstalk

● TEST CIRCUIT

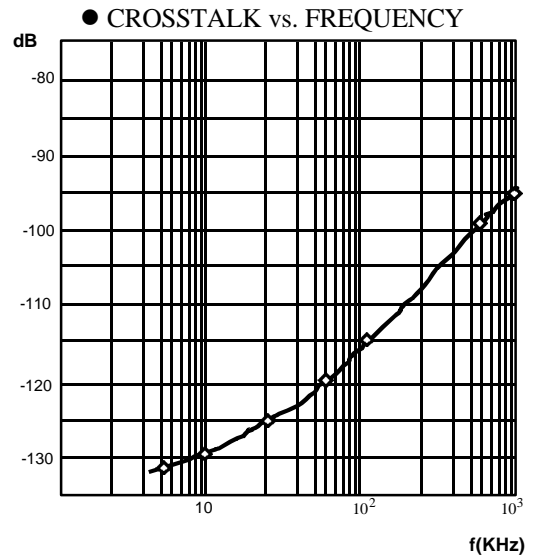
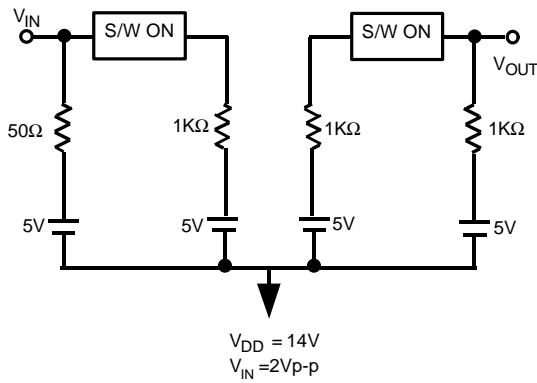
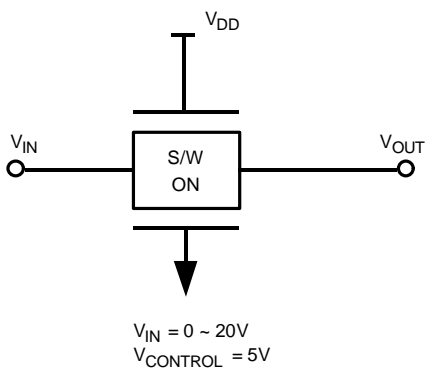

Fig.2 –analog signal capability(V<sub>in</sub> vs. V<sub>out</sub>)

● TEST CIRCUIT



● RESULT

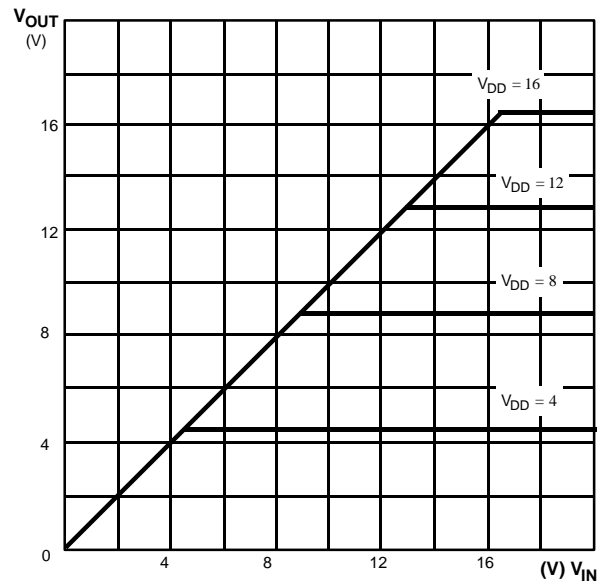
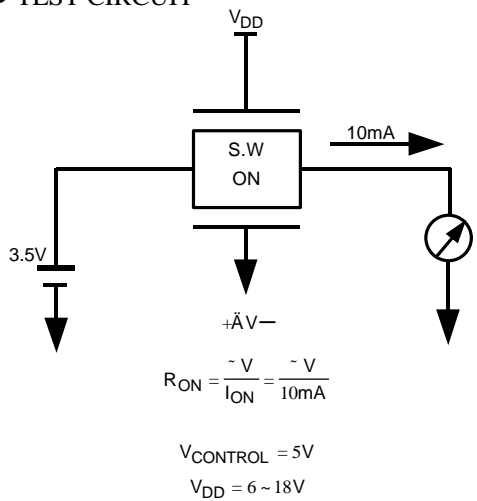

Fig.3-Ron measurement

● TEST CIRCUIT



● RESULT

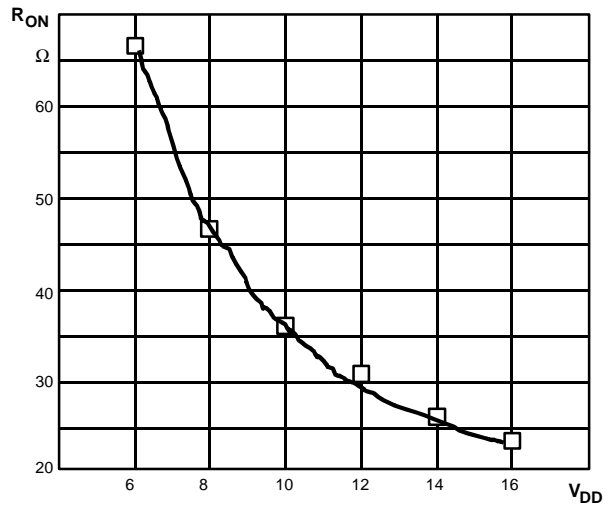
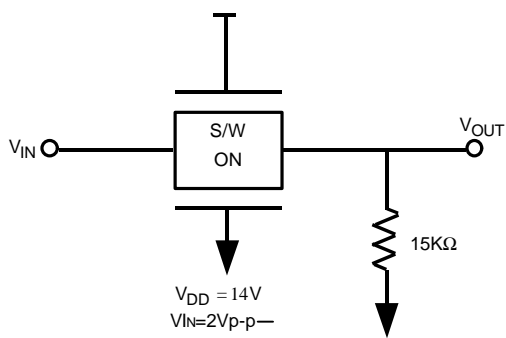

Fig.4-Frequency response.

● TEST CIRCUIT



● BANDWIDTH

(-3dB point: ABOUT 45MHz)

