



GENNUM
CORPORATION

HD-LINX™ G01515
Voltage Controlled Oscillator

DATA SHEET

FEATURES

- generates 1.485GHz or 1.485/1.001GHz signal for HD-LINX™ ICs
- low current consumption
- 50Ω output impedance
- operates from a single 5V supply
- 8 pin tape on reel

APPLICATIONS

VCO for the following HD-LINX™ ICs: GS1515, GS1522, GS1540, GS1545.

ORDERING INFORMATION

PART NUMBER	PACKAGE	TEMPERATURE
GO1515 - CTA	8 pin tape on reel	0°C to 70°C

DESCRIPTION

The GO1515 is a self contained, miniature Voltage Controlled Oscillator (VCO) that is used in conjunction with Gennum's HD-LINX™ ICs. It produces a clean 1.485GHz reference clock signal for such devices as the GS1515 HDTV Reclocker and other HD-LINX™ devices. The control voltage range is from 3.10 volts to 4.65 volts and is derived from the on-chip PLLs. The GO1515 frequency can be pulled approximately 16MHz for every one volt of control.

The output level is approximately 1.0dBm with low spurious and noise content. It is designed to drive 50Ω strip lines.

The GO1515 VCO is used with the following HD-LINX™ ICs; GS1515, GS1522, GS1540, GS1545 and is ordered as a separate item. The VCO requires a single 5V supply and draws a maximum of 15mA of current. It is packaged in a miniature 8-pin proprietary surface mount package and operates over the normal commercial temperature range of 0°C to +70°C.

GO1515

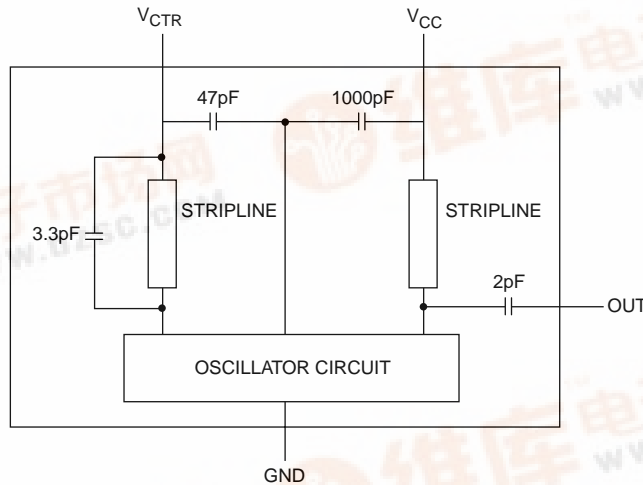

BLOCK DIAGRAM



ELECTRICAL CHARACTERISTICS

$V_S = 5.0V \pm 0.25V$, Temperature = $0^\circ C$ to $70^\circ C$ unless otherwise specified.

PARAMETER	SYMBOL	CONDITIONS	MIN	TYP	MAX	UNITS
Supply Voltage	V_{CC}		4.75	5.0	5.25	V
Supply Current	I_S		-	-	15	mA
Control Voltage Range	V_{CTR}		+3.1	-	+4.65	V
Control Voltage Sensitivity	df/dV		11	16	21	MHz/V
Operating Frequency Range	f_{VCO}		1483.5	-	1485.5	MHz
Output Signal Level	V_{OUT}		-2	1	+4	dBm
Signal to Noise Ratio	S/N	Signal Level: 1kHz \pm 8kHz Deviation = 0.3~3.0kHz	40	-	-	dB
Carrier to Noise Ratio	C/N	25kHz Separation, 1kHz Bandwidth	74	-	-	dBc
Pushing Figure		$V_S = 5.0V \pm 0.25V$, ref: $V_S = 5.0V$	-	± 500	-	kHz
Pulling Figure		VSWR = 2.0 for all phase, ref: 50Ω	-	± 1000	-	kHz
Temperature Stability	T_{COEF}	$0^\circ C$ to $70^\circ C$, ref. = $25^\circ C$	-	-	± 3	MHz
Spurious Response			-	-	-10	dBc
Output Impedance	Z_O		-	50	-	Ω

PIN CONNECTIONS

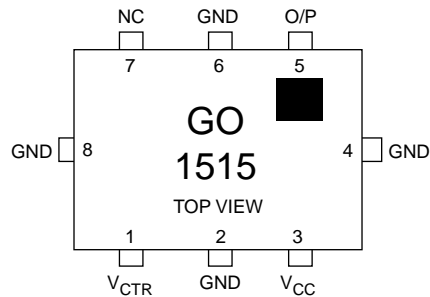

NOTE: Pin numbers are arbitrary.
There are no pin markings on the device itself

PIN DESCRIPTIONS

NUMBER	SYMBOL	TYPE	DESCRIPTION
2, 4, 6, 8	GND	-	Most negative power supply connections.
1	V_{CTR}	I	Control voltage for the VCO.
3	V_{CC}	-	Most positive power supply connection.
5	O/P	O	VCO signal output.
7	NC	-	No connection.

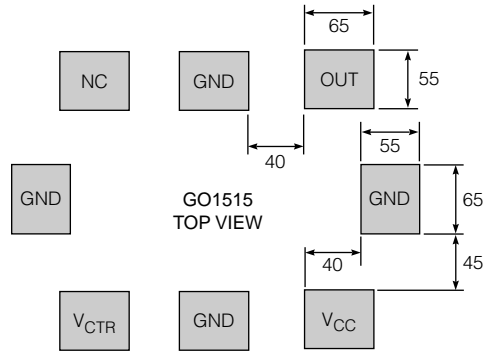

All dimensions are in mils
1 mil = 1/1000 inch

Fig. 1 Footprint of the GO1515

DIMENSIONS

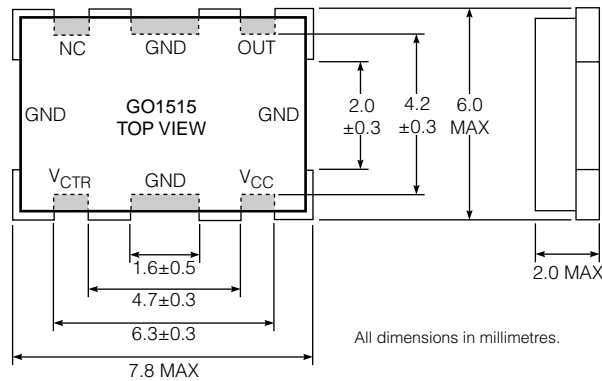

All dimensions in millimetres.

SOLDERING RECOMMENDATIONS

Reflow Conditions

The device will meet the data sheet specifications after completing the reflow process according to the profile shown in Figure 3. Do not reflow the device more than twice.

Endurance To Warp

When the device is soldered on a printed circuit board (dimension: 100mm x 100mm; thickness: 1.6mm) and the PCB is warped as shown in Figure 2, the device will not be cracked or damaged.

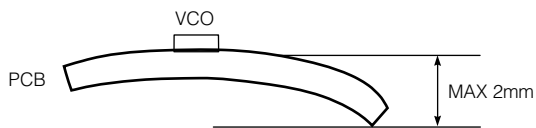

Fig. 3 PCB Warp

Soldering Conditions

Recommended soldering conditions are as follows:

Reflow Soldering

- Preheating 150±10°C, 60 to 120 sec.
- Soldering Peak 230±5°C
Over 200°C within 30 sec.

Soldering Flux

Do not use cleaning type flux. Washing the devices after using cleaning type flux may damage inner parts and affect performance.

Solder Type

Use solder H60, H63 (in JIS Z 3282) or an equivalent type. This also applies to solder paste.

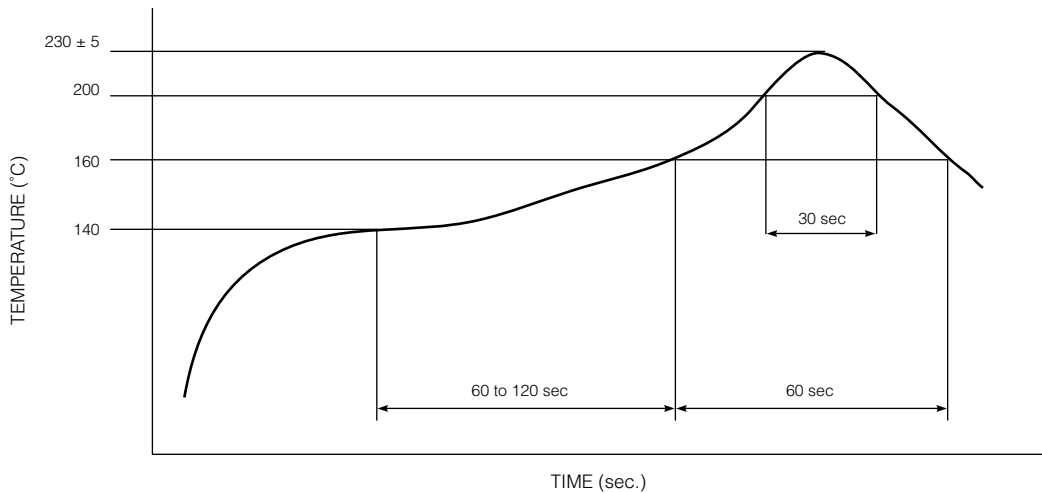

Fig. 3 Reflow Profile

HANDLING RECOMMENDATIONS

Cleaning

Do not wash the devices.

Storage

Store the devices out of direct sunlight, at a stable temperature and humidity. Avoid extreme temperatures, high humidity and wide temperature fluctuations. Condensation on the devices may result in reduced quality and lowered solderability.

Use within 6 months after delivery. If the devices are stored for more than one year, solderability may be degraded.

Avoid dust, sea breezes and corrosive gases (Cl₂, NH₃, SO₂, NO_x, etc.).

<p>CAUTION ELECTROSTATIC SENSITIVE DEVICES DO NOT OPEN PACKAGES OR HANDLE EXCEPT AT A STATIC-FREE WORKSTATION</p>	
--	--

<p>DOCUMENT IDENTIFICATION DATA SHEET The product is in production. Gennum reserves the right to make changes at any time to improve reliability, function or design, in order to provide the best product possible.</p>

<p>REVISION NOTES: Added Soldering and Handling sections and figures. <i>For latest product information, visit www.gennum.com.</i></p>
--

GENNUM CORPORATION
MAILING ADDRESS:
P.O. Box 489, Stn. A, Burlington, Ontario, Canada L7R 3Y3
Tel. +1 (905) 632-2996 Fax. +1 (905) 632-5946

SHIPPING ADDRESS:
970 Fraser Drive, Burlington, Ontario, Canada L7L 5P5

GENNUM JAPAN CORPORATION
C-101, Miyamae Village, 2-10-42 Miyamae, Suginami-ku
Tokyo 168-0081, Japan
Tel. +81 (03) 3334-7700 Fax. +81 (03) 3247-8839

GENNUM UK LIMITED
25 Long Garden Walk, Farnham, Surrey, England GU9 7HX
Tel. +44 (0)1252 747 000 Fax +44 (0)1252 726 523