



# TECHNICAL DATA

AN EXCLUSIVE RADIO SHACK® SERVICE TO THE EXPERIMENTER

## GP1U52X INFRARED RECEIVER/DEMODULATOR

### Features:

- Rejects all sources not modulated at 40kHz for reliable operation
- Compact size for miniature applications
- Operates from 5V, making direct connection to TTL or CMOS components easy
- Coil-free design provides total immunity from external noise induced by magnetic fields
- Built-in low-pass filter on the power supply helps isolate the circuitry from power supply noise

### General Description

The GP1U52X Infrared Receiver/Demodulator is a hybrid IC/infrared detector circuit designed for use as a highly reliable infrared detector for televisions, VCRs, audio components, and so on. It is also ideal as a low-cost detector for hobbyist applications.

The GP1U52X uses a pin photo diode that has its peak sensitivity in the near infrared range. The built-in filter blocks visible light to reduce or eliminate false operation caused by other light sources.

The output of the photo diode feeds into a preamplifier/limiter to provide a clean signal to the rest of the circuit. The band pass filter then rejects all signals outside the pass band (40 kHz +/- 4kHz). The remaining signal is fed to the demodulator, integrator, and wave-shaper circuit (see the Block Diagram). The output is a clean waveform without the carrier.

### Package Outline

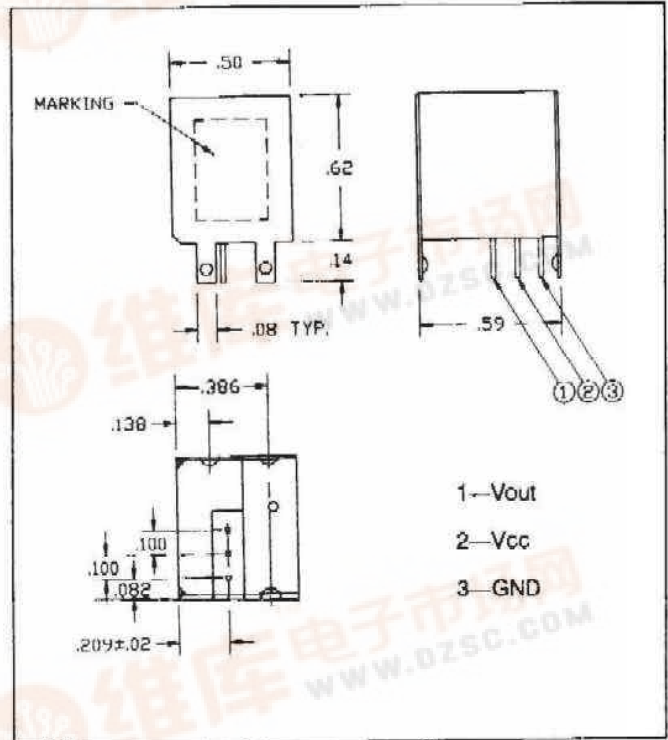

- 1—Vout
- 2—Vcc
- 3—GND

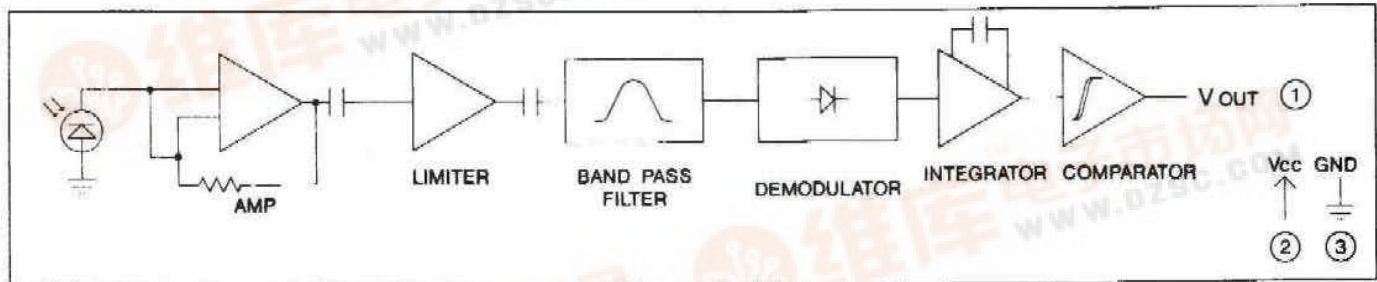

### Block Diagram

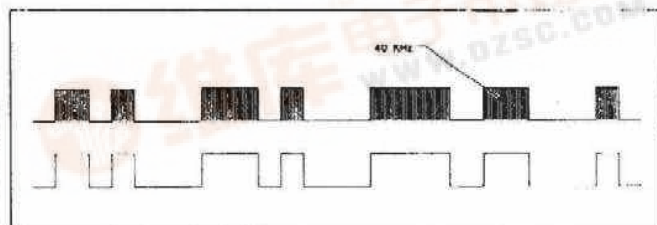

Timing Diagram

### Specifications

Maximum Supply Voltage.....	6.3V
Recommended Operating Voltage.....	5.0V +/-0.3V
Current Dissipation (ICC).....	5.0mA
Bandpass Center Frequency.....	40 kHz
-3dB Band Width of 40 kHz.....	4 kHz
Infrared Passband.....	980 nm +/- 100 nm



## SAMPLE APPLICATION

The following presents a sample transmitter and receiver circuit incorporating the GP1U52X. The transmitter circuit uses two timers (both sides of a 556 Dual Timer) to drive an infrared LED and transmit a tone. The receiver uses a 567 Tone Decoder to provide an on/off indication when you activate the transmitter.

Set the first timer in the 556 to oscillate at from 100 to 1000 Hz. The output of this timer then inhibits the running of the second timer, which is set to oscillate at 40kHz. The output of the second timer drives an infrared LED.

The output of the GP1U52X drives a simple one-transistor amplifier. This transistor is capacitively coupled to the input of the 567 tone decoder. Whenever the 567 detects a frequency within its bandpass, it drives its output high, lighting an LED.

You can expand this circuit by adding additional tone decoders, and using a switch to change the modulated tone's frequency. This allows you to have multiple functions from the remote control unit.

Because of the response characteristics of the GP1U52X, the modulated tone must be between 100 Hz and 1000 Hz, and tones must be at least 150Hz apart for good detection.

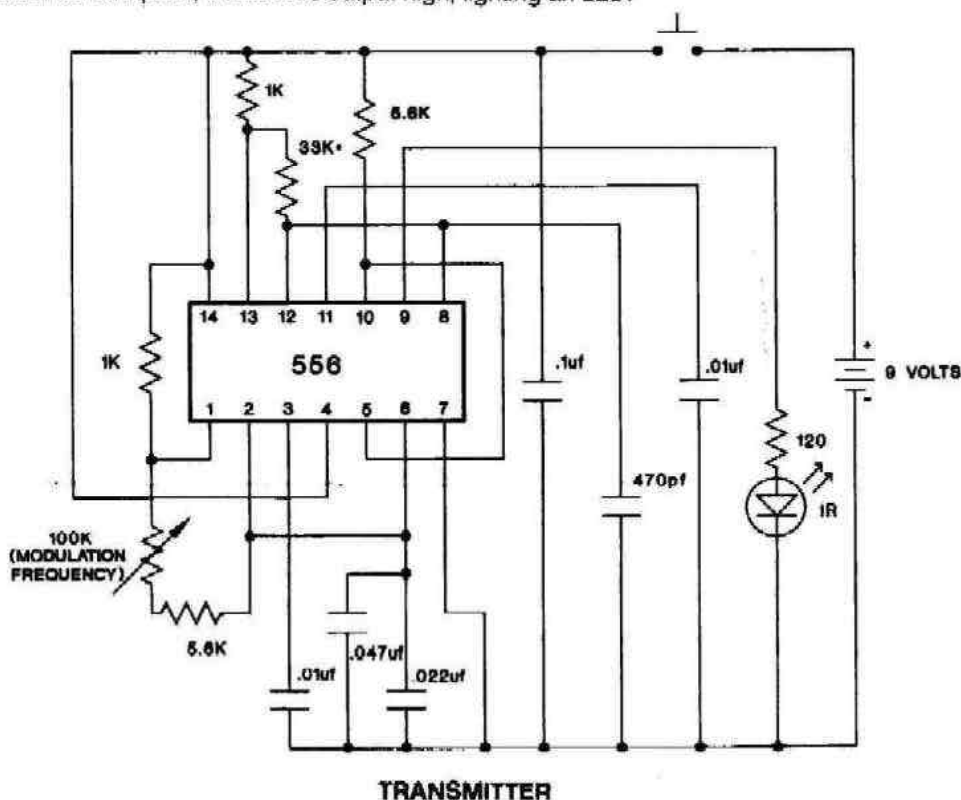

\*Ground Pin 6 and adjust for 40 kHz  $\pm$  2 kHz from Pin 9 with parallel/series resistance.

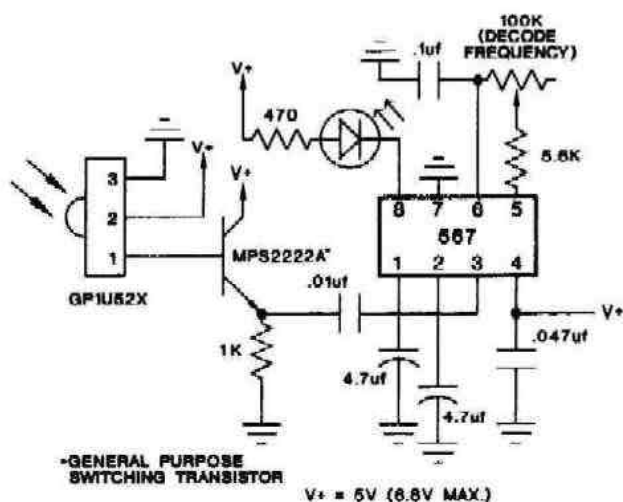

GENERAL PURPOSE SWITCHING TRANSISTOR

V+ = 5V (6.8V MAX.)