

PIN CONFIGURATION (Top View)

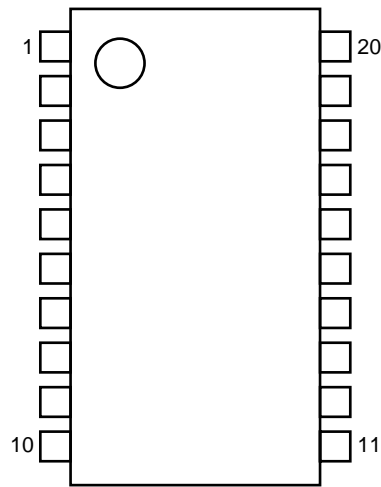

- 1. UHF OSC Collector (Tr. 1)
- 2. UHF OSC Base (Tr. 2)
- 3. UHF OSC Base (Tr. 1)
- 4. UHF OSC Collector (Tr. 2)
- 5. UB
- 6. OSC OUTPUT
- 7. GND
- 8. VHF OSC Base (Tr. 1)
- 9. VHF OSC Base (Tr. 2)
- 10. VHF OSC Collector (Tr. 1)
- 11. REG
- 12. IF OUTPUT
- 13. V_{CC}
- 14. MIX OUTPUT
- 15. MIX OUTPUT
- 16. VHF RF INPUT
- 17. VHF RF INPUT
- 18. GND
- 19. UHF RF INPUT
- 20. UHF RF INPUT

INTERNAL BLOCK DIAGRAM

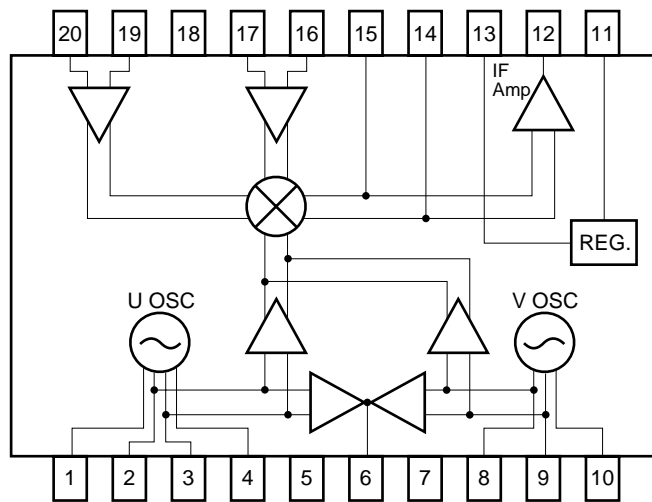

PIN EXPLANATION

| Pin No. | Symbol | Pin Voltage TYP. above: VHF mode below: UHF mode | Function and Explanation | Equivalent Circuit |
|---------|------------------------------|--|---|---------------------------|
| 1 | UOSC collector (Tr. 1) | 6.90 | Collector pin of UHF oscillator. Assemble LC resonator with 2 pin through capacitor ≈ 1 pF to oscillate with active feedback loop. | |
| | | 6.25 | | |
| 2 | UOSC base (Tr.2) | 6.00 | Base pin of UHF oscillator with balance amplifier. Connected to LC resonator through feedback capacitor ≈ 300 pF. | |
| | | 3.90 | | |
| 3 | UOSC base (Tr. 1) | 6.00 | Base pin of UHF oscillator with balance amplifier. Connected to LC resonator through feedback capacitor ≈ 300 pF. | |
| | | 3.90 | | |
| 4 | UOSC collector (Tr. 2) | 6.90 | Collector pin of UHF oscillator with balance amplifier. Assemble LC resonator with 3 pin through capacitor ≈ 1 pF to oscillate with active feedback loop. Double balanced oscillator with transistor 1 and transistor 2. | |
| | | 6.25 | | |
| 5 | UB | — | Switching pin for VHF or UHF operation. VHF operation = open UHF operation = 9.0 V | |
| | | 9.0 | | |
| 6 | OSC output | 5.85 | UHF and VHF oscillator output pin. In case of F/S tuner application, connected PLL synthesizer IC's input pin. Grounded through 1.5 kΩ resistor. | <p>* External element</p> |
| | | 5.85 | | |
| 7 | GND | 0.0 | GND pin of VHF and UHF oscillator. | |
| | | 0.0 | | |
| 8 | VOSC base (Tr. 1) | 3.50 | Base pin of VHF oscillator. Grounded through capacitor ≈ 10 pF. | |
| | | 5.90 | | |
| 9 | VOSC base (Tr. 2) | 3.50 | Base pin of VHF oscillator. Assemble LC resonator with 10 pin to oscillate with active feedback loop. | |
| | | 5.90 | | |
| 10 | VOSC collector (Tr. 1) | 6.20 | Collector pin of VHF oscillator. Connected to LC resonator through feedback capacitor ≈ 3 pF. | |
| | | 6.90 | | |

| Pin No. | Symbol | Pin Voltage TYP. above: VHF mode below: UHF mode | Function and Explanation | Equivalent Circuit |
|---------|--------------------|--|--|--------------------|
| 11 | REG | 6.90 6.90 | Monitor pin of regulator output voltage. | |
| 12 | IF output | 2.80 2.80 | IF output pin of VHF-UHF band functions. | |
| 13 | Vcc | 9.0 9.0 | Power supply pin for VHF-UHF band functions. | |
| 14 | MIX output1 | 7.10 7.05 | VHF and UHF MIX output pins. These pins should be equipped with tank circuit to adjust intermediate frequency. | |
| 15 | MIX output2 | 7.10 7.05 | | |
| 16 | VRF input (bypass) | 3.10 3.10 | Bypass pin for VHF MIX input. Grounded through capacitor. | |
| 17 | VRF input | 3.10 3.10 | VRF signal input pin from antenna. | |
| 18 | GND | 0.0 0.0 | GND pin of MIX, IF amplifier and regulator. | |
| 19 | URF input (bypass) | 3.10 3.10 | Bypass pin for UHF MIX input. Grounded through capacitor. | |
| 20 | URF input | 3.10 3.10 | URF signal input pin from antenna. | |

ABSOLUTE MAXIMUM RATINGS (T_A = 25 °C unless otherwise specified)

| Parameter | Symbol | Condition | Rating | Unit |
|-------------------------------|------------------|--------------------------|-------------|------|
| Supply Voltage 1 | V _{CC} | | 11.0 | V |
| Supply Voltage 2 | UB | | 11.0 | V |
| Power dissipation | P _D | T _A = 75 °C*1 | 500 | mW |
| Operating Ambient Temperature | T _A | | -40 to +75 | °C |
| Storage temperature | T _{stg} | | -60 to +150 | °C |

*1 Mounted on 50 × 50 × 1.6 mm double copper epoxy glass board.

RECOMMENDED OPERATING RANGE

| Parameter | Symbol | MIN. | TYP. | MAX. | Unit |
|-------------------------------|-----------------|------|------|------|------|
| Supply voltage 1 | V _{CC} | 8.0 | 9.0 | 10.0 | V |
| Supply voltage 2 | UB | 8.0 | 9.0 | 10.0 | V |
| Operating Ambient Temperature | T _A | -20 | +25 | +75 | °C |

ELECTRICAL CHARACTERISTICS (T_A = 25 °C, V_{CC} = 9 V, f_{IF} = 45 MHz)

| Parameter | Symbol | Test Conditions | MIN. | TYP. | MAX. | Unit |
|------------------------|----------------------|---|------|------|------|------|
| Circuit Current 1 | I _{CC1} | @VHF, no input signal *1, 2 | 31 | 38 | 45 | mA |
| Circuit Current 2 | I _{CC2} | @UHF, no input signal *1, 2 | 31 | 38 | 45 | mA |
| Conversion Gain 1 | CG1 | f _{RF} = 55 MHz, P _{RF} = -30 dBm P _{OSC} = -10 dBm *3 | 18.5 | 22.0 | 25.5 | dB |
| Conversion Gain 2 | CG2 | f _{RF} = 200 MHz, P _{RF} = -30 dBm P _{OSC} = -10 dBm *3 | 18.5 | 22.0 | 25.5 | dB |
| Conversion Gain 3 | CG3 | f _{RF} = 470 MHz, P _{RF} = -30 dBm P _{OSC} = -10 dBm *3 | 18.5 | 22.0 | 25.5 | dB |
| Conversion Gain 4 | CG4 | f _{RF} = 470 MHz, P _{RF} = -30 dBm P _{OSC} = -10 dBm *3 | 24.5 | 28.0 | 31.5 | dB |
| Conversion Gain 5 | CG5 | f _{RF} = 890 MHz, P _{RF} = -30 dBm P _{OSC} = -10 dBm *3 | 24.5 | 28.0 | 31.5 | dB |
| Noise Figure 1 | NF1 | f _{RF} = 55 MHz, P _{OSC} = -10 dBm *4 | — | 11.0 | 14.0 | dB |
| Noise Figure 2 | NF2 | f _{RF} = 200 MHz, P _{OSC} = -10 dBm *4 | — | 11.0 | 14.0 | dB |
| Noise Figure 3 | NF3 | f _{RF} = 470 MHz, P _{OSC} = -10 dBm *4 | — | 11.0 | 14.0 | dB |
| Noise Figure 4 | NF4 | f _{RF} = 470 MHz, P _{OSC} = 0 dBm *4 | — | 9.5 | 12.5 | dB |
| Noise Figure 5 | NF5 | f _{RF} = 890 MHz, P _{OSC} = 0 dBm *4 | — | 10.0 | 13.0 | dB |
| Maximum Output Power 1 | P _{O(sat)1} | f _{RF} = 55 MHz, P _{RF} = 0 dBm P _{OSC} = -10 dBm *3 | 7.0 | 10.0 | — | dBm |
| Maximum Output Power 2 | P _{O(sat)2} | f _{RF} = 200 MHz, P _{RF} = 0 dBm P _{OSC} = -10 dBm *3 | 7.0 | 10.0 | — | dBm |
| Maximum Output Power 3 | P _{O(sat)3} | f _{RF} = 470 MHz, P _{RF} = 0 dBm P _{OSC} = -10 dBm *3 | 7.0 | 10.0 | — | dBm |
| Maximum Output Power 4 | P _{O(sat)4} | f _{RF} = 470 MHz, P _{RF} = 0 dBm P _{OSC} = -10 dBm *3 | 7.0 | 10.0 | — | dBm |
| Maximum Output Power 5 | P _{O(sat)5} | f _{RF} = 890 MHz, P _{RF} = 0 dBm P _{OSC} = -10 dBm *3 | 7.0 | 10.0 | — | dBm |

- *1 no resistance of OSC output
- *2 By measurement circuit 1
- *3 By measurement circuit 2
- *4 By measurement circuit 3

STANDARD CHARACTERISTICS (Reference Values) (T_A = 25 °C, V_{CC} = 9 V)

| Parameter | Symbol | Test Conditions | Value for Reference | Unit |
|-----------------------------------|--------|---|---------------------|------|
| 1 % cross-modulation distortion 1 | CM1 | f _{des} = 55 MHz, f _{undes} = f _{des} + 6 MHz, P _{des} = -30 dBm, f _{iF} = 45 MHz, P _{osc} = -10 dBm, AM 100 kHz, 30 % modulation, DES/CM = 46 dBc *1 | 100 | dBμ |
| 1 % cross-modulation distortion 2 | CM2 | f _{des} = 200 MHz, f _{undes} = f _{des} + 6 MHz, P _{des} = -30 dBm, f _{iF} = 45 MHz, P _{osc} = -10 dBm, AM 100 kHz, 30 % modulation, DES/CM = 46 dBc *1 | 100 | dBμ |
| 1 % cross-modulation distortion 3 | CM3 | f _{des} = 470 MHz, f _{undes} = f _{des} + 6 MHz, P _{des} = -30 dBm, f _{iF} = 45 MHz, P _{osc} = -10 dBm, AM 100 kHz, 30 % modulation, DES/CM = 46 dBc *1 | 96 | dBμ |
| 1 % cross-modulation distortion 4 | CM4 | f _{des} = 470 MHz, f _{undes} = f _{des} + 6 MHz, P _{des} = -30 dBm, f _{iF} = 45 MHz, P _{osc} = -10 dBm, AM 100 kHz, 30 % modulation, DES/CM = 46 dBc *1 | 94 | dBμ |
| 1 % cross-modulation distortion 5 | CM5 | f _{des} = 890 MHz, f _{undes} = f _{des} + 6 MHz, P _{des} = -30 dBm, f _{iF} = 45 MHz, P _{osc} = -10 dBm, AM 100 kHz, 30 % modulation, DES/CM = 46 dBc *1 | 92 | dBμ |

*1 By measurement circuit 4

TYPICAL CHARACTERISTICS

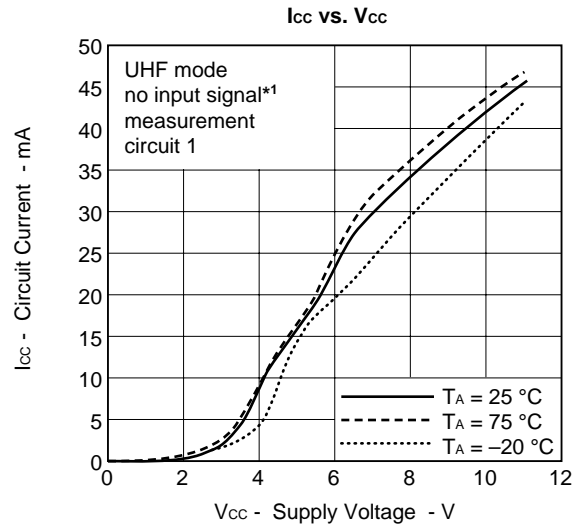
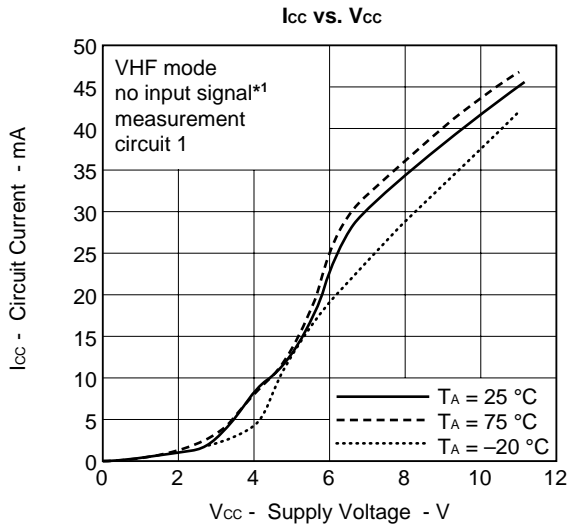

*1 External resistor is removed.

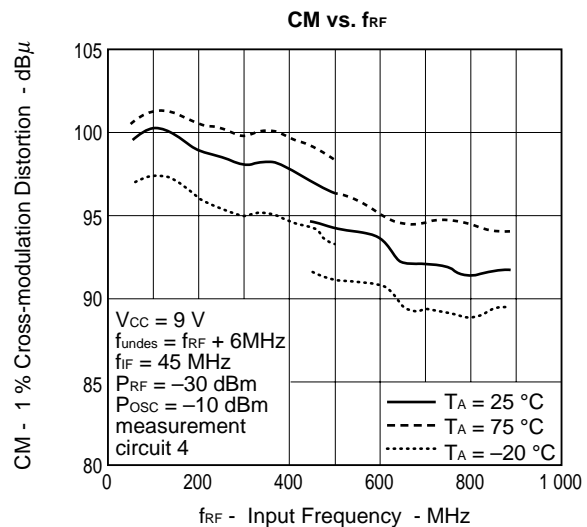
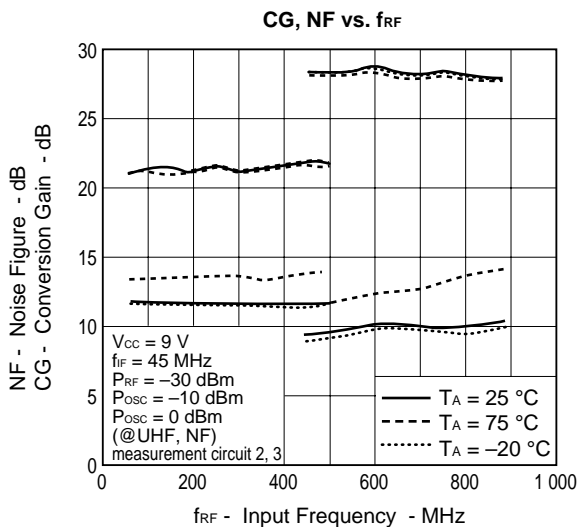
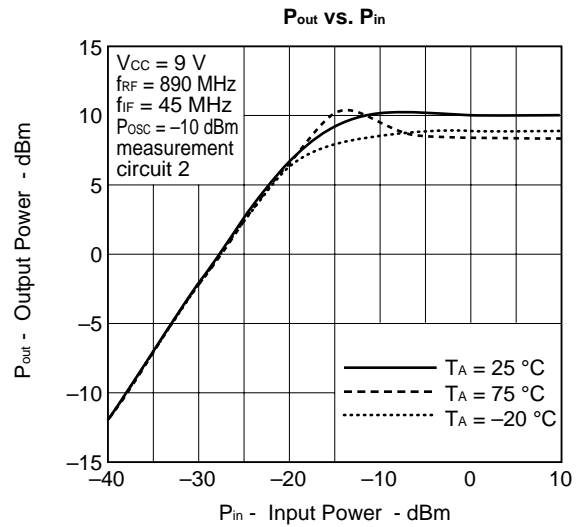
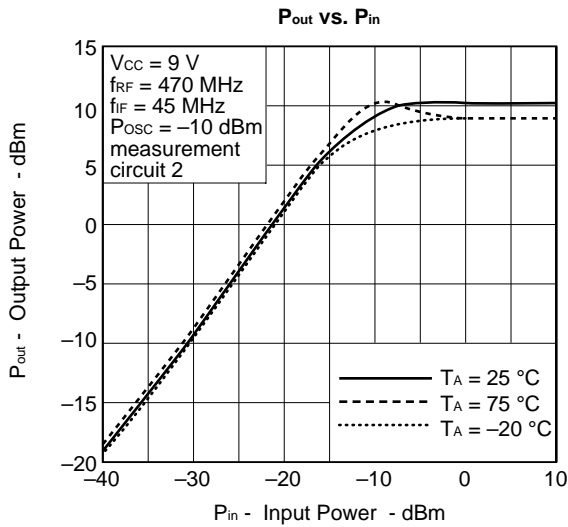

STANDARD CHARACTERISTICS (by application circuit example)

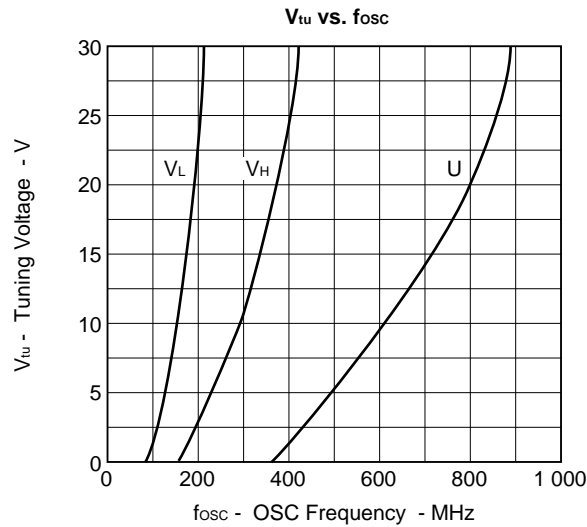
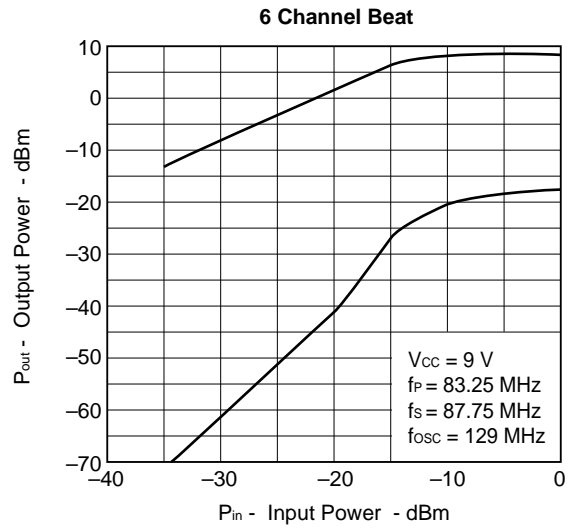
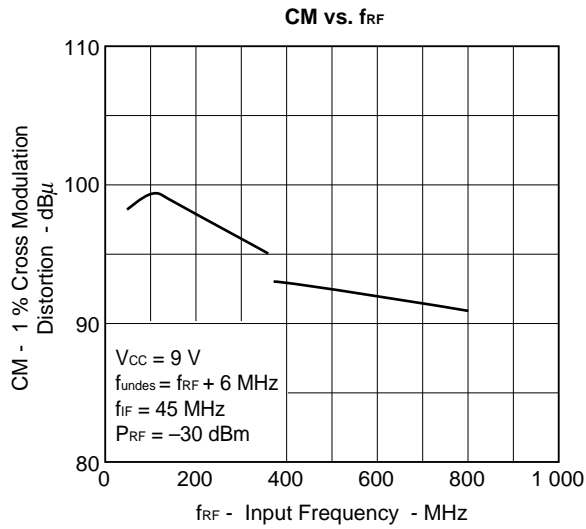
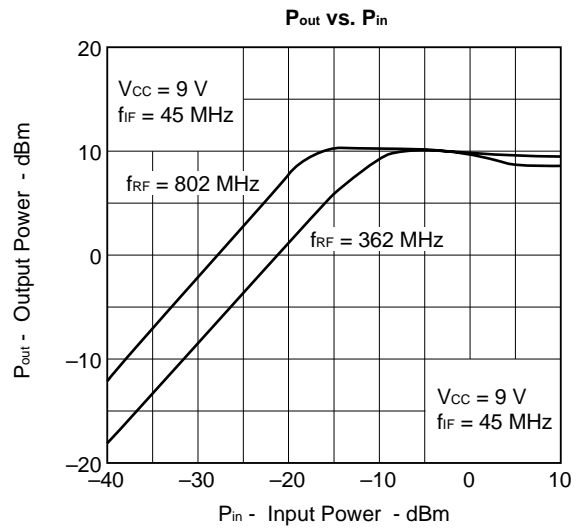
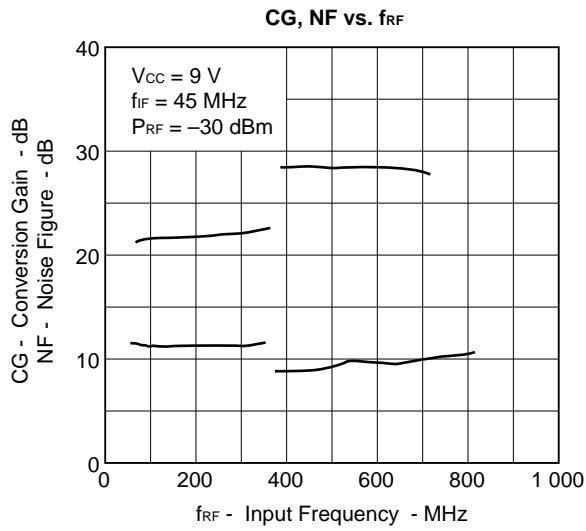

INPUT IMPEDANCE (by measurement circuit 5)

<VRF INPUT: 17 PIN>

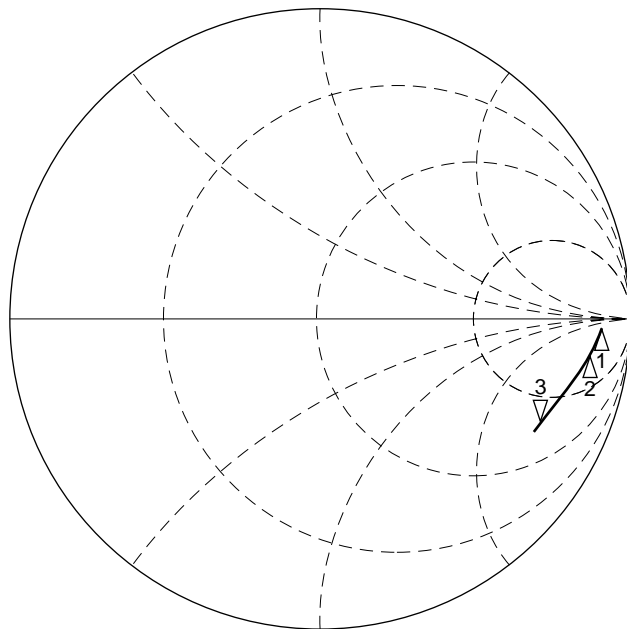

- ▽ 1 45 MHz
874.28Ω -221.97Ω
- ▽ 2 200 MHz
375.14Ω -369.39Ω
- ▽ 3 470 MHz
98.023Ω -170.73Ω

START 0.045000000 GHz
STOP 0.500000000 GHz

<URF INPUT: 20 PIN>

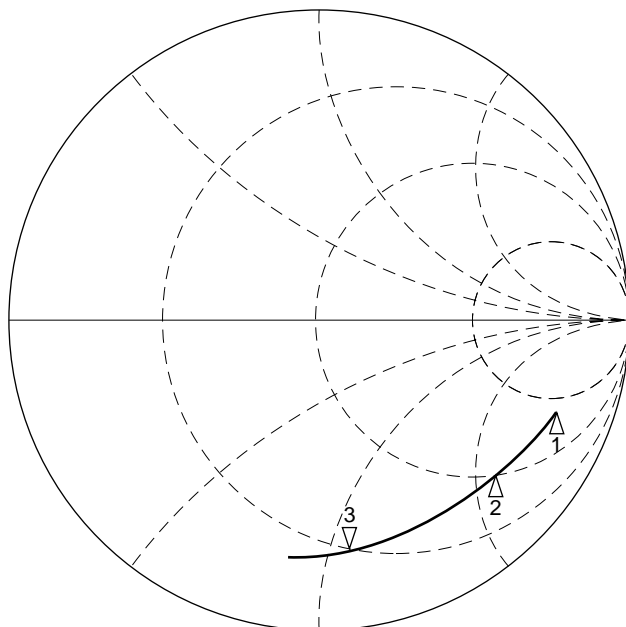

- ▽ 1 400 MHz
117.56Ω -204.60Ω
- ▽ 2 600 MHz
50.523Ω -116.67Ω
- ▽ 3 890 MHz
16.645Ω -54.867Ω

START 0.400000000 GHz
STOP 1.000000000 GHz

OUTPUT IMPEDANCE (by measurement circuit 5)

<IF OUTPUT: 12 PIN>

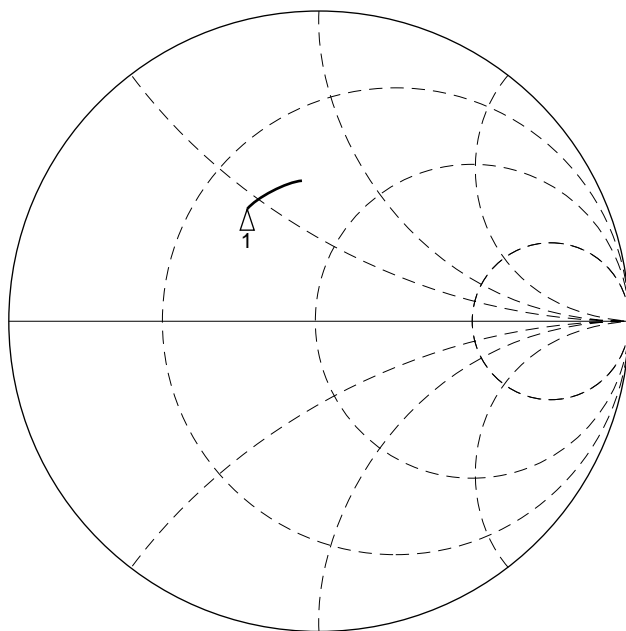

▽ 1 45 MHz
53.869Ω 53.543Ω

START 0.045000000 GHz
STOP 0.065000000 GHz

MEASUREMENT CIRCUIT 1

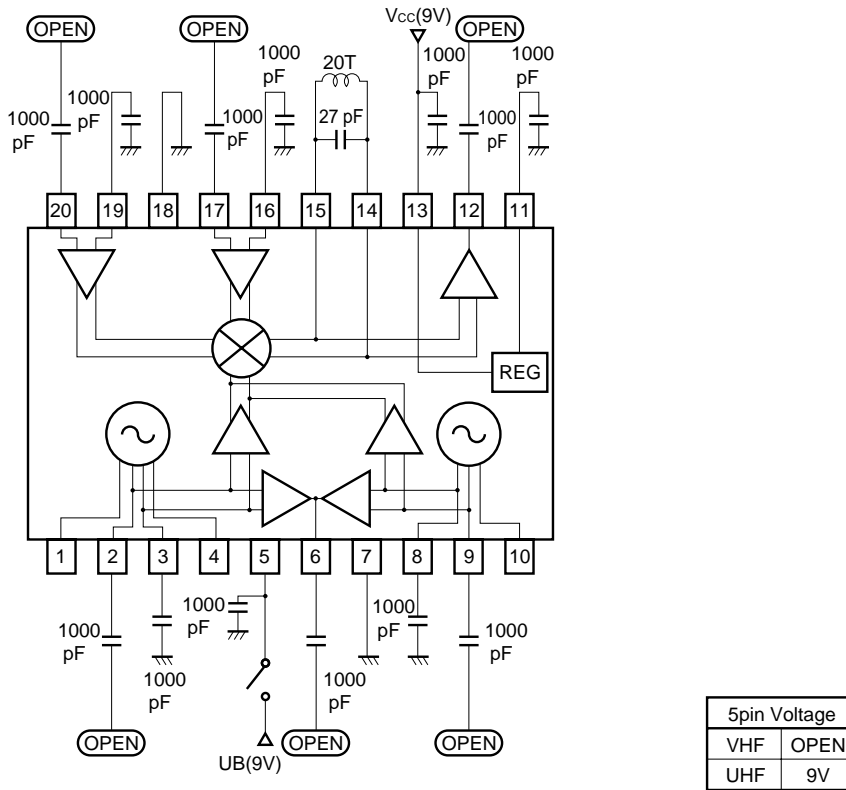

MEASUREMENT CIRCUIT 2

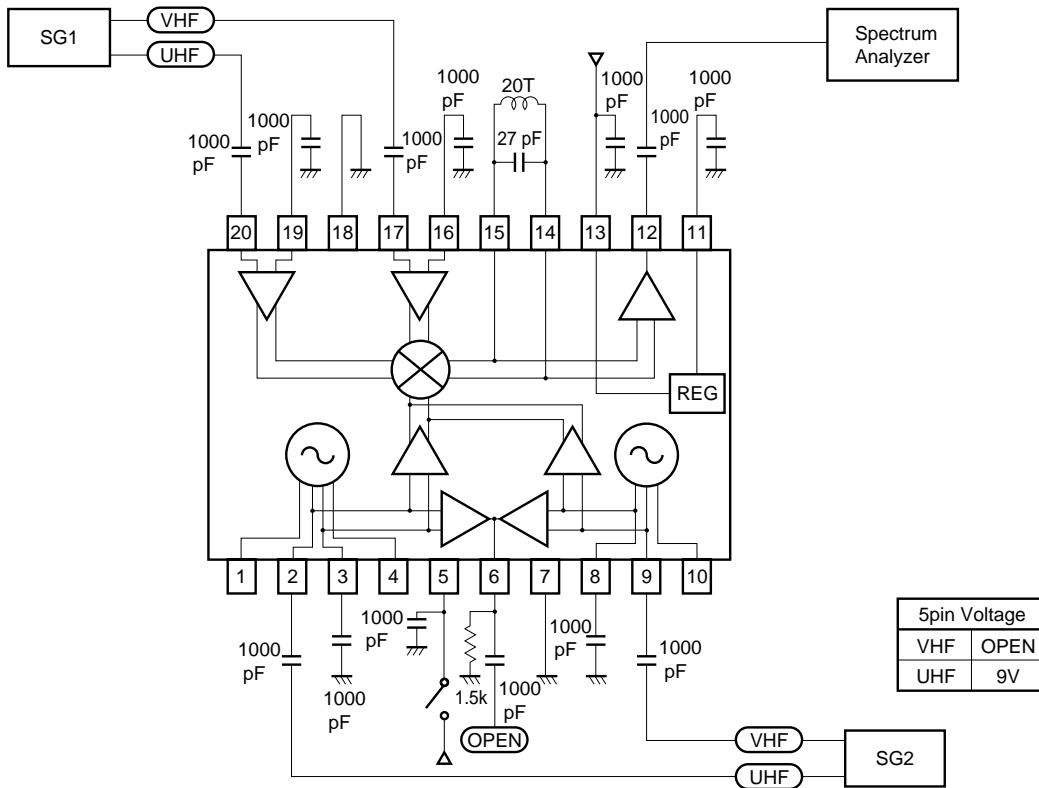

MEASUREMENT CIRCUIT 3

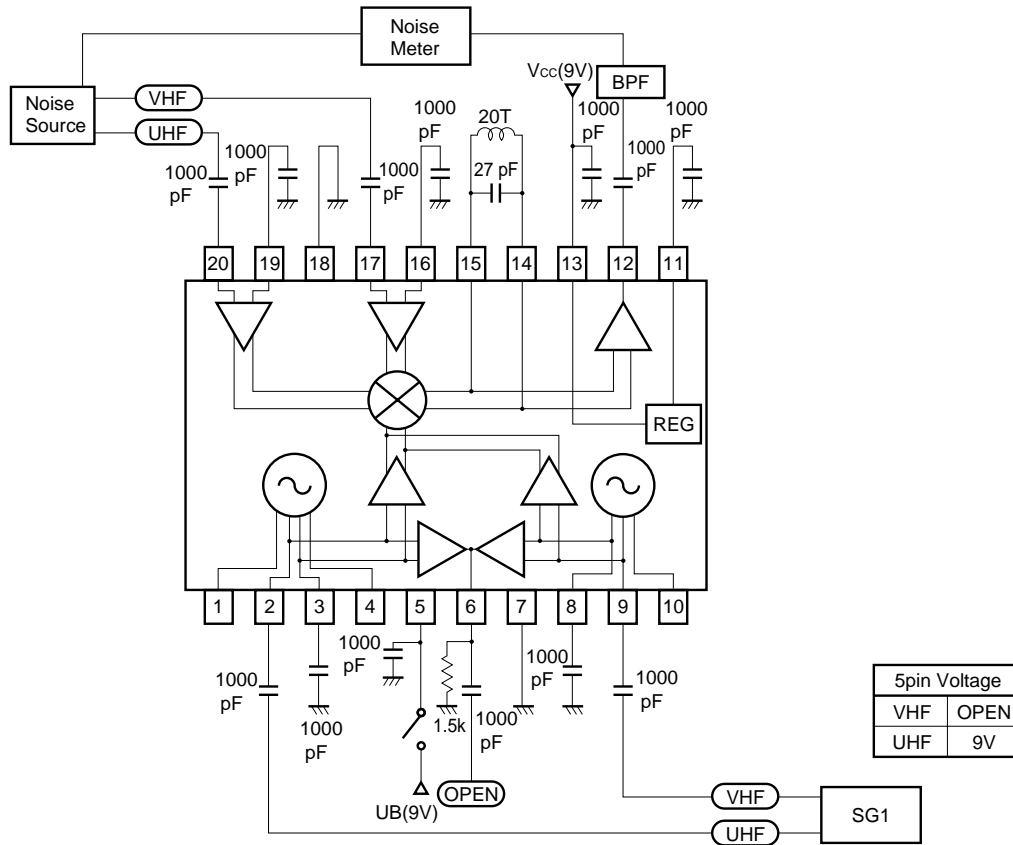

MEASUREMENT CIRCUIT 4

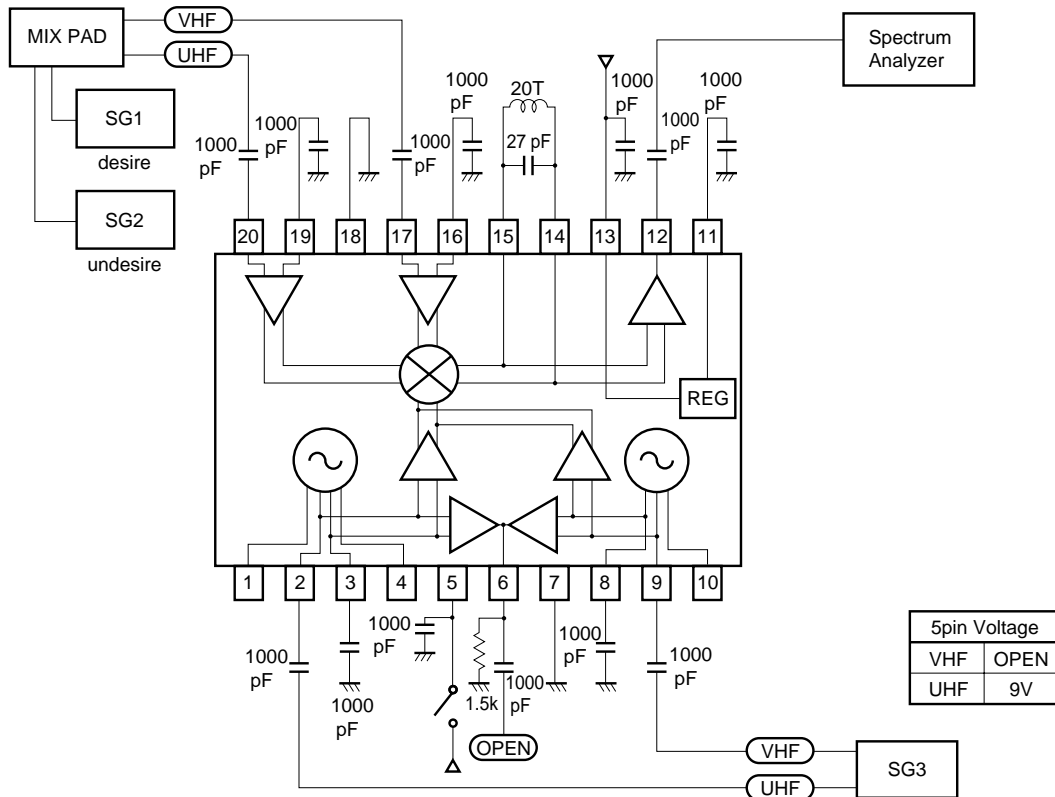

MEASUREMENT CIRCUIT 5

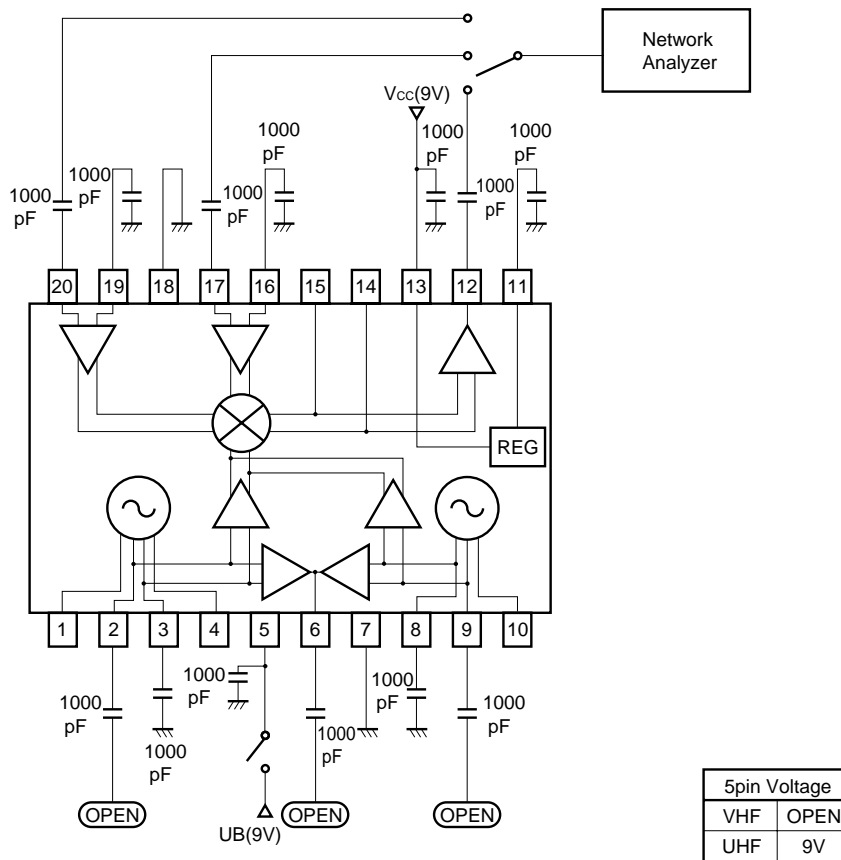

Application Circuit Example

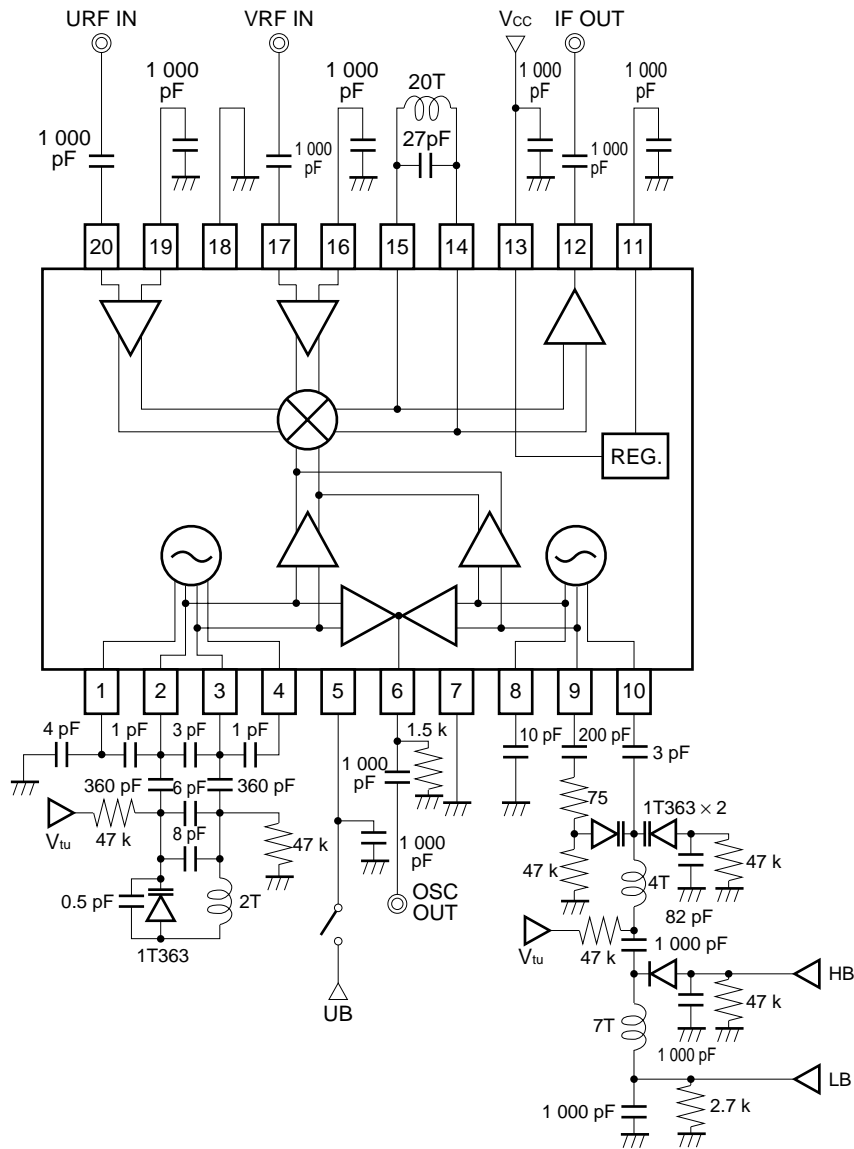

The application circuits and their parameters are for reference only and are not intended for use in actual design-ins.

ILLUSTRATION OF THE EVALUATION BOARD FOR APPLICATION CIRCUIT EXAMPLE (Surface)

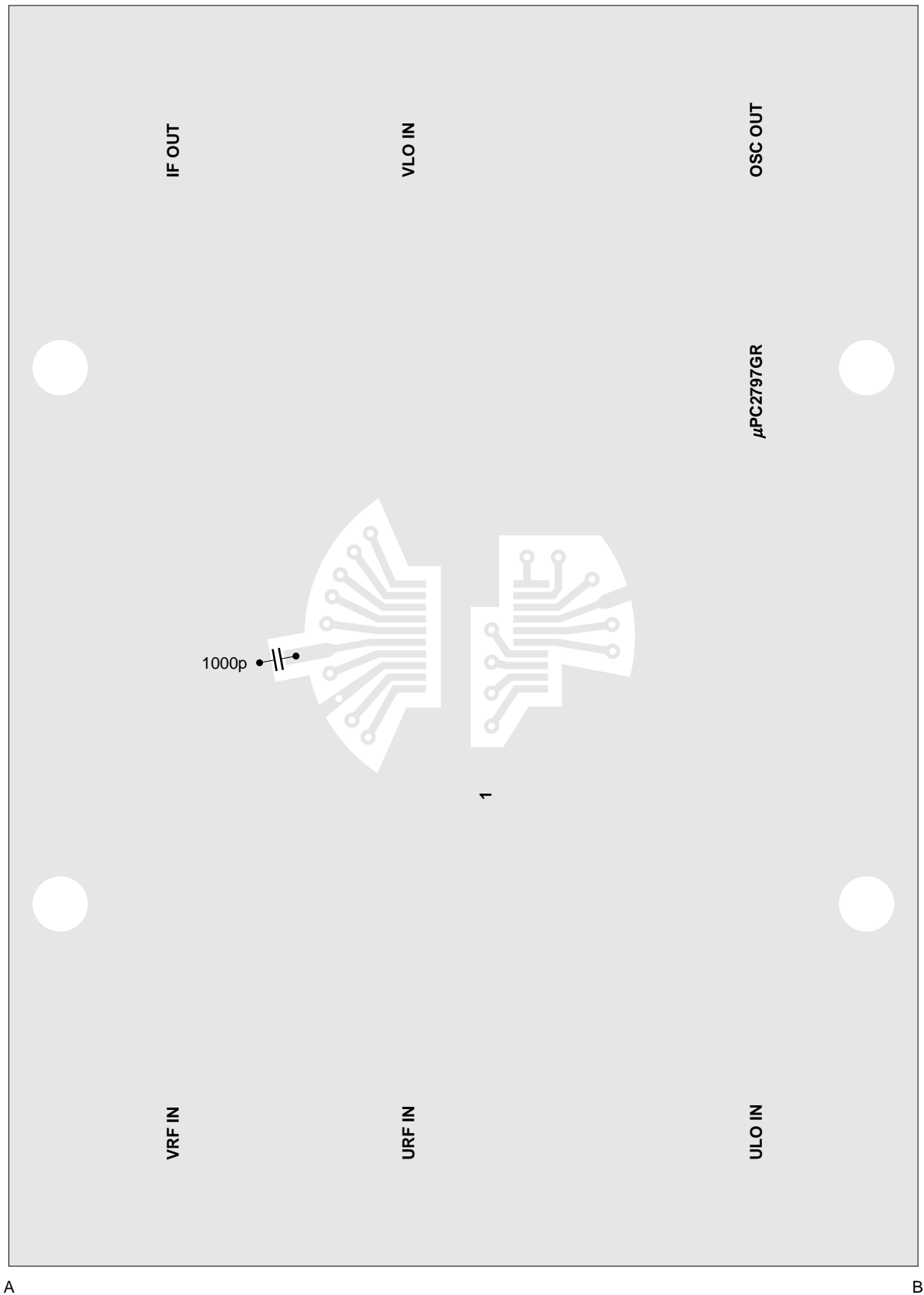
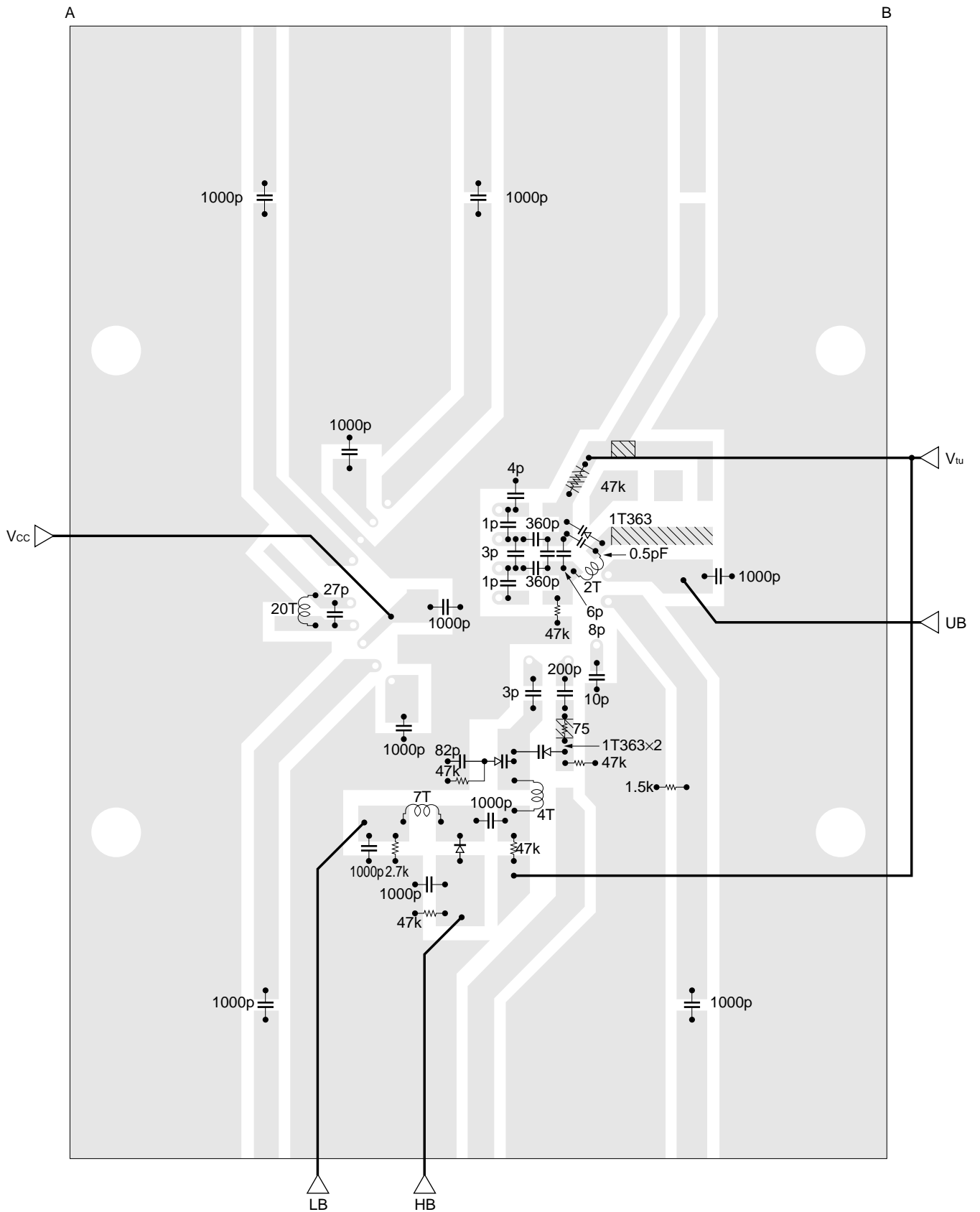



ILLUSTRATION OF THE EVALUATION BOARD FOR APPLICATION CIRCUIT EXAMPLE (Back side)



 represents cutout

PACKAGE DIMENSIONS

★ 20 PIN PLASTIC SSOP (225 mil) (UNIT: mm)

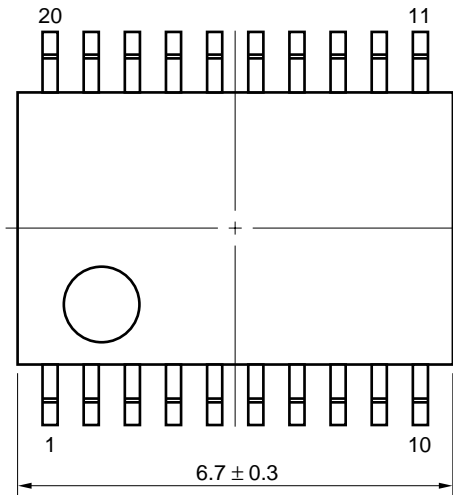

detail of lead end

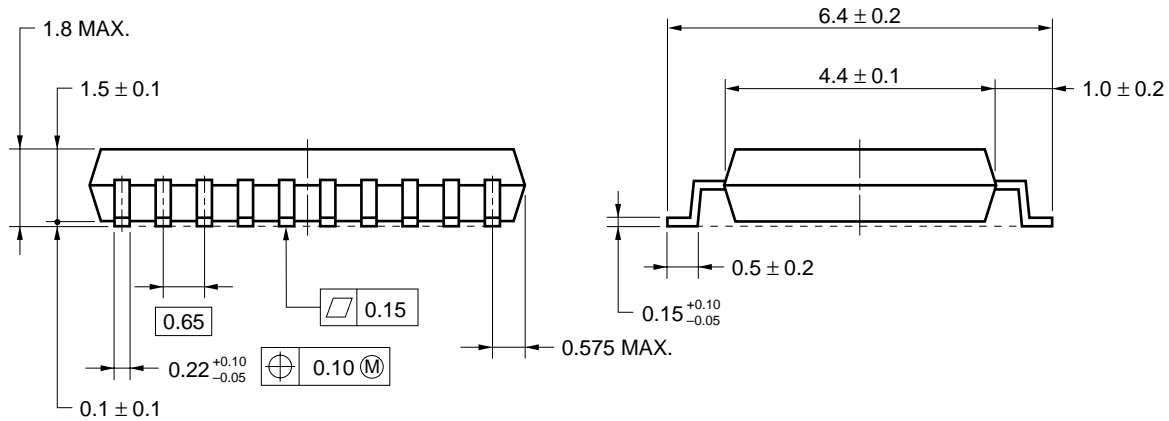
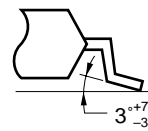

NOTE Each lead centerline is located within 0.10 mm of its true position (T.P.) at maximum material condition.

NOTE ON CORRECT USE

- (1) Observe precautions for handling because of electro-static sensitive devices.
- (2) Form a ground pattern as widely as possible to minimize ground impedance (to prevent undesires oscillation).
- (3) Keep the track length of the ground pins as short as possible.
- (4) A low pass filter must be attached to Vcc line.
- (5) A matching circuit must be externally attached to output port.

RECOMMENDED SOLDERING CONDITIONS

The following conditions (see table below) must be met when soldering this product.

Please consult with our sales officers in case other soldering process is used or in case soldering is done under different conditions.

For details of recommended soldering conditions for surface mounting, refer to information document SEMICONDUCTOR DEVICE MOUNTING TECHNOLOGY MANUAL (C10535E).

μPC2797GR

| Soldering Process | Soldering Conditions | Symbol |
|------------------------|---|-----------|
| Infrared ray reflow | Peak package's surface temperature: 235 °C or below, Reflow time: 30 seconds or below (210 °C or higher), Number of reflow process: 3, Exposure limit*1: None | IR35-00-3 |
| VPS | Peak package's surface temperature: 215 °C or below, Reflow time: 40 seconds or below (200 °C or higher), Number of reflow process: 3, Exposure limit*1: None | VP15-00-3 |
| Partial heating method | Terminal temperature: 300 °C or below, Flow time: 3 seconds or below, Exposure limit*1: None | |

*1 Exposure limit before soldering after dry-pack package is opened.
Storage conditions: 25 °C and relative humidity at 65 % or less.

Caution Do not apply more than single process at once, except for “Partial heating method”.

NESAT (NEC Silicon Advanced Technology) is a trademark of NEC Corporation.

- **The information in this document is subject to change without notice. Before using this document, please confirm that this is the latest version.**
 - No part of this document may be copied or reproduced in any form or by any means without the prior written consent of NEC Corporation. NEC Corporation assumes no responsibility for any errors which may appear in this document.
 - NEC Corporation does not assume any liability for infringement of patents, copyrights or other intellectual property rights of third parties by or arising from use of a device described herein or any other liability arising from use of such device. No license, either express, implied or otherwise, is granted under any patents, copyrights or other intellectual property rights of NEC Corporation or others.
 - Descriptions of circuits, software, and other related information in this document are provided for illustrative purposes in semiconductor product operation and application examples. The incorporation of these circuits, software, and information in the design of the customer's equipment shall be done under the full responsibility of the customer. NEC Corporation assumes no responsibility for any losses incurred by the customer or third parties arising from the use of these circuits, software, and information.
 - While NEC Corporation has been making continuous effort to enhance the reliability of its semiconductor devices, the possibility of defects cannot be eliminated entirely. To minimize risks of damage or injury to persons or property arising from a defect in an NEC semiconductor device, customers must incorporate sufficient safety measures in its design, such as redundancy, fire-containment, and anti-failure features.
 - NEC devices are classified into the following three quality grades:
"Standard", "Special", and "Specific". The Specific quality grade applies only to devices developed based on a customer designated "quality assurance program" for a specific application. The recommended applications of a device depend on its quality grade, as indicated below. Customers must check the quality grade of each device before using it in a particular application.
 - Standard: Computers, office equipment, communications equipment, test and measurement equipment, audio and visual equipment, home electronic appliances, machine tools, personal electronic equipment and industrial robots
 - Special: Transportation equipment (automobiles, trains, ships, etc.), traffic control systems, anti-disaster systems, anti-crime systems, safety equipment and medical equipment (not specifically designed for life support)
 - Specific: Aircraft, aerospace equipment, submersible repeaters, nuclear reactor control systems, life support systems or medical equipment for life support, etc.
- The quality grade of NEC devices is "Standard" unless otherwise specified in NEC's Data Sheets or Data Books. If customers intend to use NEC devices for applications other than those specified for Standard quality grade, they should contact an NEC sales representative in advance.