

VERTICAL DRIVER FOR CCD SENSOR

The μ PD16510 is a vertical driver dedicated for CCD area image sensors that incorporates a level conversion circuit and a three-level output function. It contains a CCD vertical register driver (4 channels) and a VOD shutter driver (1 channel).

The μ PD16510, which uses the CMOS process, provides optimum transmission delay and output ON resistance characteristics for the vertical drive of CCD sensors. It can be used for low-voltage logic (logic power-supply voltage: 2.0 to 5.5 V).

FEATURES

- CCD vertical register driver : 4 channels, VOD shutter driver: 1 channel
- Small package : 20-pin plastic shrink SOP (225 mil)
- High breakdown voltage : 33 V MAX.
- Low output ON resistance : 30 Ω TYP.
- Low voltage operation (logic power-supply voltage: 2.0 to 5.5 V)
- Latch-up free
- Pin-compatible with μ PD16506 (CCD driver)

APPLICATIONS

- Camcorders

ORDERING INFORMATION

Part Number	Package
μ PD16510GR-8JG	20-pin plastic shrink SOP (225 mil)

The information in this document is subject to change without notice.

BLOCK DIAGRAM

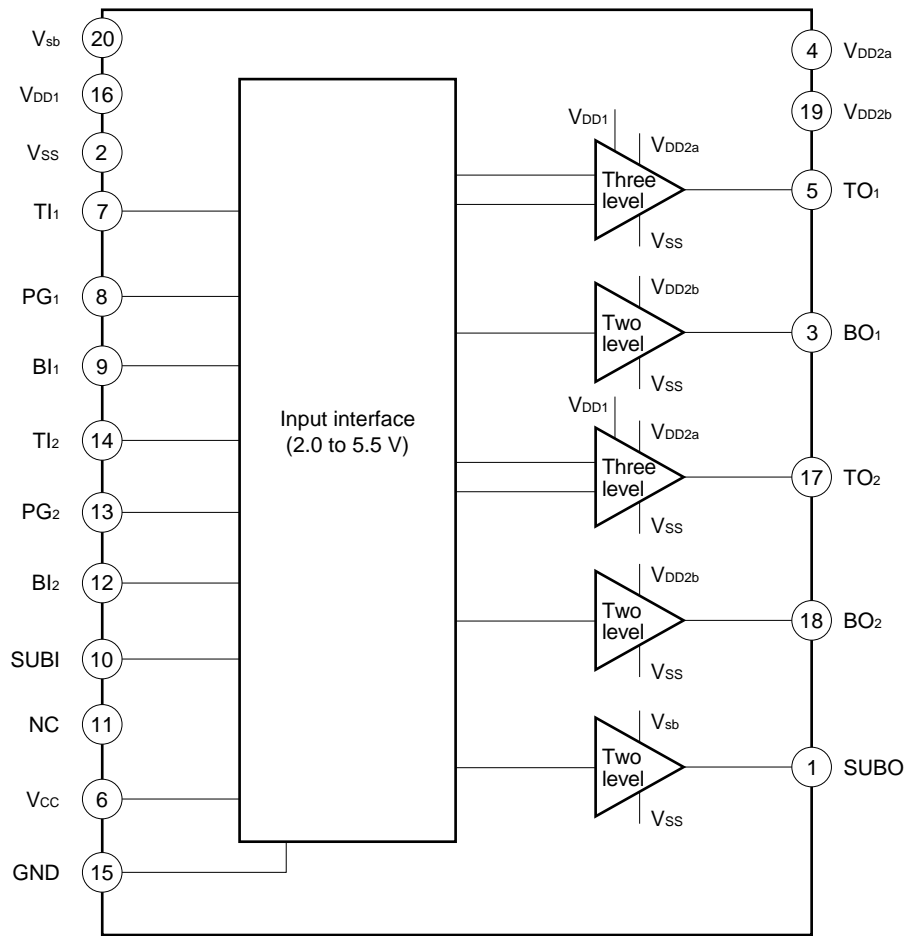

PIN CONFIGURATION

20-pin plastic shrink SOP (225 mil)

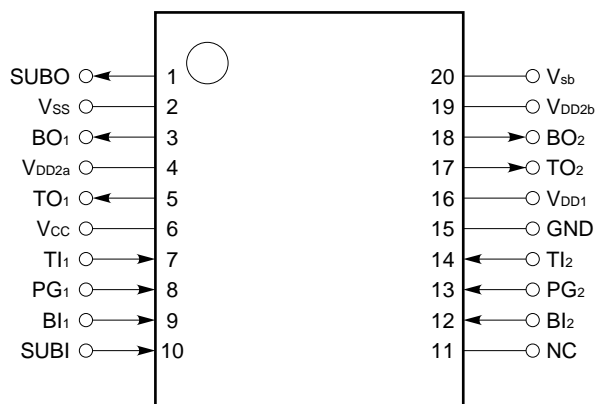

Remark The μPD16510 is pin-compatible with the μPD16506 (CCD driver). However, the VOD shutter drive pulse input polarity switching pin (SSP) of the μPD16506 corresponds to the GND pin in the μPD16510 (pin 15).

PIN FUNCTIONS

No.	Symbol	I/O	Pin Function
1	SUBO	O	VOD shutter drive pulse output
2	V _{SS}	–	V _L power supply
3	BO ₁	O	Two-level pulse output
4	V _{DD2a}	–	V _{Ma} (Three-level driver) power supply
5	TO ₁	O	Three-level pulse output
6	V _{CC}	–	Logic power supply
7	TI ₁	I	Three-level driver input (See Functions table on p. 4)
8	PG ₁	I	
9	BI ₁	I	Two-level driver input (See Functions table on p. 4)
10	SUBI	I	VOD shutter drive pulse input
11	NC	–	Non connect
12	BI ₂	I	Two-level driver input (See Functions table on p. 4)
13	PG ₂	I	Three-level driver input (See Functions table on p. 4)
14	TI ₂	I	
15	GND	–	Ground
16	V _{DD1}	–	V _H power supply
17	TO ₂	O	Three-level pulse output
18	BO ₂	O	Two-level pulse output
19	V _{DD2b}	–	V _{Mb} (Two-level driver) power supply
20	V _{sb}	–	V _{HH} (for SUB drive) power supply

FUNCTIONS

$V_L = V_{SS}$, $V_{Ma} = V_{DD2a}$, $V_{Mb} = V_{DD2b}$, $V_H = V_{DD1}$, $V_{HH} = V_{sb}$

Pin TO₁

Input		Output (TO ₁)
TI ₁	PG ₁	
L	L	V _H
L	H	V _{Ma}
H	L	V _L
H	H	

Pin TO₂

Input		Output (TO ₂)
TI ₂	PG ₂	
L	L	V _H
L	H	V _{Ma}
H	L	V _L
H	H	

Pin BO₁

Input	Output (BO ₁)
BI ₁	
L	V _{Mb}
H	V _L

Pin BO₂

Input	Output (BO ₂)
BI ₂	
L	V _{Mb}
H	V _L

Pin SUBO

Input	Output (SUBO)
SUBI	
L	V _{HH}
H	V _L

Usage Caution

Because the μPD16510 contains a PN junction (diode) between $V_{DD2} \rightarrow V_{DD1}$, if the voltage is $V_{DD2} > V_{DD1}$, an abnormal current will result.

Therefore, apply power in the sequence $V_{DD1} \rightarrow V_{DD2}$, or apply power simultaneously to V_{DD1} and V_{DD2} .

ELECTRICAL SPECIFICATIONS

ABSOLUTE MAXIMUM RATINGS (Unless otherwise specified, $T_A = 25\text{ }^\circ\text{C}$, GND = 0 V)

Parameter	Symbol	Conditions	Rating	Unit
Power supply voltage	V_{CC}		$V_{SS}-0.3$ to $V_{SS}+20.0$	V
Power supply voltage	V_{DD1}		$V_{SS}-0.3$ to $V_{SS}+33.0$	V
Power supply voltage	V_{DD2}		$V_{SS}-0.3$ to $V_{SS}+33.0$	V
Power supply voltage	V_{sb}		$V_{SS}-0.3$ to $V_{SS}+33.0$	V
Input voltage	V_I		$V_{SS}-0.3$ to $V_{CC}+0.3$	V
Operating ambient temperature	T_A		-25 to +85	$^\circ\text{C}$
Storage temperature	T_{stg}		-40 to +125	$^\circ\text{C}$
★ Power dissipation	P_d	$T_A = 85\text{ }^\circ\text{C}$	260	mW

Caution Exposure to Absolute Maximum Rating for extended periods may affect device reliability; exceeding the ratings could cause permanent damage. The parameters apply independently.

RECOMMENDED OPERATING CONDITIONS ($T_A = 25\text{ }^\circ\text{C}$, GND = 0 V)

Parameter	Symbol	Conditions	MIN.	TYP.	MAX.	Unit
Power supply voltage	V_{CC}		2.0		5.5	V
Power supply voltage	V_{DD1}	Note	10.5	15.0	21.0	V
Power supply voltage	$V_{DD1}-V_{SS}$	Note	20.5		31.0	V
Power supply voltage	V_{DD2a}		-1.0		+4.0	V
Power supply voltage	V_{DD2b}		-1.0		+4.0	V
Power supply voltage	V_{SS}	Note	-10.0		-6.0	V
Power supply voltage	$V_{sb}-V_{SS}$				31.0	V
Input voltage, high	V_{IH}		$-0.8 V_{CC}$		V_{CC}	V
Input voltage, low	V_{IL}		0		$0.3 V_{CC}$	V
Operating ambient temperature	T_A		-20		+70	$^\circ\text{C}$

Note Set the values of V_{DD1} and V_{SS} to conform to $V_{DD1}-V_{SS}$ specification value.

ELECTRICAL CHARACTERISTICS

(Unless otherwise specified, $V_{DD1} = +15\text{ V}$, $V_{DD2a} = 0\text{ V}$, $V_{DD2b} = +1.0\text{ V}$, $V_{sb} = +21.5\text{ V}$, $V_{CC} = +2.5\text{ V}$, $V_{SS} = -7.0\text{ V}$, $T_A = 25\text{ }^\circ\text{C}$, $\text{GND} = 0\text{ V}$)

Parameter	Symbol	Conditions	MIN.	TYP.	MAX.	Unit
Output voltage, high	V_H	$I_o = -20\ \mu\text{A}$	$V_{DD1}-0.1$		V_{DD1}	V
Output voltage, middle	V_{Ma}		$V_{DD2a}-0.1$		V_{DD2a}	V
Output voltage, middle	V_{Mb}	$I_o = 20\ \mu\text{A}$	$V_{DD2b}-0.1$		V_{DD2b}	V
Output voltage, low	V_L		$V_{SS}+0.1$		V_{SS}	V
Output voltage, sub high	V_{subH}	$I_o = -20\ \mu\text{A}$	$V_{sb}-0.1$		V_{sb}	V
Output voltage, sub low	V_{subL}	$I_o = 20\ \mu\text{A}$	$V_{SS}+0.1$		V_{SS}	V
Output ON resistance	R_L	$I_o = 10\text{ mA}$		20	30	Ω
Output ON resistance	R_M	$I_o = \pm 10\text{ mA}$		30	45	Ω
Output ON resistance	R_H	$I_o = -10\text{ mA}$		30	40	Ω
Output ON resistance	R_{sub}			30	40	Ω
Transmission delay time 1	T_{D1}	No load, see Figure 2. Timing Chart.			200	ns
Transmission delay time 2	T_{D2}				200	ns
Transmission delay time 3	T_{D3}				200	ns
Rise/Fall time 1	T_{P1}	See Figure 1. Output Load Circuit.			500	ns
Rise/Fall time 2	T_{P2}	See Figure 2. Timing Chart.			500	ns
Rise/Fall time 3	T_{P3}				200	ns
Consumption Current	I_{CC}	See Figure 1. Output Load Circuit.		0.5	1.0	mA
Consumption Current	I_{DD2a}	See Figure 3. Input Waveform.		3.0	5.0	mA
Consumption Current	I_{DD2b}			3.0	5.0	mA
Consumption Current	I_{DD1}			1.5	3.0	mA
Consumption Current	I_{sb}			1.2	1.8	mA

Figure 1. Output Load Circuit

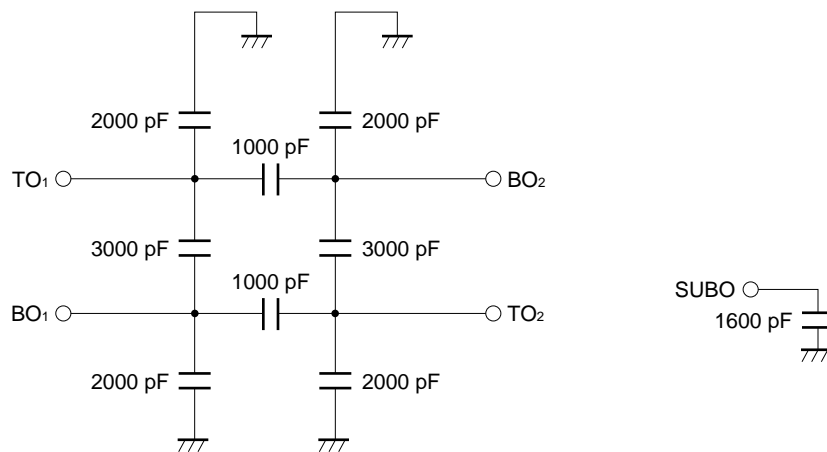

Figure 2. Timing Chart

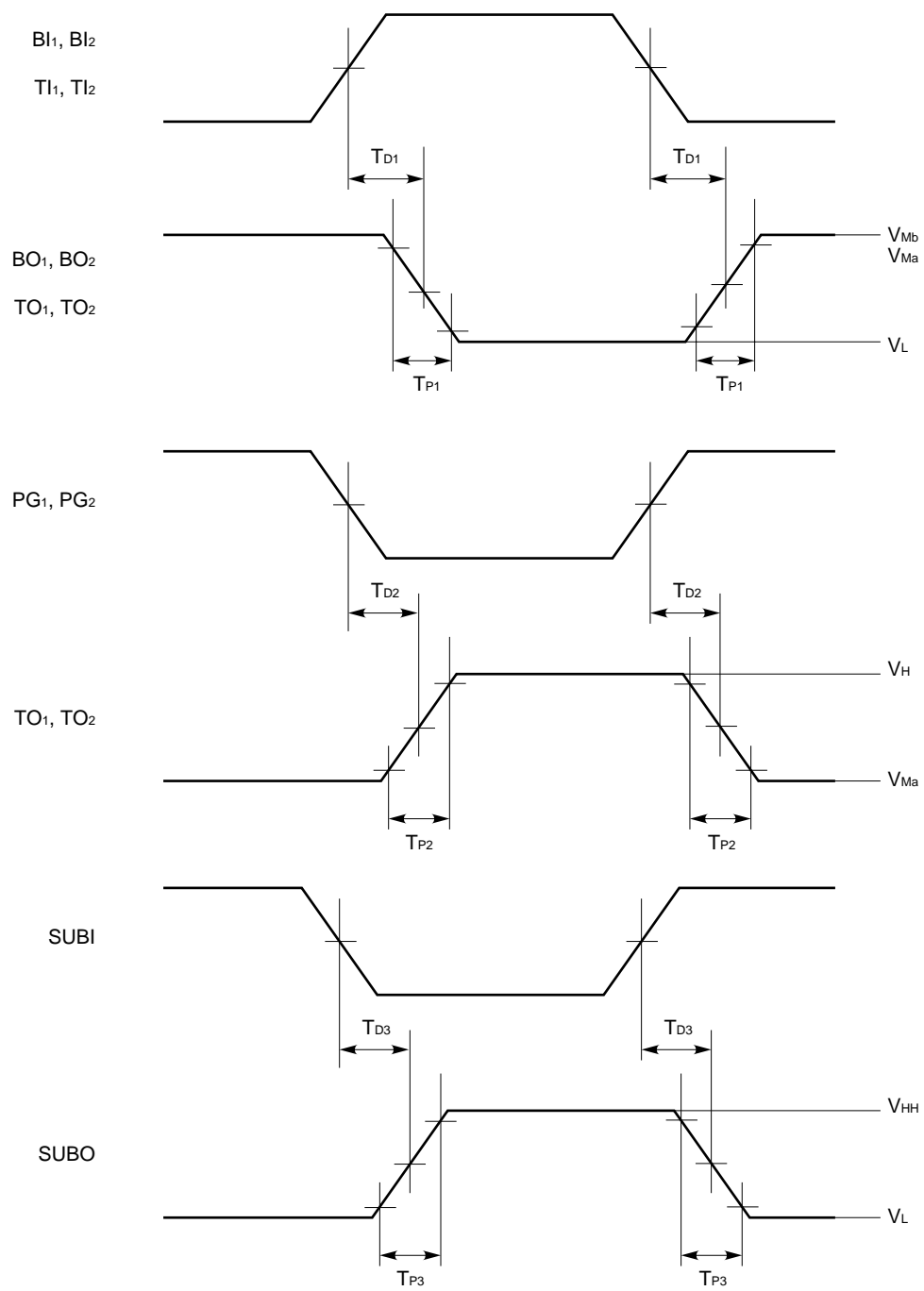
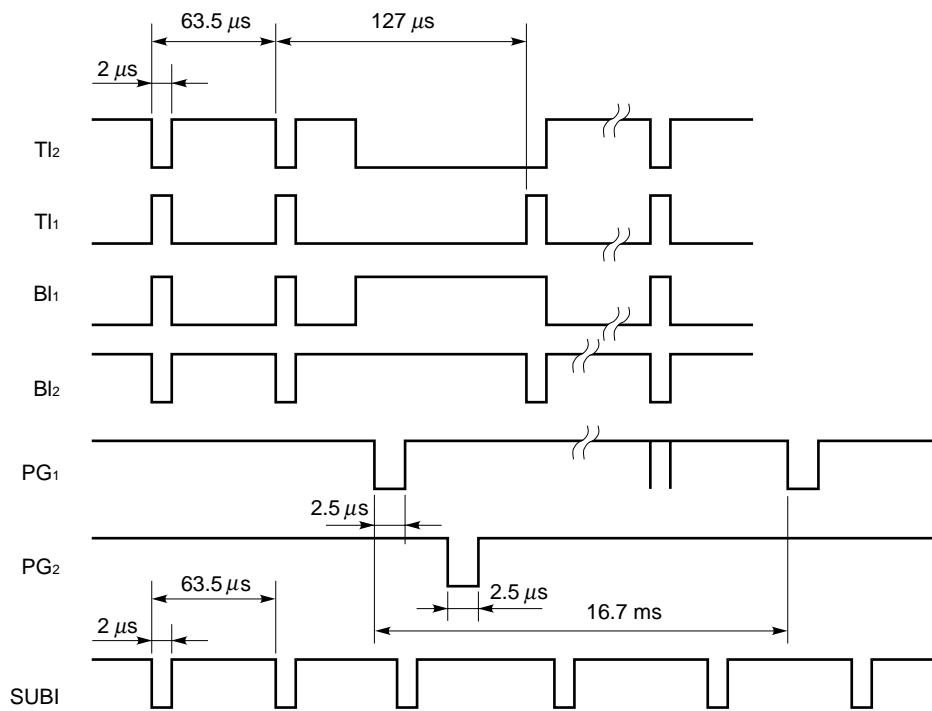
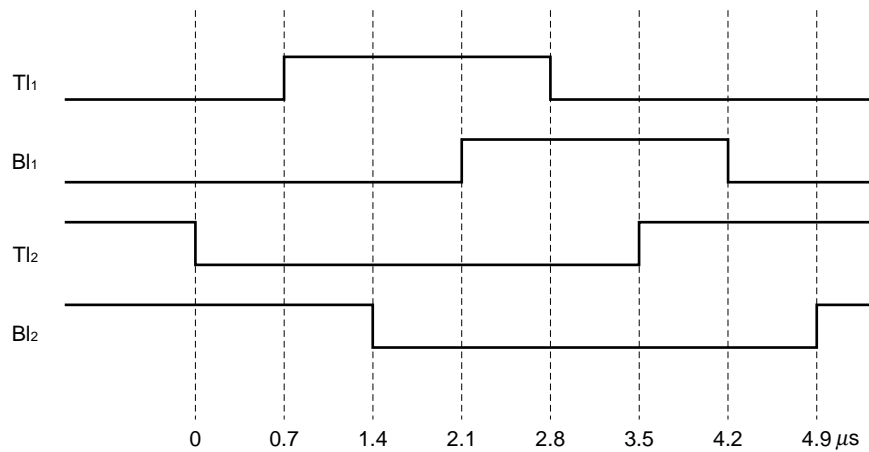

Figure 3. Input Waveform

Input pulse timing diagram



Overlap section enlarged diagram



APPLICATION CIRCUIT EXAMPLE

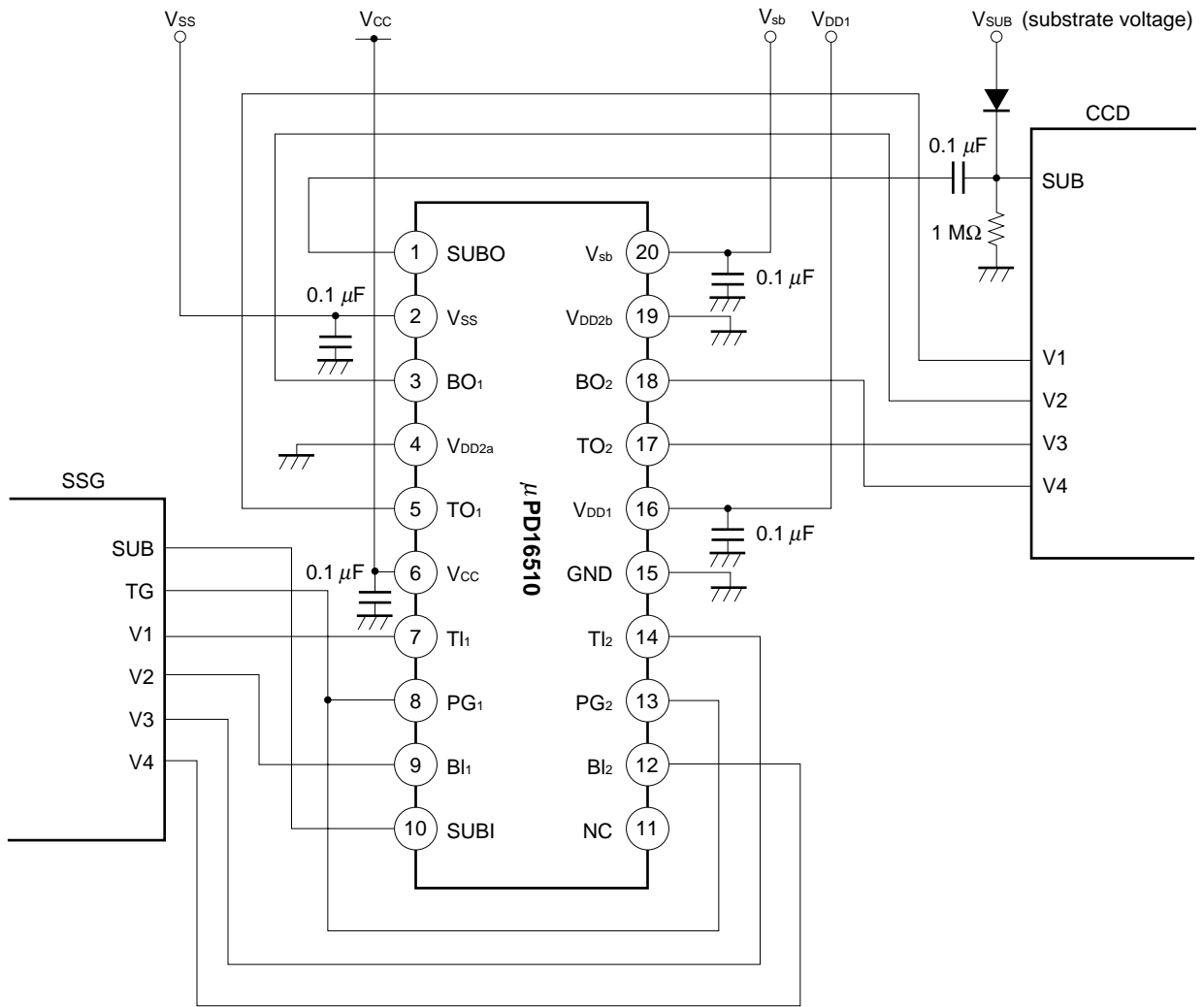

PACKAGE DRAWING

20 PIN PLASTIC SHRINK SOP (225mil)

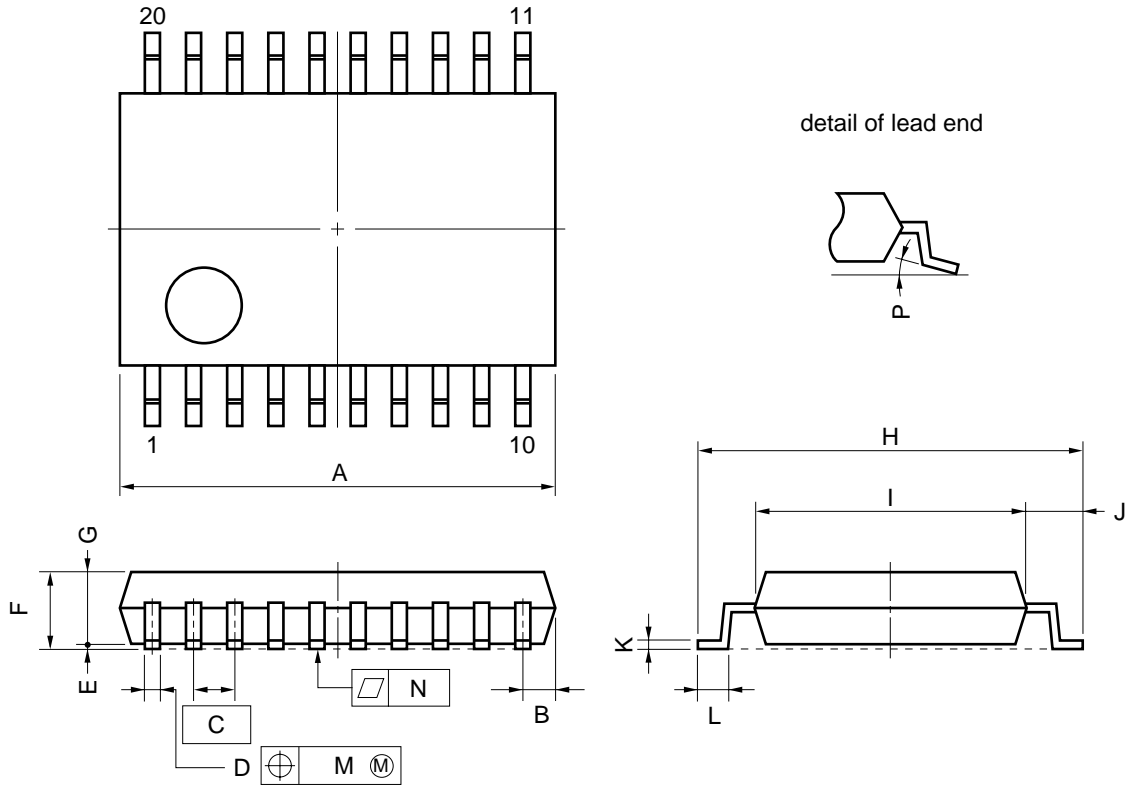

NOTE
 Each lead centerline is located within 0.10 mm (0.004 inch) of its true position (T.P.) at maximum material condition.

ITEM	MILLIMETERS	INCHES
A	7.00 MAX.	0.276 MAX.
B	0.575 MAX.	0.023 MAX.
C	0.65 (T.P.)	0.026 (T.P.)
D	0.22 ^{+0.10} _{-0.05}	0.009 ^{+0.004} _{-0.003}
E	0.1±0.1	0.004±0.004
F	1.45 MAX.	0.057 MAX.
G	1.15±0.1	0.045 ^{+0.005} _{-0.004}
H	6.4±0.2	0.252±0.008
I	4.4±0.1	0.173 ^{+0.005} _{-0.004}
J	1.0±0.2	0.039 ^{+0.009} _{-0.008}
K	0.15 ^{+0.10} _{-0.05}	0.006 ^{+0.004} _{-0.002}
L	0.5±0.2	0.020 ^{+0.008} _{-0.009}
M	0.10	0.004
N	0.10	0.004
P	3° ^{+7°} _{-3°}	3° ^{+7°} _{-3°}

P20GR-65-225C-1

★ **RECOMMENDED SOLDERING CONDITIONS**

When soldering this product, it is highly recommended to observe the conditions as shown below. If other soldering processes are used, or if the soldering is performed under different conditions, please make sure to consult with our sales offices.

For more details, refer to our document “**SEMICONDUCTOR DEVICE MOUNTING TECHNOLOGY MANUAL**” (C10535E).

Surface mount device

μPD16510GR-8JG: 20-pin plastic shrink SOP (225 mil)

Process	Conditions	Symbol
Infrared ray reflow	Peak temperature: 235 °C or below (Package surface temperature), Reflow time: 30 seconds or less (at 210 °C or higher), Maximum number of reflow processes: 3 times.	IR35-00-3
VPS	Peak temperature: 215 °C or below (Package surface temperature), Reflow time: 40 seconds or less (at 200 °C or higher), Maximum number of reflow processes: 3 times.	VP15-00-3
Wave soldering	Solder temperature: 260 °C or below, Flow time: 10 seconds or less, Maximum number of flow processes: 1 time, Pre-heating temperature: 120 °C or below (Package surface temperature).	WS60-00-1
Partial heating method	Pin temperature: 300 °C or below, Heat time: 3 seconds or less (Per each side of the device).	—

Caution Apply only one kind of soldering condition to a device, except for “partial heating method”, or the device will be damaged by heat stress.

[MEMO]

[MEMO]

[MEMO]

NOTES FOR CMOS DEVICES

① PRECAUTION AGAINST ESD FOR SEMICONDUCTORS

Note: Strong electric field, when exposed to a MOS device, can cause destruction of the gate oxide and ultimately degrade the device operation. Steps must be taken to stop generation of static electricity as much as possible, and quickly dissipate it once, when it has occurred. Environmental control must be adequate. When it is dry, humidifier should be used. It is recommended to avoid using insulators that easily build static electricity. Semiconductor devices must be stored and transported in an anti-static container, static shielding bag or conductive material. All test and measurement tools including work bench and floor should be grounded. The operator should be grounded using wrist strap. Semiconductor devices must not be touched with bare hands. Similar precautions need to be taken for PW boards with semiconductor devices on it.

② HANDLING OF UNUSED INPUT PINS FOR CMOS

Note: No connection for CMOS device inputs can be cause of malfunction. If no connection is provided to the input pins, it is possible that an internal input level may be generated due to noise, etc., hence causing malfunction. CMOS device behave differently than Bipolar or NMOS devices. Input levels of CMOS devices must be fixed high or low by using a pull-up or pull-down circuitry. Each unused pin should be connected to V_{DD} or GND with a resistor, if it is considered to have a possibility of being an output pin. All handling related to the unused pins must be judged device by device and related specifications governing the devices.

③ STATUS BEFORE INITIALIZATION OF MOS DEVICES

Note: Power-on does not necessarily define initial status of MOS device. Production process of MOS does not define the initial operation status of the device. Immediately after the power source is turned ON, the devices with reset function have not yet been initialized. Hence, power-on does not guarantee out-pin levels, I/O settings or contents of registers. Device is not initialized until the reset signal is received. Reset operation must be executed immediately after power-on for devices having reset function.

[MEMO]

The application circuits and their parameters are for reference only and are not intended for use in actual design-ins.

No part of this document may be copied or reproduced in any form or by any means without the prior written consent of NEC Corporation. NEC Corporation assumes no responsibility for any errors which may appear in this document.

NEC Corporation does not assume any liability for infringement of patents, copyrights or other intellectual property rights of third parties by or arising from use of a device described herein or any other liability arising from use of such device. No license, either express, implied or otherwise, is granted under any patents, copyrights or other intellectual property rights of NEC Corporation or others.

While NEC Corporation has been making continuous effort to enhance the reliability of its semiconductor devices, the possibility of defects cannot be eliminated entirely. To minimize risks of damage or injury to persons or property arising from a defect in an NEC semiconductor device, customers must incorporate sufficient safety measures in its design, such as redundancy, fire-containment, and anti-failure features.

NEC devices are classified into the following three quality grades:

"Standard", "Special", and "Specific". The Specific quality grade applies only to devices developed based on a customer designated "quality assurance program" for a specific application. The recommended applications of a device depend on its quality grade, as indicated below. Customers must check the quality grade of each device before using it in a particular application.

Standard: Computers, office equipment, communications equipment, test and measurement equipment, audio and visual equipment, home electronic appliances, machine tools, personal electronic equipment and industrial robots

Special: Transportation equipment (automobiles, trains, ships, etc.), traffic control systems, anti-disaster systems, anti-crime systems, safety equipment and medical equipment (not specifically designed for life support)

Specific: Aircrafts, aerospace equipment, submersible repeaters, nuclear reactor control systems, life support systems or medical equipment for life support, etc.

The quality grade of NEC devices is "Standard" unless otherwise specified in NEC's Data Sheets or Data Books. If customers intend to use NEC devices for applications other than those specified for Standard quality grade, they should contact an NEC sales representative in advance.

Anti-radioactive design is not implemented in this product.