



GS-R1005

50W STEP-DOWN SWITCHING REGULATOR

Type	V_i	V_o	I_o
GS-R1005	12 to 36 V	5 V	10 A

FEATURES

- Wide input voltage range (12 to 36V)
- High efficiency (80% min.)
- Parallel operation with current sharing
- Synchronization
- Remote inhibit/enable
- Remote load voltage sense
- Output short-circuit protection
- Soft-start
- PCB or chassis mountable

DESCRIPTION

The GS-R1005 is a step-down switching voltage regulator suitable to provide 5V/10A output voltage from a wide input voltage range (12 to 36V).

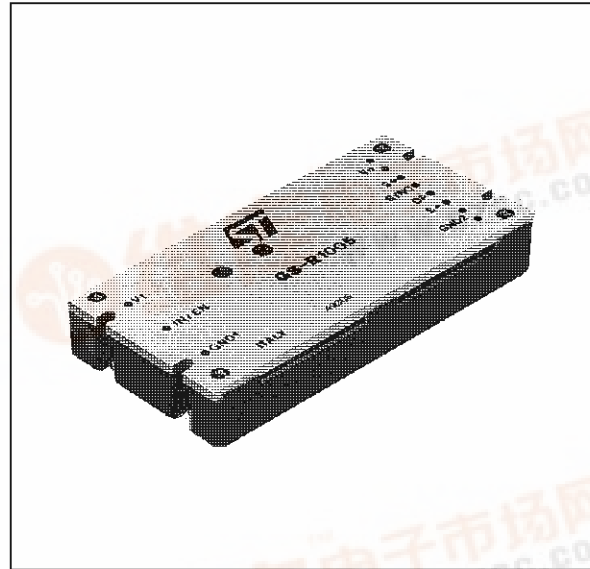

ABSOLUTE MAXIMUM RATINGS

Symbol	Parameter	Value	Unit
V_i	DC Input Voltage	40	V
V_{inh}	High Inhibit voltage	28	V
T_{cop}	Operating Case Temperature Range	0 to +75	°C
T_{stg}	Storage Temperature Range	- 20 to +105	°C

GS-R1005

ELECTRICAL CHARACTERISTICS ($T_{amb} = 25^{\circ}\text{C}$ unless otherwise specified)

Symbol	Parameter	Test Conditions	Min	Typ	Max	Unit
V_i	Input Voltage	$V_o = 5.05\text{V}$ $I_o = 1.2$ to 10A	12	24	36	V
I_i	Input Current	$V_i = 24\text{V}$ $I_o = 10\text{A}$		2.5		A
I_{ir}	Reflected Input Current	$V_i = 24\text{V}$ $I_o = 10\text{A}$ with external filter ($C = 470\mu\text{F}$)		200	220	mApp
V_{ien}	Enable Input Voltage	$V_i = 12$ to 36V $I_o = 1.2$ to 10A	0		1.2	V
V_{iinh}	Inhibit Input Voltage	$V_i = 12$ to 36V $I_o = 1.2$ to 10A	2		24	V
I_{iinh}	Inhibit Input Current	$V_i = 12$ to 36V $I_o = 1.2$ to 10A $V_{iinh} = 5\text{V}$		0.3	0.5	mA
V_o	Output Voltage	$V_i = 12$ to 36V $I_o = 1.2$ to 10A	4.9	5.05	5.2	V
V_{or}	Output Ripple Voltage	$V_i = 24\text{V}$ $I_o = 10\text{A}$		100	120	mVpp
δV_{OL}	Line Regulation	$V_i = 12$ to 36V $I_o = 10\text{A}$			0.5	%
δV_{OO}	Load Regulation	$V_i = 24\text{V}$ $I_o = 1.2$ to 10A			1	%
ΔV_o	Total Remote Sense Compensation	$V_i = 24\text{V}$ $I_o = 10\text{A}$			0.5	V
I_o	Output Current*	$V_i = 12$ to 36V $V_o = 5.05\text{V}$	0		10	A
I_{ol}	Output Current Limiting	$V_i = 12$ to 36V	12.5		13.7	A
I_{osc}	Short-circuit Output Current	$V_i = 24\text{V}$			16	A
δI_o	Current Sharing Deviation	$V_i = 24\text{V}$ $I_o = 2$ to 10A two modules in parallel			10	%
t_{ss}	Soft-start Time	$V_i = 24\text{V}$ $I_o = 10\text{A}$		15		ms
t_{r1}	Line Transient Recovery Time	$V_i = 12$ to 36V $I_o = 5\text{A}$		60		μs
t_{r2}	Load Transient Recovery Time	$V_i = 24\text{V}$ $I_o = 1.2$ to 10A		100		μs
f_s	Switching Frequency	$V_i = 24\text{V}$ $I_o = 1.2$ to 10A		100		kHz
η	Efficiency	$V_i = 12$ to 36V $I_o = 10\text{A}$	80	83		%
R_{thc}	Thermal Resistance Case-to-ambient			7.5		$^{\circ}\text{C}/\text{W}$

* Note: when output current is less than 1.2A, output ripple voltage increases due to discontinuous operation.

CONNECTION DIAGRAM AND MECHANICAL DATA

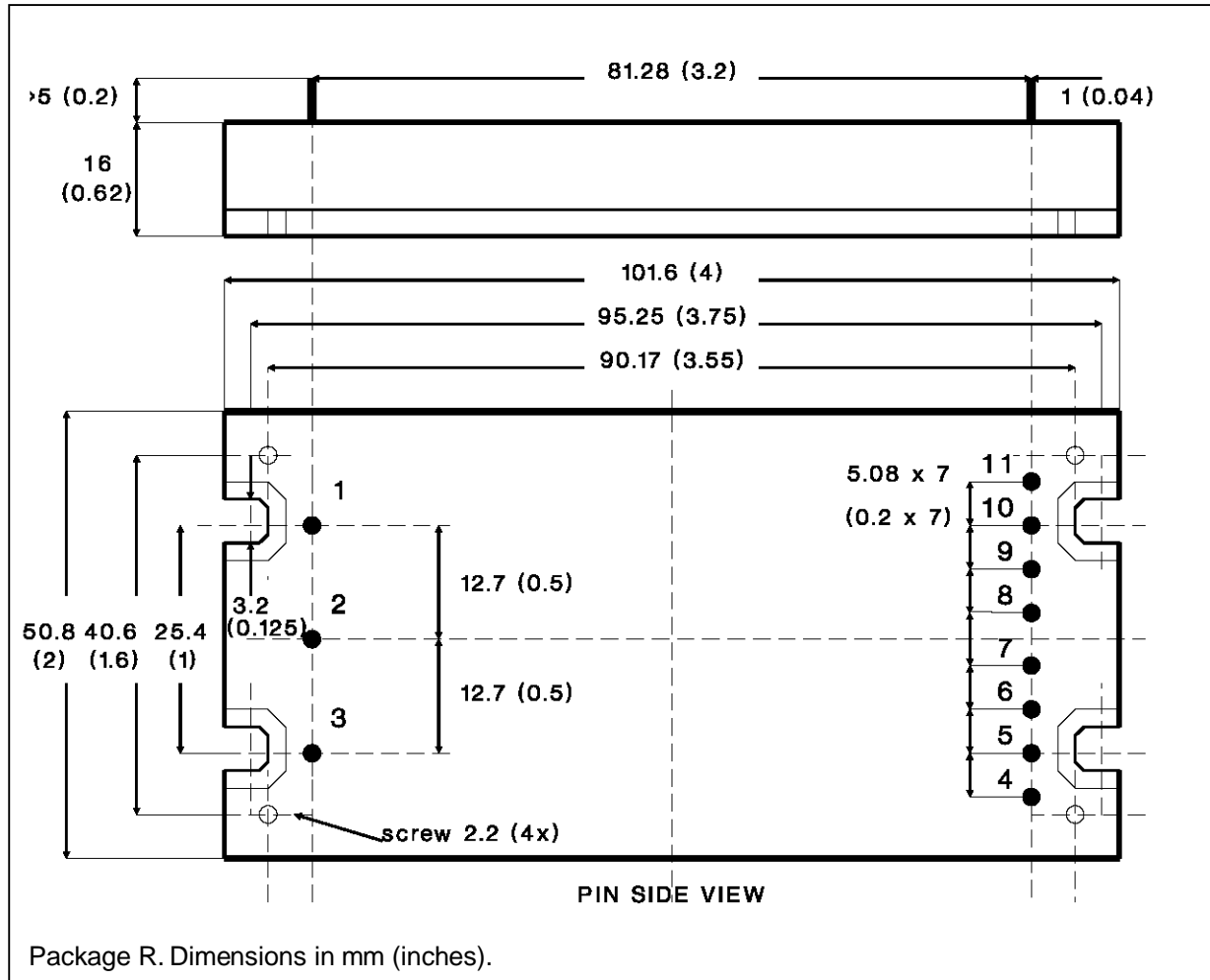

PIN DESCRIPTION

Pin	Function	Description
1	GND Input	Return for input voltage source. Internally connected to pin 10,11.
2	Inhibit	The converter is ON (Enable) when this pin is unconnected or the voltage applied is lower than 1.2V. The converter is OFF (Inhibit) for a control voltage in the range of 2 to 24V.
3	+ Vin	DC Input voltage; recommended maximum voltage is 36V. External capacitor between pin 3 and pin 1 is mandatory; recommended value is 470 μ F/50V for switching application.
4,5	+ Vout	+5V output voltage.
6	+ Sense	Senses the remote load high side. To be connected to pin 4,5 when remote sense is not used.
7	Sync	Synchronization output. See figures 1,2,3,4. Open when not used.
8	Parallel	Parallel output. See figures 1,2,3,4. Open when not used.
9	- Sense	Senses the remote load return. To be connected to pin 10,11 when remote sense is not used. In parallel configuration, take care to connect all -S pins together (see figures 1,2,3,4).
10,11	GND Output	Return for output current path. Internally connected to pin 1.

USER NOTES

Input Voltage

The recommended operating maximum DC input voltage is 36V inclusive of the ripple voltage. The use of an external low ESR, high ripple current capacitor located as close the module as possible is mandatory; recommended value is 470 μ F/50V.

Softstart

To avoid heavy inrush current the output voltage rise time is typically 15ms in any condition of load.

Remote Sensing

The remote voltage sense compensation range is for a total drop of 500mV equally shared between the load connecting wires. It is a good practice to shield the sensing wires to avoid oscillations. See the connection diagram on figures 1, 2, 3, 4.

Parallel Operation

To increase available output regulated power, the module features the parallel connection possibility with equal current sharing and maximum deviation of 10% (two modules in parallel). See the connection diagram on figures 1, 2, 3, 4.

Module Protection

The module is protected against occasional and permanent shortcircuits of the output pins to ground, as well as against output current overload. It uses a current limiting protection circuitry, avoiding latch-up problems with certain types of loads.

Figure 1.

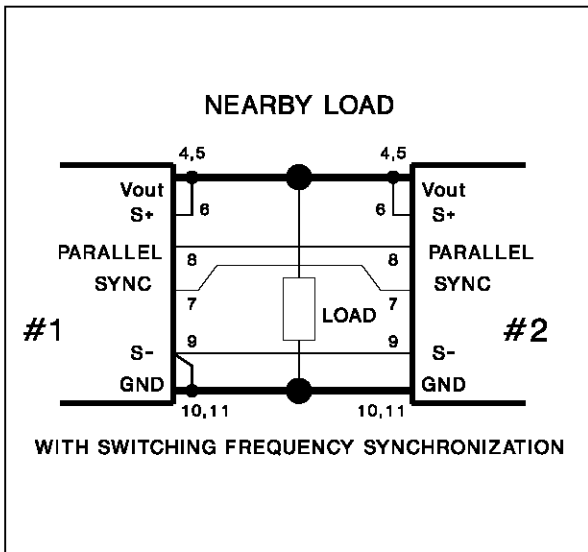

Figure 2.

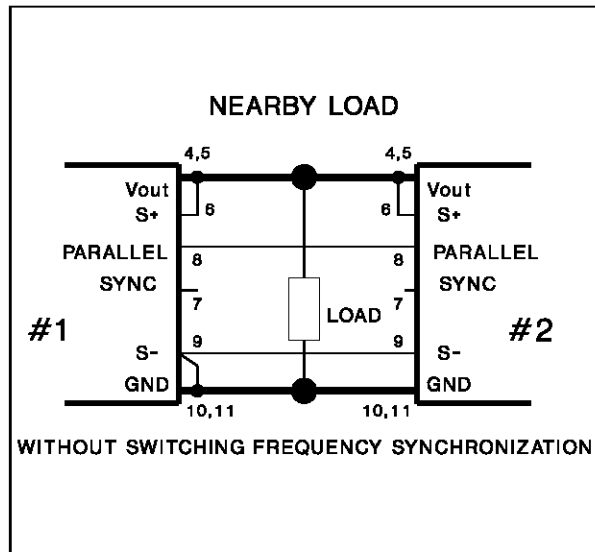

Figure 3.

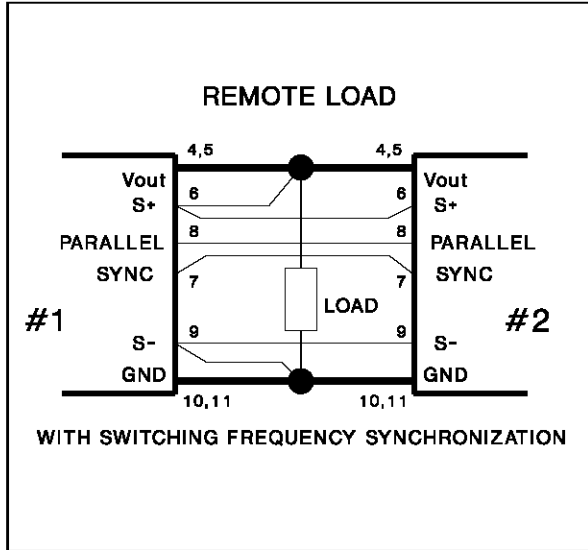
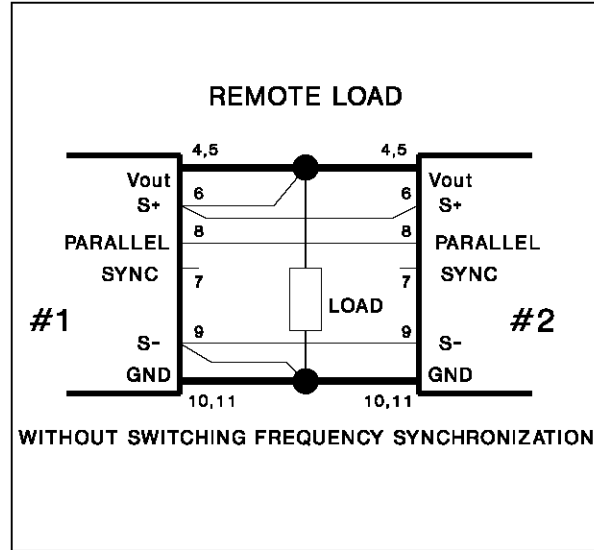

Figure 4.



Thermal characteristics: how to choose the heat-sink

Sometimes the GS-R1005 requires an external heat-sink depending on both operating temperature conditions and power.

Before entering into calculations details, some basic concepts will be explained to better understand the problem.

The thermal resistance between two points is represented by their temperature difference in front of a specified dissipated power, and it is expressed in Degree Centigrade per Watt (°C/W).

For GS-R1005 the thermal resistance case to ambient is 7.5°C/W. This means that an internal power dissipation of 1 W will bring the case temperature at 7.5°C above the ambient temperature.

The maximum case temperature, at which the module provides 10A, is 75°C (see fig. 6).

Let's suppose to have a GS-R1005 that delivers a load current of 10A at an ambient temperature of 40°C.

The dissipated power in this operating condition is about 10.2W (at typical efficiency of 83%), and the case temperature of the module will be:

$$T_{Case} = T_{Amb} + P_d \times R_{th} = 40 + 10.2 \times 7.5 = 116.8 \text{ } ^\circ\text{C}$$

This value exceeds the maximum allowed temperature and an external heat-sink must be added. To this purpose four holes (see mechanical drawing) are provided on the metal surface of the module.

To calculate this heat-sink, let's first determine what the total thermal resistance should be.

$$R_{th} = \frac{T_{CaseMAX} - T_{amb}}{P_d} = \frac{75 - 40}{10.2} = 3.42 \text{ } ^\circ\text{C} / \text{W}$$

This value is the resulting value of the additional heatsink thermal resistance.

Figure 5. - Efficiency vs. Output Current.

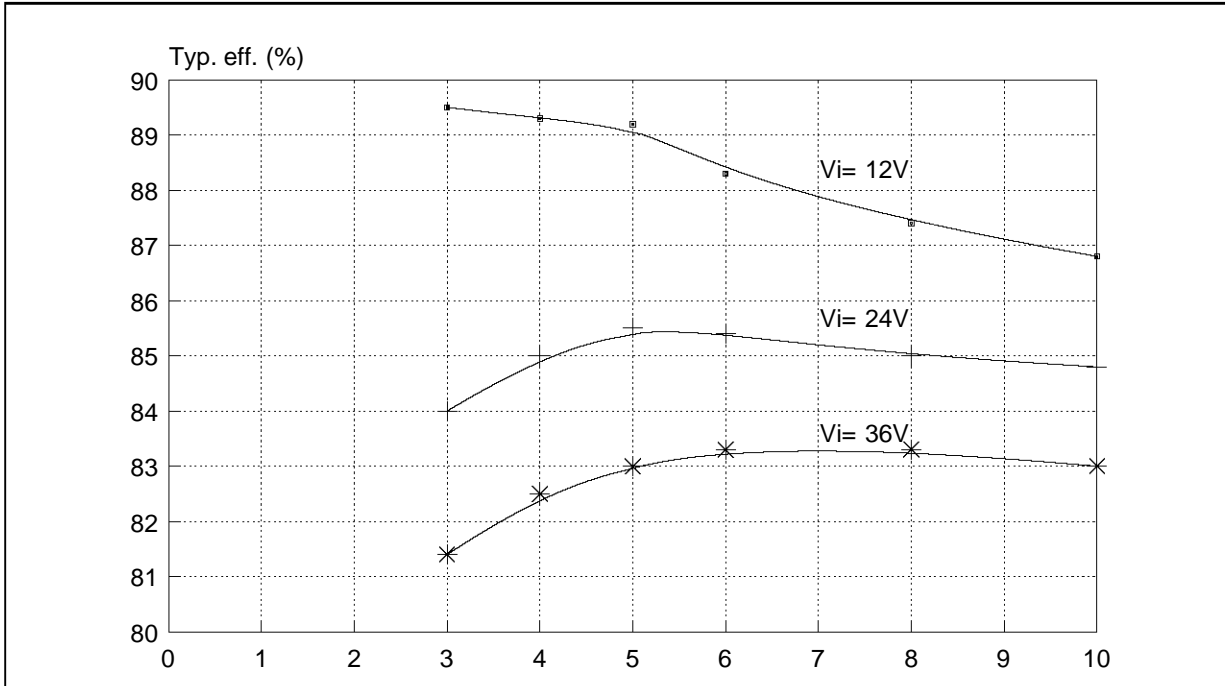
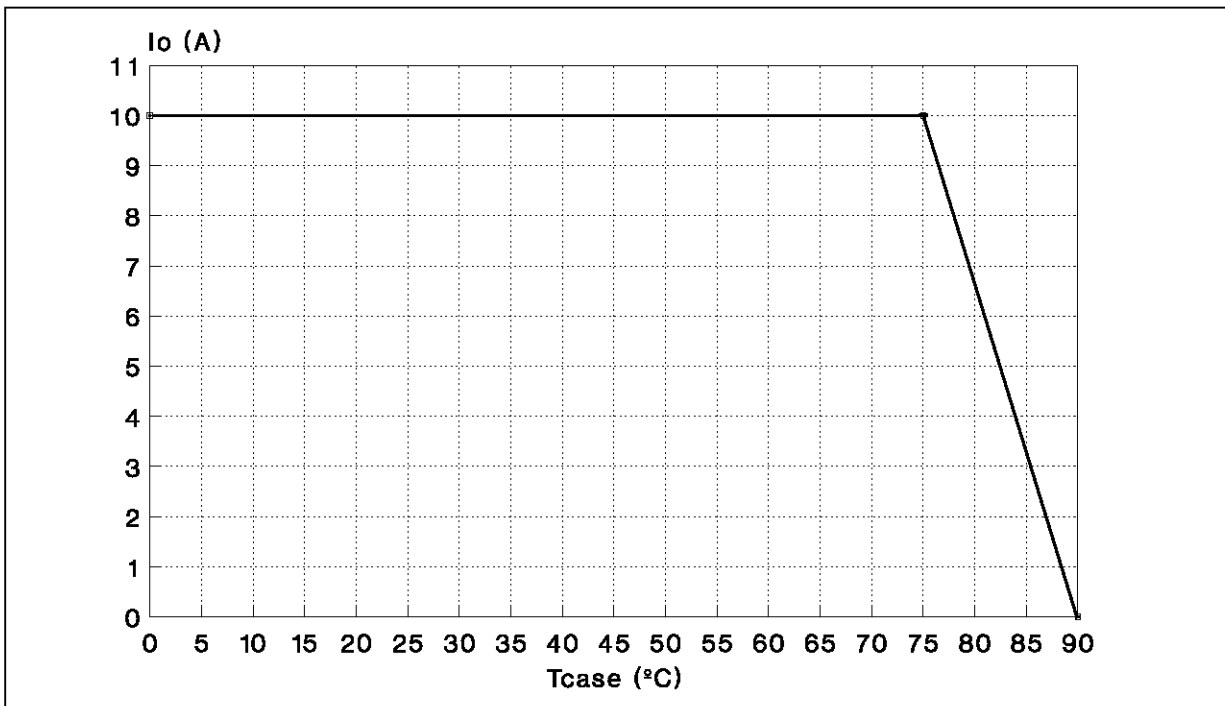

Figure 6. - Output Current vs. T case.



The following list may help the designer to select the proper commercially available heat-sink. Sometimes it can be more convenient to use a custom made heat-sink that can be experimentally designed and tested.

Manufacturers	Type	Height (mm)	Rth (°C/W)
ALUTRONIC	PR139	20	3
	PR140	19	2
	PR159	20	2.5
ASSMAN	V5440	19	3
	V5805	15	2
	V5280	19	2
AAVID	60885	14	4.5
	60660	25.5	1.5
	62355	33.5	3
AUSTERLITZ	KS50	12	3
	KS100.3	15	2.5
FISCHER	SK16	25.5	1.5
	SK52	19	2
SGE BOSARI	L30	21	3
	LZ50	24	3
THERMALLOY	6155	14	4.5
	6601	14	5
	6176	24	4.5
	6320	30	1.5

Information furnished is believed to be accurate and reliable. However, SGS-THOMSON Microelectronics assumes no responsibility for the consequences of use of such information nor for any infringement of patents or other rights of third parties which may result from its use. No license is granted by implication or otherwise under any patent or patent rights of SGS-THOMSON Microelectronics. Specification mentioned in this publication are subject to change without notice. This publication supersedes and replaces all information previously supplied. SGS-THOMSON Microelectronics products are not authorized for use as critical components in life support devices or systems without express written approval of SGS-THOMSON Microelectronics.

© 1994 SGS-THOMSON Microelectronics – All Rights Reserved

SGS-THOMSON Microelectronics GROUP OF COMPANIES
Australia - Brazil - China - France - Germany - Hong Kong - Italy - Japan - Korea - Malaysia - Malta - Morocco - The Netherlands - Singapore - Spain - Sweden - Switzerland - Taiwan - Thailand - United Kingdom - U.S.A.