

20W TRIPLE OUTPUT STEP-DOWN SWITCHING REGULATOR

FEATURES

- MTBF in excess of 200,000 hours
- 4V max drop-out voltage
- Soft start
- Reset output
- Non-latching short circuit protection
- Crow-bar output overvoltage protection

DESCRIPTION

The GS-R51212 is a versatile triple output, high current, high voltage step-down switching regulator module that provides a +5V and two isolated 12V outputs. It is ideal for microprocessor based boards because it powers the logic and the communication ports and it has a Reset output for the correct system start-up.

The integral heatsink allows a large power handling capability and it provides also an effective shielding to minimize EMI.



MAIN CHARACTERISTICS

V_i	Input Voltage	9 to 40V
V_{o1} I_{o1}	Output Voltage Output Current	5.1V 3.5A
V_{o2} I_{o2}	Output Voltage Output Current	12V 0.1A
V_{o3} I_{o3}	Output Voltage Output Current	12V 0.1A

ABSOLUTE MAXIMUM RATINGS

Symbol	Parameter	Value	Unit
V_i	DC Input Voltage	42	V
I_{rt}	Reset Output Sink Current	20	mA
T_{stg}	Storage Temperature Range	- 40 to +105	°C
T_{cop}	Operating Case Temperature Range	- 20 to +85	°C

ELECTRICAL CHARACTERISTICS ($T_A = 25^\circ\text{C}$ unless otherwise specified)

Symbol	Parameter	Test Conditions	Min	Typ	Max	Unit
V_{O1}	Output Voltage	$V_i = 24\text{V}$ $I_{O1} = 2.5\text{A}$	4.95	5.1	5.2	V
V_{O2}	Output Voltage	$V_i = 24\text{V}$ $I_{O2} = 0.1\text{A}$	11.5		12.5	V
V_{O3}	Output Voltage	$V_i = 24\text{V}$ $I_{O3} = 0.1\text{A}$	11.5		12.5	V
$\Delta V_O/\Delta T$	Temperature Stability	All Outputs		0.2		mV/°C
V_i	Input Voltage		9		40	V
I_{O1}	Output Current	$V_i = 24\text{V}$	0.5		3.5	A
I_{O2}	Output Current	$V_i = 24\text{V}$			0.1	A
I_{O3}	Output Current	$V_i = 24\text{V}$			0.1	A
I_{isc}	Average Input Current	$V_i = 40\text{V}$ $V_{O1} = 0\text{V}$		0.1	0.2	A
I_{isc}	Average Input Current	$V_i = 40\text{V}$ $V_{O1/2/3} = 0\text{V}$		0.1	0.2	A
I_{ir}	Reflected Input Current	$V_i = 24\text{V}$ $I_{O1} = 2.5\text{A}$ $I_{O2,3} = 0.1\text{A}$		200		mApp
V_{is}	5V to 12V Isolation Voltage		200			VDC
f_s	Switching Frequency			100		kHz
η	Efficiency	$V_i = 24\text{V}$ $I_{O1} = 2.5\text{A}$ $I_{O2,3} = 0.1\text{A}$		70		%
ΔV_O	Line Regulation	$I_{O1} = 2.5\text{A}$ $V_i = 15$ to 25V $I_{O2,3} = 0.1\text{A}$		2		mV/V
ΔV_O	Load Regulation	$V_i = 24\text{V}$ $I_{O1} = 0.5$ to 2.5A $V_i = 24\text{V}$ $I_{O2,3} = 0.05$ to 0.1A		35 600		mV/A
SVR	Supply Voltage Rejection	50/60Hz		4		mV/V
V_{or}	Output Ripple Voltage	$V_i = 24\text{V}$ $I_{O1} = 2.5\text{A}$		30		mVpp
V_{on}	Output Noise Voltage	$V_i = 24\text{V}$ $I_{O1} = 2.5\text{A}$		40		mVpp
I_{rh}	Reset Leakage Current			100		μA
V_{rl}	Reset Low Level	$I_{reset} = 5\text{mA}$		0.2		V
t_{rd}	Reset Delay Time			100		ms
t_{r1}	Line Transient Recovery Time	$I_{O1} = 2.5\text{A}$ $V_i = 15$ to 35V		500		μs
t_{r2}	Load Transient Recovery Time	$V_i = 24\text{V}$ $I_O = 0.5$ to 2.5A		200		μs
t_{ss}	Soft Start Time			10		ms
t_{cd}	Crowbar Delay Time			5		μs
V_{cth}	Crowbar Intervention Threshold			6.37		V
R_{th}	Thermal Resistance	Case to ambient		5		°C/W

CONNECTION DIAGRAM AND MECHANICAL DATA

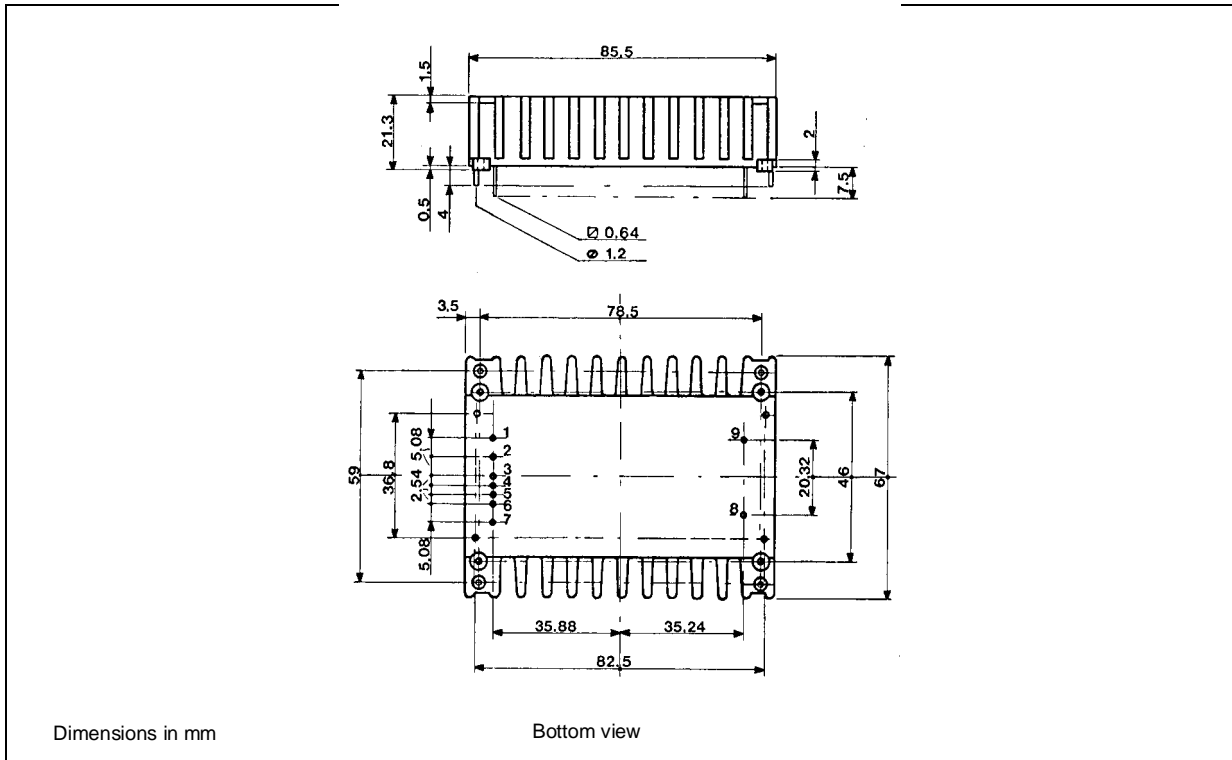

PIN DESCRIPTION

Pin	Function	Description
1	Output 1	Regulated 5.1V output.
2	Output GND	Return for output1 current path. Internally connected to pin 8.
3	Output 2	Regulated 12V output.
4	Ground 2	Return of output 3 current path.
5	Output 3	Regulated 12V output.
6	Ground 3	Return of output 3 current path.
7	Reset	Open collector Reset output.
8	Input GND	Return of input voltage source. Internally connected to pin 2.
9	+ Input	DC input voltage. Recommended maximum voltage is 40V.

USER NOTES

Input Voltage

The recommended operating maximum DC input voltage is 40V inclusive of the ripple voltage.

Case Grounding

The module case is internally connected to pin 2 and pin 8. The PCB area below the module can be used as an effective sixth side shield against EMI.

Thermal Characteristics

The case-to-ambient thermal resistance of the GS-R51212 module is about 5°C/W. This produces a 50°C temperature increase of the module surface for a 10W of internal power dissipation. Depending on the ambient temperature and/or on the power dissipation, an additional heatsink or forced ventilation may be required.

Input Impedance

The module has an internal capacitor connected between the input pins in order to assure PWM stability. This capacitor cannot handle large values of high frequency ripple current, and it can be permanently damaged if the primary energy source impedance is not adequate.

The use of an external low ESR, high ripple current capacitor located as close to the module as possible is recommended. Suitable capacitors should have a RMS current capability of 2,5 A_{RMS} with a working voltage of 50 V_{DC} and an ESR of 0,1Ω at 100 kHz. When space is a limitation, a 22μF ceramic multilayer capacitor must be connected to the module input pins.

Module Protection

The module is protected against occasional and permanent short circuits of the output pins to ground, as well as against output current overload. When the output current at 5V output exceeds the maximum value, the output is automatically disabled. After a fixed time the module starts again in a soft mode. The cycle is repeated until the overload condition is removed.

A crow-bar output overvoltage protection is activated when the output voltage on V_{O1} exceeds 6.37V.

Output Current

The output current of the main output is 3.5A. The max output current of the two 12V outputs is a function of the input voltage and of the main output current as shown in fig. 1. If the main current is zero, no voltage will be available on the 12V outputs.

Figure 1. Output Current Capability vs. Operating Conditions

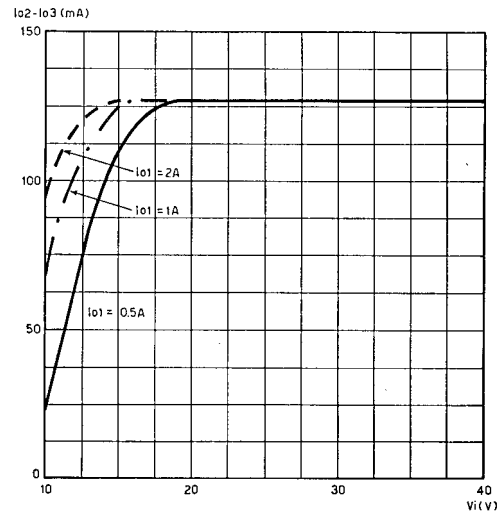

Figure 2. Reset Operation

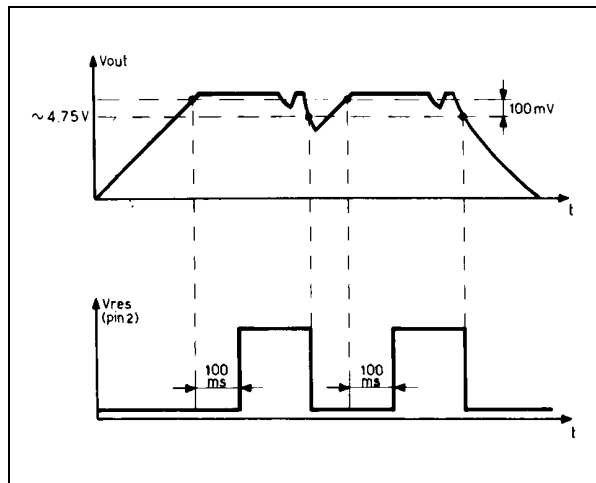
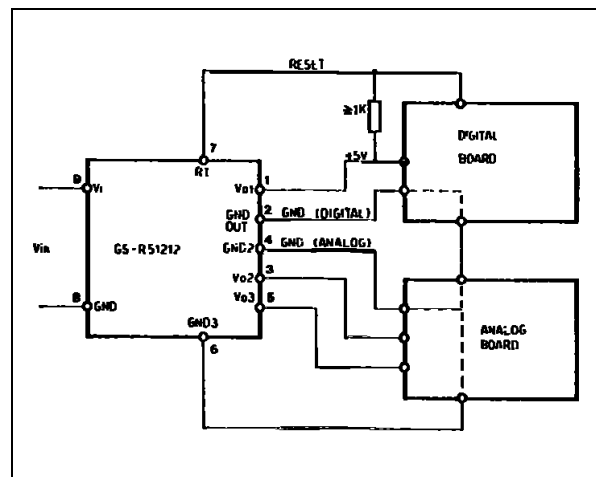

Figure 3. Typical application



Information furnished is believed to be accurate and reliable. However, SGS-THOMSON Microelectronics assumes no responsibility for the consequences of use of such information nor for any infringement of patents or other rights of third parties which may result from its use. No license is granted by implication or otherwise under any patent or patent rights of SGS-THOMSON Microelectronics. Specification mentioned in this publication are subject to change without notice. This publication supersedes and replaces all information previously supplied. SGS-THOMSON Microelectronics products are not authorized for use as critical components in life support devices or systems without express written approval of SGS-THOMSON Microelectronics.

© 1994 SGS-THOMSON Microelectronics – All Rights Reserved

SGS-THOMSON Microelectronics GROUP OF COMPANIES

Australia - Brazil - China - France - Germany - Hong Kong - Italy - Japan - Korea - Malaysia - Malta - Morocco - The Netherlands -
Singapore - Spain - Sweden - Switzerland - Taiwan - Thailand - United Kingdom - U.S.A.