



New Product

GS1084

Vishay
formerly General Semiconductor

5A Low Dropout Positive Adjustable Regulator

TO-252
(DPak)

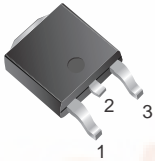

GS1084CE

TO-220AB

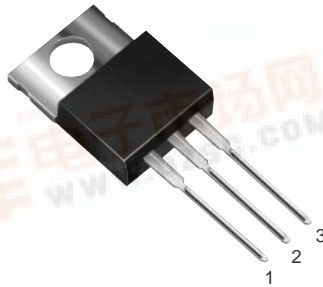

GS1084CT

TO-263AB
(D²Pak)

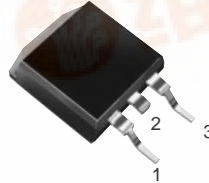

GS1084CM

Pin Definition

1. Adjust/Gnd.
2. V_{out} (tab)
3. V_{in}

Features

- Dropout Voltage 1.3V at 5A Output Current
- Fast Transient Response
- Line Regulation typically at 0.015%
- Load Regulation typically at 0.1%
- Internal thermal and current limiting
- Adjustable Output Voltage or Fixed 1.8V, 2.5V, 3.3V
- Standard 3-Pin Power Packages

Functional Block Diagram

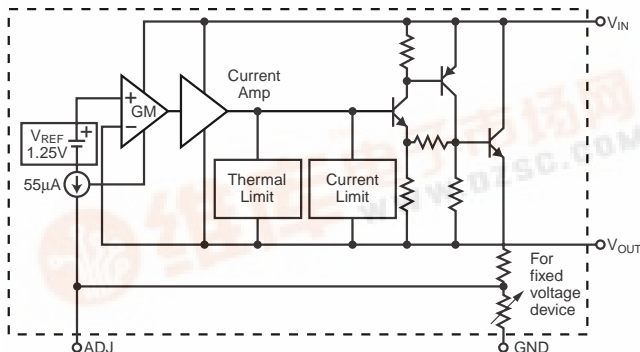

Description

The GS1084 is a low dropout three terminal regulator with 5A output current capability. The output voltage is adjustable with the use of a resistor divider. For fixed output voltage versions, the output voltage is internally set at 1.8V, 2.5V, or 3.3V. Dropout is guaranteed at a maximum of 1.4V at maximum output current. Its low dropout voltage and fast transient response make it ideal for low voltage microprocessor applications. Internal current and thermal limiting provides protection against any overload condition that would create excessive junction temperatures.

Applications

- Post Regulator for Switching Supply
- Microprocessor Power Supplies
- Constant-Current Regulators
- Motherboard I/O Power Supplies

Mechanical Data

Case: TO-220AB, TO-263AB (D²PAK), TO-252 (DPAK)

High temperature soldering guaranteed:
260°C/10 seconds at terminals

Case outlines are on the back page



GS1084

Vishay
formerly General Semiconductor



Maximum Ratings and Thermal Characteristics (T_A = 25°C unless otherwise noted)

Parameter	Symbol	Value	Unit
Vin Pin to ADJ/GND Pin	V _{in}	7	V
Thermal Resistance – Junction to Case	R _{θJC}	3.0 8.0 3.0	°C/W
Operating Junction Temperature Range	T _J	0 to +125	°C
Storage Temperature Range	T _{stg}	–65 to 150	°C

Electrical Characteristics ⁽¹⁾ T_J = 25°C ⁽²⁾ V_{IN} = 5V, I_o = 10mA unless otherwise noted.

Parameter	Symbol	Test Conditions	Min	Typ	Max	Unit
Reference Voltage	V _{REF}	T _J = 25°C 0°C ≤ T _J ≤ 125°C 2.65V ≤ V _{IN} ≤ 7V 10mA ≤ I _o ≤ 5A	1.238 1.225	1.250 1.250	1.262 1.275	V
Output Voltage	V _{OUT}	GS1084-1.8 V _{IN} = 5V GS1084-2.5 V _{IN} = 5V GS1084-3.3 V _{IN} = 7V GS1084 0°C ≤ T _J ≤ 125°C 2.65V ≤ V _{IN} ≤ 7V 10mA ≤ I _o ≤ 5A	1.78 2.47 3.26 0.98V _N	1.8 2.5 3.3 V _N	1.82 2.53 3.33 1.02V _N	V
Line Regulation	REG _{line}	2.65V ≤ V _{IN} ≤ 7V T _J = 25°C 0°C ≤ T _J ≤ 125°C		0.015 0.035	0.2 0.2	% V _O
Load Regulation	REG _{load}	10mA ≤ I _o ≤ 5A T _J = 25°C 0°C ≤ T _J ≤ 125°C		0.1 0.2	0.3 0.4	% V _O
Dropout Voltage	V _{DROP}	0°C ≤ T _J ≤ 125°C I _o = 5A I _o = 3A I _o = 1A		1.3 1.23 1.15	1.4 1.32 1.25	V
Output Current	I _o	0°C ≤ T _J ≤ 125°C	5.0	6.0	–	A
Adjust Pin Current	I _{adj}	2.65 ≤ V _{in} ≤ 7V 10mA ≤ I _o ≤ 5A 0°C ≤ T _J ≤ 125°C	–	55	120	μA
Adjust Pin Current Change	ΔI _{adj}	2.65 ≤ V _{in} ≤ 7V 10mA ≤ I _o ≤ 5A 0°C ≤ T _J ≤ 125°C	–	0.2	5	μA
Temperature Stability	T _S	I _o = 0.5A, 0°C ≤ T _J ≤ 125°C	–	0.8	–	%V _O
Min. Load Current Adjustable Version	I _{LMIN}	0°C ≤ T _J ≤ 125°C	–	3	10	mA



Electrical Characteristics (con't.)⁽¹⁾ $T_J = 25^\circ\text{C}$ ⁽²⁾, $V_{IN} = 5\text{V}$, $I_o = 10\text{mA}$ unless otherwise noted.

Parameter	Symbol	Test Conditions	Min	Typ	Max	Unit
Quiescent Current Fixed Voltage Version	I_Q	$0^\circ\text{C} \leq T_J \leq 125^\circ\text{C}$	–	10	14	mA
RMS Output Noise	N	$10\text{Hz} \leq f \leq 10\text{kHz}$	–	0.003	–	% V_O
Ripple Rejection Ratio	RR	$f = 120\text{Hz}$, $C_O = 25\mu\text{F}$ $C_{adj} = 25\mu\text{F}$	60	68	–	dB
Thermal Regulation	R_{TH}	$T_A = 25^\circ\text{C}$, 30ms Pulse	–	0.02	0.05	%/W
Long Term Stability		$T_A = 125^\circ\text{C}$, 1000 Hrs	–	0.3	–	% V_O

Notes:

- (1) All parameters, except nominal output voltage are specified for the variable voltage version, allowing a wider V_{IN} Range.
The specified limits also apply for the fixed voltage versions over the allowable input voltage range: GS1084-1.8 (3.2V - 7.0V), GS1084-2.5 (3.9V - 7.0V), GS1084-3.3 (4.75V - 7.0V).
- (2) To maintain the specified junction temperatures, low duty cycle pulse testing is required for most parameters.

Typical Application Circuit

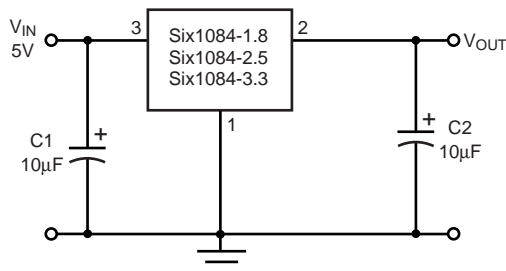

Fixed Voltage Regulator

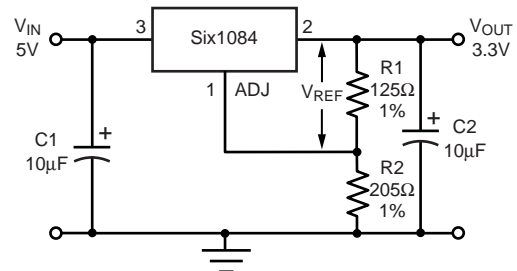

Adjustable Voltage Regulator

Notes:

$V_{REF} = V_{OUT} - V_{ADJ} = 1.25\text{V}$ (typ.)
 $V_{OUT} = V_{REF} \times (1 + R2/R1) + I_{ADJ} \times R2$
 $I_{ADJ} = 55\mu\text{A}$ (typ.)

- (1) C1 needed if device is far away from filter capacitors
- (2) C2 required for stability

Ratings and Characteristic Curves ($T_A = 25^\circ\text{C}$ unless otherwise noted)

Fig. 1 – Dropout Voltage vs. Output Current

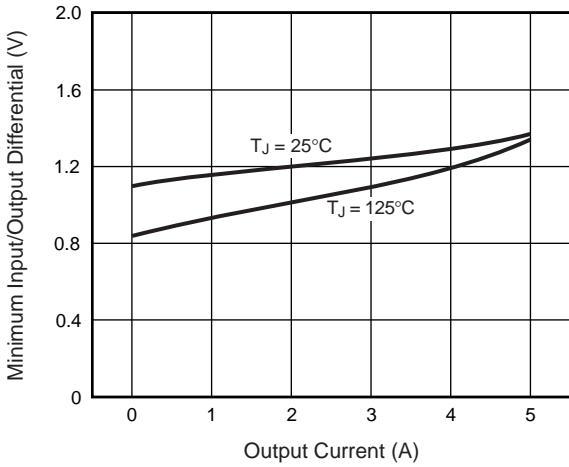

Fig. 2 – Load Regulation vs. Temperature

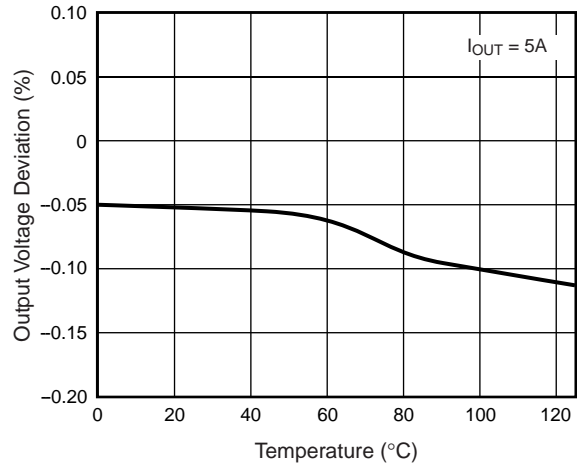

Fig. 3 – Minimum Load Current (Adjustable Version)

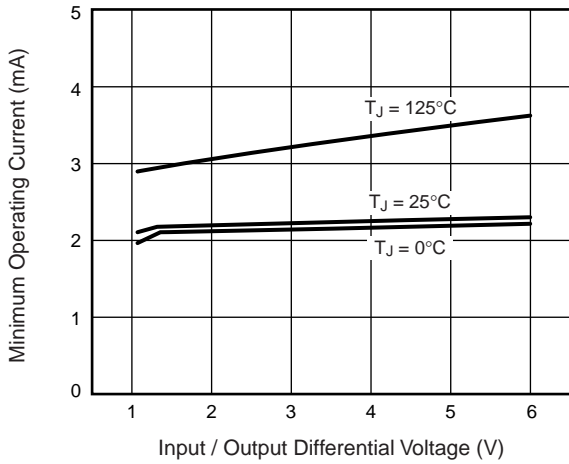

Fig. 4 – Adjust Pin Current

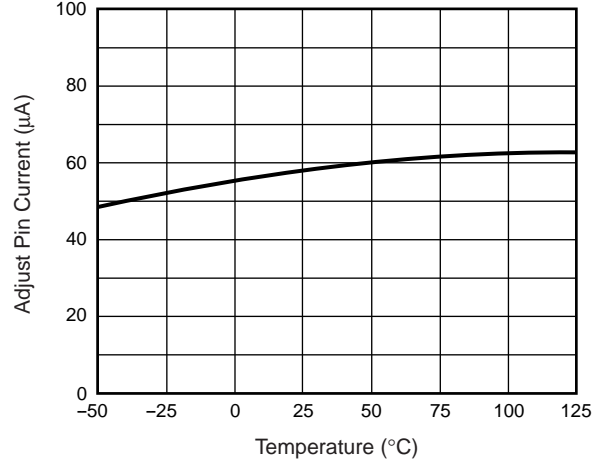

Fig. 5 – Temperature Stability

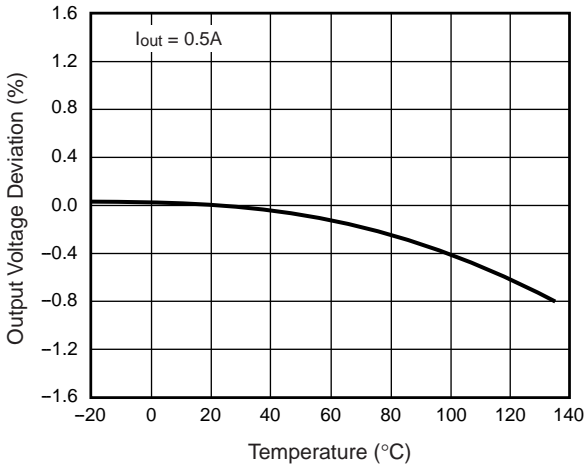
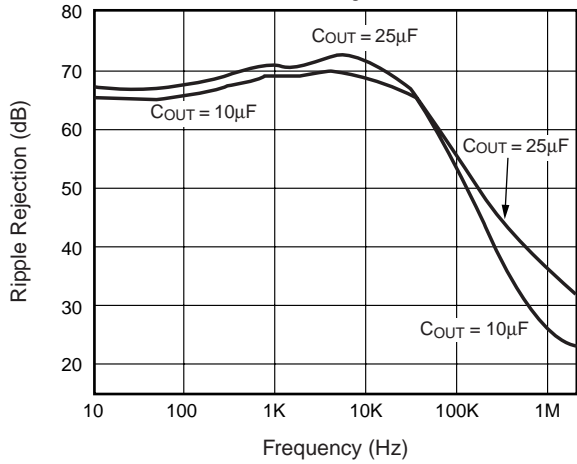

Fig. 6 – Ripple Rejection (with $C_{adj} 25\mu\text{F}$)





**Ratings and
Characteristic Curves** ($T_A = 25^\circ\text{C}$ unless otherwise noted)

Fig. 7 – Load Transient Response

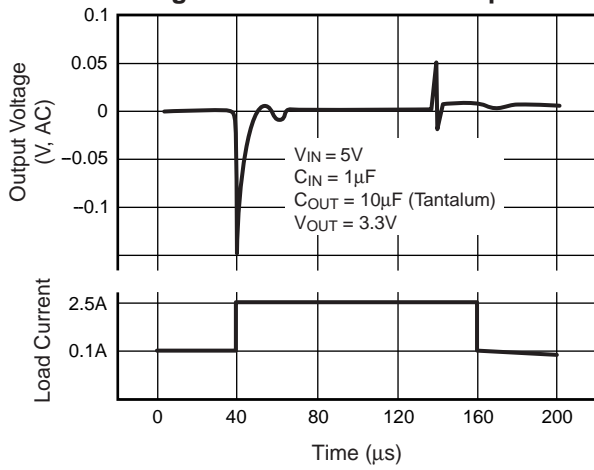
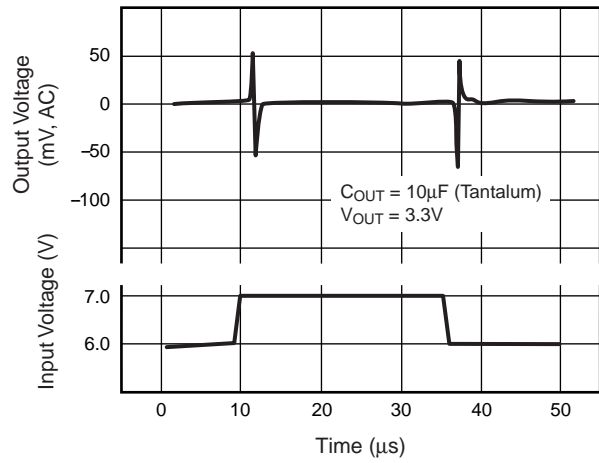

Fig. 8 – Line Transient Response



Ordering Information

GS1084Cxx xxx

Output Voltage
Default: Adj.
1.8: 1.8V
2.5: 2.5V
3.3: 3.3V

Package Type
T: TO-220
M: TO-263
E: TO-252

GS1084

Vishay
formerly General Semiconductor



Case Outlines

TO-252 (DPAK)

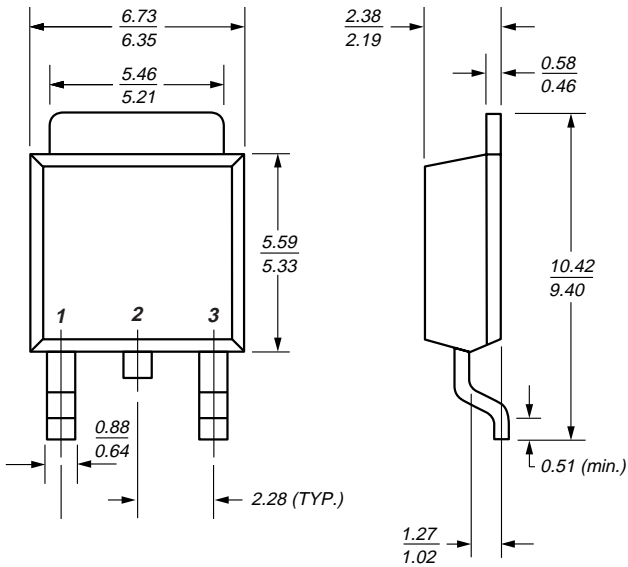

TO-220 Case Outline

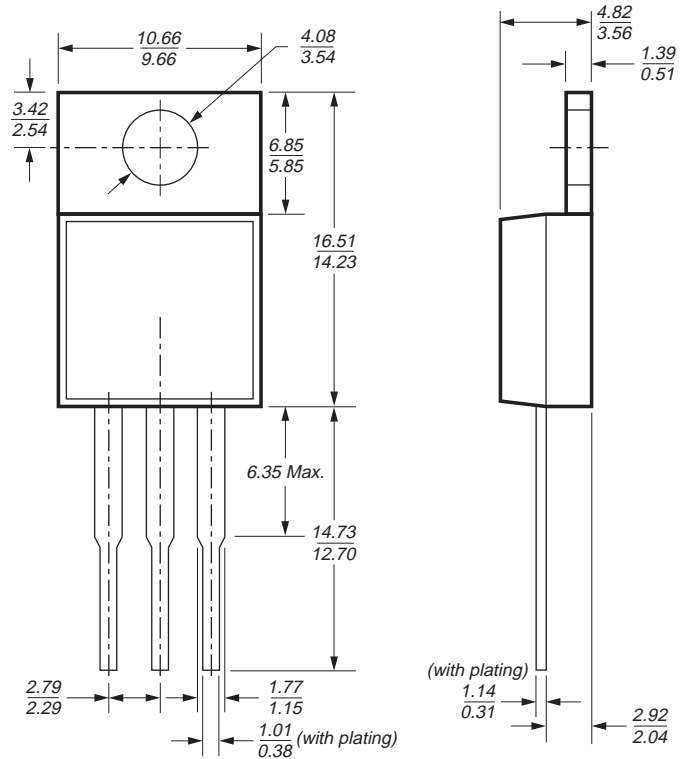

TO-263 Case Outline

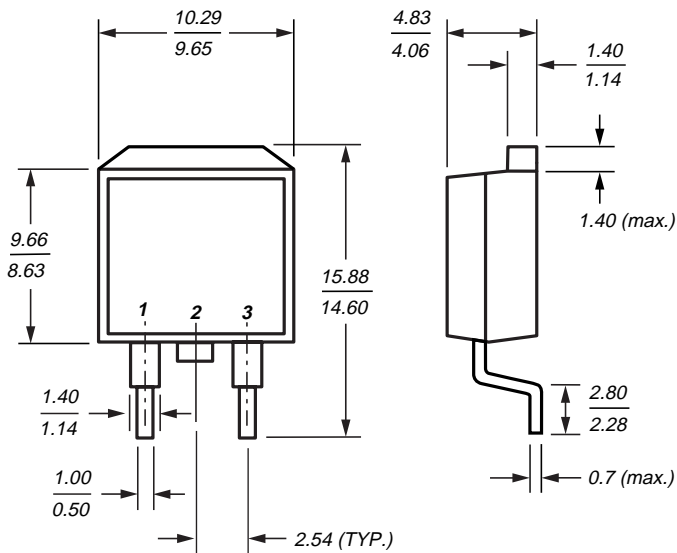

Dimensions in millimeters