



Integrated Silicon Pressure Sensor On-Chip Signal Conditioned, Temperature Compensated and Calibrated

The MPX5050 series piezoresistive transducer is a state-of-the-art monolithic silicon pressure sensor designed for a wide range of applications, but particularly those employing a microcontroller or microprocessor with A/D inputs. This patented, single element transducer combines advanced micromachining techniques, thin-film metallization, and bipolar processing to provide an accurate, high level analog output signal that is proportional to the applied pressure.

Features

- 2.5% Maximum Error over 0° to 85°C
- Ideally suited for Microprocessor or Microcontroller-Based Systems
- Temperature Compensated Over -40° to +125°C
- Patented Silicon Shear Stress Strain Gauge
- Durable Epoxy Unibody Element
- Easy-to-Use Chip Carrier Option

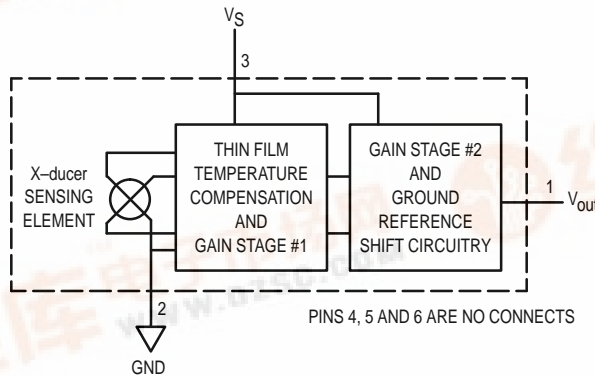

Figure 1. Fully Integrated Pressure Sensor Schematic

MAXIMUM RATINGS(1)

Parametrics	Symbol	Value	Unit
Overpressure ⁽²⁾ (P1 > P2)	P _{max}	200	kPa
Burst Pressure ⁽²⁾ (P1 > P2)	P _{burst}	700	kPa
Storage Temperature	T _{stg}	-40° to +125°	°C
Operating Temperature	T _A	-40° to +125°	°C

1. T_C = 25°C unless otherwise noted.
2. Exposure beyond the specified limits may cause permanent damage or degradation to the device.

MPX5050 SERIES

OPERATING OVERVIEW
INTEGRATED
PRESSURE SENSOR
 0 to 50 kPa (0 to 7.25 psi)
 0.2 to 4.7 Volts Output

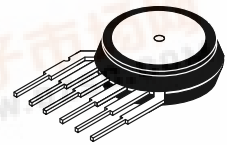

BASIC CHIP CARRIER
ELEMENT
CASE 867-08, STYLE 1

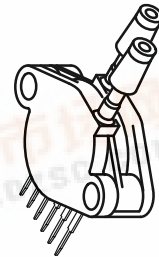

DIFFERENTIAL PORT OPTION
CASE 867C-05, STYLE 1

NOTE: Pin 1 is the notched pin.

PIN NUMBER			
1	V _{out}	4	N/C
2	Grd	5	N/C
3	V _S	6	N/C

NOTE: Pins 4, 5, and 6 are internal device connections. Do not connect to external circuitry or ground.



MPX5050 SERIES

OPERATING CHARACTERISTICS ($V_S = 5.0$ Vdc, $T_A = 25^\circ\text{C}$ unless otherwise noted, $P_1 > P_2$)

Characteristic	Symbol	Min	Typ	Max	Unit
Pressure Range ⁽¹⁾	P _{OP}	0	—	50	kPa
Supply Voltage ⁽²⁾	V _S	4.75	5.0	5.25	Vdc
Supply Current	I _o	—	7.0	10.0	mAdc
Minimum Pressure Offset ⁽³⁾ @ V _S = 5.0 Volts (0 to 85°C)	V _{off}	0.088	0.20	0.313	Vdc
Full Scale Output ⁽⁴⁾ @ V _S = 5.0 Volts (0 to 85°C)	V _{F_{SO}}	4.587	4.70	4.813	Vdc
Full Scale Span ⁽⁵⁾ @ V _S = 5.0 Volts (0 to 85°C)	V _{F_{SS}}	—	4.50	—	Vdc
Accuracy ⁽⁶⁾	—	—	—	±2.5	%V _{F_{SS}}
Sensitivity	V/P	—	90	—	mV/kPa
Response Time ⁽⁷⁾	t _R	—	1.0	—	mS
Output Source Current at Full Scale Output	I _{o+}	—	0.1	—	mAdc
Warm-Up Time ⁽⁸⁾	—	—	20	—	mSec
Offset Stability ⁽⁹⁾	—	—	±0.5	—	%V _{F_{SS}}

Decoupling circuit shown in Figure 4 required to meet electrical specifications.

MECHANICAL CHARACTERISTICS

Characteristic	Symbol	Min	Typ	Max	Unit
Weight, Basic Element (Case 867)	—	—	4.0	—	Grams
Common Mode Line Pressure ⁽¹⁰⁾	—	—	—	690	kPa

NOTES:

- 1.0kPa (kiloPascal) equals 0.145 psi.
- Device is ratiometric within this specified excitation range.
- Offset (V_{off}) is defined as the output voltage at the minimum rated pressure.
- Full Scale Output (V_{F_{SO}}) is defined as the output voltage at the maximum or full rated pressure.
- Full Scale Span (V_{F_{SS}}) is defined as the algebraic difference between the output voltage at full rated pressure and the output voltage at the minimum rated pressure.
- Accuracy (error budget) consists of the following:
 - Linearity: Output deviation from a straight line relationship with pressure over the specified pressure range.
 - Temperature Hysteresis: Output deviation at any temperature within the operating temperature range, after the temperature is cycled to and from the minimum or maximum operating temperature points, with zero differential pressure applied.
 - Pressure Hysteresis: Output deviation at any pressure within the specified range, when this pressure is cycled to and from minimum or maximum rated pressure at 25°C.
 - TcSpan: Output deviation over the temperature range of 0° to 85°C, relative to 25°C.
 - TcOffset: Output deviation with minimum pressure applied, over the temperature range of 0° to 85°C, relative to 25°C.
 - Variation from Nominal: The variation from nominal values, for Offset or Full Scale Span, as a percent of V_{F_{SS}} at 25°C.
- Response Time is defined as the time for the incremental change in the output to go from 10% to 90% of its final value when subjected to a specified step change in pressure.
- Warm-up is defined as the time required for the product to meet the specified output voltage after the Pressure has been stabilized.
- Offset stability is the product's output deviation when subjected to 1000 hours of Pulsed Pressure, Temperature Cycling with Bias Test.
- Common mode pressures beyond what is specified may result in leakage at the case-to-lead interface.

MPX5050 SERIES

Figure 3 illustrates the Differential/Gauge Sensing Chip in the basic chip carrier (Case 867). A fluorosilicone gel isolates the die surface and wire bonds from the environment, while allowing the pressure signal to be transmitted to the sensor diaphragm.

The MPX5050 series pressure sensor operating characteristics, and internal reliability and qualification tests are based on use of dry air as the pressure media. Media, other than dry air, may have adverse effects on sensor performance and long-term reliability. Contact the factory for in-

formation regarding media compatibility in your application.

Figure 4 shows a typical decoupling circuit for interfacing the integrated sensor to the A/D input of a microprocessor. Proper decoupling of the power supply is recommended.

Figure 2 shows the sensor output signal relative to pressure input. Typical, minimum, and maximum output curves are shown for operation over a temperature range of 0° to 85°C using the decoupling circuit below. (The output will saturate outside of the specified pressure range.)

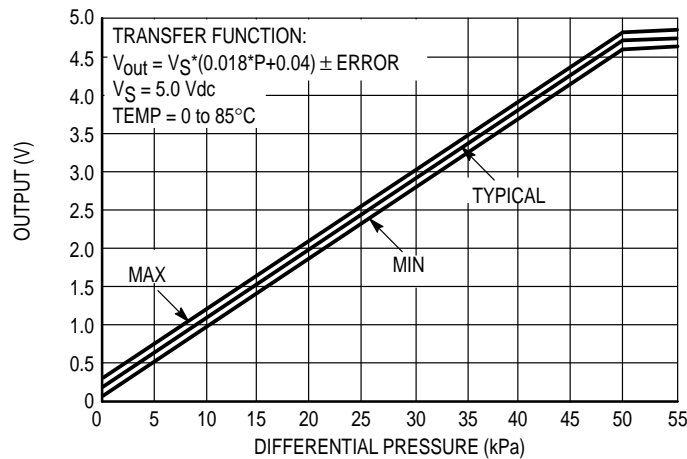

Figure 2. Output versus Pressure Differential

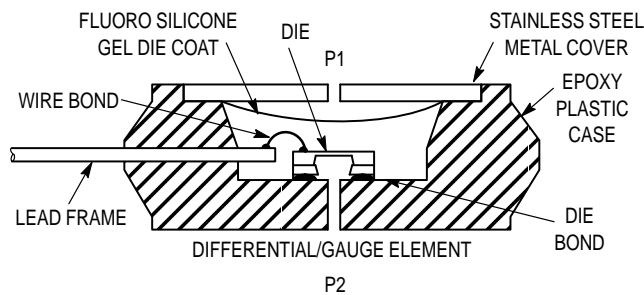

Figure 3. Cross-Sectional Diagram (Not to Scale)

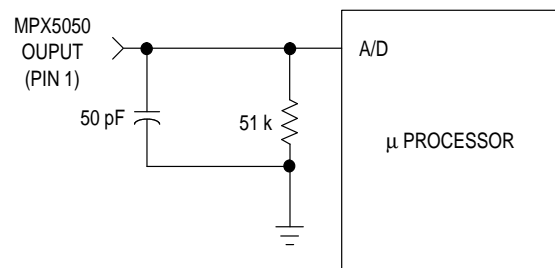

Figure 4. Typical Decoupling Filter for Sensor to Microprocessor Interface

MPX5050 SERIES

Transfer Function

Nominal Transfer Value: $V_{out} = V_S (P \times 0.018 + 0.04)$
 $\pm (\text{Pressure Error} \times \text{Temp. Factor} \times 0.018 \times V_S)$
 $V_S = 5.0 \text{ V} \pm 0.25 \text{ Vdc}$

Temperature Error Band

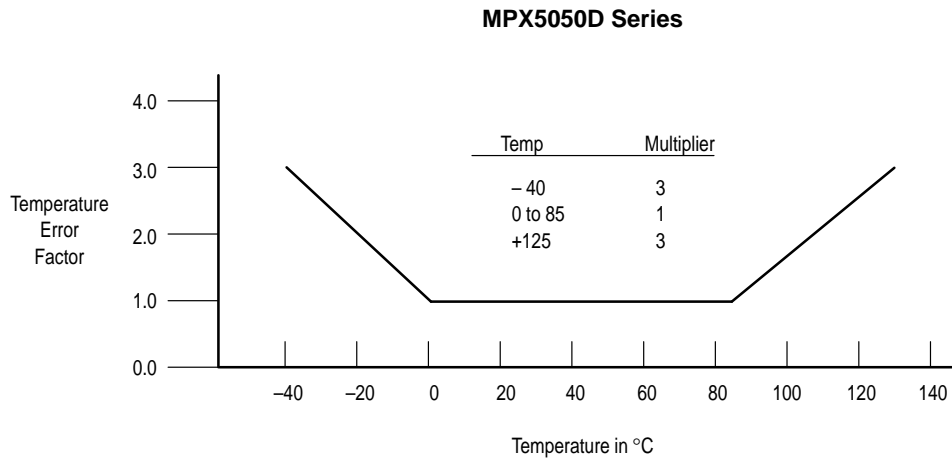

NOTE: The Temperature Multiplier is a linear response from 0° to -40°C and from 85° to 125°C.

Pressure Error Band

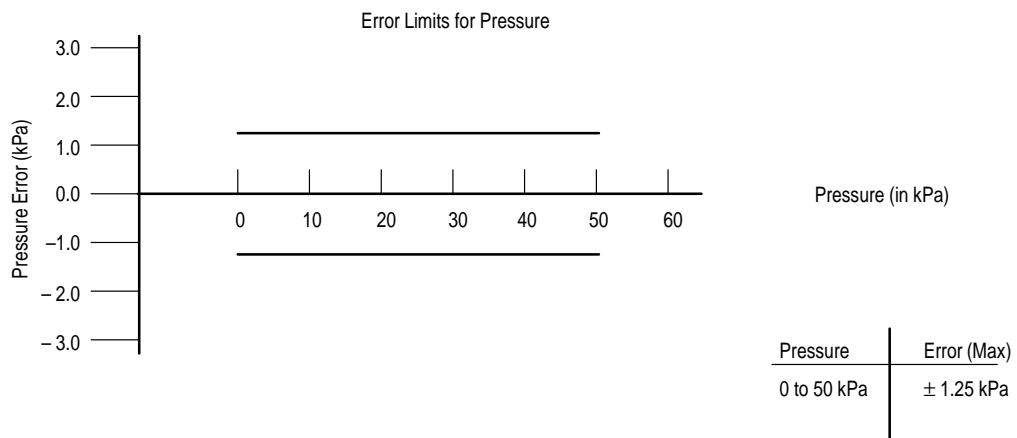

MPX5050 SERIES

PRESSURE (P1) / VACUUM (P2) SIDE IDENTIFICATION TABLE

Motorola designates the two sides of the pressure sensor as the Pressure (P1) side and the Vacuum (P2) side. The Pressure (P1) side is the side containing fluorosilicone gel which protects the die from harsh media. The Motorola MPX

pressure sensor is designed to operate with positive differential pressure applied, $P1 > P2$.

The Pressure (P1) side may be identified by using the table below:

Part Number	Case Type	Pressure (P1) Side Identifier
MPX5050D	867-08	Stainless Steel Cap
MPX5050DP	867C-05	Side with Part Marking
MPX5050GP	867B-04	Side with Port Attached
MPX5050GVP	867D-04	Stainless Steel Cap
MPX5050GS	867E-03	Side with Port Attached
MPX5050GVS	867A-04	Stainless Steel Cap
MPX5050GSX	867F-03	Side with Port Attached
MPX5050GVSX	867G-03	Stainless Steel Cap

ORDERING INFORMATION

The MPX5050 pressure sensor is available in differential and gauge configurations. Devices are available in the basic element package or with pressure port fittings that provide printed circuit board mounting ease and barbed hose pressure connections.

Device Type	Options	Case Type	MPX Series	
			Order Number	Device Marking
Basic Element	Differential	867-08	MPX5050D	MPX5050D
Ported Elements	Differential Dual Ports	867C-05	MPX5050DP	MPX5050DP
	Gauge	867B-04	MPX5050GP	MPX5050GP
	Gauge Vacuum Port	867D-04	MPX5050GVP	MPX5050GVP
	Gauge, Axial	867E-03	MPX5050GS	MPX5050D
	Gauge Vacuum Axial	867A-04	MPX5050GVS	MPX5050D
	Gauge, Axial PC Mount	867F-03	MPX5050GSX	MPX5050D
	Gauge Vacuum Axial PC Mount	867G-03	MPX5050GVSX	MPX5050D

MPX5050 SERIES

PACKAGE DIMENSIONS

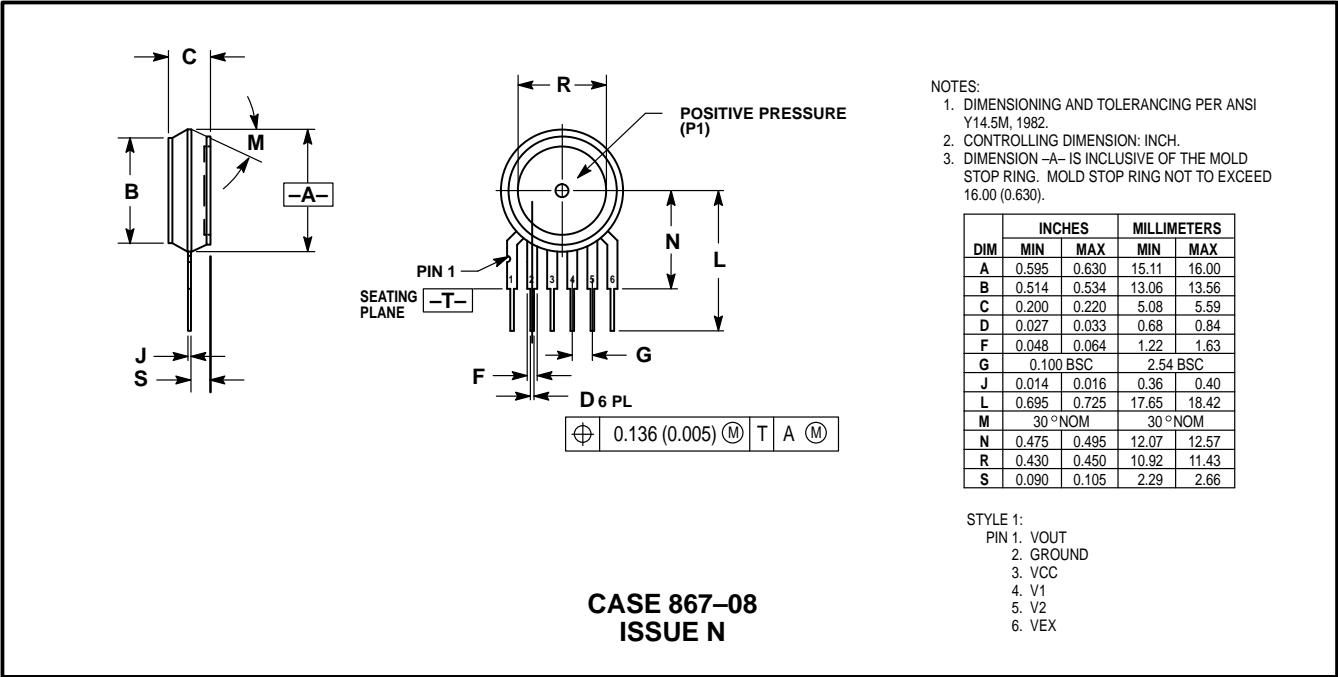

BASIC ELEMENT (D)

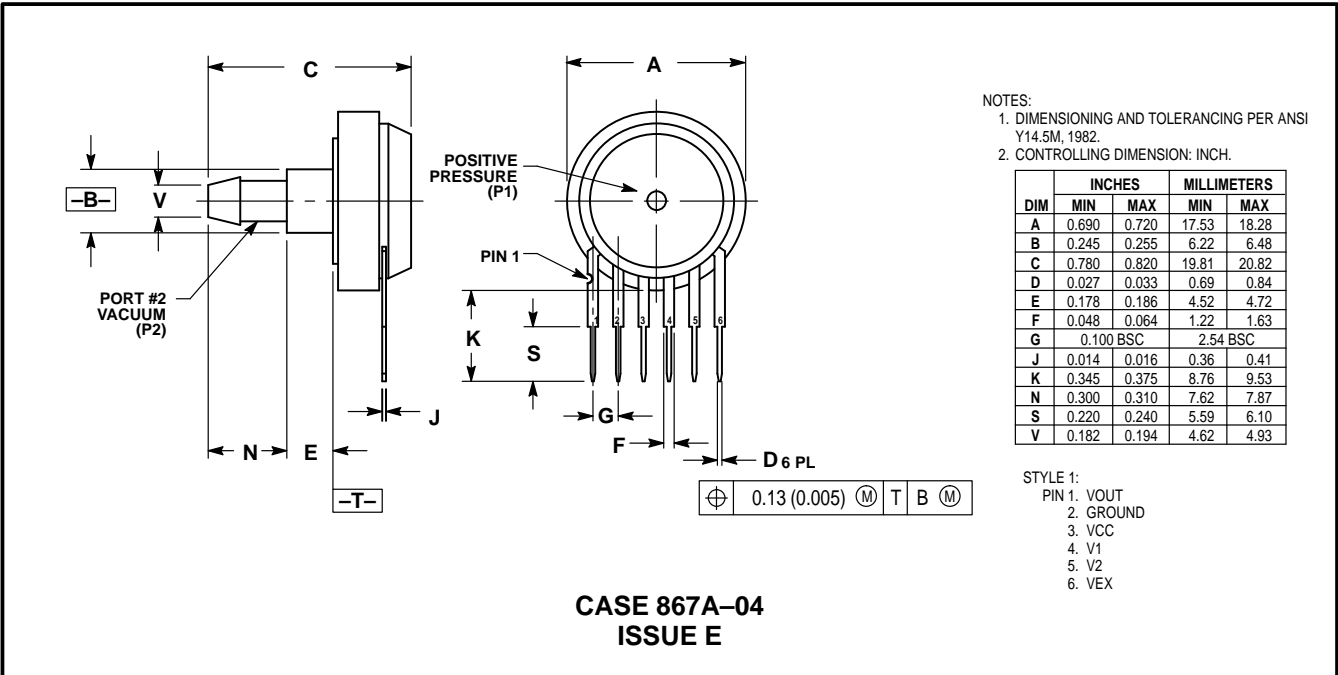

VACUUM SIDE PORTED (GVS)

PACKAGE DIMENSIONS—CONTINUED

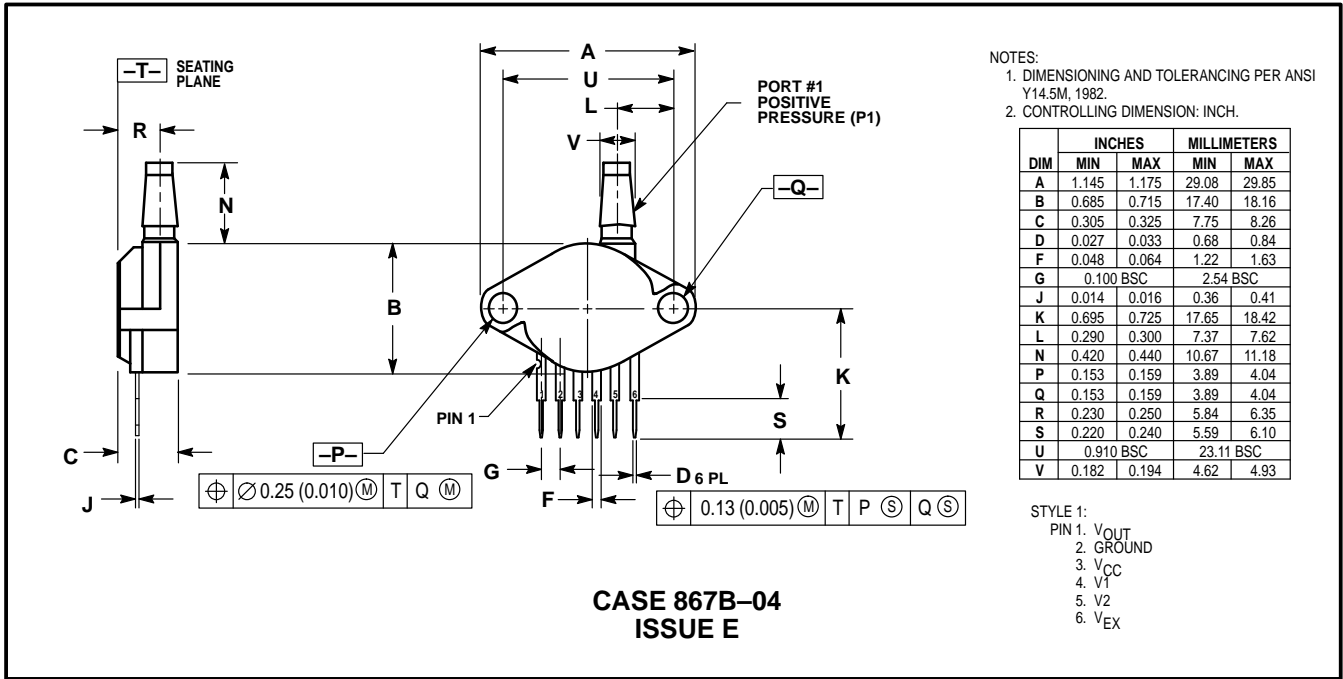

PRESSURE SIDE PORTED (GP)

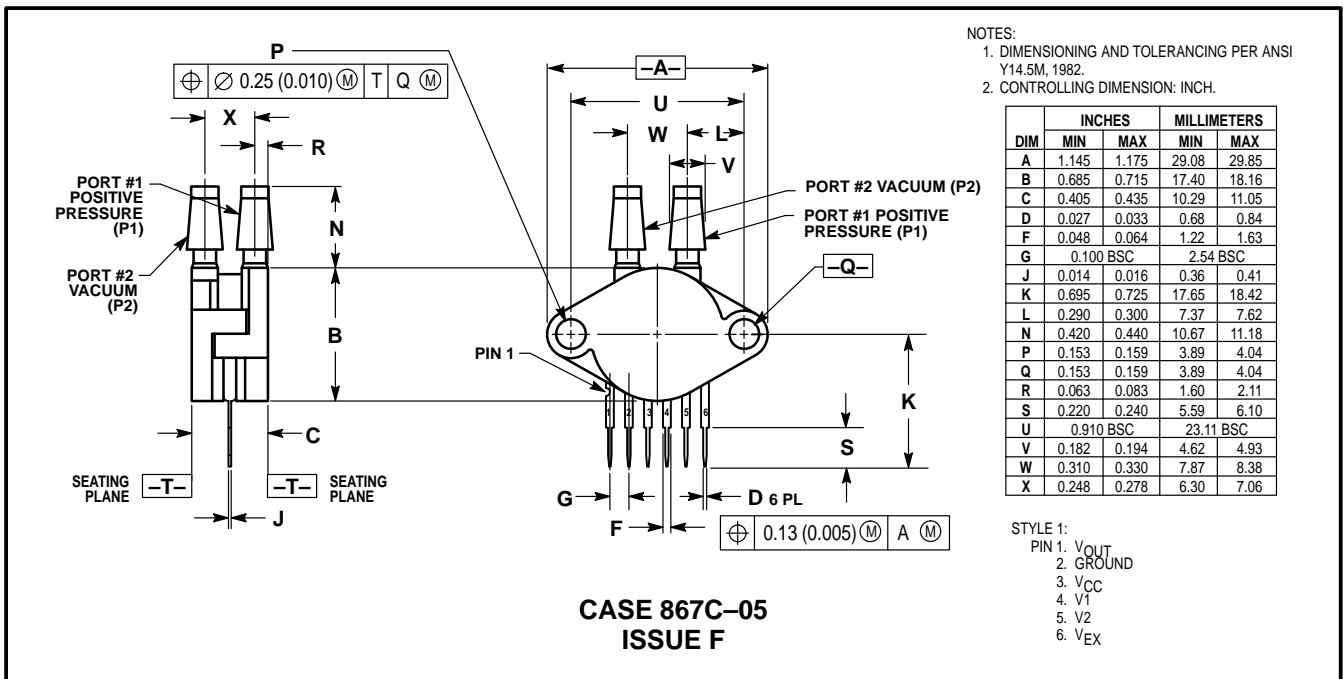

PRESSURE AND VACUUM SIDES PORTED (DP)

MPX5050 SERIES

PACKAGE DIMENSIONS—CONTINUED

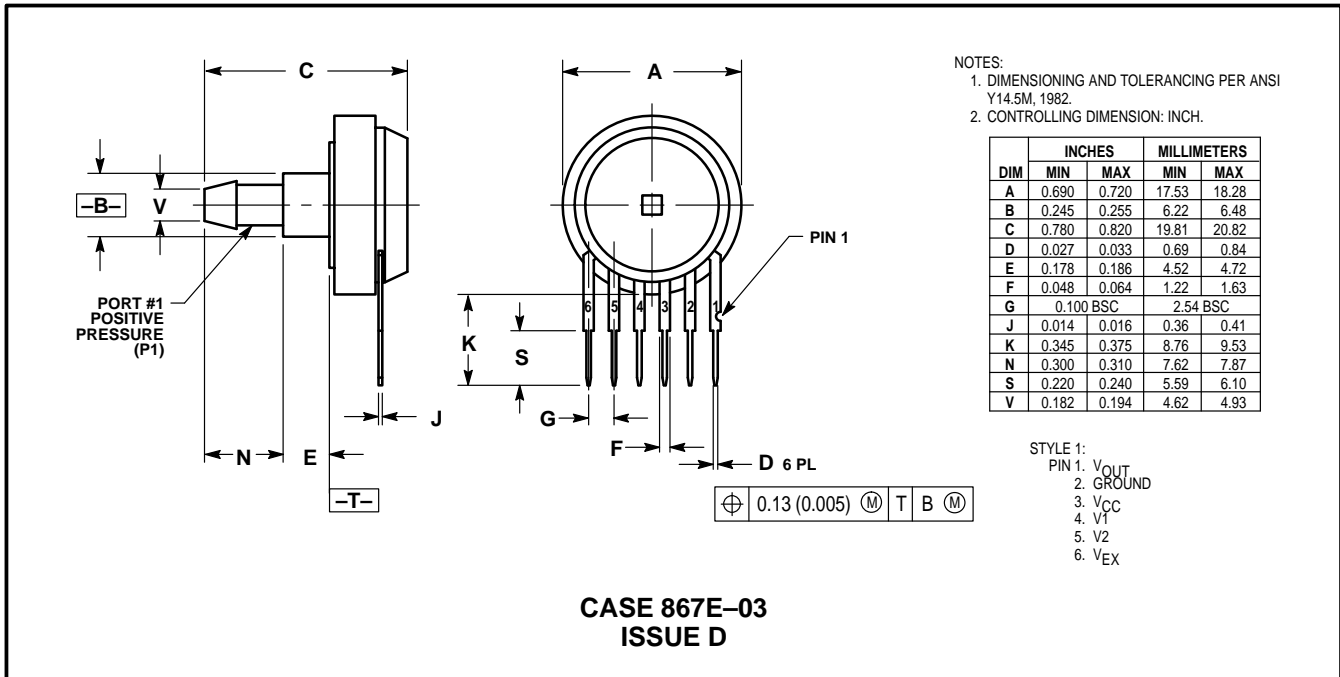
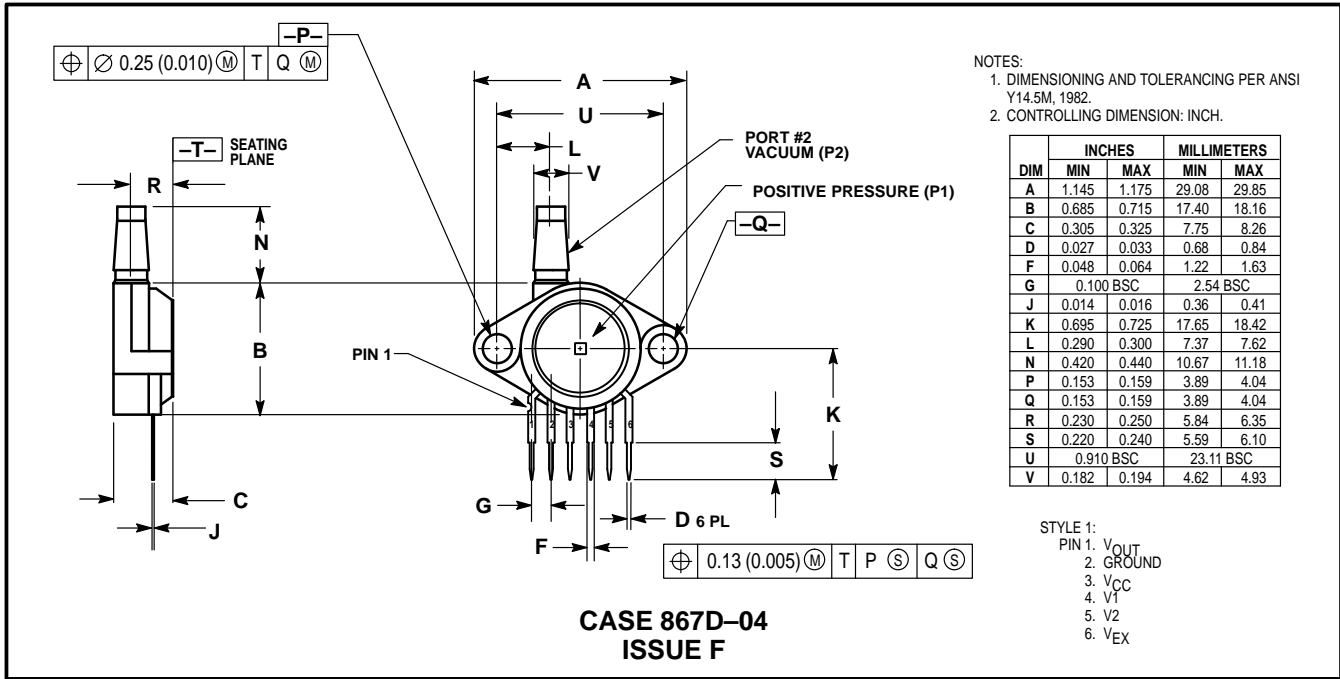

PACKAGE DIMENSIONS—CONTINUED

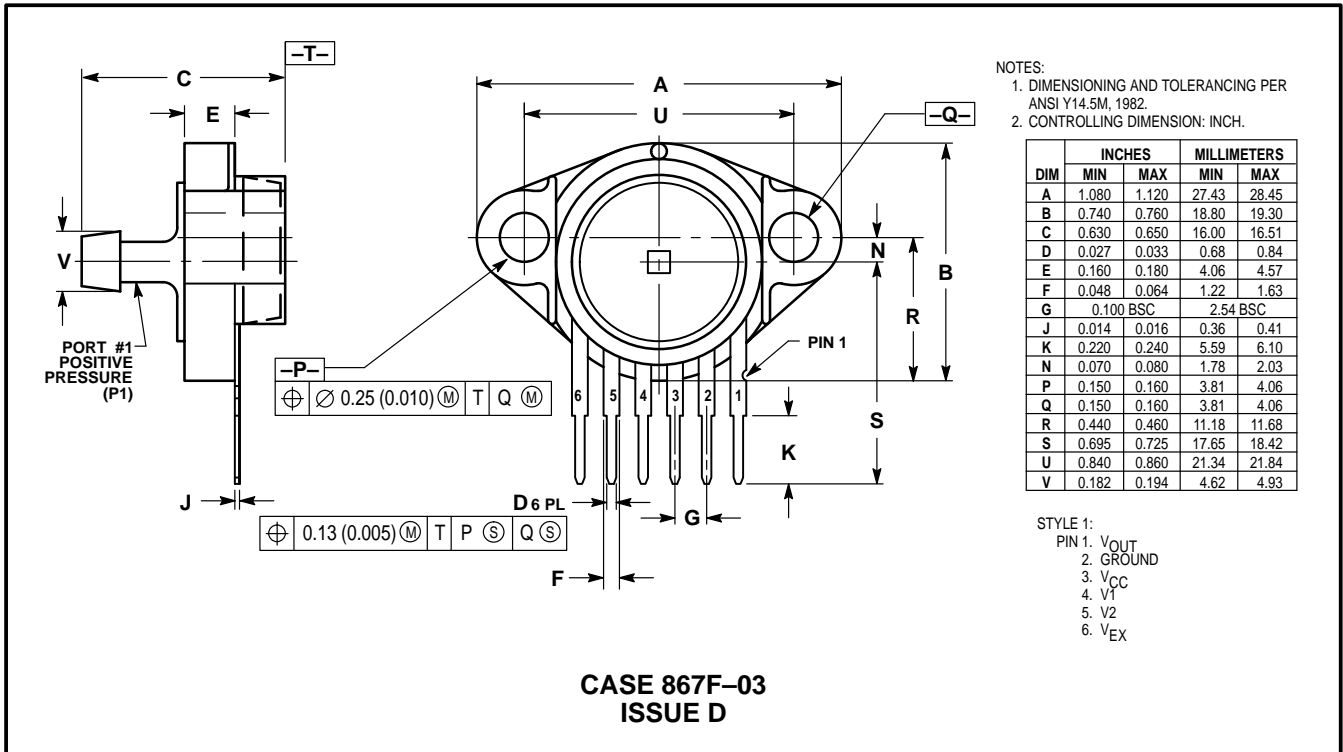

PRESSURE SIDE PORTED (GSX)

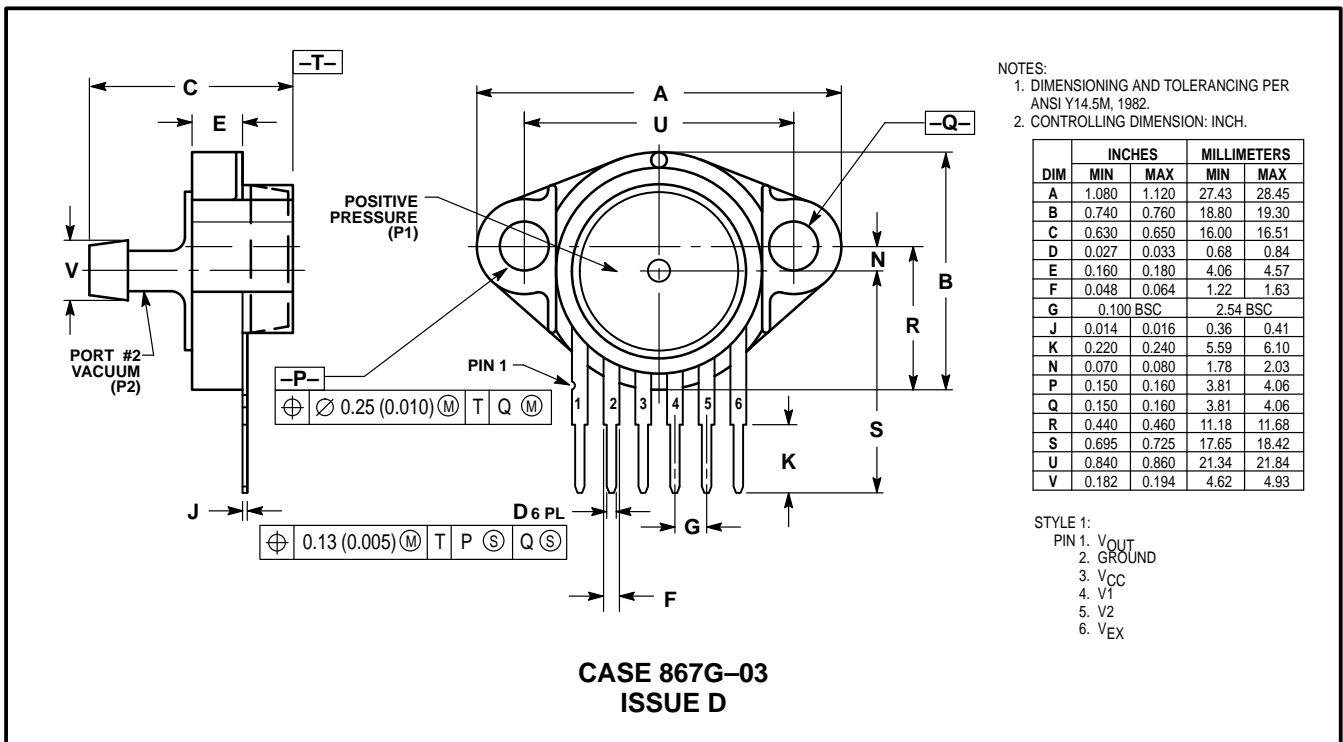

VACUUM SIDE PORTED (GV SX)

MPX5050 SERIES

Motorola reserves the right to make changes without further notice to any products herein. Motorola makes no warranty, representation or guarantee regarding the suitability of its products for any particular purpose, nor does Motorola assume any liability arising out of the application or use of any product or circuit, and specifically disclaims any and all liability, including without limitation consequential or incidental damages. "Typical" parameters which may be provided in Motorola data sheets and/or specifications can and do vary in different applications and actual performance may vary over time. All operating parameters, including "Typicals" must be validated for each customer application by customer's technical experts. Motorola does not convey any license under its patent rights nor the rights of others. Motorola products are not designed, intended, or authorized for use as components in systems intended for surgical implant into the body, or other applications intended to support or sustain life, or for any other application in which the failure of the Motorola product could create a situation where personal injury or death may occur. Should Buyer purchase or use Motorola products for any such unintended or unauthorized application, Buyer shall indemnify and hold Motorola and its officers, employees, subsidiaries, affiliates, and distributors harmless against all claims, costs, damages, and expenses, and reasonable attorney fees arising out of, directly or indirectly, any claim of personal injury or death associated with such unintended or unauthorized use, even if such claim alleges that Motorola was negligent regarding the design or manufacture of the part. Motorola and  are registered trademarks of Motorola, Inc. Motorola, Inc. is an Equal Opportunity/Affirmative Action Employer.

Mfax is a trademark of Motorola, Inc.

How to reach us:

USA/EUROPE/Locations Not Listed: Motorola Literature Distribution;
P.O. Box 5405, Denver, Colorado 80217. 303-675-2140 or 1-800-441-2447

JAPAN: Nippon Motorola Ltd.; Tatsumi-SPD-JLDC, 6F Seibu-Butsuryu-Center,
3-14-2 Tatsumi Koto-Ku, Tokyo 135, Japan. 81-3-3521-8315

Mfax™: RMFAX0@email.sps.mot.com – TOUCHSTONE 602-244-6609
– US & Canada ONLY 1-800-774-1848

ASIA/PACIFIC: Motorola Semiconductors H.K. Ltd.; 8B Tai Ping Industrial Park,
51 Ting Kok Road, Tai Po, N.T., Hong Kong. 852-26629298

INTERNET: <http://motorola.com/sps>

