

TOSHIBA

GT15G101

TOSHIBA INSULATED GATE BIPOlar TRANSISTOR SILICON N-CHANNEL IGBT

GT15G101

STROBE FLASH APPLICATIONS

- High Input Impedance
- Low Saturation Voltage : $V_{CE(sat)}=8V$ (Max.) ($I_C=170A$)
- Enhancement-Mode
- 20V Gate Drive

MAXIMUM RATINGS ($T_a = 25^\circ C$)

CHARACTERISTIC		SYMBOL	RATING	UNIT
Collector-Emitter Voltage		V_{CES}	400	V
Gate-Emitter Voltage		V_{GES}	± 25	V
Collector Current	DC	I_C	15	A
	1ms	I_{CP}	170	
Collector Power Dissipation	$T_a = 25^\circ C$	P_C	2.0	W
	$T_c = 25^\circ C$	P_C	40	
Junction Temperature		T_j	150	$^\circ C$
Storage Temperature Range		T_{stg}	-55~150	$^\circ C$
Screw Torque		—	0.6	N·m

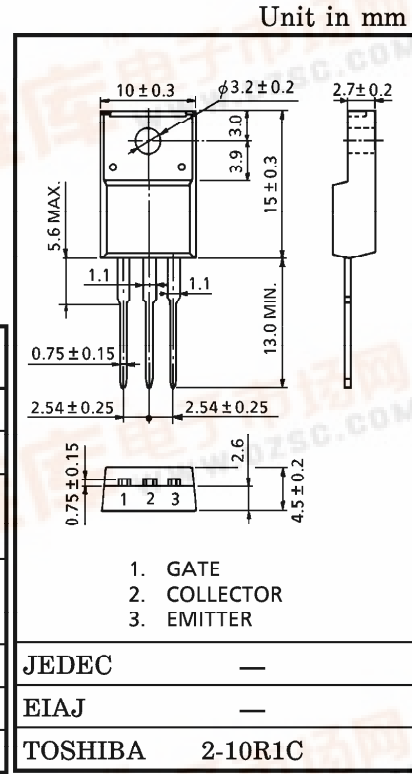

ELECTRICAL CHARACTERISTICS ($T_a = 25^\circ C$)

CHARACTERISTIC		SYMBOL	TEST CONDITION	MIN.	TYP.	MAX.	UNIT
Gate Leakage Current		I_{GES}	$V_{GE} = \pm 25V, V_{CE} = 0$	—	—	± 100	nA
Collector Cut-off Current		I_{CES}	$V_{CE} = 400V, V_{GE} = 0$	—	—	10	μA
Gate-Emitter Cut-off Voltage		$V_{GE(OFF)}$	$I_C = 1mA, V_{CE} = 5V$	4	5	7	V
Collector-Emitter Saturation Voltage		$V_{CE(sat)}$	$I_C = 170A, V_{GE} = 20V$ (Pulsed)	—	5	8	V
Input Capacitance		C_{ies}	$V_{CE} = 10V, V_{GE} = 0, f = 1MHz$	—	2000	—	pF
Switching Time	Rise Time	t_r	 $V_{IN} : t_r \leq 100ns$ $t_f \leq 100ns$ Duty cycle $\leq 1\%$	—	0.1	0.5	μs
	Turn-on Time	t_{on}		—	0.15	0.5	
	Fall Time	t_f		—	4.0	6.0	
	Turn-off Time	t_{off}		—	4.5	7.0	
Thermal Resistance		$R_{th(j-c)}$	—	—	—	3.12	$^\circ C/W$

961001EAA2

● TOSHIBA is continually working to improve the quality and the reliability of its products. Nevertheless, semiconductor devices in general can malfunction or fail due to their inherent electrical sensitivity and vulnerability to physical stress. It is the responsibility of the buyer, when utilizing TOSHIBA products, to observe standards of safety, and to avoid situations in which a malfunction or failure of a TOSHIBA product could cause loss of human life, bodily injury or damage to property. In developing your designs, please ensure that TOSHIBA products are used within specified operating ranges as set forth in the most recent products specifications. Also, please keep in mind the precautions and conditions set forth in the TOSHIBA Semiconductor Reliability Handbook.

● The information contained herein is presented only as a guide for the applications of our products. No responsibility is assumed by TOSHIBA CORPORATION for any infringements of intellectual property or other rights of the third parties which may result from its use. No license is granted by implication or otherwise under any intellectual property or other rights of TOSHIBA CORPORATION or others.

● The information contained herein is subject to change without notice.



