

INTEGRATED CIRCUITS

DATA SHEET

74HC1GU04 Inverter

Product specification
File under Integrated Circuits, IC06

1998 Nov 18

Inverter

74HC1GU04

FEATURES

- Wide operating voltage: 2.0 to 6.0 V
- Symmetrical output impedance
- Low power dissipation
- Balanced propagation delays
- Very small 5-pin package
- Output capability: standard.

DESCRIPTION

The 74HC1GU04 is a high-speed Si-gate CMOS device.

The 74HC1GU04 provides the inverting single stage function. The standard output currents are $\frac{1}{2}$ compared to the 74HCU04.

FUNCTION TABLE

See note 1.

INPUT inA	OUTPUT outY
L	H
H	L

Note

1. H = HIGH voltage level;
L = LOW voltage level.

QUICK REFERENCE DATA

GND = 0 V; $T_{amb} = 25\text{ }^{\circ}\text{C}$; $t_r = t_f = 6.0\text{ ns}$.

SYMBOL	PARAMETER	CONDITIONS	TYP.	UNIT
t_{PHL}/t_{PLH}	propagation delay inA to outY	$C_L = 15\text{ pF}$; $V_{CC} = 5\text{ V}$	5	ns
C_I	input capacitance		5	pF
C_{PD}	power dissipation capacitance	notes 1 and 2	14	pF

Notes

1. C_{PD} is used to determine the dynamic power dissipation (P_D in μW).
 $P_D = C_{PD} \times V_{CC}^2 \times f_i + \sum (C_L \times V_{CC}^2 \times f_o)$ where:
 f_i = input frequency in MHz;
 f_o = output frequency in MHz;
 C_L = output load capacitance in pF;
 V_{CC} = supply voltage in V;
 $\sum (C_L \times V_{CC}^2 \times f_o)$ = sum of outputs.
2. For HC1G the condition is $V_I = \text{GND}$ to V_{CC} .

PINNING

PIN	SYMBOL	DESCRIPTION
1	n.c.	not connected
2	inA	data input
3	GND	ground (0 V)
4	outY	data output
5	V_{CC}	DC supply voltage

Inverter

74HC1GU04

ORDERING INFORMATION

OUTSIDE NORTH AMERICA	PACKAGES					
	TEMPERATURE RANGE	PINS	PACKAGE	MATERIAL	CODE	MARKING
74HC1GU04GW	-40 to +125 °C	5	SC-88A	plastic	SOT353	HD

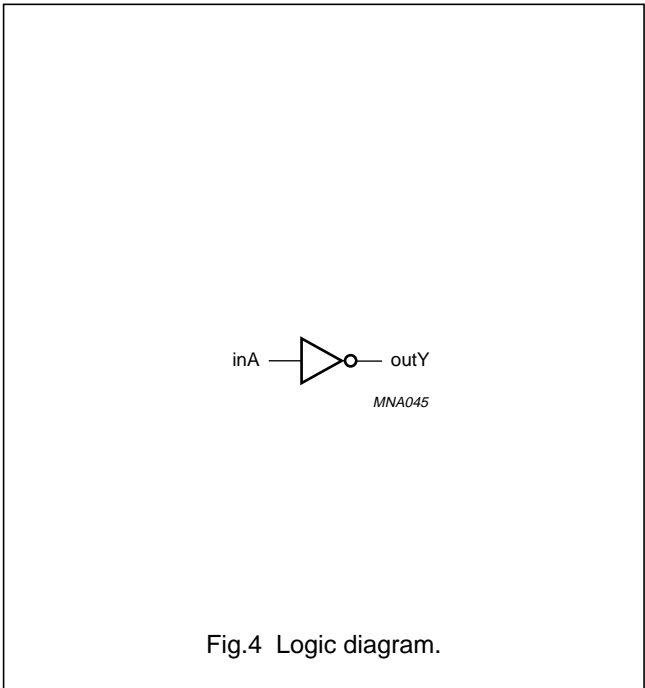
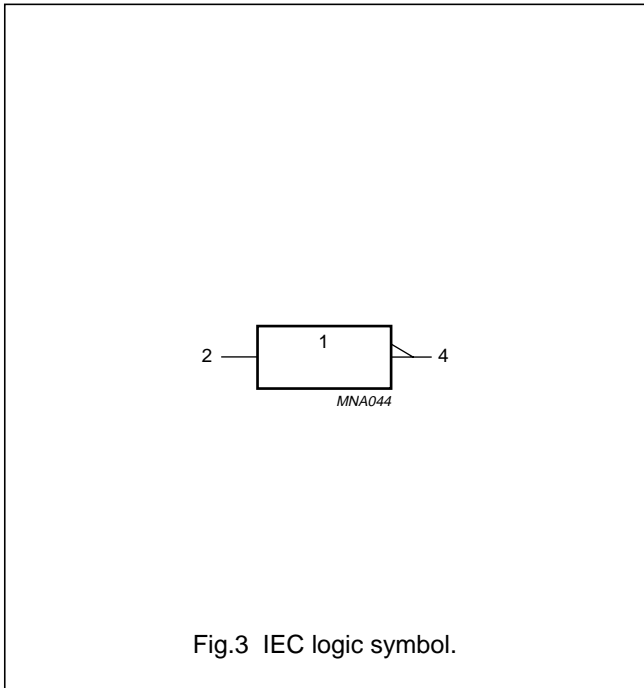
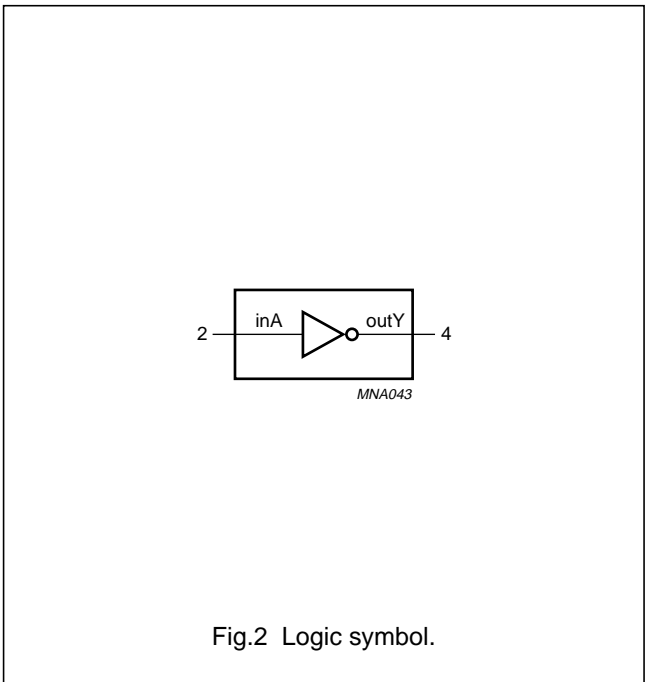
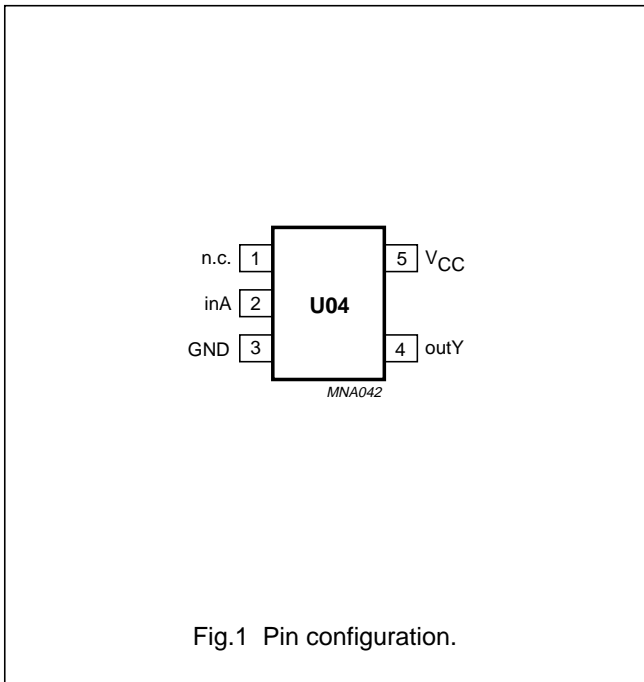

Inverter

74HC1GU04

RECOMMENDED OPERATING CONDITIONS

SYMBOL	PARAMETER	CONDITIONS	74HC1G			UNIT
			MIN.	TYP.	MAX.	
V_{CC}	DC supply voltage		2.0	5.0	6.0	V
V_I	input voltage		0	–	V_{CC}	V
V_O	output voltage		0	–	V_{CC}	V
T_{amb}	operating ambient temperature range	see DC and AC characteristics per device	–40	+25	+125	°C
t_r, t_f	input rise and fall times except for Schmitt-trigger inputs	$V_{CC} = 2.0\text{ V}$	–	–	1000	ns
		$V_{CC} = 4.5\text{ V}$	–	–	500	ns
		$V_{CC} = 6.0\text{ V}$	–	–	400	ns

LIMITING VALUES

In accordance with the Absolute Maximum Rating System (IEC 134). Voltages are referenced to GND (ground = 0 V).

SYMBOL	PARAMETER	CONDITIONS	MIN.	MAX.	UNIT
V_{CC}	DC supply voltage		–0.5	+7.0	V
$\pm I_{IK}$	DC input diode current ⁽¹⁾	$V_I < -0.5$ or $V_I > V_{CC} + 0.5\text{ V}$	–	20	mA
$\pm I_{OK}$	DC output diode current ⁽¹⁾	$V_O < -0.5$ or $V_O > V_{CC} + 0.5\text{ V}$	–	20	mA
$\pm I_O$	DC output source or sink current standard outputs ⁽¹⁾	$-0.5\text{ V} < V_O < V_{CC} + 0.5\text{ V}$	–	12.5	mA
$\pm I_{CC}$	DC V_{CC} or GND current for types with standard outputs ⁽¹⁾		–	25	mA
T_{stg}	storage temperature range		–65	+150	°C
P_D	power dissipation per package 5 pins plastic SC-88A	for temperature range: –40 to +125 °C; above +55 °C P_D derates linearly with 2.5 mW/K	–	200	mW

Note

1. The input and output voltage ratings may be exceeded if the input and output current ratings are observed.

Inverter

74HC1GU04

DC CHARACTERISTICS FOR THE 74HC1GU04

Over recommended operating conditions. Voltage are referenced to GND (ground = 0 V).

SYMBOL	PARAMETER	TEST CONDITIONS		T_{amb} (°C)					UNIT
		OTHER	V_{CC} (V)	-40 to +85			-40 to +125		
				MIN.	TYP. ⁽¹⁾	MAX.	MIN.	MAX.	
V_{IH}	HIGH-level input voltage		2.0	1.7	1.4	–	1.7	–	V
			4.5	3.6	2.6	–	3.6	–	V
			6.0	4.8	3.4	–	4.8	–	V
V_{IL}	LOW-level input voltage		2.0	–	0.6	0.3	–	0.3	V
			4.5	–	1.9	0.9	–	0.9	V
			6.0	–	2.6	1.2	–	1.2	V
V_{OH}	HIGH-level output voltage; all outputs	$V_I = V_{IH}$ or V_{IL} , $-I_O = 20 \mu A$	2.0	1.8	2.0	–	1.8	–	V
			4.5	4.0	4.5	–	4.0	–	V
			6.0	5.5	6.0	–	5.5	–	V
V_{OH}	HIGH-level output voltage; standard outputs	$V_I = V_{IH}$ or V_{IL} , $-I_O = 2.0 \text{ mA}$	4.5	4.13	4.32	–	3.7	–	V
		$V_I = V_{IH}$ or V_{IL} , $-I_O = 2.6 \text{ mA}$	6.0	5.63	5.81	–	5.2	–	V
V_{OL}	LOW-level output voltage; all outputs	$V_I = V_{IH}$ or V_{IL} , $I_O = 20 \mu A$	2.0	–	0	0.2	–	0.2	V
			4.5	–	0	0.5	–	0.5	V
			6.0	–	0	0.5	–	0.5	V
V_{OL}	LOW-level output voltage; standard outputs	$V_I = V_{IH}$ or V_{IL} , $I_O = 2.0 \text{ mA}$	4.5	–	0.15	0.33	–	0.4	V
		$V_I = V_{IH}$ or V_{IL} , $I_O = 2.6 \text{ mA}$	6.0	–	0.16	0.33	–	0.4	V
I_I	input leakage current	$V_I = V_{CC}$ or GND	6.0	–	–	1.0	–	1.0	μA
I_{CC}	quiescent supply current	$V_I = V_{CC}$ or GND, $I_O = 0$	6.0	–	–	10	–	20	μA

Note1. All typical values are measured at $T_{amb} = 25 \text{ }^\circ\text{C}$.

Inverter

74HC1GU04

AC CHARACTERISTICS

GND = 0 V; $t_r = t_f = 6.0$ ns; $C_L = 50$ pF.

SYMBOL	PARAMETER	TEST CONDITIONS		T_{amb} (°C)					UNIT
		WAVEFORMS	V_{CC} (V)	-40 to +85			-40 to +125		
				MIN.	TYP. ⁽¹⁾	MAX.	MIN.	MAX.	
t_{PHL}/t_{PLH}	propagation delay inA to outY	see Figs 5 and 6	2.0	–	10	90	–	105	ns
			4.5	–	7	18	–	21	ns
			6.0	–	6	15	–	18	ns

Note

1. All typical values are measured at $T_{amb} = 25$ °C.

AC WAVEFORMS

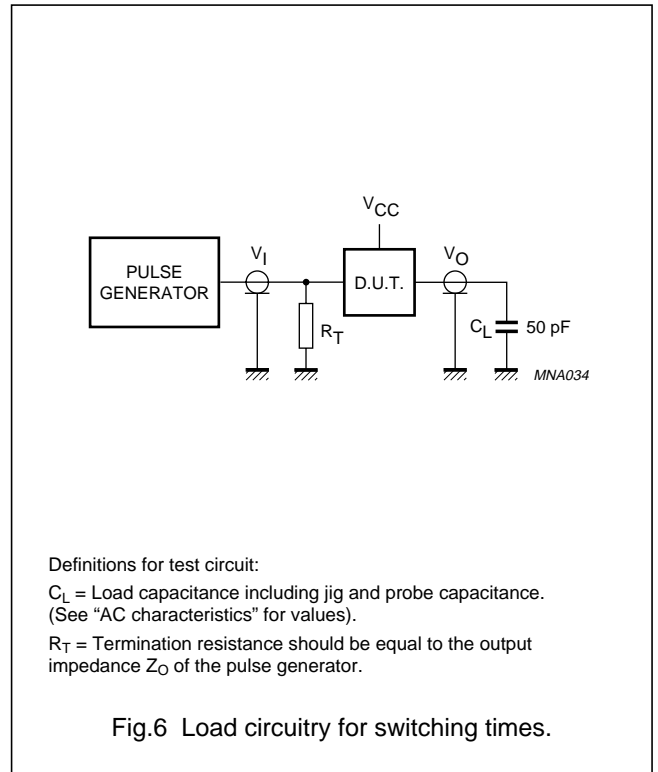
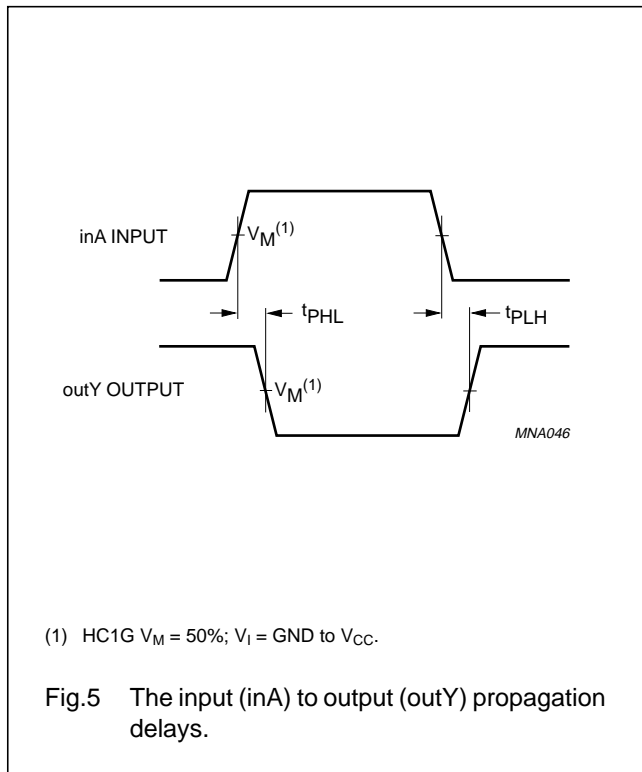

Inverter

74HC1GU04

TYPICAL TRANSFER CHARACTERISTICS

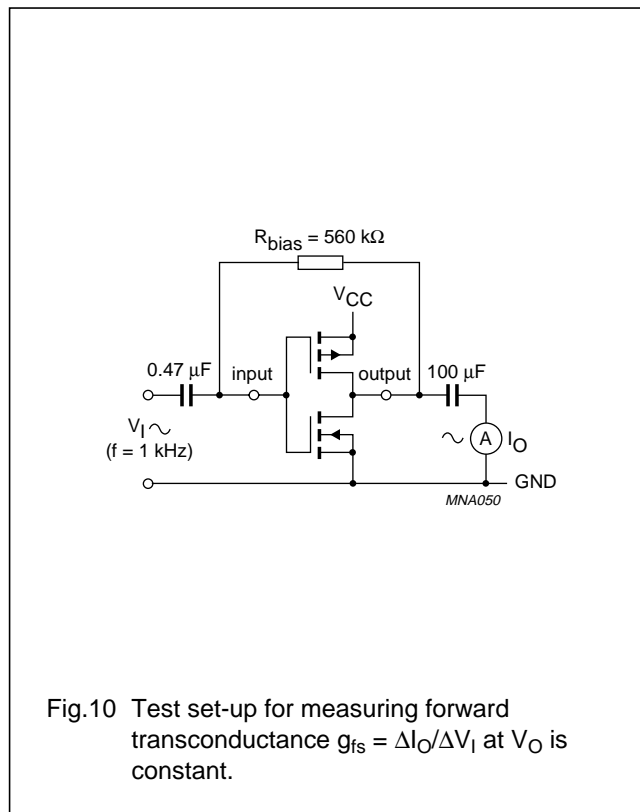
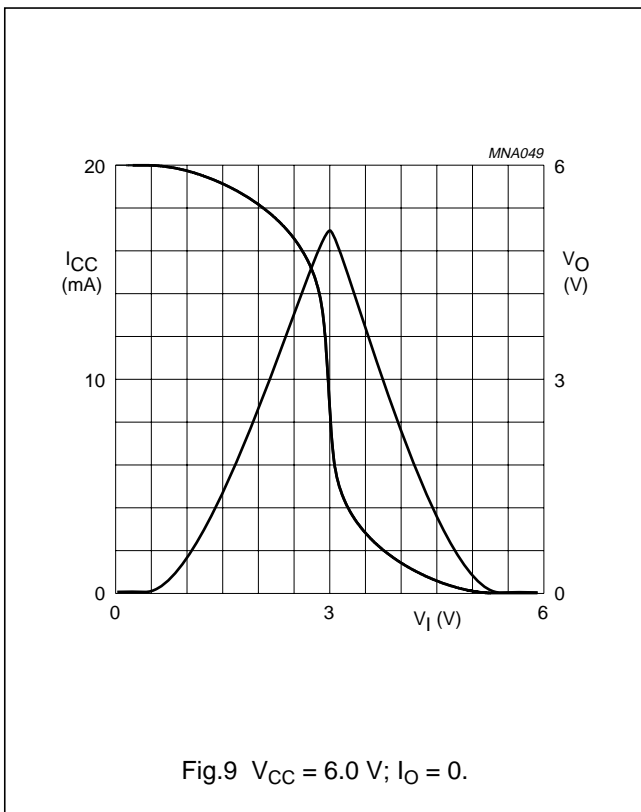
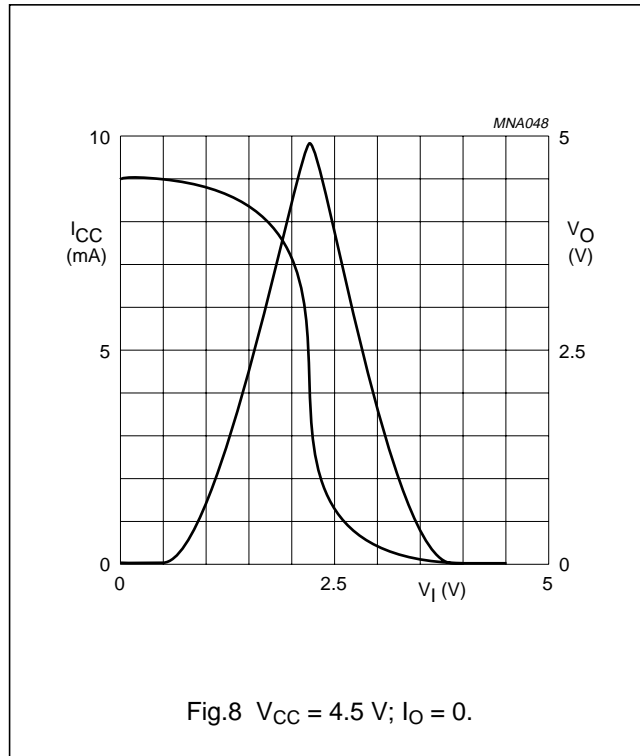
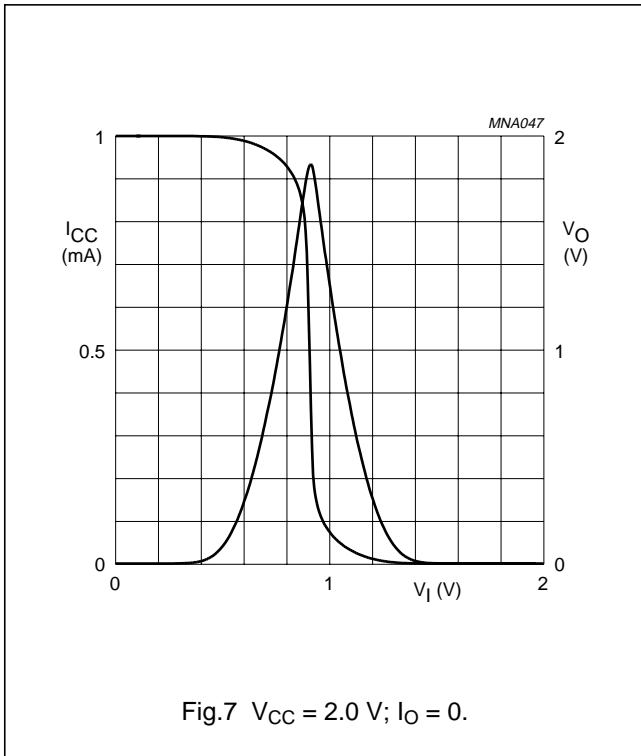

Inverter

74HC1GU04

APPLICATION INFORMATION

Some applications for the HC1GU04 are:

- Linear amplifier (see Fig.11)
- In crystal oscillator design (see Fig.12).

Note to the application information.

All values given are typical unless otherwise specified.

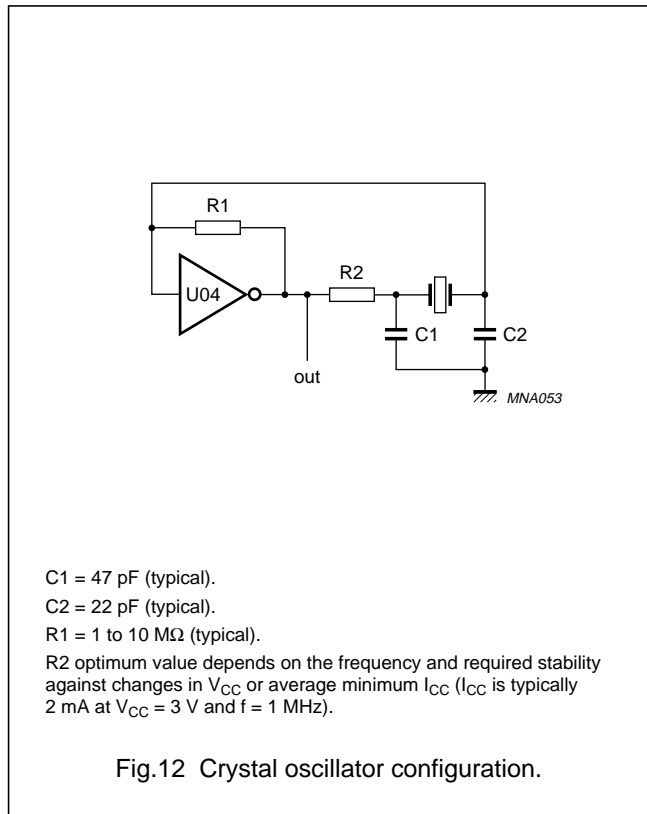
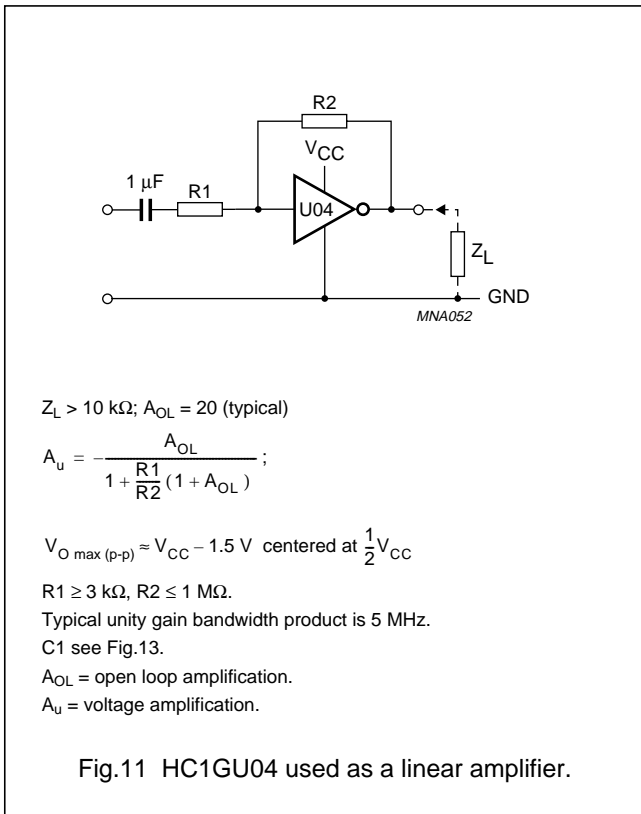

External components for resonator (f < 1 MHz)

FREQUENCY (kHz)	R1 (MΩ)	R2 (kΩ)	C1 (pF)	C2 (pF)
10 to 15.9	2.2	220	56	20
16 to 24.9	2.2	220	56	10
25 to 54.9	2.2	100	56	10
55 to 129.9	2.2	100	47	5
130 to 199.9	2.2	47	47	5
200 to 349.9	2.2	47	47	5
350 to 600	2.2	47	47	5

Where:

All values given are typical and must be used as an initial set-up.

Inverter

74HC1GU04

Optimum value for R2

FREQUENCY (kHz)	R2 (kΩ)	OPTIMUM FOR
3	2.0 8.0	minimum required I _{CC} minimum influence due to change in V _{CC}
6	1.0 4.7	minimum required I _{CC} minimum influence by V _{CC}
10	0.5 2.0	
14	0.5 1.0	
>14	replace R2 by C3 with a typical value of 35 pF	

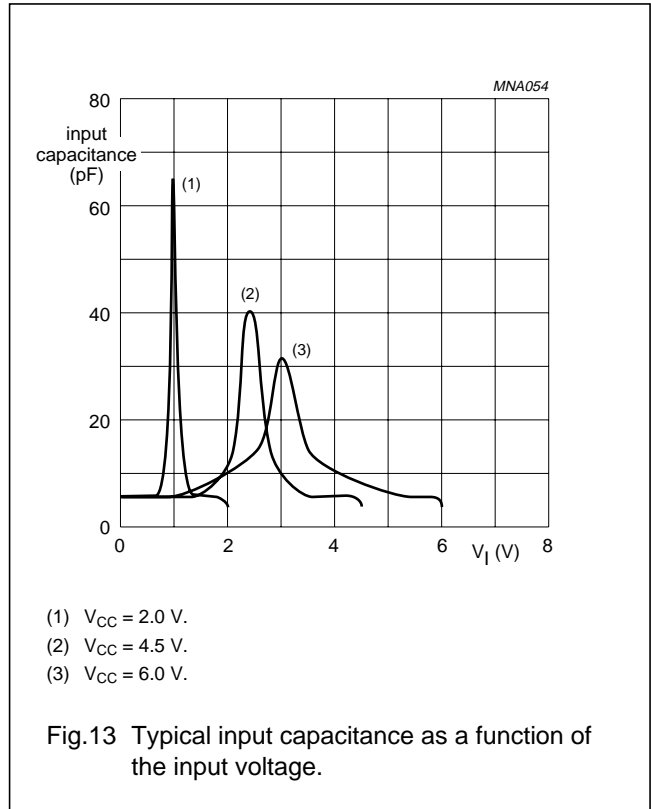

Inverter

74HC1GU04

PACKAGE OUTLINE

Plastic surface mounted package; 5 leads

SOT353

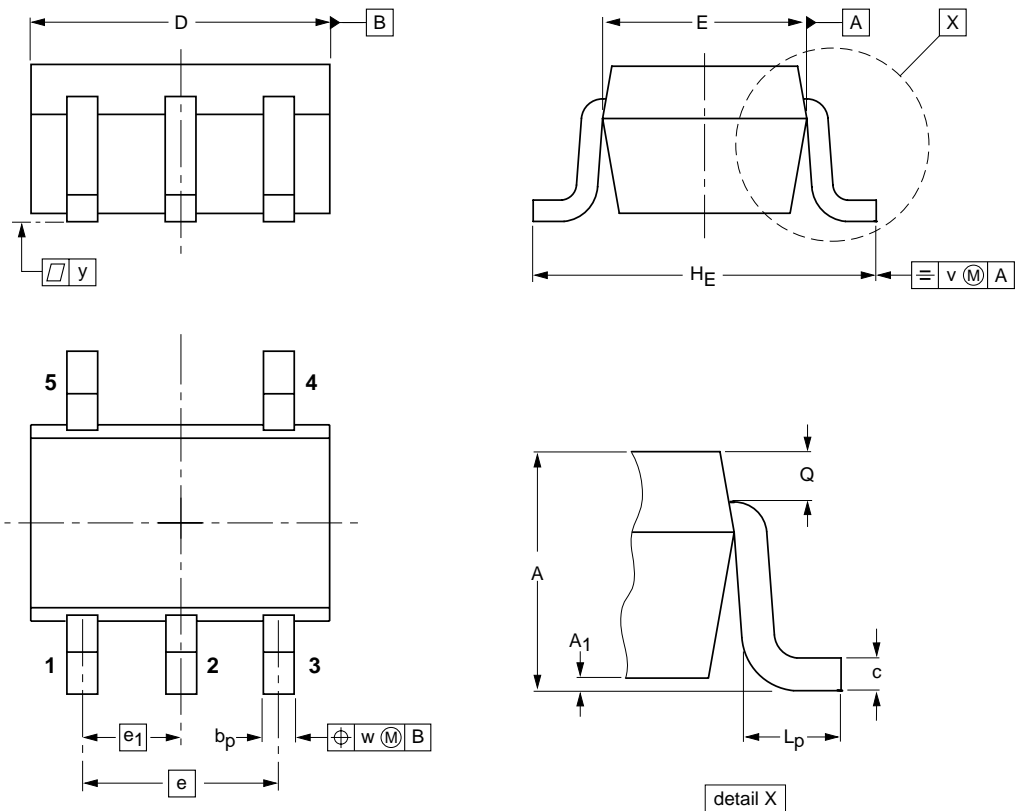

DIMENSIONS (mm are the original dimensions)

UNIT	A	A ₁ max	b _p	c	D	E ⁽²⁾	e	e ₁	H _E	L _p	Q	v	w	y
mm	1.1 0.8	0.1	0.30 0.20	0.25 0.10	2.2 1.8	1.35 1.15	1.3	0.65	2.2 2.0	0.45 0.15	0.25 0.15	0.2	0.2	0.1

OUTLINE VERSION	REFERENCES				EUROPEAN PROJECTION	ISSUE DATE
	IEC	JEDEC	EIAJ			
SOT353			SC-88A			97-02-28

Inverter

74HC1GU04

SOLDERING

Introduction to soldering surface mount packages

This text gives a very brief insight to a complex technology. A more in-depth account of soldering ICs can be found in our *"Data Handbook IC26; Integrated Circuit Packages"* (document order number 9398 652 90011).

There is no soldering method that is ideal for all surface mount IC packages. Wave soldering is not always suitable for surface mount ICs, or for printed-circuit boards with high population densities. In these situations reflow soldering is often used.

Reflow soldering

Reflow soldering requires solder paste (a suspension of fine solder particles, flux and binding agent) to be applied to the printed-circuit board by screen printing, stencilling or pressure-syringe dispensing before package placement.

Several methods exist for reflowing; for example, infrared/convection heating in a conveyor type oven. Throughput times (preheating, soldering and cooling) vary between 100 and 200 seconds depending on heating method.

Typical reflow peak temperatures range from 215 to 250 °C. The top-surface temperature of the packages should preferably be kept below 230 °C.

Wave soldering

Conventional single wave soldering is not recommended for surface mount devices (SMDs) or printed-circuit boards with a high component density, as solder bridging and non-wetting can present major problems.

To overcome these problems the double-wave soldering method was specifically developed.

If wave soldering is used the following conditions must be observed for optimal results:

- Use a double-wave soldering method comprising a turbulent wave with high upward pressure followed by a smooth laminar wave.
- For packages with leads on two sides and a pitch (e):
 - larger than or equal to 1.27 mm, the footprint longitudinal axis is **preferred** to be parallel to the transport direction of the printed-circuit board;
 - smaller than 1.27 mm, the footprint longitudinal axis **must** be parallel to the transport direction of the printed-circuit board.

The footprint must incorporate solder thieves at the downstream end.

- For packages with leads on four sides, the footprint must be placed at a 45° angle to the transport direction of the printed-circuit board. The footprint must incorporate solder thieves downstream and at the side corners.

During placement and before soldering, the package must be fixed with a droplet of adhesive. The adhesive can be applied by screen printing, pin transfer or syringe dispensing. The package can be soldered after the adhesive is cured.

Typical dwell time is 4 seconds at 250 °C.

A mildly-activated flux will eliminate the need for removal of corrosive residues in most applications.

Manual soldering

Fix the component by first soldering two diagonally-opposite end leads. Use a low voltage (24 V or less) soldering iron applied to the flat part of the lead. Contact time must be limited to 10 seconds at up to 300 °C.

When using a dedicated tool, all other leads can be soldered in one operation within 2 to 5 seconds between 270 and 320 °C.

Inverter

74HC1GU04

Suitability of surface mount IC packages for wave and reflow soldering methods

PACKAGE	SOLDERING METHOD	
	WAVE	REFLOW ⁽¹⁾
BGA, SQFP	not suitable	suitable
HLQFP, HSQFP, HSOP, SMS	not suitable ⁽²⁾	suitable
PLCC ⁽³⁾ , SO, SOJ	suitable	suitable
LQFP, QFP, TQFP	not recommended ⁽³⁾⁽⁴⁾	suitable
SSOP, TSSOP, VSO	not recommended ⁽⁵⁾	suitable

Notes

1. All surface mount (SMD) packages are moisture sensitive. Depending upon the moisture content, the maximum temperature (with respect to time) and body size of the package, there is a risk that internal or external package cracks may occur due to vaporization of the moisture in them (the so called popcorn effect). For details, refer to the Drypack information in the "Data Handbook IC26; Integrated Circuit Packages; Section: Packing Methods".
2. These packages are not suitable for wave soldering as a solder joint between the printed-circuit board and heatsink (at bottom version) can not be achieved, and as solder may stick to the heatsink (on top version).
3. If wave soldering is considered, then the package must be placed at a 45° angle to the solder wave direction. The package footprint must incorporate solder thieves downstream and at the side corners.
4. Wave soldering is only suitable for LQFP, TQFP and QFP packages with a pitch (e) equal to or larger than 0.8 mm; it is definitely not suitable for packages with a pitch (e) equal to or smaller than 0.65 mm.
5. Wave soldering is only suitable for SSOP and TSSOP packages with a pitch (e) equal to or larger than 0.65 mm; it is definitely not suitable for packages with a pitch (e) equal to or smaller than 0.5 mm.

DEFINITIONS

Data sheet status	
Objective specification	This data sheet contains target or goal specifications for product development.
Preliminary specification	This data sheet contains preliminary data; supplementary data may be published later.
Product specification	This data sheet contains final product specifications.
Limiting values	
Limiting values given are in accordance with the Absolute Maximum Rating System (IEC 134). Stress above one or more of the limiting values may cause permanent damage to the device. These are stress ratings only and operation of the device at these or at any other conditions above those given in the Characteristics sections of the specification is not implied. Exposure to limiting values for extended periods may affect device reliability.	
Application information	
Where application information is given, it is advisory and does not form part of the specification.	

LIFE SUPPORT APPLICATIONS

These products are not designed for use in life support appliances, devices, or systems where malfunction of these products can reasonably be expected to result in personal injury. Philips customers using or selling these products for use in such applications do so at their own risk and agree to fully indemnify Philips for any damages resulting from such improper use or sale.

Inverter

74HC1GU04

NOTES

Inverter

74HC1GU04

NOTES

Inverter

74HC1GU04

NOTES

Philips Semiconductors – a worldwide company

Argentina: see South America

Australia: 34 Waterloo Road, NORTH RYDE, NSW 2113,
Tel. +61 2 9805 4455, Fax. +61 2 9805 4466

Austria: Computerstr. 6, A-1101 WIEN, P.O. Box 213, Tel. +43 160 1010,
Fax. +43 160 101 1210

Belarus: Hotel Minsk Business Center, Bld. 3, r. 1211, Volodarski Str. 6,
220050 MINSK, Tel. +375 172 200 733, Fax. +375 172 200 773

Belgium: see The Netherlands

Brazil: see South America

Bulgaria: Philips Bulgaria Ltd., Energoproject, 15th floor,
51 James Bourchier Blvd., 1407 SOFIA,
Tel. +359 2 689 211, Fax. +359 2 689 102

Canada: PHILIPS SEMICONDUCTORS/COMPONENTS,
Tel. +1 800 234 7381

China/Hong Kong: 501 Hong Kong Industrial Technology Centre,
72 Tat Chee Avenue, Kowloon Tong, HONG KONG,
Tel. +852 2319 7888, Fax. +852 2319 7700

Colombia: see South America

Czech Republic: see Austria

Denmark: Prags Boulevard 80, PB 1919, DK-2300 COPENHAGEN S,
Tel. +45 32 88 2636, Fax. +45 31 57 0044

Finland: Sinikalliontie 3, FIN-02630 ESPOO,
Tel. +358 9 615800, Fax. +358 9 61580920

France: 51 Rue Carnot, BP317, 92156 SURESNES Cedex,
Tel. +33 1 40 99 6161, Fax. +33 1 40 99 6427

Germany: Hammerbrookstraße 69, D-20097 HAMBURG,
Tel. +49 40 23 53 60, Fax. +49 40 23 536 300

Greece: No. 15, 25th March Street, GR 17778 TAVROS/ATHENS,
Tel. +30 1 4894 339/239, Fax. +30 1 4814 240

Hungary: see Austria

India: Philips INDIA Ltd, Band Box Building, 2nd floor,
254-D, Dr. Annie Besant Road, Worli, MUMBAI 400 025,
Tel. +91 22 493 8541, Fax. +91 22 493 0966

Indonesia: PT Philips Development Corporation, Semiconductors Division,
Gedung Philips, Jl. Buncit Raya Kav.99-100, JAKARTA 12510,
Tel. +62 21 794 0040 ext. 2501, Fax. +62 21 794 0080

Ireland: Newstead, Clonskeagh, DUBLIN 14,
Tel. +353 1 7640 000, Fax. +353 1 7640 200

Israel: RAPAC Electronics, 7 Kehilat Saloniki St, PO Box 18053,
TEL AVIV 61180, Tel. +972 3 645 0444, Fax. +972 3 649 1007

Italy: PHILIPS SEMICONDUCTORS, Piazza IV Novembre 3,
20124 MILANO, Tel. +39 2 6752 2531, Fax. +39 2 6752 2557

Japan: Philips Bldg 13-37, Kohnan 2-chome, Minato-ku,
TOKYO 108-8507, Tel. +81 3 3740 5130, Fax. +81 3 3740 5077

Korea: Philips House, 260-199 Itaewon-dong, Yongsan-ku, SEOUL,
Tel. +82 2 709 1412, Fax. +82 2 709 1415

Malaysia: No. 76 Jalan Universiti, 46200 PETALING JAYA, SELANGOR,
Tel. +60 3 750 5214, Fax. +60 3 757 4880

Mexico: 5900 Gateway East, Suite 200, EL PASO, TEXAS 79905,
Tel. +9-5 800 234 7381

Middle East: see Italy

Netherlands: Postbus 90050, 5600 PB EINDHOVEN, Bldg. VB,
Tel. +31 40 27 82785, Fax. +31 40 27 88399

New Zealand: 2 Wagener Place, C.P.O. Box 1041, AUCKLAND,
Tel. +64 9 849 4160, Fax. +64 9 849 7811

Norway: Box 1, Manglerud 0612, OSLO,
Tel. +47 22 74 8000, Fax. +47 22 74 8341

Pakistan: see Singapore

Philippines: Philips Semiconductors Philippines Inc.,
106 Valero St. Salcedo Village, P.O. Box 2108 MCC, MAKATI,
Metro MANILA, Tel. +63 2 816 6380, Fax. +63 2 817 3474

Poland: Ul. Lukiska 10, PL 04-123 WARSZAWA,
Tel. +48 22 612 2831, Fax. +48 22 612 2327

Portugal: see Spain

Romania: see Italy

Russia: Philips Russia, Ul. Usatcheva 35A, 119048 MOSCOW,
Tel. +7 095 755 6918, Fax. +7 095 755 6919

Singapore: Lorong 1, Toa Payoh, SINGAPORE 319762,
Tel. +65 350 2538, Fax. +65 251 6500

Slovakia: see Austria

Slovenia: see Italy

South Africa: S.A. PHILIPS Pty Ltd., 195-215 Main Road Martindale,
2092 JOHANNESBURG, P.O. Box 7430 Johannesburg 2000,
Tel. +27 11 470 5911, Fax. +27 11 470 5494

South America: Al. Vicente Pinzon, 173, 6th floor,
04547-130 SÃO PAULO, SP, Brazil,
Tel. +55 11 821 2333, Fax. +55 11 821 2382

Spain: Balmes 22, 08007 BARCELONA,
Tel. +34 93 301 6312, Fax. +34 93 301 4107

Sweden: Kottbygatan 7, Akalla, S-16485 STOCKHOLM,
Tel. +46 8 5985 2000, Fax. +46 8 5985 2745

Switzerland: Allmendstrasse 140, CH-8027 ZÜRICH,
Tel. +41 1 488 2741 Fax. +41 1 488 3263

Taiwan: Philips Semiconductors, 6F, No. 96, Chien Kuo N. Rd., Sec. 1,
TAIPEI, Taiwan Tel. +886 2 2134 2865, Fax. +886 2 2134 2874

Thailand: PHILIPS ELECTRONICS (THAILAND) Ltd.,
209/2 Sanpavuth-Bangna Road Prakanong, BANGKOK 10260,
Tel. +66 2 745 4090, Fax. +66 2 398 0793

Turkey: Talatpasa Cad. No. 5, 80640 GÜLTEPE/ISTANBUL,
Tel. +90 212 279 2770, Fax. +90 212 282 6707

Ukraine: PHILIPS UKRAINE, 4 Patrice Lumumba str., Building B, Floor 7,
252042 KIEV, Tel. +380 44 264 2776, Fax. +380 44 268 0461

United Kingdom: Philips Semiconductors Ltd., 276 Bath Road, Hayes,
MIDDLESEX UB3 5BX, Tel. +44 181 730 5000, Fax. +44 181 754 8421

United States: 811 East Arques Avenue, SUNNYVALE, CA 94088-3409,
Tel. +1 800 234 7381

Uruguay: see South America

Vietnam: see Singapore

Yugoslavia: PHILIPS, Trg N. Pasica 5/v, 11000 BEOGRAD,
Tel. +381 11 625 344, Fax. +381 11 635 777

For all other countries apply to: Philips Semiconductors,
International Marketing & Sales Communications, Building BE-p, P.O. Box 218,
5600 MD EINDHOVEN, The Netherlands, Fax. +31 40 27 24825

Internet: <http://www.semiconductors.philips.com>

© Philips Electronics N.V. 1998

SCA60

All rights are reserved. Reproduction in whole or in part is prohibited without the prior written consent of the copyright owner.

The information presented in this document does not form part of any quotation or contract, is believed to be accurate and reliable and may be changed without notice. No liability will be accepted by the publisher for any consequence of its use. Publication thereof does not convey nor imply any license under patent- or other industrial or intellectual property rights.

Printed in The Netherlands

245106/00/01/pp16

Date of release: 1998 Nov 18

Document order number: 9397 750 03667

Let's make things better.

Philips



PHILIPS