



MOTOROLA

MC33463

Variable Frequency Micropower DC-to-DC Converter

The MC33463 series are micropower step-up switching voltage regulators, specifically designed for handheld and laptop applications, to provide regulated output voltages using a minimum of external parts. A wide choice of output voltages are available. These devices feature a very low quiescent bias current of 4.0 μ A typical.

The MC33463H-XXKT1 series features a highly accurate voltage reference, an oscillator, a variable frequency modulation (VFM) controller, a driver transistor (Lx), a comparator and feedback resistive divider.

The MC33463H-XXLT1 is identical to the MC33463H-XXKT1, except that a drive pin (EXT) for an external transistor is provided.

Due to the low bias current specifications, these devices are ideally suited for battery powered computer, consumer, and industrial equipment where an extension of useful battery life is desirable.

MC33463 Series Features:

- Low Quiescent Bias Current of 4.0 μ A
- High Output Voltage Accuracy of $\pm 2.5\%$
- Low Startup Voltage of 0.9 V at 1.0 mA
- Wide Output Voltage Range of 2.5 V to 7.5 V Available
- High Efficiency of 80% Typical
- Surface Mount Package

VARIABLE FREQUENCY MICROPOWER DC-to-DC CONVERTER

SEMICONDUCTOR TECHNICAL DATA

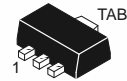

H SUFFIX
PLASTIC PACKAGE
CASE 1213
(SOT-89)

ORDERING INFORMATION

Device	Output Voltage	Type	Operating Temperature Range	Package (Tape/Reel)
MC33463H-30KT1	3.0	Int. Switch	$T_A = -30^\circ$ to $+80^\circ\text{C}$	SOT-89 (Tape)
MC33463H-33KT1	3.3	Switch		
MC33463H-50KT1	5.0	Switch		
MC33463H-30LT1	3.0	Ext. Switch Drive		SOT-89 (Tape)
MC33463H-33LT1	3.3	Switch		
MC33463H-50LT1	5.0	Drive		

Other voltages from 2.5 V to 7.5 V, in 0.1 V increments are available. Consult factory for information.

PIN CONNECTIONS

MC33463H-XXKT1

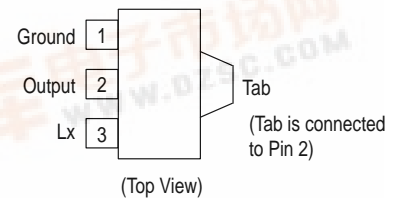

MC33463H-XXLT1

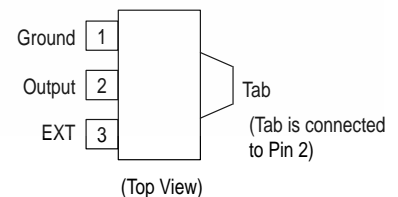

MC33463

Representative Block Diagrams

MC33463H-XXKT1

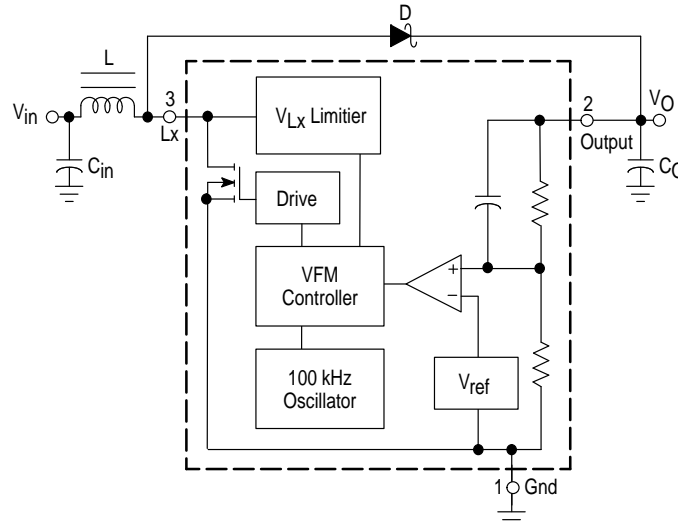

MC33463H-XXLT1

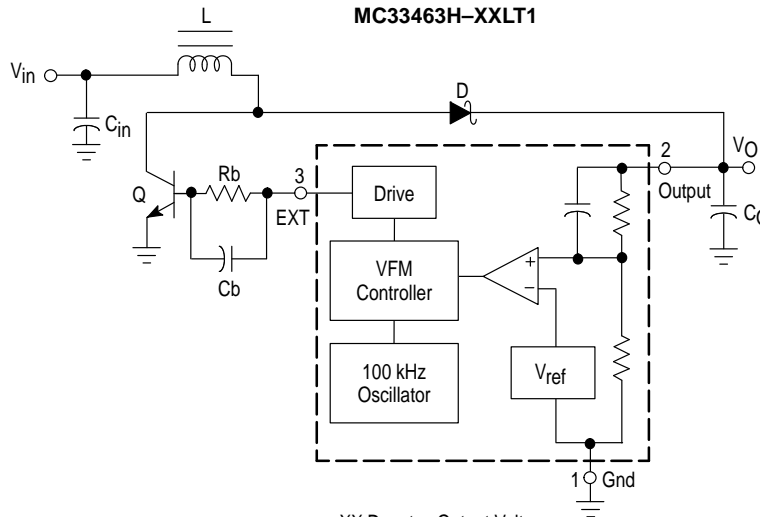

XX Denotes Output Voltage

This device contains 100 active transistors.

MAXIMUM RATINGS ($T_C = 25^\circ\text{C}$, unless otherwise noted.)

Rating	Symbol	Value	Unit
Power Supply Voltage (Transient)	V_{CC}	12	V
Power Supply Voltage (Operating)	V_{CC}	8.0	V
External Pin Voltage	V_{EXT}	-0.3 to V_O	V
Lx Pin Voltage	V_{Lx}	12	V
EXT Pin Source/Sink Current	I_{EXT}	50/50	mA
Lx Pin Sink Current	I_{Lx}	250	mA
Power Dissipation and Thermal Characteristics H Suffix, Plastic Package Case 1213 (SOT-89) Maximum Power Dissipation @ $T_A = 25^\circ\text{C}$ Thermal Resistance, Junction-to-Air	P_D $R_{\theta JA}$	500 200	mW $^\circ\text{C}/\text{W}$
Operating Junction Temperature	T_J	125	$^\circ\text{C}$
Operating Ambient Temperature	T_A	-30 to +80	$^\circ\text{C}$
Storage Temperature Range	T_{stg}	-40 to +125	$^\circ\text{C}$

MC33463

ELECTRICAL CHARACTERISTICS ($V_{CC} = 2.0\text{ V}$, $I_O = 10\text{ mA}$ and $T_A = 25^\circ\text{C}$, unless otherwise noted.)

Characteristic	Symbol	Min	Typ	Max	Unit
OSCILLATOR					
Frequency	f_{osc}	80	100	120	kHz
Oscillator Minimum Supply Voltage ($I_O = 0\text{ mA}$)	V_{CC}	–	0.7	0.8	V
Oscillator Duty Ratio Each Cycle	D	65	75	85	%
Lx OUTPUT (KT1 SUFFIX)					
ON State Sink Current ($V_{Lx} = 0.4\text{ V}$) 30KT1 Suffix 33KT1 Suffix 50KT1 Suffix	I_{Lx}	60 63 80	– – –	– – –	mA
V_{Lx} Voltage Limit (Note 1)	V_{LxLim}	0.65	0.8	1.0	V
OFF State Leakage Current ($V_{Lx} = 6.0\text{ V}$)	I_{LKG}	–	–	0.5	μA
EXT OUTPUT (LT1 SUFFIX)					
ON State Source Current ($V_{EXT} = V_O - 0.4\text{ V}$) 30LT1 Suffix 33LT1 Suffix 50LT1 Suffix	I_{source}	1.5 1.575 2.0	– – –	– – –	mA
OFF State Sink Current ($V_{EXT} = 0.4\text{ V}$) 30LT1 Suffix 33LT1 Suffix 50LT1 Suffix	I_{sink}	1.5 1.575 2.0	– – –	– – –	mA
TOTAL DEVICE					
Output Voltage 30KT1 or 30LT1 Suffix 33KT1 or 33LT1 Suffix 50KT1 or 50LT1 Suffix	V_O	2.925 3.218 4.875	3.0 3.3 5.0	3.075 3.383 5.125	V
Quiescent Bias Current ($V_{in} = 2.0\text{ V}$, $I_O = 0\text{ mA}$) 30KT1 Suffix 33KT1 Suffix 50KT1 Suffix	I_Q	– – –	4.0 4.3 6.0	8.0 8.6 12	μA
Quiescent Bias Current ($V_{in} = V_O + 0.5\text{ V}$, $I_O = 0\text{ mA}$) 30KT1 Suffix 33KT1 Suffix 50KT1 Suffix	I_Q	– – –	1.2 1.2 2.0	5.0 5.0 5.0	μA
Quiescent Bias Current ($V_{in} = 2.0\text{ V}$, $I_O = 0\text{ mA}$) 30LT1 Suffix 33LT1 Suffix 50LT1 Suffix	I_Q	– – –	30 34.5 60	50 56 90	μA
Quiescent Bias Current ($V_{in} = V_O + 0.5\text{ V}$, $I_O = 0\text{ mA}$) 30LT1 Suffix 33LT1 Suffix 50LT1 Suffix	I_Q	– – –	1.2 1.2 2.0	5.0 5.0 5.0	μA

NOTE: 1. When the Lx switch is turned on, I_{Lx} carried through the $R_{DS(on)}$ of the Lx switch results in V_{Lx} . When V_{Lx} reaches V_{LxLim} , the Lx switch is turned off by the Lx switch protection circuit.

MC33463

Figure 1. Quiescent Current versus Temperature

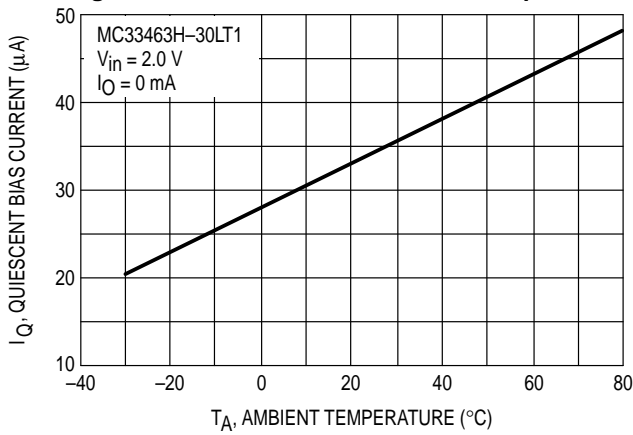

Figure 2. Quiescent Current versus Temperature

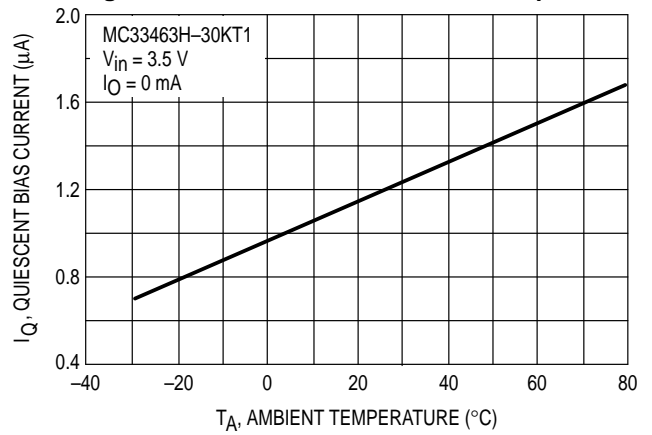

Figure 3. Oscillator Frequency versus Temperature

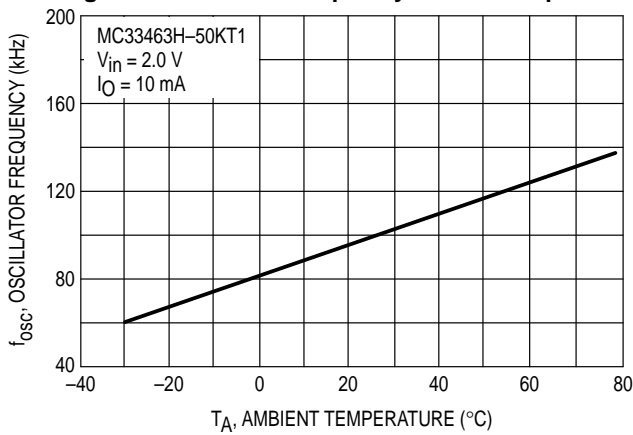

Figure 4. Oscillator Duty Ratio versus Temperature

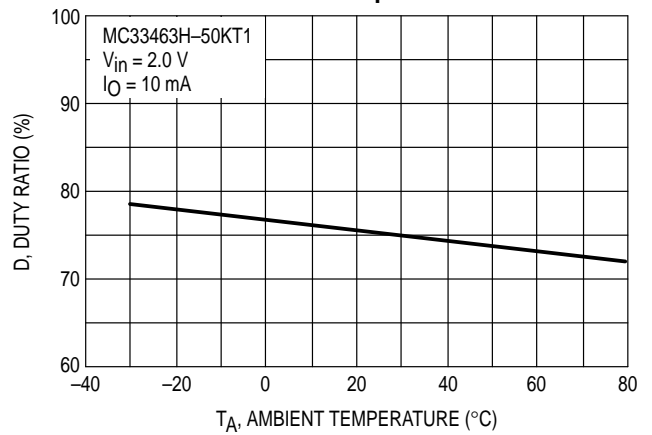

Figure 5. Lx Switching Current versus Temperature

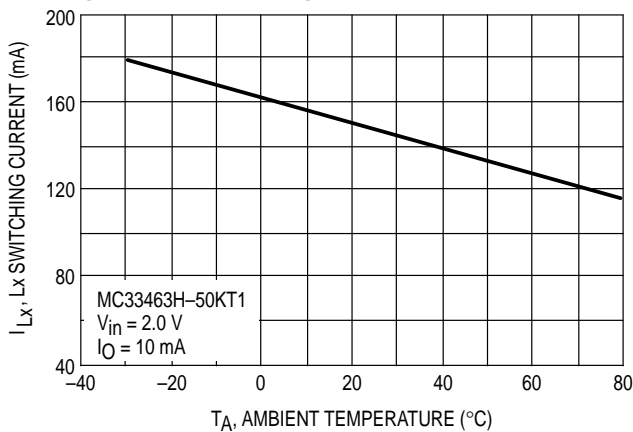
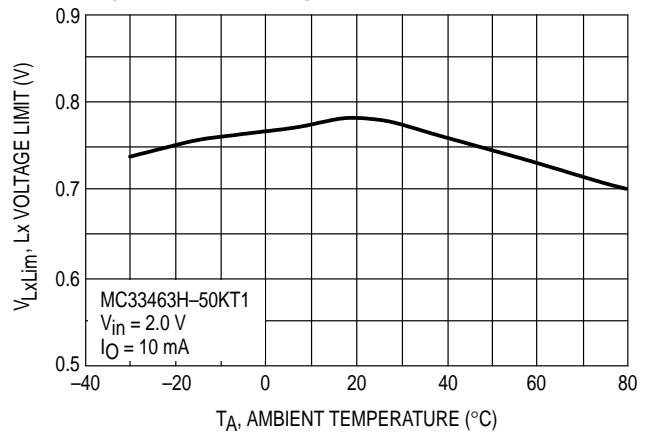

Figure 6. V_{Lx} Voltage Limit versus Temperature



MC33463

Figure 7. Output Voltage versus Output Current

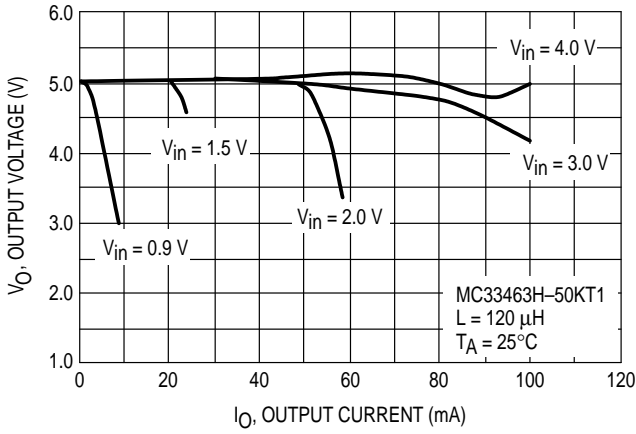

Figure 8. Output Voltage versus Output Current

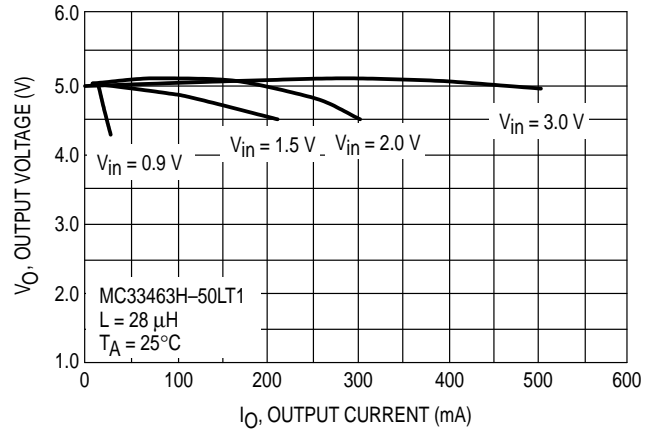

Figure 9. Efficiency versus Output Current

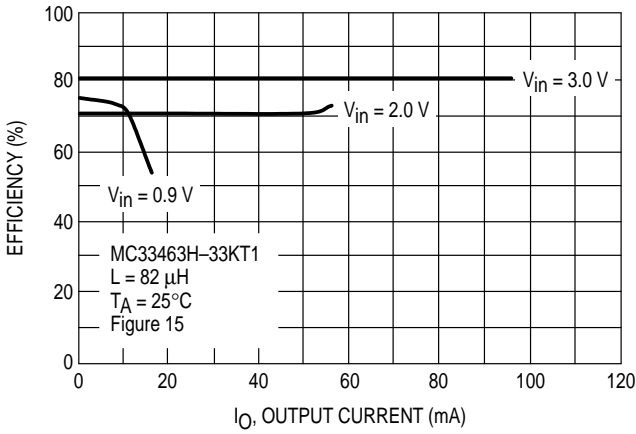

Figure 10. Efficiency versus Output Current

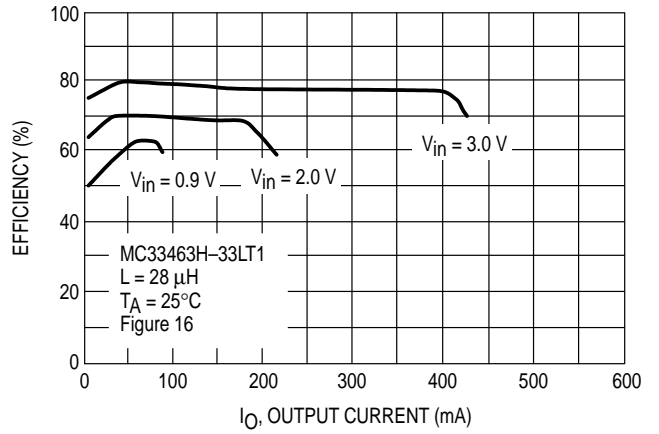

Figure 11. Startup/Hold Voltage versus Output Current

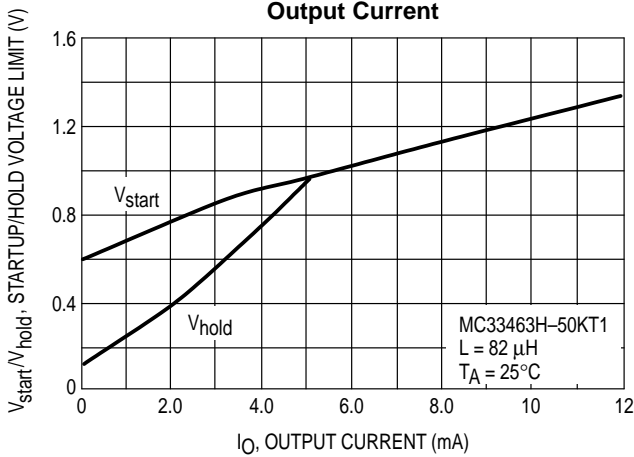
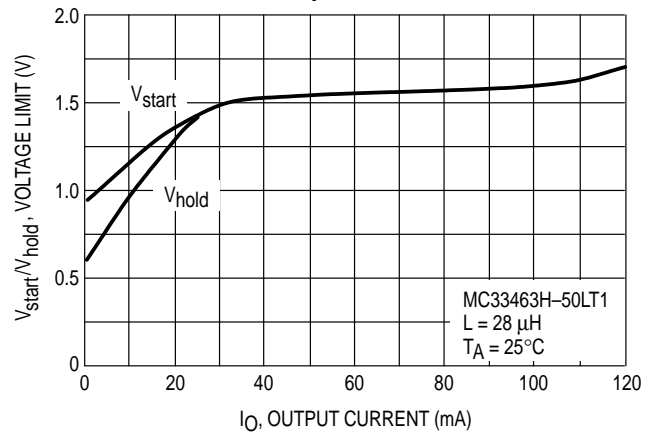
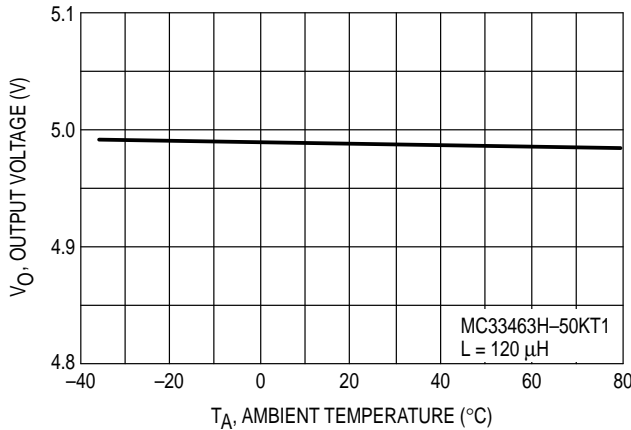

Figure 12. Startup/Hold Voltage versus Output Current



MC33463

Figure 13. Output Voltage versus Temperature



DEFINITIONS

Quiescent Bias Current – Current which is used to operate the switching regulator chip and is not delivered to the load.

Leakage Current – Current drawn through a transistor junction, under a specified collector voltage, when the transistor is off.

FUNCTIONAL DESCRIPTION

Introduction

The MC33463 series are monolithic power switching regulators optimized for dc-to-dc converter applications where power drain must be minimized. The combination of features in this series allows the system designer to directly implement step-up, step-down or flyback converters with a small number of external components. Potential applications include low power consumer products and battery powered portable products. Typical application circuits are shown in Figure 15 and Figure 16.

Operating Description

The MC33463 series converters each operate as a fixed on-time, variable off-time voltage mode ripple regulator. Operation is intended to be in the discontinuous mode, where the inductor current ramps up to a peak value which is greater than or equal to twice the value of the dc input current during the on-time of the transistor switch. During the off-time of the transistor switch, the inductor current ramps down to zero and remains at zero until another switching cycle begins.

Because the output voltage pin is also used as the supply voltage for powering internal circuitry, an external startup circuit is needed in step-down and flyback converter designs to provide initial power to the integrated circuit to begin switching. The startup circuit needed can be three discrete

Figure 14. Startup/Hold Voltage versus Temperature

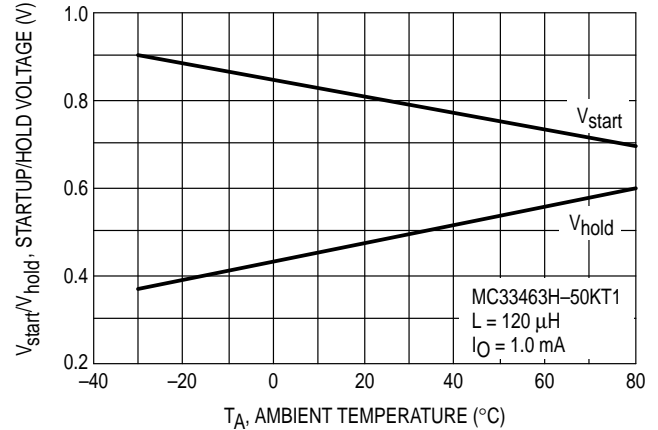

components, as shown in Figure 17, or a micropower undervoltage sensor, as shown in Figure 18.

Oscillator

The oscillator frequency, is internally programmed to 100 kHz. The duty ratio of the oscillator is designed for a constant value of 0.75 nominal. Hence the nominal on-time of the power switch is:

$$t_{on} = \frac{D}{f_{osc}} = \frac{0.75}{(100 \text{ kHz})} = 7.5 \mu\text{s}$$

Feedback Comparator

The output voltage is sensed and fed to a high speed comparator noninverting input through an internal resistive divider. The comparator inverting input is connected to an internally trimmed to 0.7 V reference.

With a voltage mode ripple converter operating under normal conditions, output switch conduction is initiated and terminated by the oscillator, off-time is controlled by the high speed voltage feedback comparator.

Driver and Output Switch

To aid in system design flexibility and conversion efficiency, two output driver options are provided. The MC33463H-XXKT1 converters have an internal drive transistor which is capable of sinking currents greater than 60 mA into the L_x pin. An internal V_{Lx} limiter circuit senses if the L_x pin voltage exceeds 1.0 V during t_{on} and turns off the drive transistor. The MC33463H-XXLT1 provides output drive for an external transistor.

Applications

The following converter applications show the simplicity and flexibility of the converter architecture. Three main converter topologies are demonstrated in Figures 15 through 19.

MC33463

Figure 15. MC33463H-50KT1 Typical Step-Up Application

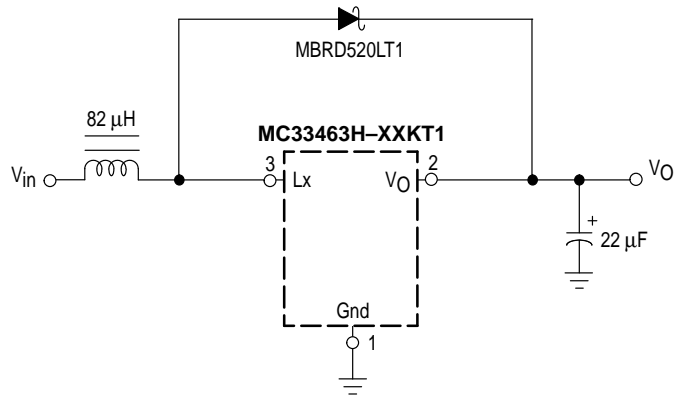
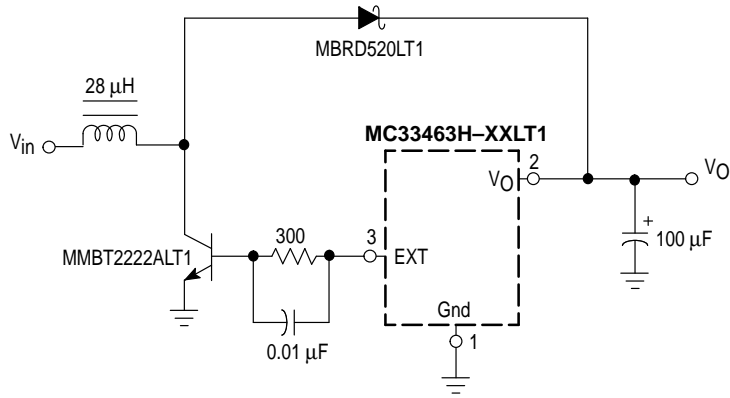
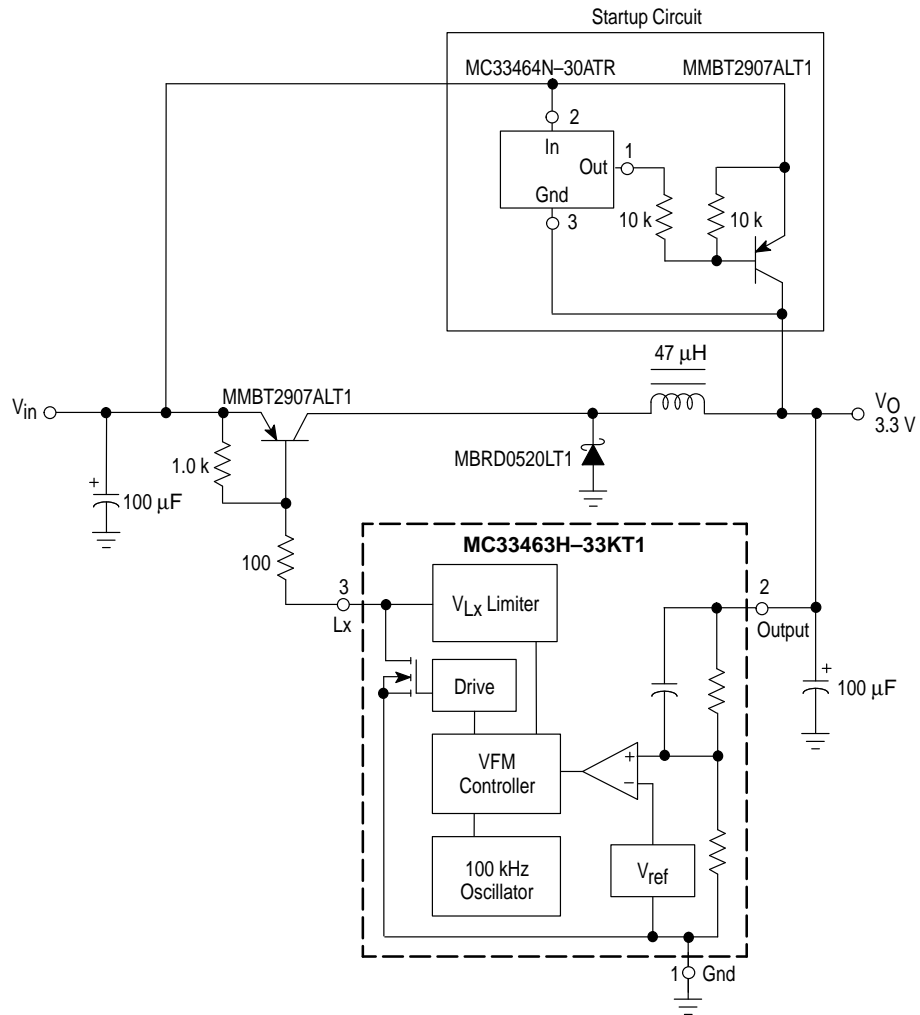

Figure 16. MC33463H-50LT1 Typical Step-Up Application



MC33463

Figure 18. Micropower Step-Down Application



MC33463

Figure 19. Flyback Application

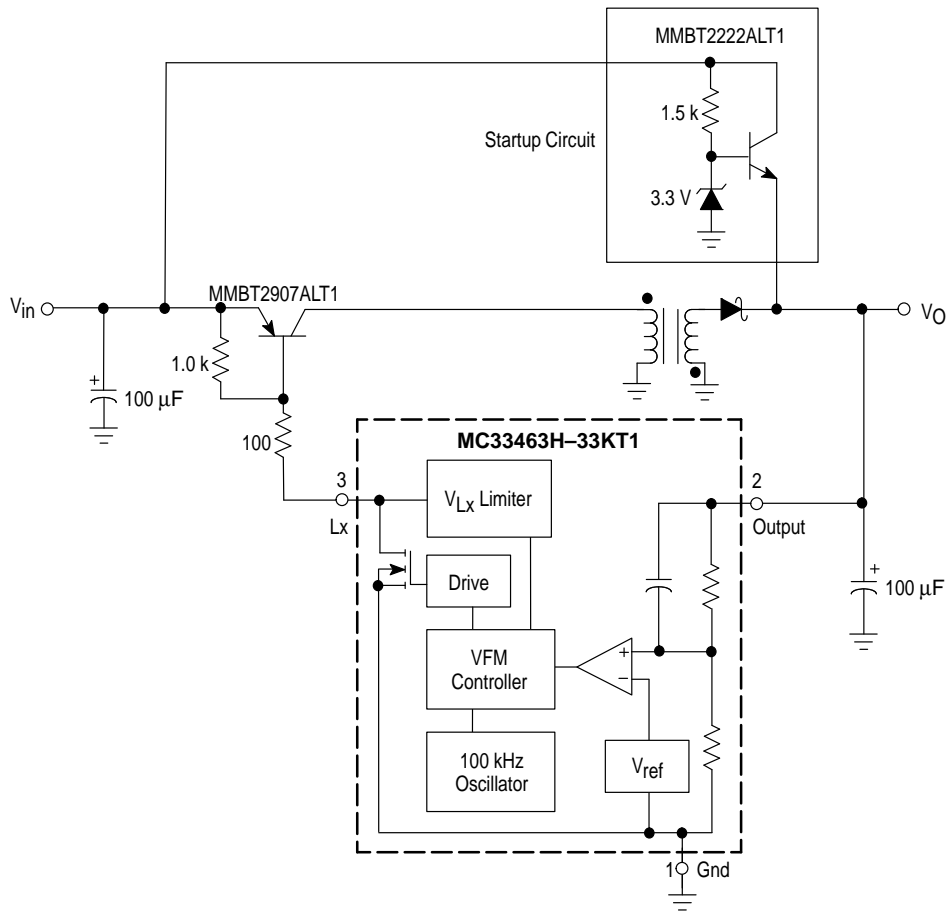

MC33463

Figure 20. Design Equations

Calculation	Step-Down	Step-Up	Flyback
t_{on}	$\frac{D}{f_{osc}}$	$\frac{D}{f_{osc}}$	$\frac{D}{f_{osc}}$
L	$< t_{on} \left[\frac{(V_{in} - V_{sat} - V_O)}{(2I_O)} \right]$	$< \frac{(n)(V_{in})^2(t_{on})}{P_O}$	$< \frac{(n)(V_{in})^2(t_{on})}{P_O}$
$I_{L(avg)}$	I_O	I_{in}	I_{in}
$I_{L(pk)}$	$\frac{(V_{in} - V_{sat} - V_O)(t_{on})}{L}$	$\frac{(V_{in} - V_{sat})(t_{on})}{L}$	$\frac{(V_{in} - V_{sat})(t_{on})}{L}$
$V_{ripple(pp)}$	$\Delta I_L \left[\left(\frac{1}{16f_{osc}C_O} \right)^2 + (ESR)^2 \right]^{\frac{1}{2}}$	$\approx \frac{(t_{on})(I_O)}{(C_O)}$	$\approx \frac{(t_{on})(I_O)}{(C_O)}$

The following converter design characteristics must be chosen:

V_{in} – Nominal Operating dc input voltage

V_O – Desired dc output voltage

I_O – Desired dc output current

$V_{ripple(pp)}$ – Desired peak-to-peak output ripple voltage. For best performance the ripple voltage should be kept to a low value since it will directly affect line and load regulation. Capacitor C_O should be a low equivalent series resistance (ESR) electrolytic designed for switching regulator applications.

NOTE: 1. V_{sat} – Saturation voltage of the switching transistor.
 n – Estimated circuit efficiency.

MC33463

OUTLINE DIMENSIONS

H SUFFIX
PLASTIC PACKAGE
CASE 1213-01
(SOT-89)
ISSUE O

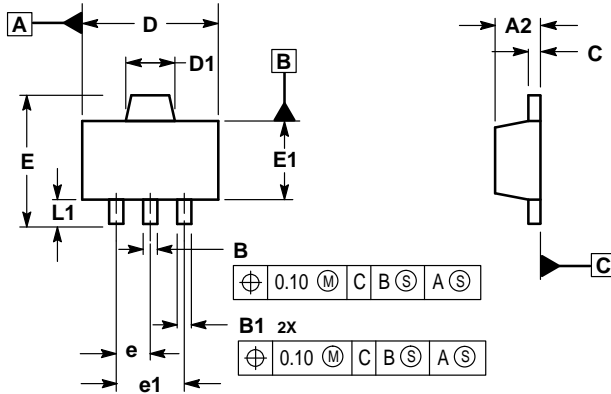

NOTES:

1. DIMENSIONS ARE IN MILLIMETERS.
2. INTERPRET DIMENSIONS AND TOLERANCING PER ASME Y14.5M, 1994.
3. DATUM C IS A SEATING PLANE.

DIM	MILLIMETERS	
	MIN	MAX
A2	1.40	1.60
B	0.37	0.57
B1	0.32	0.52
C	0.30	0.50
D	4.40	4.60
D1	1.50	1.70
E	—	4.25
E1	2.40	2.60
e	1.50 BSC	
e1	3.00 BSC	
L1	0.80	—

Motorola reserves the right to make changes without further notice to any products herein. Motorola makes no warranty, representation or guarantee regarding the suitability of its products for any particular purpose, nor does Motorola assume any liability arising out of the application or use of any product or circuit, and specifically disclaims any and all liability, including without limitation consequential or incidental damages. "Typical" parameters which may be provided in Motorola data sheets and/or specifications can and do vary in different applications and actual performance may vary over time. All operating parameters, including "Typicals" must be validated for each customer application by customer's technical experts. Motorola does not convey any license under its patent rights nor the rights of others. Motorola products are not designed, intended, or authorized for use as components in systems intended for surgical implant into the body, or other applications intended to support or sustain life, or for any other application in which the failure of the Motorola product could create a situation where personal injury or death may occur. Should Buyer purchase or use Motorola products for any such unintended or unauthorized application, Buyer shall indemnify and hold Motorola and its officers, employees, subsidiaries, affiliates, and distributors harmless against all claims, costs, damages, and expenses, and reasonable attorney fees arising out of, directly or indirectly, any claim of personal injury or death associated with such unintended or unauthorized use, even if such claim alleges that Motorola was negligent regarding the design or manufacture of the part. Motorola and  are registered trademarks of Motorola, Inc. Motorola, Inc. is an Equal Opportunity/Affirmative Action Employer.

Mfax is a trademark of Motorola, Inc.

How to reach us:

USA/EUROPE/Locations Not Listed: Motorola Literature Distribution;
P.O. Box 5405, Denver, Colorado 80217. 1-303-675-2140 or 1-800-441-2447

JAPAN: Motorola Japan Ltd.; SPD, Strategic Planning Office, 141,
4-32-1 Nishi-Gotanda, Shinagawa-ku, Tokyo, Japan. 81-3-5487-8488

Customer Focus Center: 1-800-521-6274

Mfax™: RMFAX0@email.sps.mot.com – TOUCHTONE 1-602-244-6609
Motorola Fax Back System – US & Canada ONLY 1-800-774-1848
– <http://sps.motorola.com/mfax/>

ASIA/PACIFIC: Motorola Semiconductors H.K. Ltd.; Silicon Harbour Centre,
2, Dai King Street, Tai Po Industrial Estate, Tai Po, N.T., Hong Kong.
852-26629298

HOME PAGE: <http://motorola.com/sps/>