



June 1994

LM3911 Temperature Controller

General Description

The LM3911 is a highly accurate temperature measurement and/or control system for use over a -25°C to $+85^{\circ}\text{C}$ temperature range. Fabricated on a single monolithic chip, it includes a temperature sensor, a stable voltage reference and an operational amplifier.

The output voltage of the LM3911 is directly proportional to temperature in degrees Kelvin at $10\text{ mV}/^{\circ}\text{K}$. Using the internal op amp with external resistors any temperature scale factor is easily obtained. By connecting the op amp as a comparator, the output will switch as the temperature transverse the set-point making the device useful as an on-off temperature controller.

An active shunt regulator is connected across the power leads of the LM3911 to provide a stable 6.8V voltage reference for the sensing system. This allows the use of any power supply voltage with suitable external resistors.

The input bias current is low and relatively constant with temperature, ensuring high accuracy when high source impedance is used. Further, the output collector can be returned to a voltage higher than 6.8V allowing the LM3911 to drive lamps and relays up to a 35V supply.

The LM3911 uses the difference in emitter-base voltage of transistors operating at different current densities as the basic temperature sensitive element. Since this output depends only on transistor matching the same reliability and stability as present op amps can be expected.

The LM3911 is available in two package styles, a metal can TO-46 and an 8-lead epoxy mini-DIP. In the epoxy package all electrical connections are made on one side of the device allowing the other 4 leads to be used for attaching the LM3911 to the temperature source. The LM3911 is rated for operation over a -25°C to $+85^{\circ}\text{C}$ temperature range.

Features

- Uncalibrated accuracy $\pm 10^{\circ}\text{C}$
- Internal op amp with frequency compensation
- Linear output of $10\text{ mV}/^{\circ}\text{K}$ ($10\text{ mV}/^{\circ}\text{C}$)
- Can be calibrated in degrees Kelvin, Celsius or Fahrenheit
- Output can drive loads up to 35V
- Internal stable voltage reference
- Low cost

Block Diagram

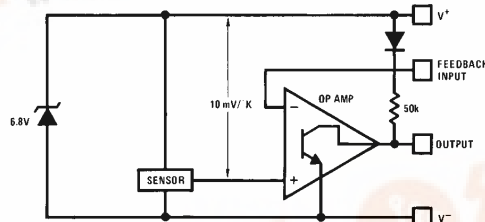

Typical Applications

Ground Referred Centigrade Thermometer

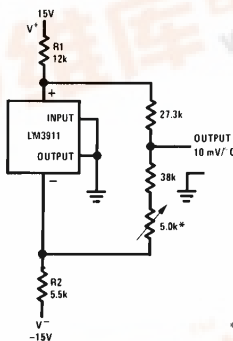

* Trims out initial zener tolerance. Set output to read C

Basic Temperature Controller

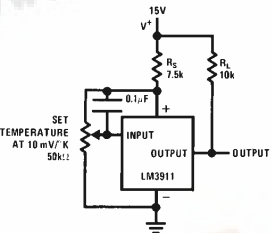

* Output goes negative on temperature increase
 $R_S = (V^+ - 6.8\text{V})\text{ k}\Omega$

Proportioning Temperature Controller

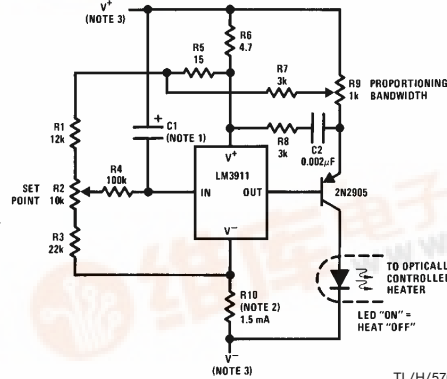

Note 1: $C1$ determines proportioning frequency $f \approx \frac{1}{2R4 C1}$

Note 2: $R10 = \frac{|V^+| + |V^-| - 7\text{V}}{0.0015\text{A}}$

Note 3: Either V^- or V^+ can be ground.

LM3911 Temperature Controller



Absolute Maximum Ratings

If Military/Aerospace specified devices are required, please contact the National Semiconductor Sales Office/Distributors for availability and specifications.

Supply Current (Externally Set)	10 mA
Output Collector Voltage, V ⁺	36V
Feedback Input Voltage Range	0V to +7.0V

Output Short Circuit Duration	Indefinite
Operating Temperature Range	-25°C to +85°C
Storage Temperature Range	-65°C to +150°C
Lead Temperature (Soldering, 10 seconds)	260°C

Electrical Characteristics (Note 1)

Parameter	Conditions	Min	Typ	Max	Units
SENSOR					
Output Voltage	T _A = -25°C, (Note 2)	2.36	2.48	2.60	V
Output Voltage	T _A = +25°C, (Note 2)	2.88	2.98	3.08	V
Output Voltage	T _A = +85°C, (Note 2)	3.46	3.58	3.70	V
Linearity	ΔT = 100°C		0.5	2	%
Long-Term Stability			0.3		%
Repeatability			0.3		%
VOLTAGE REFERENCE					
Reverse Breakdown Voltage	1 mA ≤ I _Z ≤ 5 mA	6.55	6.85	7.25	V
Reverse Breakdown Voltage Change With Current	1 mA ≤ I _Z ≤ 5 mA		10	35	mV
Temperature Stability			20	85	mV
Dynamic Impedance	I _Z = 1 mA		3.0		Ω
RMS Noise Voltage	10 Hz ≤ f ≤ 10 kHz		30		μV
Long Term Stability	T _A = +85°C		6.0		mV
OP AMP					
Input Bias Current	T _A = +25°C		35	150	nA
Input Bias Current			45	250	nA
Voltage Gain	R _L = 36k, V ⁺ = 36V	2500	15000		V/V
Output Leakage Current	T _A = 25°C (Note 3)		0.2	2	μA
Output Leakage Current	(Note 3)		1.0	8	μA
Output Source Current	V _{OUT} ≤ 3.70	10			μA
Output Sink Current	1V ≤ V _{OUT} ≤ 36V	2.0			mA

Note 1: These specifications apply for -25°C ≤ T_A ≤ +85°C and 0.9 mA ≤ I_{SUPPLY} ≤ 1.1 mA unless otherwise specified; C_L ≤ 50 pF.

Note 2: The output voltage applies to the basic thermometer configuration with the output and input terminals shorted and a load resistance of ≥ 1.0 MΩ. This is the feedback sense voltage and includes errors in both the sensor and op amp. This voltage is specified for the sensor in a rapidly stirred oil bath. The output is referred to V⁺.

Note 3: The output leakage current is specified with ≥ 100 mV overdrive. Since this voltage changes with temperature, the voltage drive for turn-off changes and is defined as V_{OUT} (with output and input shorted) - 100 mV. This specification applies for V_{OUT} = 36V.

Application Hints

Although the LM3911 is designed to be totally trouble-free, certain precautions should be taken to insure the best possible performance.

As with any temperature sensor, internal power dissipation will raise the sensor's temperature above ambient. Nominal suggested operating current for the shunt regulator is 1.0 mA and causes 7.0 mW of power dissipation. In free, still, air this raises the package temperature by about 1.2°K. Although the regulator will operate at higher reverse currents and the output will drive loads up to 5.0 mA, these higher currents will raise the sensor temperature to about 19°K above ambient-degrading accuracy. Therefore, the sensor should be operated at the lowest possible power level.

With moving air, liquid or surface temperature sensing, self-heating is not as great a problem since the measured

media will conduct the heat from the sensor. Also, there are many small heat sinks designed for transistors which will improve heat transfer to the sensor from the surrounding medium. A small finned clip-on heat sink is quite effective in free-air. It should be mentioned that the LM3911 die is on the base of the package and therefore coupling to the base is preferable.

The internal reference regulator provides a temperature stable voltage for offsetting the output or setting a comparison point in temperature controllers. However, since this reference is at the same temperature as the sensor temperature, changes will also cause reference drift. For application where maximum accuracy is needed an external reference should be used. Of course, for fixed temperature controllers the internal reference is adequate.

Typical Performance Characteristics

Temperature Conversion

$$T_{\text{CENTIGRADE}} = T_C$$

$$T_{\text{FAHRENHEIT}} = T_F$$

$$T_{\text{KELVIN}} = T_K$$

$$T_K = T_C + 273.16$$

$$T_C = (40 + T_F) \frac{5}{9} - 40$$

$$T_F = (40 + T_C) \frac{9}{5} - 40$$

Op Amp Input Current

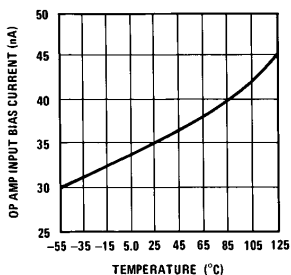

Power Supply Current

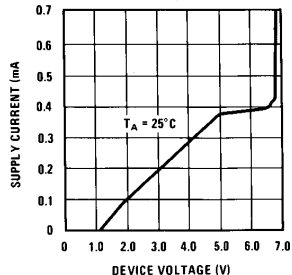

Output Saturation Voltage

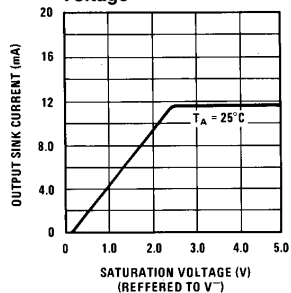

Thermal Time Constant in Stirred Oil Bath

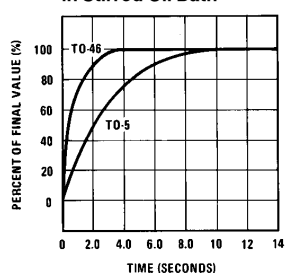

Thermal Time Constant in Still Air

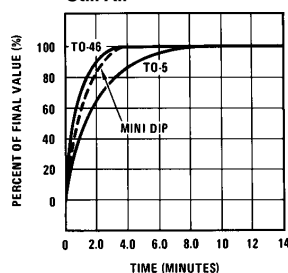

Supply Sensitivity

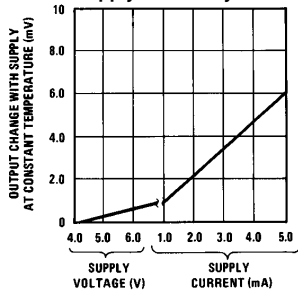

Device Temperature Rise

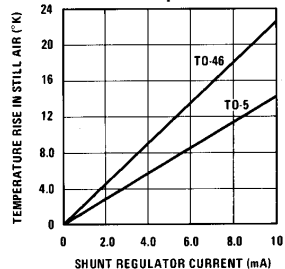

Device Temperature Rise

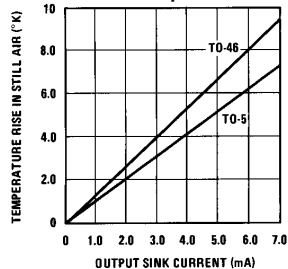

Reference Regulation

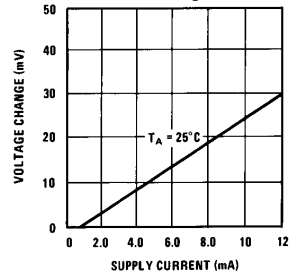

Turn "ON" Response

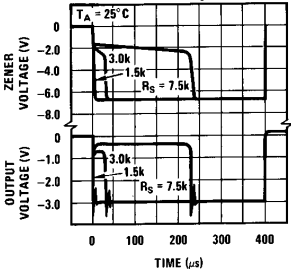

Amplifier Output Impedance

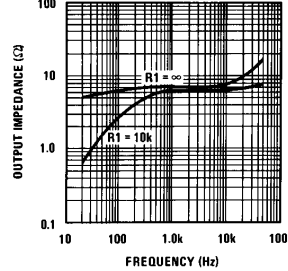

TL/H/5701-2

Schematic Diagram

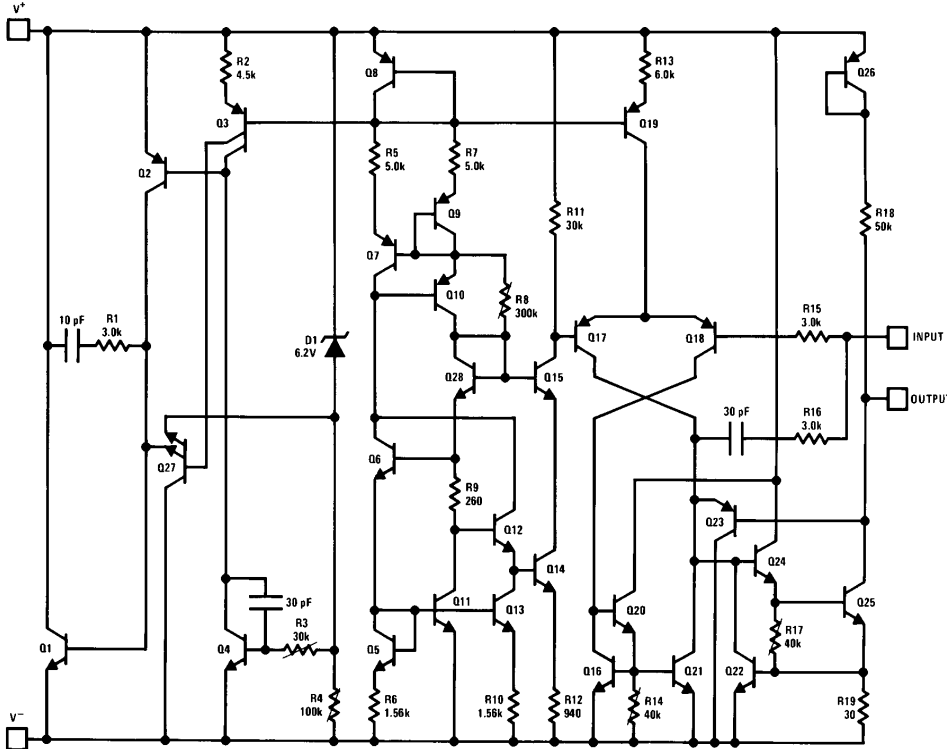

Typical Applications (Continued)

Basic Thermometer for Negative Supply

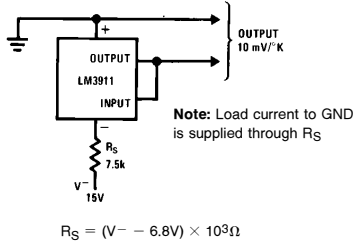

Basic Thermometer for Positive Supply

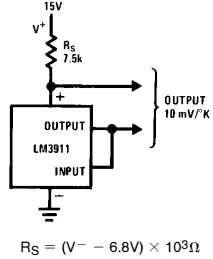

Increasing Output Drive

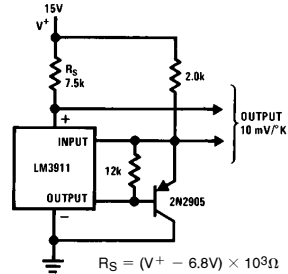

External Frequency Compensation for Greater Stability when Driving Capacitive Loads

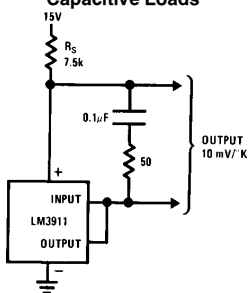

Operating With External Zener for Lower Power Dissipation

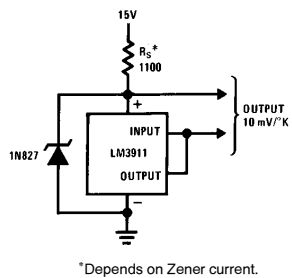

Temperature Controller With Hysteresis

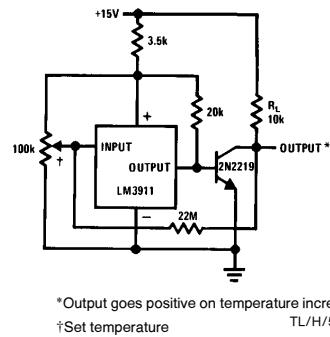

Typical Applications (Continued)

Thermometer With Meter Output

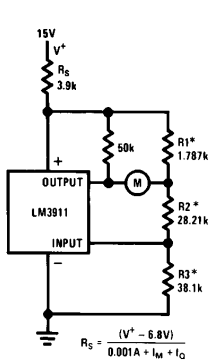

$$R1 = \frac{(V_Z) 0.01 \Delta T}{I_M (V_Z - 0.01 T_O)} \quad **$$

$$\text{Select } I_Q \leq \frac{2V}{R1}$$

$$R2 = \frac{0.01 T_O - I_Q R1}{I_Q}$$

$$R3 = \frac{V_Z}{I_Q} - R1 - R2$$

$$(I_Q \leq \frac{2V}{R1})$$

V_Z = Shunt regulator voltage (use 6.85)

ΔT = Meter temperature span ($^{\circ}K$)

I_M = Meter full scale current (A)

T_O = Meter zero temperature ($^{\circ}K$)

I_Q = Current through R1, R2, R3 at zero meter current (10 μA to 1.0 mA) (A)

*Values shown for:

$T_O = 300^{\circ}K$, $\Delta T = 100^{\circ}K$,

$I_M = 1.0 \text{ mA}$, $I_Q = 100 \mu A$

**The 0.01 in the above and following equations is in units of $V/^{\circ}K$ or $V/^{\circ}C$, and is a result of the basic $0.01V/^{\circ}K$ sensitivity of the transducer

Meter Thermometer With Trimmed Output

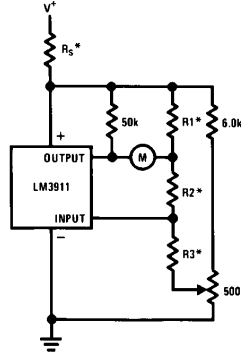

*Selected as for meter thermometer except T_O should be $5^{\circ}K$ more than desired and $I_Q = 100 \mu A$

†Calibrates T_O

Ground Referred Thermometer

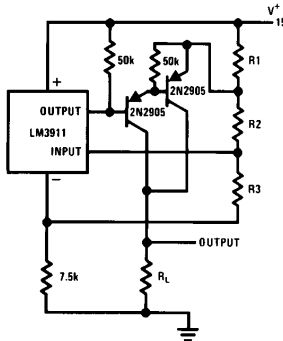

$$R1 = \frac{(V_Z)(10mV)(\Delta T)}{V_O (V_Z - 0.01 T_O)}$$

$$R2 = \frac{0.01 T_O - I_Q R1}{I_Q}$$

$$R3 = \frac{V_Z}{I_Q} - R1 - R2$$

V_Z = Shunt regulator voltage

ΔT = Temperature span ($^{\circ}K$)

T_O = Temperature for zero output ($^{\circ}K$)

V_O = Full scale output voltage $\leq 10V$

I_Q = Current through R1, R2, R3 at zero output voltage (typically 100 μA to 1.0 mA)

Ground Referred Centigrade Thermometer

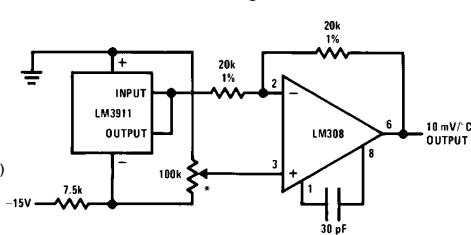

*Set zero

Two Terminal Temperature to Current Transducer*

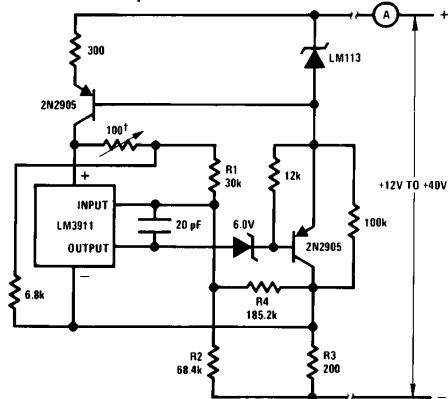

$$R2 (\Omega) = \frac{(V_Z - 0.01 T_L) \left(I_H - \frac{0.01 T_H}{R1} \right) + (V_Z - 0.01 T_H) \left(\frac{0.01 T_L}{R1} - I_L \right)}{\frac{0.01}{R1 R3} [T_H (V_Z - 0.01 T_L) - T_L (V_Z - 0.01 T_H)]}$$

$$R3 (\Omega) \geq \frac{V_Z \left(\frac{T_H}{T_L} - 1 \right)}{I_H - \frac{I_L T_H}{T_L}}$$

$$\frac{1}{R4} = \frac{1}{(V_Z - 0.01 T_L)(R2)} \left[\frac{(R2)(0.01 T_L)}{R1} + \frac{(V_Z - 0.01 T_L - I_L)}{\frac{1}{R2} + \frac{1}{R3}} \right] - \frac{1}{R2}$$

T_L = Temperature for I_L (K)

T_H = Temperature for I_H (K)

V_Z = Zener voltage (V)

I_L = Low temperature output current (A)

I_H = High temperature output current (A)

*Values shown for $I_{OUT} = 1 \text{ mA}$ to 10 mA for $10^{\circ}F$ to $100^{\circ}F$

†Set temperature

TL/H/5701-4

**The 0.01 in the above and following equations is in units of $V/^{\circ}K$ or $V/^{\circ}C$, and is a result of the basic $0.01V/^{\circ}K$ sensitivity of the transducer

Typical Applications (Continued)

Over Temperature Detectors With Common Output

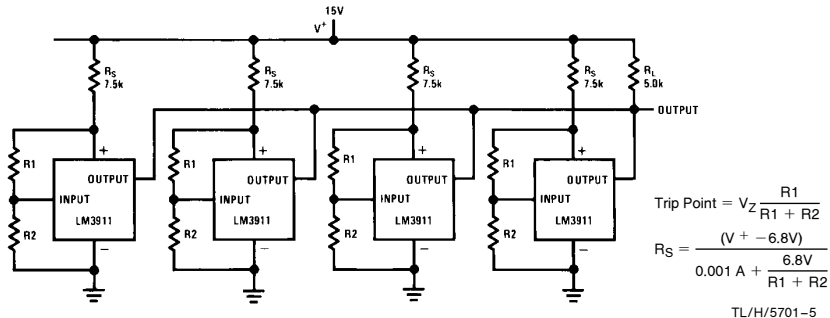

Two-Wire Remote A.C. Electronic Thermostat (Gas or Oil Furnace Control)

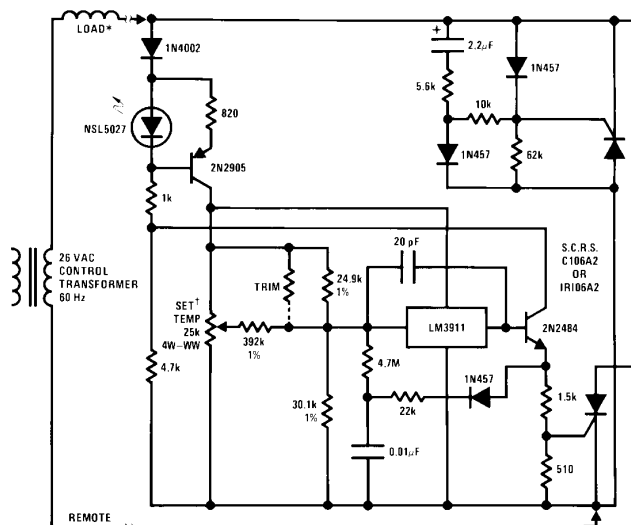

TL/H/5701-8

*Solenoid or 6-15W heater

†Pot will provide about a 50°F to 90°F setting range. The trim resistor (100k) is selected to bring 70°F near the middle of the pot rotation.

SCR heating, by proper positioning, can preheat the sensor giving control anticipation as is presently used in many home thermostats.

Electronic Thermostat

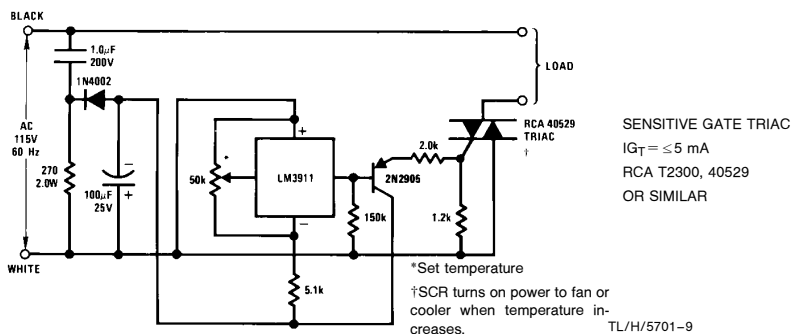

Typical Applications (Continued)

Three-Wire Electronic Thermostat

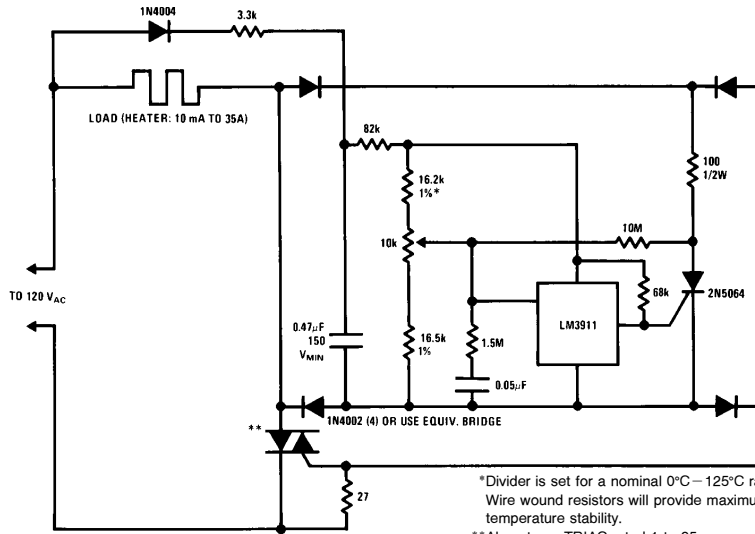

*Divider is set for a nominal 0°C – 125°C range.
Wire wound resistors will provide maximum temperature stability.
**Almost any TRIAC rated 1 to 35 amperes usable with appropriate load.

Differential Thermometer

Kelvin Thermometer With Ground Referred Output

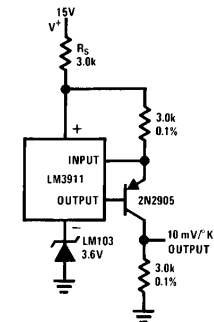

$$R_S = \frac{V_S^+ - 6.8V \times 10^3 \Omega}{2}$$

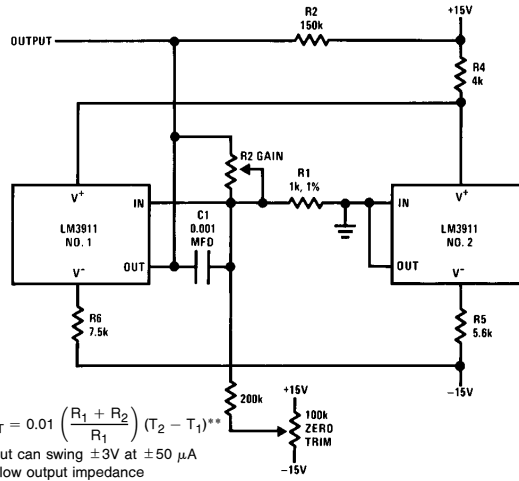

$$V_{OUT} = 0.01 \left(\frac{R_1 + R_2}{R_1} \right) (T_2 - T_1)**$$

Output can swing $\pm 3V$ at $\pm 50 \mu A$ with low output impedance

**The 0.01 in the above equation is in units of V/°K or V/°C, and is a result of the basic 0.01 V/°K sensitivity of the transducer

Connection Diagrams

Dual-In-Line Package

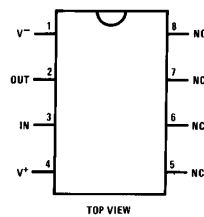

Order Number LM3911N
See NS Package N08E

TL/H/5701-6

TO-46 Package

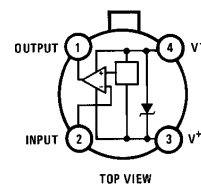

Note: Pin 4 connected to case.

Order Number LM3911H-46
See NS Package H04A

TL/H/5701-7

Physical Dimensions inches (millimeters)

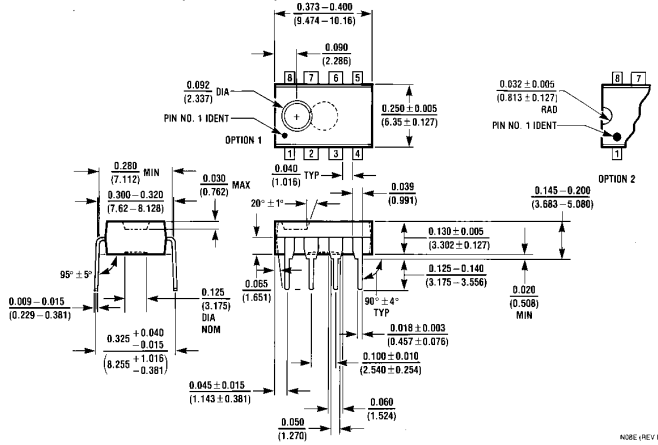

Molded Dual-In-Line Package (N)
Order Number LM3911N
NS Package N08E

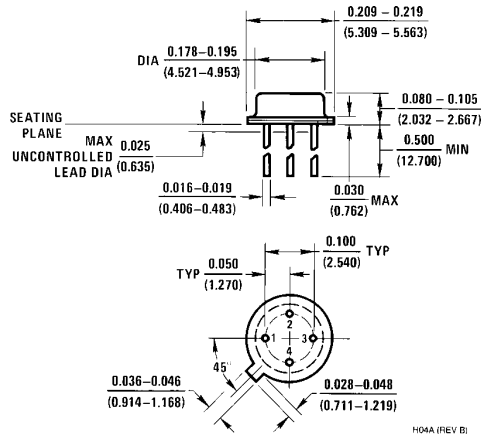

TO-46 Package (H)
Order Number LM3911H-46
NS Package H04A

LIFE SUPPORT POLICY

NATIONAL'S PRODUCTS ARE NOT AUTHORIZED FOR USE AS CRITICAL COMPONENTS IN LIFE SUPPORT DEVICES OR SYSTEMS WITHOUT THE EXPRESS WRITTEN APPROVAL OF THE PRESIDENT OF NATIONAL SEMICONDUCTOR CORPORATION. As used herein:

1. Life support devices or systems are devices or systems which, (a) are intended for surgical implant into the body, or (b) support or sustain life, and whose failure to perform, when properly used in accordance with instructions for use provided in the labeling, can be reasonably expected to result in a significant injury to the user.
2. A critical component is any component of a life support device or system whose failure to perform can be reasonably expected to cause the failure of the life support device or system, or to affect its safety or effectiveness.



National Semiconductor Corporation
 1111 West Bardin Road
 Arlington, TX 76017
 Tel: 1(800) 272-9959
 Fax: 1(800) 737-7018

National Semiconductor Europe
 Fax: (+49) 0-180-530 85 86
 Email: cnjwge@tevm2.nsc.com
 Deutsch Tel: (+49) 0-180-530 85 85
 English Tel: (+49) 0-180-532 78 32
 Français Tel: (+49) 0-180-532 93 58
 Italiano Tel: (+49) 0-180-534 16 80

National Semiconductor Hong Kong Ltd.
 13th Floor, Straight Block,
 Ocean Centre, 5 Canton Rd.
 Tsimshatsui, Kowloon
 Hong Kong
 Tel: (852) 2737-1600
 Fax: (852) 2736-9960

National Semiconductor Japan Ltd.
 Tel: 81-043-299-2309
 Fax: 81-043-299-2408