

Dual Supply ECL-TTL 1:8 Clock Driver

The MC10H/100H643 is a dual supply, low skew translating 1:8 clock driver. Devices in the Motorola H600 translator series utilize the 28-lead PLCC for optimal power pinning, signal flow through and electrical performance. The dual-supply H643 is similar to the H641, which is a single-supply 1:9 version of the same function.

The device features a 48mA TTL output stage, with AC performance specified into a 50pF load capacitance. A Latch is provided on-chip. When LEN is LOW (or left open, in which case it is pulled LOW by the internal pulldowns) the latch is transparent. A HIGH on the enable pin (EN) forces all outputs LOW.

The 10H version is compatible with MECL 10H™ ECL logic levels. The 100H version is compatible with 100K levels.

- ECL/TTL Version of Popular ECLinPS™ E111
- Low Skew Within Device 0.5ns
- Guaranteed Skew Spec Part-to-Part 1.0ns
- Latch
- Differential Internal Design
- V_{BB} Output
- Dual Supply
- Reset/Enable
- Multiple TTL and ECL Power/Ground Pins

MC10H643
MC100H643

DUAL SUPPLY
ECL-TTL 1:8
CLOCK DRIVER

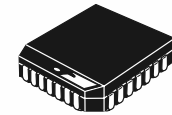

FN SUFFIX
PLASTIC PACKAGE
CASE 776-02

Pinout: 28-Lead PLCC (Top View)

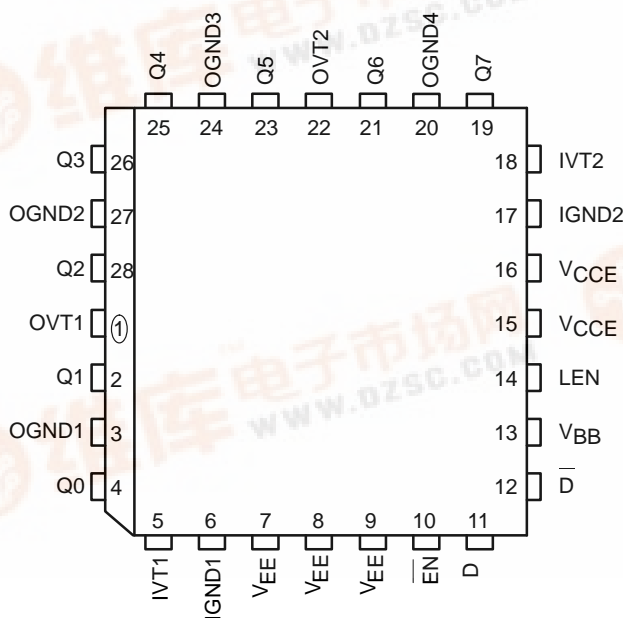

PIN NAMES

PIN	FUNCTION
OGND	TTL Output Ground (0V)
OVT	TTL Output V _{CC} (+5.0V)
IGND	Internal TTL GND (0V)
IVT	Internal TTL V _{CC} (+5.0V)
VEE	ECL V _{EE} (-5.2/-4.5V)
VCCE	ECL Ground (0V)
D, D	Signal Input (ECL)
V _{BB}	V _{BB} Reference Output
Q0-Q7	Signal Outputs (TTL)
EN	Enable Input (ECL)
LEN	Latch Enable Input (ECL)



MC10H643 MC100H643

LOGIC DIAGRAM

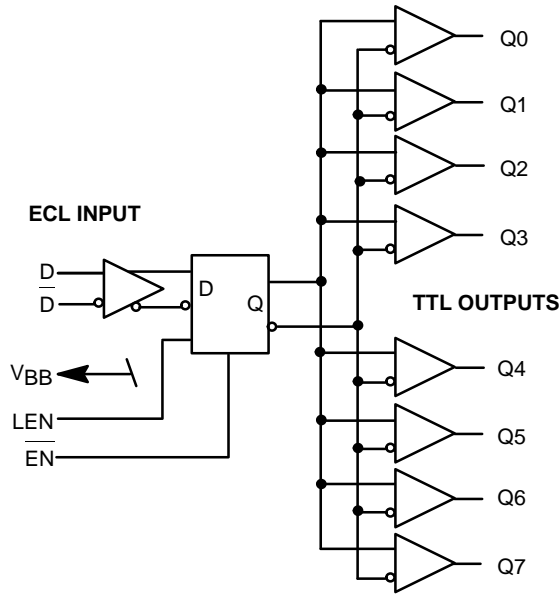

DC CHARACTERISTICS (IVT = OVT = 5.0V ±5%; VEE = -5.2V ±5% (10H Version); VEE = -4.5V ±0.3V (100H Version))

Symbol	Characteristic	0°C		25°C		85°C		Unit	Condition	
		Min	Max	Min	Max	Min	Max			
I _{EE}	Power Supply Current	ECL	-	42	-	42	-	42	mA	V _{EE} Pins
I _{CCL}		TTL	-	106	-	106	-	106	mA	Total all OVT
I _{CCH}			-	95	-	95	-	95	mA	and IVT pins

AC CHARACTERISTICS (IVT = OVT = 5.0V ±5%; VEE = -5.2V ±10% (10H); -4.5V ±0.3V (100H); V_{CCE} = GND)

Symbol	Characteristic	0°C		25°C		85°C		Unit	Condition
		Min	Max	Min	Max	Min	Max		
t _{PLH}	Propagation Delay to Output D LEN EN	4.0 3.5 3.5	5.0 5.5 5.5	4.1 3.5 3.5	5.1 5.5 5.5	4.4 3.9 3.9	5.4 5.9 5.9	ns	CL = 50pF
t _{SKEW}	Within-Device Skew	-	0.5	-	0.5		0.5	ns	Note 1
t _w	Pulse Width Out HIGH or LOW @ f _{out} = 50MHz	9.0	11.0	9.0	11.0	9.0	11.0	ns	CL = 50pF Note 2
t _s	Setup Time D	0.75	-	0.75	-	0.75	-	ns	
t _h	Hold Time D	0.75	-	0.75	-	0.75	-	ns	
t _{RR}	Recovery Time LEN EN	1.25 1.25	- -	1.25 1.25	- -	1.25 1.25	- -	ns	
t _{pw}	Minimum Pulse Width LEN EN	1.5 1.5	- -	1.5 1.5	- -	1.5 1.5	- -	ns	
t _r t _f	Rise / Fall Times 0.8 V – 2.0 V	-	1.2	-	1.2	-	1.2	ns	CL = 50pF

1. Within-Device skew defined as identical transitions on similar paths through a device.
 2. Pulse width is defined relative to 1.5V measurement points on the output waveform.

TRUTH TABLE

D	LEN	EN	Q
L	L	L	L
H	L	L	H
X	H	L	Q _O
X	X	H	L

DC CHARACTERISTICS (IVT = OVT = 5.0V ±5%; V_{EE} = -5.2V ±5% (10H Version); V_{EE} = -4.5V ±0.3V (100H Version))

Symbol	Characteristic	0°C		25°C		85°C		Unit	Condition
		Min	Max	Min	Max	Min	Max		
V _{OH}	Output HIGH Voltage	2.5 2.0	- -	2.5 2.0	- -	2.5 2.0	- -	V	I _{OH} = -3.0mA I _{OH} = -15mA
V _{OL}	Output LOW Voltage	-	0.5	-	0.5	-	0.5	V	I _{OH} = 48mA
I _{OS}	Output Short Circuit Current	-100	-225	-100	-225	-100	-225	mA	V _{OUT} = 0V

10H DC CHARACTERISTICS (IVT = OVT = 5.0V ±5%; V_{EE} = -5.2V ±5% (10H Version); V_{EE} = -4.5V ±0.3V (100H Version))

Symbol	Characteristic	0°C		25°C		85°C		Unit	Condition
		Min	Max	Min	Max	Min	Max		
I _{IH} I _{IL}	Input HIGH Current Input LOW Current	- 0.5	225 -	- 0.5	175 -	- 0.5	175 -	μA	
V _{IH} V _{IL}	Input HIGH Voltage Input LOW Voltage	-1170 -1950	-840 -1480	-1130 -1950	-810 -1480	-1070 -1950	-735 -1450	mV	
V _{BB}	Output Reference Voltage	-1380	-1270	-1350	-1250	-1310	-1190	mV	

100H DC CHARACTERISTICS (IVT = OVT = 5.0V ±5%; V_{EE} = -5.2V ±5% (10H); V_{EE} = -4.5V ±0.3V (100H))

Symbol	Characteristic	0°C		25°C		85°C		Unit	Condition
		Min	Max	Min	Max	Min	Max		
I _{IH} I _{IL}	Input HIGH Current Input LOW Current	- 0.5	225 -	- 0.5	175 -	- 0.5	175 -	μA	
V _{IH} V _{IL}	Input HIGH Voltage Input LOW Voltage	-1165 -1810	-880 -1475	-1165 -1810	-880 -1475	-1165 -1810	-880 -1475	mV	
V _{BB}	Output Reference Voltage	-1380	-1260	-1380	-1260	-1380	-1260	mV	

OUTLINE DIMENSIONS

FN SUFFIX
 PLASTIC PLCC PACKAGE
 CASE 776-02
 ISSUE D

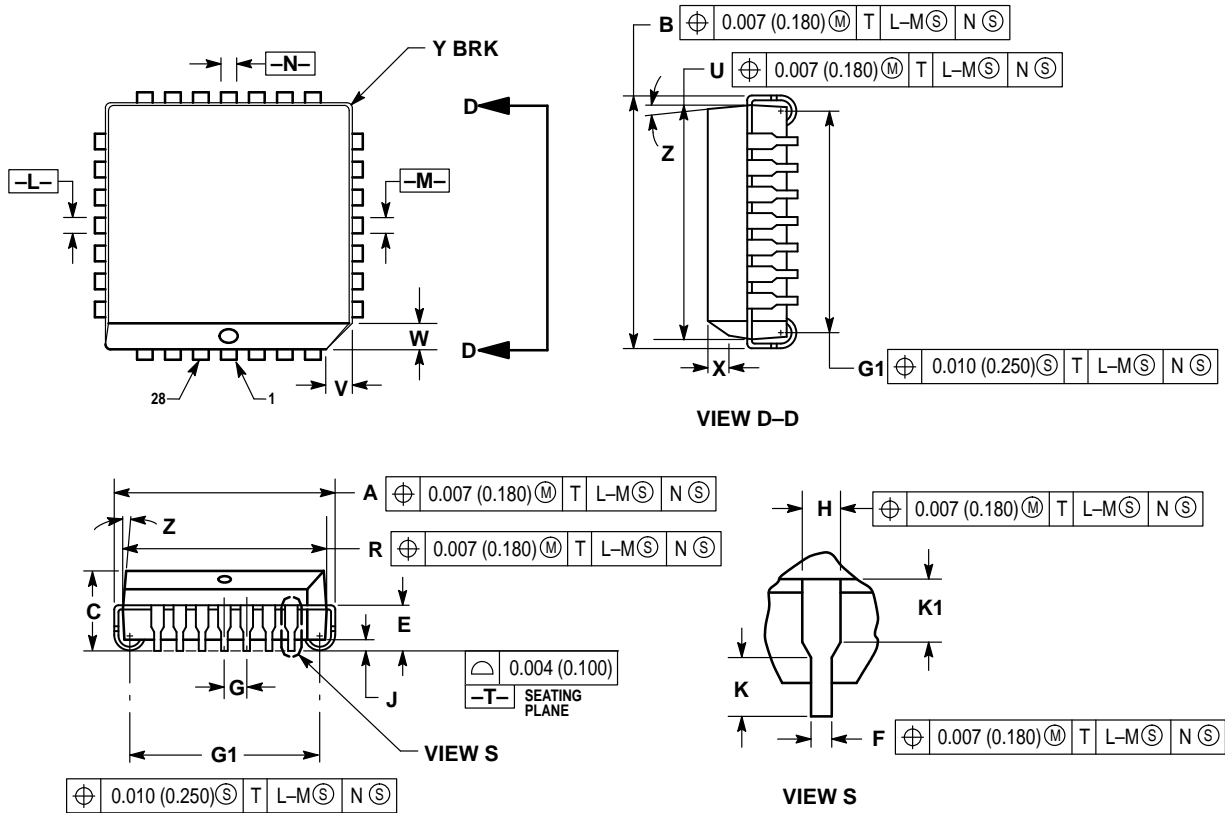

NOTES:

- DATUMS -L-, -M-, AND -N- DETERMINED WHERE TOP OF LEAD SHOULDER EXITS PLASTIC BODY AT MOLD PARTING LINE.
- DIMENSION G1, TRUE POSITION TO BE MEASURED AT DATUM -T-, SEATING PLANE.
- DIMENSIONS R AND U DO NOT INCLUDE MOLD FLASH. ALLOWABLE MOLD FLASH IS 0.010 (0.250) PER SIDE.
- DIMENSIONING AND TOLERANCING PER ANSI Y14.5M, 1982.
- CONTROLLING DIMENSION: INCH.
- THE PACKAGE TOP MAY BE SMALLER THAN THE PACKAGE BOTTOM BY UP TO 0.012 (0.300). DIMENSIONS R AND U ARE DETERMINED AT THE OUTERMOST EXTREMES OF THE PLASTIC BODY EXCLUSIVE OF MOLD FLASH, TIE BAR BURRS, GATE BURRS AND INTERLEAD FLASH, BUT INCLUDING ANY MISMATCH BETWEEN THE TOP AND BOTTOM OF THE PLASTIC BODY.
- DIMENSION H DOES NOT INCLUDE DAMBAR PROTRUSION OR INTRUSION. THE DAMBAR PROTRUSION(S) SHALL NOT CAUSE THE H DIMENSION TO BE GREATER THAN 0.037 (0.940). THE DAMBAR INTRUSION(S) SHALL NOT CAUSE THE H DIMENSION TO BE SMALLER THAN 0.025 (0.635).

DIM	INCHES		MILLIMETERS	
	MIN	MAX	MIN	MAX
A	0.485	0.495	12.32	12.57
B	0.485	0.495	12.32	12.57
C	0.165	0.180	4.20	4.57
E	0.090	0.110	2.29	2.79
F	0.013	0.019	0.33	0.48
G	0.050 BSC		1.27 BSC	
H	0.026	0.032	0.66	0.81
J	0.020	—	0.51	—
K	0.025	—	0.64	—
R	0.450	0.456	11.43	11.58
U	0.450	0.456	11.43	11.58
V	0.042	0.048	1.07	1.21
W	0.042	0.048	1.07	1.21
X	0.042	0.056	1.07	1.42
Y	—	0.020	—	0.50
Z	2°	10°	2°	10°
G1	0.410	0.430	10.42	10.92
K1	0.040	—	1.02	—

Motorola reserves the right to make changes without further notice to any products herein. Motorola makes no warranty, representation or guarantee regarding the suitability of its products for any particular purpose, nor does Motorola assume any liability arising out of the application or use of any product or circuit, and specifically disclaims any and all liability, including without limitation consequential or incidental damages. "Typical" parameters which may be provided in Motorola data sheets and/or specifications can and do vary in different applications and actual performance may vary over time. All operating parameters, including "Typicals" must be validated for each customer application by customer's technical experts. Motorola does not convey any license under its patent rights nor the rights of others. Motorola products are not designed, intended, or authorized for use as components in systems intended for surgical implant into the body, or other applications intended to support or sustain life, or for any other application in which the failure of the Motorola product could create a situation where personal injury or death may occur. Should Buyer purchase or use Motorola products for any such unintended or unauthorized application, Buyer shall indemnify and hold Motorola and its officers, employees, subsidiaries, affiliates, and distributors harmless against all claims, costs, damages, and expenses, and reasonable attorney fees arising out of, directly or indirectly, any claim of personal injury or death associated with such unintended or unauthorized use, even if such claim alleges that Motorola was negligent regarding the design or manufacture of the part. Motorola and  are registered trademarks of Motorola, Inc. Motorola, Inc. is an Equal Opportunity/Affirmative Action Employer.

How to reach us:

USA/EUROPE/Locations Not Listed: Motorola Literature Distribution;
P.O. Box 20912; Phoenix, Arizona 85036. 1-800-441-2447 or 602-303-5454

MFAX: RMFAX0@email.sps.mot.com – TOUCHTONE 602-244-6609
INTERNET: <http://Design-NET.com>

JAPAN: Nippon Motorola Ltd.; Tatsumi-SPD-JLDC, 6F Seibu-Butsuryu-Center,
3-14-2 Tatsumi Koto-Ku, Tokyo 135, Japan. 03-81-3521-8315

ASIA/PACIFIC: Motorola Semiconductors H.K. Ltd.; 8B Tai Ping Industrial Park,
51 Ting Kok Road, Tai Po, N.T., Hong Kong. 852-26629298