

## PECL/TTL-TTL 1:8 Clock Distribution Chip

The MC10H/100H646 is a single supply, low skew translating 1:8 clock driver. Devices in the Motorola H600 translator series utilize the 28-lead PLCC for optimal power pinning, signal flow through and electrical performance. The single supply H646 is similar to the H643, which is a dual supply 1:8 version of the same function.

- PECL/TTL-TTL Version of Popular ECLinPS™ E111
- Low Skew
- Guaranteed Skew Spec
- Tri-State Enable
- Differential Internal Design
- V<sub>BB</sub> Output
- Single Supply
- Extra TTL and ECL Power/Ground Pins
- Matched High and Low Output Impedance
- Meets Specifications Required to Drive the Pentium™ Microprocessor

The H646 was designed specifically to drive series terminated transmission lines. Special techniques were used to match the HIGH and LOW output impedances to about 7ohms. This simplifies the choice of the termination resistor for series terminated applications. To match the HIGH and LOW output impedances, it was necessary to remove the standard I<sub>OS</sub> limiting resistor. As a result, the user should take care in preventing an output short to ground as the part will be permanently damaged.

The H646 device meets all of the requirements for driving the 60 and 66MHz Pentium Microprocessor. The device has no PLL components, which greatly simplifies its implementation into a digital design. The eight copies of the clock allows for point-to-point clock distribution to simplify board layout and optimize signal integrity.

The H646 provides differential PECL inputs for picking up LOW skew PECL clocks from the backplane and distributing it to TTL loads on a daughter board. When used in conjunction with the MC10/100E111, very low skew, very wide clock trees can be designed. In addition, a TTL level clock input is provided for flexibility. Note that only one of the inputs can be used on a single chip. For correct operation, the unused input pins should be left open.

The Output Enable pin forces the outputs into a high impedance state when a logic 0 is applied.

The output buffers of the H646 can drive two series terminated, 50Ω transmission lines each. This capability allows the H646 to drive up to 16 different point-to-point clock loads. Refer to the Applications section for a more detailed discussion in this area.

The 10H version is compatible with MECL 10H™ ECL logic levels. The 100H version is compatible with 100K levels.

MECL 10H and ECLinPS are trademarks of Motorola, Inc. Pentium is a trademark of Intel Corporation.

**MC10H646**  
**MC100H646**

**PENTIUM**  
**MICROPROCESSOR**  
**PECL/TTL-TTL**  
**CLOCK DRIVER**

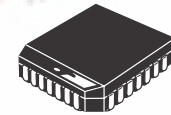

**FN SUFFIX**  
PLASTIC PACKAGE  
CASE 776-02



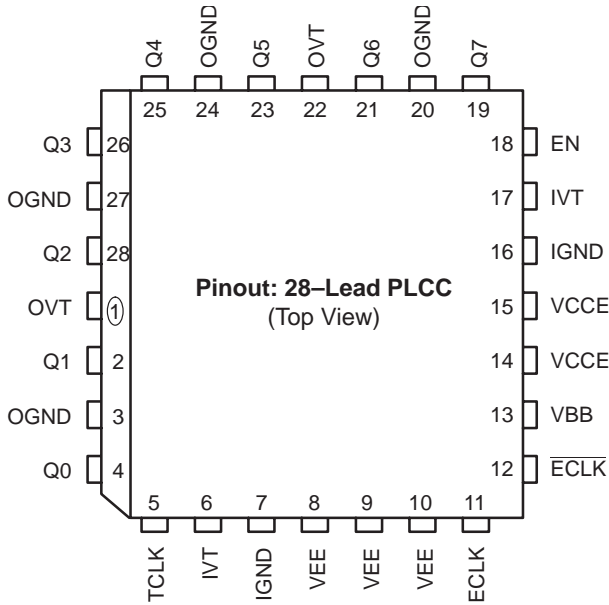

**PIN NAMES**

PIN	FUNCTION
OGND	TTL Output Ground (0V)
OVT	TTL Output V <sub>CC</sub> (+5.0V)
IGND	Internal TTL GND (0V)
IVT	Internal TTL V <sub>CC</sub> (+5.0V)
VEE	ECL V <sub>EE</sub> (0V)
VCCE	ECL Ground (5.0V)
ECLK, $\overline{\text{ECLK}}$	Differential Signal Input (PECL)
V <sub>BB</sub>	V <sub>BB</sub> Reference Output
Q0-Q7	Signal Outputs (TTL)
EN	Tri-State Enable Input (TTL)

**LOGIC DIAGRAM**

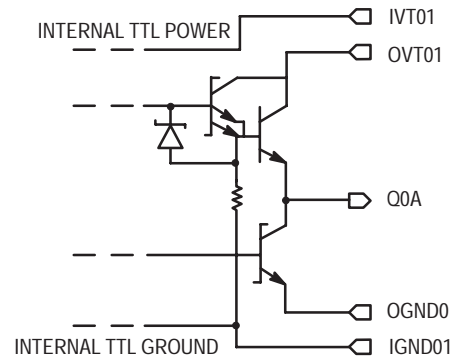
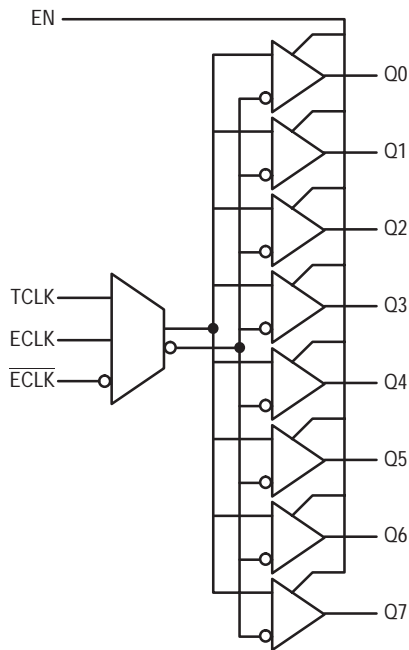

**Figure 1. Output Structure**

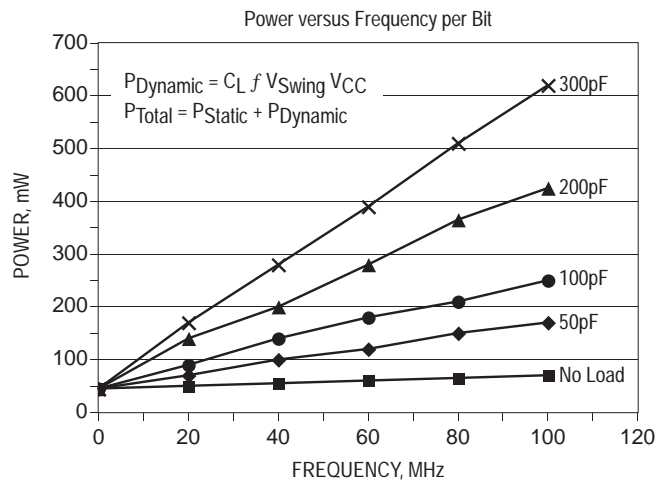

**Figure 2. Power versus Frequency (Typical)**

**TRUTH TABLE**

TCLK	ECLK	$\overline{\text{ECLK}}$	EN	Q
GND	L	H	H	L
GND	H	L	H	H
H	GND	GND	H	H
L	GND	GND	H	L
X	X	X	L	Z

L = Low Voltage Level; H = High Voltage Level; Z = Tristate

**DC CHARACTERISTICS** (IVT = OVT = VCCE = 5.0V ±5%)

Symbol	Characteristic	0°C		25°C		85°C		Unit	Condition
		Min	Max	Min	Max	Min	Max		
V <sub>OH</sub>	Output HIGH Voltage	2.6	–	2.6	–	2.6	–	V	I <sub>OH</sub> = 24mA
V <sub>OL</sub>	Output LOW Voltage	–	0.5	–	0.5	–	0.5	V	I <sub>OL</sub> = 48mA
IOS	Output Short Circuit Current	–	–	–	–	–	–	mA	See Note 1

1. The outputs must not be shorted to ground, as this will result in permanent damage to the device. The high drive outputs of this device do not include a limiting IOS resistor.

**TTL DC CHARACTERISTICS** (VT = VE = 5.0 V ±5%)

Symbol	Characteristic	0°C		25°C		85°C		Unit	Condition
		Min	Max	Min	Max	Min	Max		
V <sub>IH</sub> V <sub>IL</sub>	Input HIGH Voltage Input LOW Voltage	2.0	0.8	2.0	0.8	2.0	0.8	V	
I <sub>IH</sub>	Input HIGH Current		20 100		20 100		20 100	µA	V <sub>IN</sub> = 2.7 V V <sub>IN</sub> = 7.0 V
I <sub>IL</sub>	Input LOW Current		–0.6		–0.6		–0.6	mA	V <sub>IN</sub> = 0.5 V
V <sub>OH</sub>	Output HIGH Voltage	2.5 2.0		2.5 2.0		2.5 2.0		V	I <sub>OH</sub> = –3.0 mA I <sub>OH</sub> = –24 mA
V <sub>OL</sub>	Output LOW Voltage		0.5		0.5		0.5	V	I <sub>OL</sub> = 24 mA
V <sub>IK</sub>	Input Clamp Voltage		–1.2		–1.2		–1.2	V	I <sub>IN</sub> = –18 mA
I <sub>OS</sub>	Output Short Circuit Current	–100	–225	–100	–225	–100	–225	mA	V <sub>OUT</sub> = 0 V

**10H PECL DC CHARACTERISTICS** (IVT = OVT = VCCE = 5.0V ±5%)

Symbol	Characteristic	0°C			25°C			85°C			Unit	Notes
		Min	Typ	Max	Min	Typ	Max	Min	Typ	Max		
I <sub>IH</sub>	Input HIGH Current			225			175			175	µA	
I <sub>IL</sub>	Input LOW Current	0.5			0.5			0.5			µA	
V <sub>IH</sub>	Input HIGH Voltage	3.83		4.16	3.87		4.19	3.94		4.28	V	IVT = IVO = VCCE = 5.0V (1)
V <sub>IL</sub>	Input LOW Voltage	3.05		3.52	3.05		3.52	3.05		3.555	V	IVT = IVO = VCCE = 5.0V (1)
V <sub>BB</sub>	Output Reference Voltage	3.62		3.73	3.65		3.75	3.69		3.81	V	IVT = IVO = VCCE = 5.0V (1)

**100H PECL DC CHARACTERISTICS** (IVT = OVT = VCCE = 5.0V ±5%)

Symbol	Characteristic	0°C			25°C			85°C			Unit	Notes
		Min	Typ	Max	Min	Typ	Max	Min	Typ	Max		
I <sub>IH</sub>	Input HIGH Current			225			175			175	µA	
I <sub>IL</sub>	Input LOW Current	0.5			0.5			0.5			µA	
V <sub>IH</sub>	Input HIGH Voltage	3.835		4.12	3.835		4.12	3.835		3.835	V	IVT = IVO = VCCE = 5.0V (1)
V <sub>IL</sub>	Input LOW Voltage	3.19		3.525	3.19		3.525	3.19		3.525	V	IVT = IVO = VCCE = 5.0V (1)
V <sub>BB</sub>	Output Reference Voltage	3.62		3.74	3.62		3.74	3.62		3.74	V	IVT = IVO = VCCE = 5.0V (1)

1. ECL V<sub>IH</sub>, V<sub>IL</sub> and V<sub>BB</sub> are referenced to VCCE and will vary 1:1 with the power supply. The levels shown are for IVT = IVO = VCCE = 5.0V

**DC CHARACTERISTICS** (IVT = OVT = VCCE = 5.0V ±5%)

Symbol	Characteristic	0°C		25°C			85°C		Unit	Condition
		Min	Max	Min	Typ	Max	Min	Max		
I <sub>CC</sub> L	Power Supply Current		185		166	185		185	mA	Total all OVT, IVT, and VCCE pins
I <sub>CC</sub> H			175		154	175		175	mA	
I <sub>CC</sub> Z				210			210		210	

**AC CHARACTERISTICS** (IVT = OVT = VCCE = 5.0V ±5%)

Symbol	Characteristic	0°C		25°C		85°C		Unit	Condition	
		Min	Max	Min	Max	Min	Max			
t <sub>PLH</sub>	Propagation Delay	ECLK to Q TCLK to Q	4.8 5.1	5.8 6.4	5.0 5.3	6.0 6.4	5.6 5.7	6.6 7.0	ns	
t <sub>PHL</sub>	Propagation Delay	ECLK to Q TCLK to Q	4.4 4.7	5.4 6.0	4.4 4.8	5.4 5.9	4.8 5.2	5.8 6.5	ns	
t <sub>SK(O)</sub>	Output Skew	Q0, Q3, Q4, Q7 Q1, Q2, Q5 Q0-Q7		350 350 500		350 350 500		350 350 500	ps	Note 1, 6
t <sub>SK(PR)</sub>	Process Skew	ECLK to Q TCLK to Q		1.0 1.3		1.0 1.1		1.0 1.3	ns	Note 2, 6
t <sub>SK(P)</sub>	Pulse Skew	Δt <sub>PLH</sub> - t <sub>PHL</sub>		1.0		1.0		1.0	ns	
t <sub>r</sub> , t <sub>f</sub>	Rise/Fall Time		0.3	1.5	0.3	1.5	0.3	1.5	ns	
t <sub>PW</sub>	Output Pulse Width	66MHz @ 2.0V 66MHz @ 0.8V 60MHz @ 2.0V 60MHz @ 0.8V	5.5 5.5 6.0 6.0		5.5 5.5 6.0 6.0		5.5 5.5 6.0 6.0		ns	Note 3, 6
t <sub>Stability</sub>	Clock Stability			±75		±75		±75	ps	Note 4, 6
F <sub>MAX</sub>	Maximum Input Frequency			80		80		80	MHz	Note 5, 6

1. Output skew defined for identical output transitions.
2. Process skew is valid for V<sub>CC</sub> = 5.0V ±5%.
3. Parameters guaranteed by t<sub>SK(P)</sub> and t<sub>r</sub>, t<sub>f</sub> specification limits.
4. Clock stability is the period variation between two successive rising edges.
5. For series terminated lines. See Applications section for F<sub>MAX</sub> enhancement techniques.
6. All AC specifications tested driving 50Ω series terminated transmission lines at 80MHz.

## OUTLINE DIMENSIONS

### FN SUFFIX PLASTIC PLCC PACKAGE CASE 776-02 ISSUE D

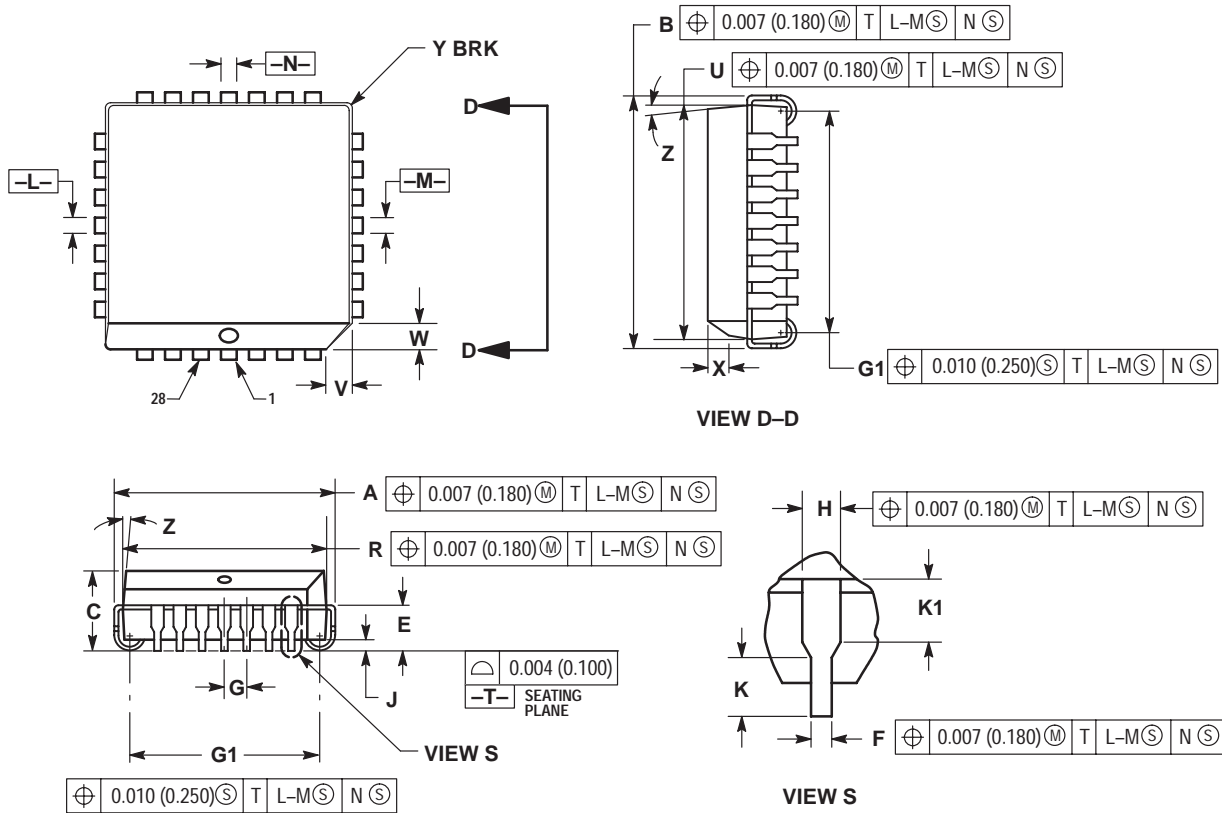

**NOTES:**

1. DATUMS  $-L-$ ,  $-M-$ , AND  $-N-$  DETERMINED WHERE TOP OF LEAD SHOULDER EXITS PLASTIC BODY AT MOLD PARTING LINE.
2. DIMENSION  $G1$ , TRUE POSITION TO BE MEASURED AT DATUM  $-T-$ , SEATING PLANE.
3. DIMENSIONS  $R$  AND  $U$  DO NOT INCLUDE MOLD FLASH. ALLOWABLE MOLD FLASH IS 0.010 (0.250) PER SIDE.
4. DIMENSIONING AND TOLERANCING PER ANSI Y14.5M, 1982.
5. CONTROLLING DIMENSION: INCH.
6. THE PACKAGE TOP MAY BE SMALLER THAN THE PACKAGE BOTTOM BY UP TO 0.012 (0.300). DIMENSIONS  $R$  AND  $U$  ARE DETERMINED AT THE OUTERMOST EXTREMES OF THE PLASTIC BODY EXCLUSIVE OF MOLD FLASH, TIE BAR BURRS, GATE BURRS AND INTERLEAD FLASH, BUT INCLUDING ANY MISMATCH BETWEEN THE TOP AND BOTTOM OF THE PLASTIC BODY.
7. DIMENSION  $H$  DOES NOT INCLUDE DAMBAR PROTRUSION OR INTRUSION. THE DAMBAR PROTRUSION(S) SHALL NOT CAUSE THE  $H$  DIMENSION TO BE GREATER THAN 0.037 (0.940). THE DAMBAR INTRUSION(S) SHALL NOT CAUSE THE  $H$  DIMENSION TO BE SMALLER THAN 0.025 (0.635).

DIM	INCHES		MILLIMETERS	
	MIN	MAX	MIN	MAX
A	0.485	0.495	12.32	12.57
B	0.485	0.495	12.32	12.57
C	0.165	0.180	4.20	4.57
E	0.090	0.110	2.29	2.79
F	0.013	0.019	0.33	0.48
G	0.050 BSC		1.27 BSC	
H	0.026	0.032	0.66	0.81
J	0.020	---	0.51	---
K	0.025	---	0.64	---
R	0.450	0.456	11.43	11.58
U	0.450	0.456	11.43	11.58
V	0.042	0.048	1.07	1.21
W	0.042	0.048	1.07	1.21
X	0.042	0.056	1.07	1.42
Y	---	0.020	---	0.50
Z	2°		10°	
G1	0.410	0.430	10.42	10.92
K1	0.040	---	1.02	---

Motorola reserves the right to make changes without further notice to any products herein. Motorola makes no warranty, representation or guarantee regarding the suitability of its products for any particular purpose, nor does Motorola assume any liability arising out of the application or use of any product or circuit, and specifically disclaims any and all liability, including without limitation consequential or incidental damages. "Typical" parameters which may be provided in Motorola data sheets and/or specifications can and do vary in different applications and actual performance may vary over time. All operating parameters, including "Typicals" must be validated for each customer application by customer's technical experts. Motorola does not convey any license under its patent rights nor the rights of others. Motorola products are not designed, intended, or authorized for use as components in systems intended for surgical implant into the body, or other applications intended to support or sustain life, or for any other application in which the failure of the Motorola product could create a situation where personal injury or death may occur. Should Buyer purchase or use Motorola products for any such unintended or unauthorized application, Buyer shall indemnify and hold Motorola and its officers, employees, subsidiaries, affiliates, and distributors harmless against all claims, costs, damages, and expenses, and reasonable attorney fees arising out of, directly or indirectly, any claim of personal injury or death associated with such unintended or unauthorized use, even if such claim alleges that Motorola was negligent regarding the design or manufacture of the part. Motorola and  are registered trademarks of Motorola, Inc. Motorola, Inc. is an Equal Opportunity/Affirmative Action Employer.

**How to reach us:**

**USA/EUROPE/Locations Not Listed:** Motorola Literature Distribution;  
P.O. Box 5405; Denver, Colorado 80217. 303-675-2140 or 1-800-441-2447

**Mfax™:** RMFAX0@email.sps.mot.com – TOUCHTONE 602-244-6609  
**INTERNET:** <http://www.mot.com/sp/>

**JAPAN:** Nippon Motorola Ltd.; Tatsumi-SPD-JLDC, 6F Seibu-Butsuryu-Center,  
3-14-2 Tatsumi Koto-Ku, Tokyo 135, Japan. 81-3-3521-8315

**ASIA/PACIFIC:** Motorola Semiconductors H.K. Ltd.; 8B Tai Ping Industrial Park,  
51 Ting Kok Road, Tai Po, N.T., Hong Kong. 852-26629298