

July 1994

Video Operational Amplifier

Features

- This Circuit is Processed in Accordance to MIL-STD-883 and is Fully Conformant Under the Provisions of Paragraph 1.2.1.
- Wide Unity Gain Bandwidth 45MHz (Min)
- High Slew Rate 100V/μs (Min)
- Low Supply Current 12mA (Max)
- Differential Gain Error 0.04dB (Max)
- Differential Phase Error 0.11 Deg. (Max)
- Gain Flatness at 3.58MHz or 4.43MHz ... 0.15dB (Max)
- Fast Settling Time (10V to 0.1%) 120ns (Typ)

Applications

- Video Systems
- Video Test Equipment
- Radar Displays
- Imaging Systems
- Pulse Amplifiers
- Signal Conditioning Circuits
- Data Acquisition Systems

Description

The HA-2544/883 is a fast, unity gain stable, monolithic op amp designed to meet the needs required for accurate reproduction of video or high speed signals. It offers high voltage gain (3.5kV/V min, 6kV/V typ), wide unity gain bandwidth of 45MHz minimum and phase margin of 65 degrees (open loop). Built from high quality Dielectric Isolation, the HA-2544/883 is another addition to the Intersil series of high speed, wideband op amps, and offers true video performance combined with the versatility of an op amp.

The primary features of the HA-2544/883, include wide bandwidth, 150V/μs (typ) slew rate, < 0.04dB differential gain error, < 0.11 degrees differential phase error and gain flatness of just 0.15dB at 3.58MHz and 4.43MHz, therefore proving to be sufficient for video amplification. High performance and low power requirements are met with a supply current of only 10mA typically and 12mA over the full temperature range.

Uses of the HA-2544/883 range from video test equipment guidance systems, radar displays and other precise imaging systems where stringent gain and phase requirements have previously been met with costly hybrids and discrete circuitry. The HA-2544/883 will also be used in non-video systems requiring high speed signal conditioning such as data acquisition systems, medical electronics, specialized instrumentation and communication systems.

Ordering Information

PART NUMBER	TEMPERATURE RANGE	PACKAGE
HA2-2544/883	-55°C to +125°C	8 Pin Can
HA4-2544/883	-55°C to +125°C	20 Lead Ceramic LCC
HA7-2544/883	-55°C to +125°C	8 Lead CerDIP

Pinouts

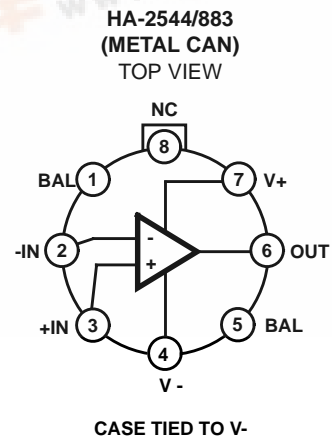
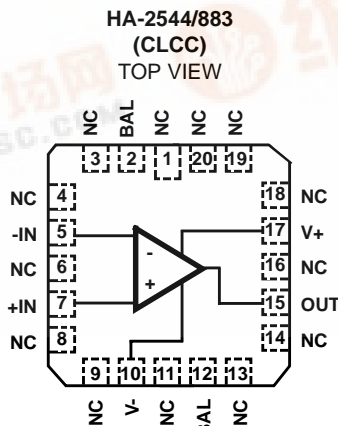
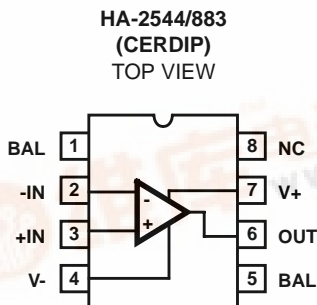

Specifications HA-2544/883

Absolute Maximum Ratings

Voltage Between V+ and V- Terminals	35V
Differential Input Voltage (Note 2)	6V
Voltage at Either Input Terminal	V+ to V-
Peak Output Current (< 10% Duty Cycle)	40mA
Junction Temperature (T _J)	+175°C
Storage Temperature Range	-65°C to +150°C
ESD Rating	<2000V
Lead Temperature (Soldering 10s)	+300°C

Thermal Information

Thermal Resistance	θ_{JA}	θ_{JC}
CerDIP Package	115°C/W	28°C/W
Ceramic LCC Package	65°C/W	15°C/W
Metal Can Package	155°C/W	67°C/W
Package Power Dissipation Limit at +75°C for T _J ≤ +175°C		
CerDIP Package	870mW	
Ceramic LCC Package	1.54W	
Metal Can Package	645mW	
Package Power Dissipation Derating Factor Above +75°C		
CerDIP Package	8.7mW/°C	
Ceramic LCC Package	15.4mW/°C	
Metal Can Package	6.5mW/°C	

CAUTION: Stresses above those listed in "Absolute Maximum Ratings" may cause permanent damage to the device. This is a stress only rating and operation of the device at these or any other conditions above those indicated in the operational sections of this specification is not implied.

Operating Conditions

Operating Temperature Range	-55°C to +125°C	V _{INCM} ≤ 1/2 (V+ - V-)
Operating Supply Voltage	±15V	R _L ≥ 2kΩ

TABLE 1. DC ELECTRICAL PERFORMANCE CHARACTERISTICS

Device Tested at: V_{SUPPLY} = ±15V, R_{SOURCE} = 10Ω, R_{LOAD} = 500kΩ, C_{LOAD} ≤ 10pF, V_{OUT} = 0V, Unless Otherwise Specified.

PARAMETERS	SYMBOL	CONDITIONS	GROUP A SUBGROUPS	TEMPERATURE	LIMITS		UNITS
					MIN	MAX	
Input Offset Voltage	V _{IO}	V _{CM} = 0V	1	+25°C	-15	15	mV
			2, 3	+125°C, -55°C	-20	20	mV
Input Bias Current	+I _B	V _{CM} = 0V, +R _S = 1kΩ, -R _S = 10Ω	1	+25°C	-15	15	μA
			2, 3	+125°C, -55°C	-20	20	μA
	-I _B	V _{CM} = 0V, +R _S = 10Ω, -R _S = 1kΩ	1	+25°C	-15	15	μA
			2, 3	+125°C, -55°C	-20	20	μA
Input Offset Current	I _{IO}	V _{CM} = 0V, +R _S = 1kΩ, -R _S = 1kΩ	1	+25°C	-2	2	μA
			2, 3	+125°C, -55°C	-3	3	μA
Common Mode Range	+CMR	V+ = 5V, V- = -25V	1	+25°C	10	-	V
			2, 3	+125°C, -55°C	10	-	V
	-CMR	V+ = 25V, V- = -5V	1	+25°C	-	-10	V
			2, 3	+125°C, -55°C	-	-10	V
Large Signal Voltage Gain	+A _{VOL}	V _{OUT} = 0V and +8V, R _L = 1kΩ	4	+25°C	3.5	-	kV/V
			5, 6	+125°C, -55°C	2.5	-	kV/V
	-A _{VOL}	V _{OUT} = 0V and -8V, R _L = 1kΩ	4	+25°C	3.5	-	kV/V
			5, 6	+125°C, -55°C	2.5	-	kV/V
Common Mode Rejection Ratio	+CMRR	ΔV _{CM} = +10V, V+ = +5V, V- = -25V, V _{OUT} = -10V	1	+25°C	75	-	dB
			2, 3	+125°C, -55°C	75	-	dB
	-CMRR	ΔV _{CM} = -10V, V+ = +25V, V- = -5V, V _{OUT} = +10V	1	+25°C	75	-	dB
			2, 3	+125°C, -55°C	75	-	dB
Output Voltage Swing	+V _{OUT}	R _L = 1kΩ	1	+25°C	10	-	V
			2, 3	+125°C, -55°C	10	-	V
	-V _{OUT}	R _L = 1kΩ	1	+25°C	-	-10	V
			2, 3	+125°C, -55°C	-	-10	V

Specifications HA-2544/883

TABLE 1. DC ELECTRICAL PERFORMANCE CHARACTERISTICS (Continued)

Device Tested at: $V_{SUPPLY} = \pm 15V$, $R_{SOURCE} = 10\Omega$, $R_{LOAD} = 500k\Omega$, $C_{LOAD} \leq 10pF$, $V_{OUT} = 0V$, Unless Otherwise Specified.

PARAMETERS	SYMBOL	CONDITIONS	GROUP A SUBGROUPS	TEMPERATURE	LIMITS		UNITS
					MIN	MAX	
Output Current	+I _{OUT}	V _{OUT} = -9V	1	+25°C	25	-	mA
	-I _{OUT}	V _{OUT} = +9V	1	+25°C	-	-25	mA
Quiescent Power Supply Current	+I _{CC}	V _{OUT} = 0V, I _{OUT} = 0mA	1	+25°C	-	12	mA
			2, 3	+125°C, -55°C	-	12	mA
	-I _{CC}	V _{OUT} = 0V, I _{OUT} = 0mA	1	+25°C	-12	-	mA
			2, 3	+125°C, -55°C	-12	-	mA
Power Supply Rejection Ratio	+PSRR	$\Delta V_{SUP} = 10V$, V ₊ = +10V, V ₋ = -15V, V ₊ = +20V, V ₋ = -15V	1	+25°C	70	-	dB
			2, 3	+125°C, -55°C	70	-	dB
	-PSRR	$\Delta V_{SUP} = 10V$, V ₊ = +15V, V ₋ = -10V, V ₊ = +15V, V ₋ = -20V	1	+25°C	70	-	dB
			2, 3	+125°C, -55°C	70	-	dB
Offset Voltage Adjustment	+V _{IOAdj}	Note 1	1	+25°C	V _{IO} -1	-	mV
	-V _{IOAdj}	Note 1	1	+25°C	V _{IO} +1	-	mV

NOTE:

- Offset adjustment range is [V_{IO}(Measured) ±1mV] minimum referred to output. This test is for functionality only to assure adjustment through 0V.
- To achieve optimum AC performance, the input stage was designed without protective diode clamps. Exceeding the maximum differential input voltage results in reverse breakdown to the base-emitter junction of the input transistors and probable degradation of the input parameters especially V_{OS}, I_{OS} and Noise.

TABLE 2. AC ELECTRICAL PERFORMANCE CHARACTERISTICS

Device Tested at: $V_{SUPPLY} = \pm 15V$, $R_{SOURCE} = 100\Omega$, $R_{LOAD} = 1k\Omega$, $C_{LOAD} = 10pF$, $V_{OUT} = 1V/V$, Unless Otherwise Specified.

PARAMETERS	SYMBOL	CONDITIONS	GROUP A SUBGROUPS	TEMPERATURE	LIMITS		UNITS
					MIN	MAX	
Slew Rate	+SR	V _{OUT} = -3V to +3V	7	+25°C	100	-	V/μs
	-SR	V _{OUT} = +3V to -3V	7	+25°C	100	-	V/μs

TABLE 3. ELECTRICAL PERFORMANCE CHARACTERISTICS

Device Characterized at: $V_{SUPPLY} = \pm 15V$, $R_{LOAD} = 1k\Omega$, $C_{LOAD} = 10pF$, $A_V = 1V/V$, Unless Otherwise Specified.

PARAMETERS	SYMBOL	CONDITIONS	NOTES	TEMPERATURE	LIMITS		UNITS
					MIN	MAX	
Differential Gain	dA _V	R _S = 50Ω, R _L = 1kΩ, f _O = 3.58MHz and 4.43MHz	1, 5, 6, 8	+25°C	-	0.04	dB
Differential Phase	d∅	R _S = 50Ω, R _L = 1kΩ, f _O = 3.58MHz and 4.43MHz	1, 6, 8	+25°C	-	0.11	Degrees
Unity Gain Bandwidth	UGBW	V _O = 200mV _{RMS} , f at -3dB	1	+25°C	45	-	MHz
Gain Flatness	ΔA _V	V _O = 200mV _{RMS} , f _O = 5MHz	1, 6	+25°C	-0.15	0.15	dB
		V _O = 200mV _{RMS} , f _O = 10MHz	1, 6	+25°C	-0.35	0.35	dB

Specifications HA-2544/883

TABLE 3. ELECTRICAL PERFORMANCE CHARACTERISTICS (Continued)

Device Characterized at: $V_{SUPPLY} = \pm 15V$, $R_{LOAD} = 1k\Omega$, $C_{LOAD} = 10pF$, $A_V = 1V/V$, Unless Otherwise Specified.

PARAMETERS	SYMBOL	CONDITIONS	NOTES	TEMPERATURE	LIMITS		UNITS
					MIN	MAX	
Full Power Bandwidth	FPBW	$V_{PEAK} = 1V$	1, 2	+25°C	15.9	-	MHz
		$V_{PEAK} = 5V$	1, 2	+25°C	3.2	-	MHz
Minimum Closed Loop Stable Gain	CLSG	$R_L = 1k\Omega$, $C_L \leq 1pF$	1	-55°C to +125°C	1	-	V/V
Rise and Fall Time	T_R	$V_{OUT} = 0V$ to +200mV	1, 4	+25°C	-	15	ns
	T_F	$V_{OUT} = 0V$ to -200mV	1, 4	+25°C	-	15	ns
Overshoot	+OS	$V_{OUT} = 0V$ to +200mV	1	+25°C	-	20	%
	-OS	$V_{OUT} = 0V$ to -200mV	1	+25°C	-	20	%
Settling Time	T_S	Open Loop	1	+25°C	-	150	%
Output Resistance	R_{OUT}	Open Loop	1	+25°C	-	40	Ω
Quiescent Power Consumption	PC	$V_{OUT} = 0V$, $I_{OUT} = 0mA$	1, 3	-55°C to +125°C	-	360	mW

NOTES:

- Parameters listed in Table 3 are controlled via design or process parameters and are not directly tested at final production. These parameters are lab characterized upon initial design release, or upon design changes. These parameters are guaranteed by characterization based upon data from multiple production runs which reflect lot to lot and within lot variation.
- Full Power Bandwidth guarantee based on Slew Rate measurement using $FPBW = \text{Slew Rate}/(2\pi V_{PEAK})$.
- Quiescent Power Consumption based upon Quiescent Supply Current test maximum. (No load on outputs.)
- Measured between 10% and 90% points.
- $A_D(\%) = \left[\frac{A_D(\text{dB})}{20} - 1 \right] \times 100$
- The video parameter specifications will degrade as the output load resistance decreases.
- C-L Gain and C-L Delay were less than the resolution of the test equipment used which is 0.1dB and 7ns, respectively.
- Test signal used is 200mV_{RMS} at each frequency on a 0 and 1 volt offset. For adequate test repeatability, a minimum warm-up of 2 minutes is suggested.

TABLE 4. ELECTRICAL TEST REQUIREMENTS

MIL-STD-883 TEST REQUIREMENTS	SUBGROUPS (SEE TABLES 1 AND 2)
Interim Electrical Parameters (Pre Burn-In)	1
Final Electrical Test Parameters	1 (Note 1), 2, 3, 4, 5, 6, 7
Group A Test Requirements	1, 2, 3, 4, 5, 6, 7
Groups C and D Endpoints	1

NOTE:

- PDA applies to Subgroup 1 only.

HA-2544/883

Die Characteristics

DIE DIMENSIONS:

80 x 64 x 19 mils \pm 1 mils

2030 x 1630 x 483 μ m \pm 25.4 μ m

METALLIZATION:

Type: Al, 1% Cu

Thickness: 16k \AA \pm 2k \AA

GLASSIVATION:

Type: Nitride (Si₃N₄) over Silox (SiO₂, 5% Phos.)

Silox Thickness: 12k \AA \pm 2k \AA

Nitride Thickness: 3.5k \AA \pm 1.5k \AA

WORST CASE CURRENT DENSITY:

7.0 x 10⁴ A/cm²

SUBSTRATE POTENTIAL (Powered Up): V-

TRANSISTOR COUNT: 44

PROCESS: Bipolar Dielectric Isolation

Metallization Mask Layout

HA-2544/883

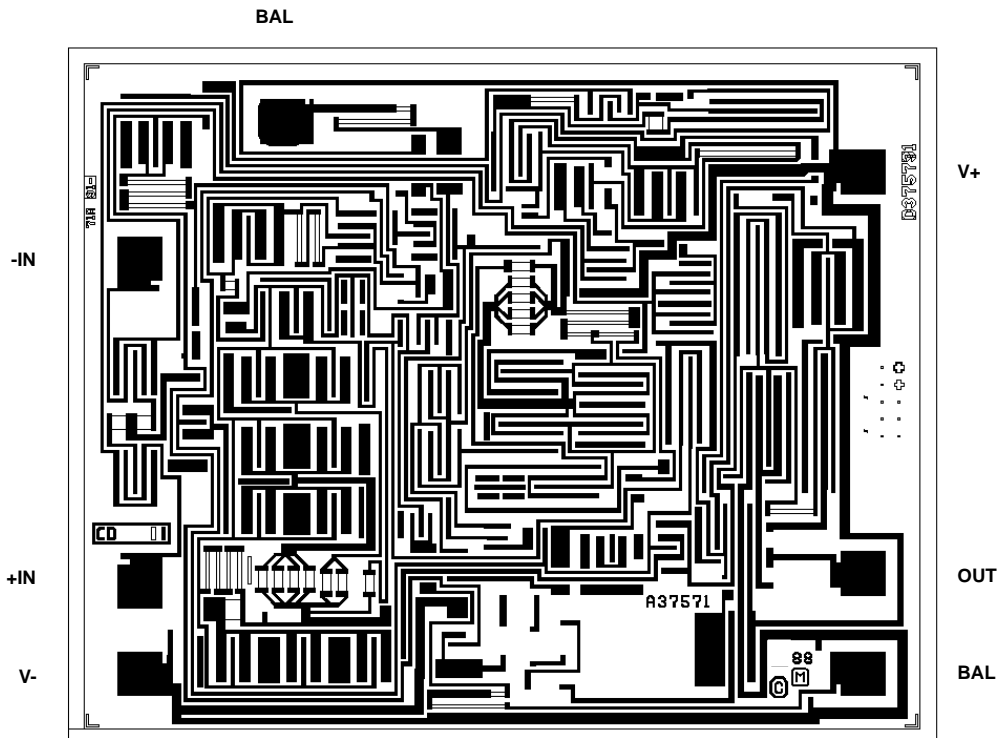

All Intersil semiconductor products are manufactured, assembled and tested under **ISO9000** quality systems certification.

Intersil products are sold by description only. Intersil Corporation reserves the right to make changes in circuit design and/or specifications at any time without notice. Accordingly, the reader is cautioned to verify that data sheets are current before placing orders. Information furnished by Intersil is believed to be accurate and reliable. However, no responsibility is assumed by Intersil or its subsidiaries for its use; nor for any infringements of patents or other rights of third parties which may result from its use. No license is granted by implication or otherwise under any patent or patent rights of Intersil or its subsidiaries.

For information regarding Intersil Corporation and its products, see web site <http://www.intersil.com>