

4MHz, High Supply Voltage Operational Amplifiers

HA-2640 and HA-2645 are monolithic operational amplifiers which are designed to deliver unprecedented dynamic specifications for a high voltage internally compensated device. These dielectrically isolated devices offer very low values for offset voltage and offset current coupled with large output voltage swing and common mode input voltage.

For maximum reliability, these amplifiers offer unconditional output overload protection through current limiting and a chip temperature sensing circuit. This sensing device turns the amplifier "off", when the chip reaches a certain temperature level.

These amplifiers deliver $\pm 35V$ common mode input voltage range, $\pm 35V$ output voltage swing, and up to $\pm 40V$ supply range for use in such designs as regulators, power supplies, and industrial control systems. 4MHz gain bandwidth and $5V/\mu s$ slew rate make these devices excellent components for high performance signal conditioning applications. Outstanding input and output voltage swings coupled with a low 5nA offset current make these amplifiers excitation designs.

Features

- Output Voltage Swing $\pm 35V$
- Supply Voltage $\pm 10V$ to $\pm 40V$
- Offset Current 5nA
- Bandwidth 4MHz
- Slew Rate $5V/\mu s$
- Common Mode Input Voltage Range $\pm 35V$
- Output Overload Protection

Applications

- Industrial Control Systems
- Power Supplies
- High Voltage Regulators
- Resolver Excitation
- Signal Conditioning

Ordering Information

PART NUMBER	TEMP. RANGE (°C)	PACKAGE	PKG. NO.
HA2-2640-2	-55 to 125	8 Pin Metal Can	T8.C
HA2-2645-5	0 to 75	8 Pin Metal Can	T8.C
HA7-2640-2	-55 to 125	8 Ld CERDIP	F8.3A
HA7-2645-5	0 to 75	8 Ld CERDIP	F8.3A

Pinouts

HA-2640/2645
(CERDIP)
TOP VIEW

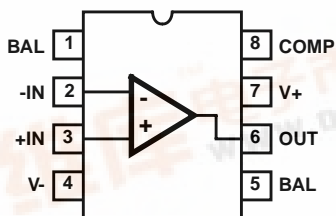

HA-2640/2645
(METAL CAN)
TOP VIEW

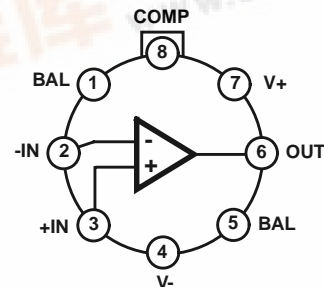

(TO-99 CASE VOLTAGE = FLOATING)



HA-2640, HA-2645

Absolute Maximum Ratings

Voltage Between V+ and V- Terminals 100V
 Differential Input Voltage Range 37V
 Output Current Full Short Circuit Protection

Operating Conditions

Temperature Range
 HA-2640-2 -55°C to 125°C
 HA-2645-5 0°C to 75°C

CAUTION: Stresses above those listed in "Absolute Maximum Ratings" may cause permanent damage to the device. This is a stress only rating and operation of the device at these or any other conditions above those indicated in the operational sections of this specification is not implied.

NOTE:

1. θ_{JA} is measured with the component mounted on an evaluation PC board in free air.

Thermal Information

Thermal Resistance (Typical, Note 1) θ_{JA} (°C/W) θ_{JC} (°C/W)
 CERDIP Package 135 50
 Metal Can Package 165 80
 Maximum Junction Temperature 175°C
 Maximum Storage Temperature Range -65°C to 150°C
 Maximum Lead Temperature (Soldering 10s) 300°C

Electrical Specifications $V_{SUPPLY} = \pm 40V$, $R_L = 5k\Omega$, Unless Otherwise Specified

PARAMETER	TEST CONDITIONS	TEMP (°C)	HA-2640-2 -55°C TO 125°C			HA-2645-5 0°C TO 75°C			UNITS
			MIN	TYP	MAX	MIN	TYP	MAX	
INPUT CHARACTERISTICS									
Offset Voltage		25	-	2	4	-	2	6	mV
		Full		-	6	-	-	7	mV
Average Offset Voltage Drift		Full	-	15	-	-	15	-	$\mu V/^\circ C$
Bias Current		25	-	10	25	-	12	30	nA
		Full	-	-	50	-	-	50	nA
Offset Current		25	-	5	12	-	15	30	nA
		Full	-	-	35	-	-	50	nA
Input Resistance (Note 2)		25	50	250	-	40	200	-	M Ω
Common Mode Range		Full	± 35	-	-	± 35	-	-	V
TRANSFER CHARACTERISTICS									
Large Signal Voltage Gain	$V_{OUT} = \pm 30V$	25	100	200	-	100	200	-	kV/V
		Full	75	-	-	75	-	-	kV/V
Common Mode Rejection Ratio	$V_{CM} = \pm 20V$	Full	80	100	-	74	100	-	dB
Minimum Stable Gain		25	1	-	-	1	-	-	V/V
Unity Gain Bandwidth	$V_{OUT} = 90mV$	25	-	4	-	-	4	-	MHz
OUTPUT CHARACTERISTICS									
Output Voltage Swing		Full	± 35	-	-	± 35	-	-	V
Output Current	$R_L = 1k\Omega$	25	± 12	± 15	-	± 10	± 12	-	mA
Output Resistance	Open Loop	25	-	500	-	-	500	-	Ω
Full Power Bandwidth (Note 3)	$V_{OUT} = \pm 35V$	25	-	23	-	-	23	-	kHz
TRANSIENT RESPONSE $A_V = +1$, $C_L = 50pF$, $R_L = 5k\Omega$									
Rise Time	$V_{OUT} = \pm 200mV$	25	-	60	135	-	60	135	ns
Overshoot	$V_{OUT} = \pm 200mV$	25	-	15	30		15	40	%
Slew Rate		25	± 3	± 5	-	± 2.5	± 5	-	V/ μs
POWER SUPPLY CHARACTERISTICS									
Supply Current		25	-	3.2	3.8	-	3.2	4.5	mA
Supply Voltage Range		Full	± 10	-	± 40	± 10	-	± 40	V
Power Supply Rejection Ratio	$V_S = \pm 10V$ to $\pm 40V$	Full	80	90	-	74	90	-	dB

NOTES:

2. This parameter is based upon design calculations.
3. Full Power Bandwidth guaranteed based upon slew rate measurement: $FPBW = S.R./2\pi V_{PEAK}$; $V_{PEAK} = 35V$.

HA-2640, HA-2645

Schematic Diagram

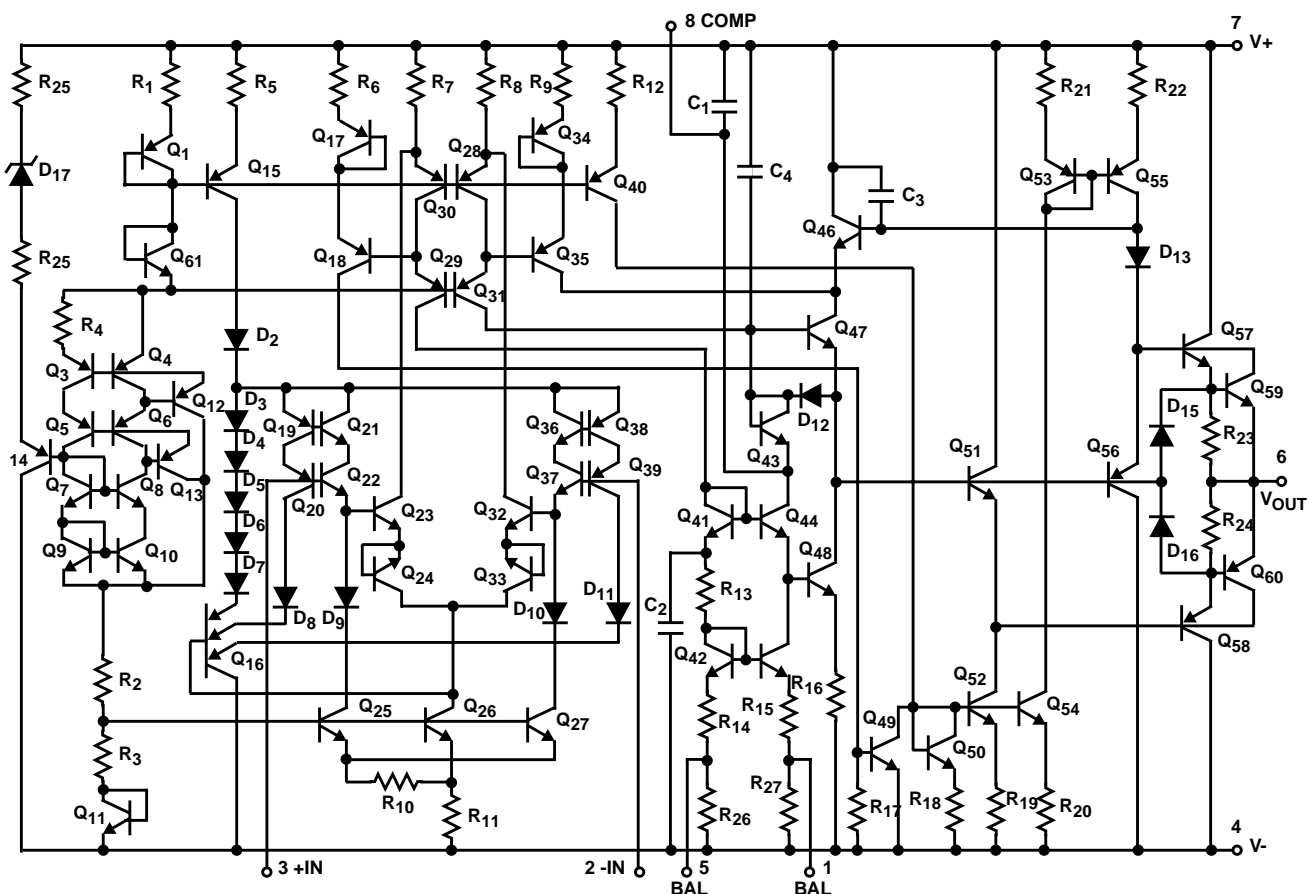

Test Circuits and Waveform

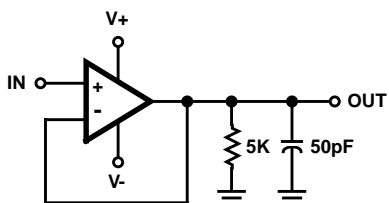
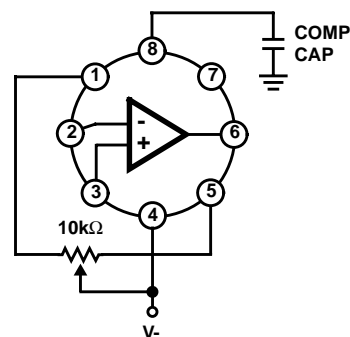

FIGURE 1. SLEW RATE AND TRANSIENT RESPONSE TEST CIRCUIT



NOTE: Tested offset adjustment range is $|V_{OS} + 1mV|$ minimum referred to output. Typical range is $\pm 20mV$ with $R_T = 10k\Omega$.

FIGURE 2. SUGGESTED V_{OS} ADJUSTMENT AND COMPENSATION HOOK UP

Test Circuits and Waveform (Continued)

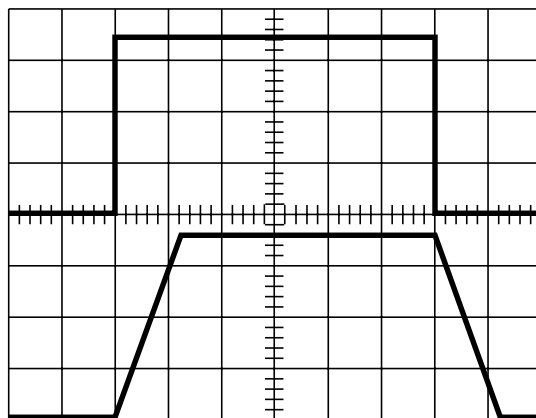

Vertical = 10V/Div., Horizontal = 5µs/Div.

NOTE: $R_L = 5k\Omega$, $C_L = 50pF$, $T_A = 25^\circ C$, $V_S = \pm 40V$

FIGURE 3. VOLTAGE FOLLOWER PULSE RESPONSE

Typical Performance Curves $V_S = \pm 40V$, $T_A = 25^\circ C$, Unless Otherwise Specified

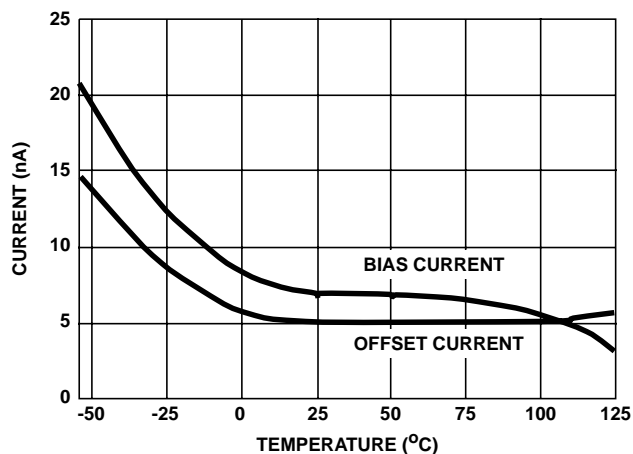

FIGURE 4. INPUT BIAS AND OFFSET CURRENT vs TEMPERATURE

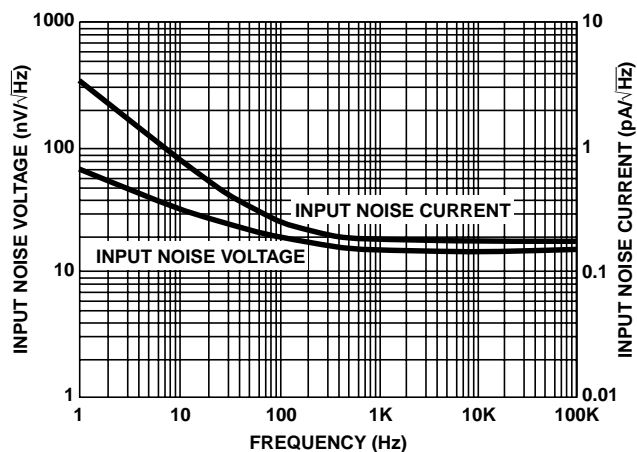

FIGURE 5. INPUT NOISE CHARACTERISTICS

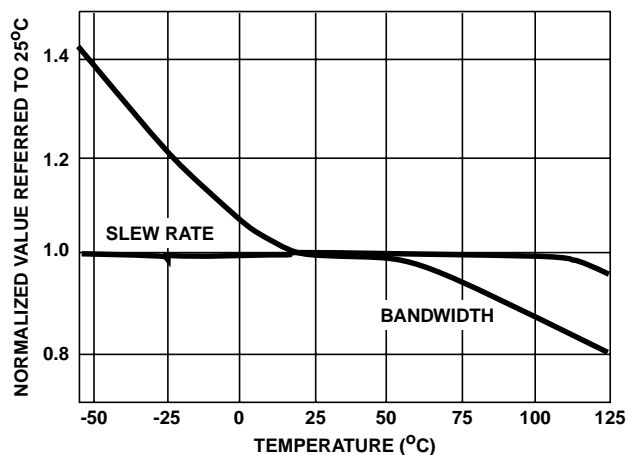

FIGURE 6. NORMALIZED AC PARAMETERS vs TEMPERATURE

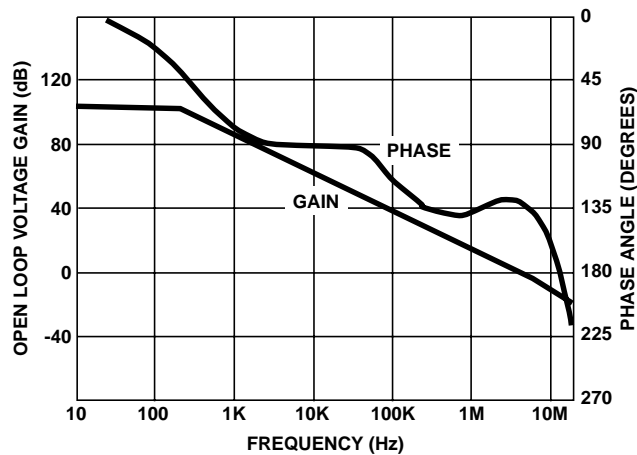

FIGURE 7. OPEN LOOP FREQUENCY RESPONSE

HA-2640, HA-2645

Typical Performance Curves $V_S = \pm 40V$, $T_A = 25^\circ C$, Unless Otherwise Specified (Continued)

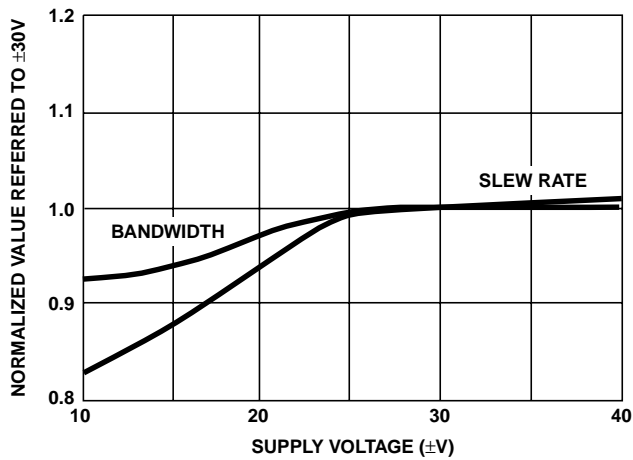

FIGURE 8. NORMALIZED AC PARAMETERS vs SUPPLY VOLTAGE AT 25°C

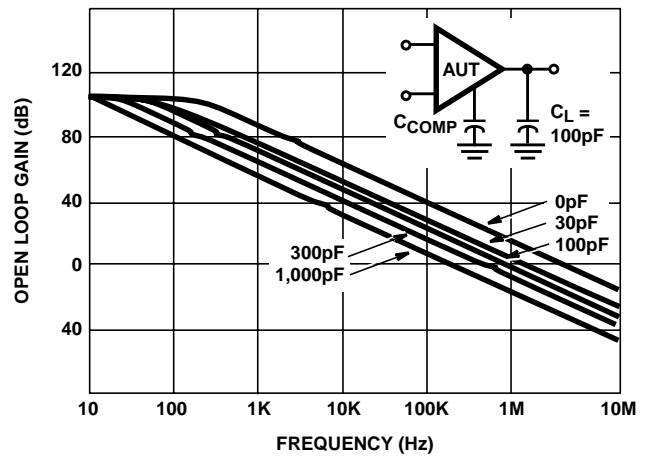

FIGURE 9. OPEN LOOP FREQUENCY RESPONSE FOR VARIOUS VALUES OF CAPACITORS FROM COMPENSATION PIN TO GROUND

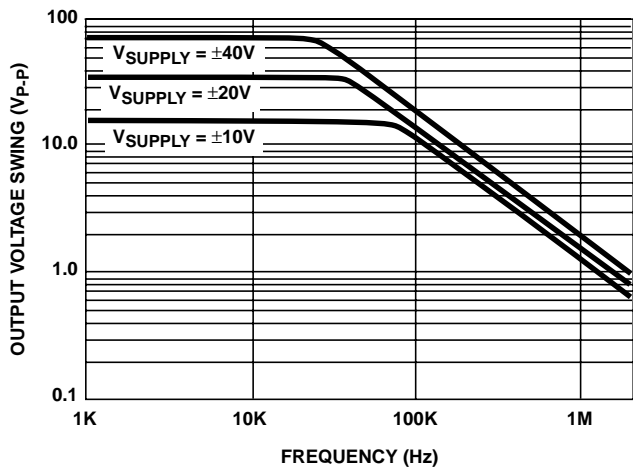

FIGURE 10. OUTPUT VOLTAGE SWING vs FREQUENCY

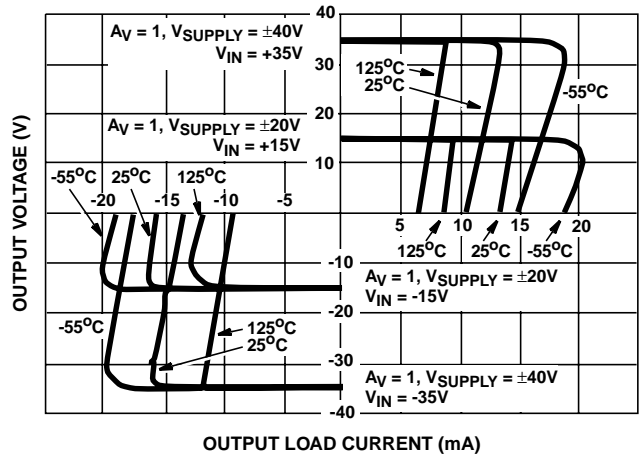

FIGURE 11. OUTPUT CURRENT CHARACTERISTIC

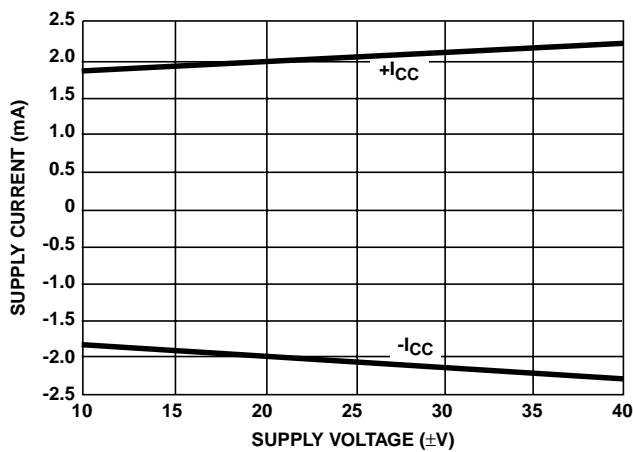

FIGURE 12. SUPPLY CURRENT vs SUPPLY VOLTAGE

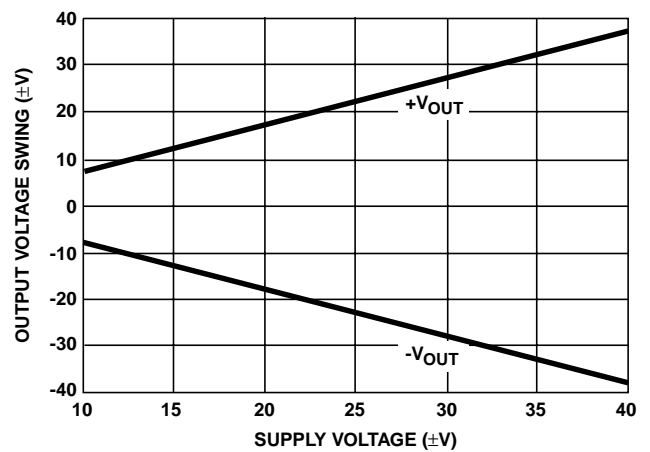

FIGURE 13. OUTPUT VOLTAGE SWING vs SUPPLY VOLTAGE

HA-2640, HA-2645

Die Characteristics

DIE DIMENSIONS:

93 mils x 68 mils x 19 mils
2360 μ m x 1720 μ m x 483 μ m

METALLIZATION:

Type: Al, 1% Cu
Thickness: 16k \AA \pm 2k \AA

PASSIVATION:

Type: Nitride (Si₃N₄) over Silox (SiO₂, 5% Phos.)
Silox Thickness: 12k \AA \pm 2k \AA
Nitride Thickness: 3.5k \AA \pm 1.5k \AA

SUBSTRATE POTENTIAL (Powered Up):

Unbiased

TRANSISTOR COUNT:

76

PROCESS:

HV200 Bipolar Dielectric Isolation

Metallization Mask Layout

HA-2640, HA-2645

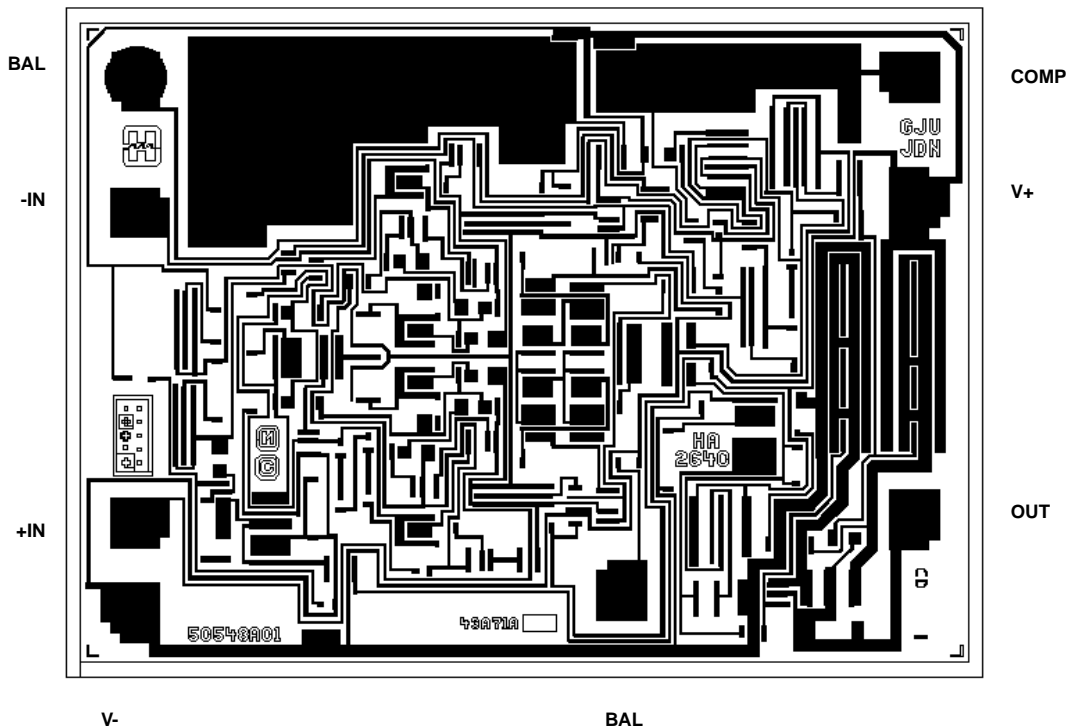

All Intersil semiconductor products are manufactured, assembled and tested under **ISO9000** quality systems certification.

Intersil semiconductor products are sold by description only. Intersil Corporation reserves the right to make changes in circuit design and/or specifications at any time without notice. Accordingly, the reader is cautioned to verify that data sheets are current before placing orders. Information furnished by Intersil is believed to be accurate and reliable. However, no responsibility is assumed by Intersil or its subsidiaries for its use; nor for any infringements of patents or other rights of third parties which may result from its use. No license is granted by implication or otherwise under any patent or patent rights of Intersil or its subsidiaries.

For information regarding Intersil Corporation and its products, see web site www.intersil.com

Sales Office Headquarters

NORTH AMERICA

Intersil Corporation
P. O. Box 883, Mail Stop 53-204
Melbourne, FL 32902
TEL: (321) 724-7000
FAX: (321) 724-7240

EUROPE

Intersil SA
Mercure Center
100, Rue de la Fusee
1130 Brussels, Belgium
TEL: (32) 2.724.2111
FAX: (32) 2.724.22.05

ASIA

Intersil (Taiwan) Ltd.
7F-6, No. 101 Fu Hsing North Road
Taipei, Taiwan
Republic of China
TEL: (886) 2 2716 9310
FAX: (886) 2 2715 3029