

## 2.5MHz, Precision Operational Amplifier

The Intersil HA-5135 is a precision operational amplifier manufactured using a combination of key technological advancements to provide outstanding input characteristics.

A Super Beta input stage is combined with laser trimming, dielectric isolation and matching techniques to produce 75 $\mu$ V (Maximum) input offset voltage and 0.4 $\mu$ V/ $^{\circ}$ C input offset voltage average drift. Other features enhanced by this process include 9nV/ $\sqrt{\text{Hz}}$  (Typ) Input Noise Voltage, 1nA Input Bias Current and 140dB Open Loop Gain.

These features coupled with 120dB CMRR and PSRR make the HA-5135 an ideal device for precision DC instrumentation amplifiers. Excellent input characteristics in conjunction with 2.5MHz bandwidth and 0.8V/ $\mu$ s slew rate, make this amplifier extremely useful for precision integrator and biomedical amplifier designs. This amplifier is also well suited for precision data acquisition and for accurate threshold detector applications.

HA-5135 offers added features over the industry standard OP-07 in regards to bandwidth and slew rate specifications. For the military grade product, refer to the HA-5135/883 data sheet.

### Pinout

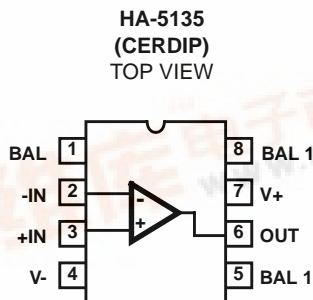

NOTE: Both BAL 1 pins are connected together internally.

### Features

- Low Offset Voltage . . . . . 75 $\mu$ V (Max)
- Low Offset Voltage Drift . . . . . 0.4 $\mu$ V/ $^{\circ}$ C
- Low Noise . . . . . 9nV/ $\sqrt{\text{Hz}}$
- Open Loop Gain . . . . . 140dB
- Unity Gain Bandwidth . . . . . 2.5MHz
- All Bipolar Construction

### Applications

- High Gain Instrumentation
- Precision Data Acquisition
- Precision Integrators
- Biomedical Amplifiers
- Precision Threshold Detectors

### Ordering Information

PART NUMBER	TEMP. RANGE ( $^{\circ}$ C)	PACKAGE	PKG. NO.
HA7-5135-5	0 to 75	8 Ld CERDIP	F8.3A



## HA-5135

### Absolute Maximum Ratings

Voltage Between V+ and V- Terminals	40V
Differential Input Voltage	7V
Output Short Circuit Duration	Indefinite

### Thermal Information

Thermal Resistance (Typical, Note 2)	$\theta_{JA}$ ( $^{\circ}\text{C}/\text{W}$ )	$\theta_{JC}$ ( $^{\circ}\text{C}/\text{W}$ )
CERDIP Package	135	50
Maximum Junction Temperature (Note 1)	175 $^{\circ}\text{C}$	
Maximum Storage Temperature Range	-65 $^{\circ}\text{C}$ to 150 $^{\circ}\text{C}$	
Maximum Lead Temperature (Soldering 10s)	300 $^{\circ}\text{C}$	

### Operating Conditions

Temperature Ranges	
HA-5135-5	0 $^{\circ}\text{C}$ to 75 $^{\circ}\text{C}$

**CAUTION:** Stresses above those listed in "Absolute Maximum Ratings" may cause permanent damage to the device. This is a stress only rating and operation of the device at these or any other conditions above those indicated in the operational sections of this specification is not implied.

#### NOTES:

- Maximum power dissipation, including output load, must be designed to maintain the maximum junction temperature below 175 $^{\circ}\text{C}$ .
- $\theta_{JA}$  is measured with the component mounted on an evaluation PC board in free air.

### Electrical Specifications $V_{\text{SUPPLY}} = \pm 15\text{V}$

PARAMETER	TEST CONDITIONS	TEMP. ( $^{\circ}\text{C}$ )	HA-5135-5			UNITS
			MIN	TYP	MAX	
<b>INPUT CHARACTERISTICS</b>						
Offset Voltage		25	-	10	75	$\mu\text{V}$
		Full	-	50	130	$\mu\text{V}$
Average Offset Voltage Drift		Full	-	0.4	1.3	$\mu\text{V}/^{\circ}\text{C}$
Bias Current		25	-	$\pm 1$	$\pm 4$	nA
		Full	-	-	$\pm 6$	nA
Bias Current Average Drift		Full	-	0.02	0.04	nA/ $^{\circ}\text{C}$
Offset Current		25	-	-	4	nA
		Full	-	-	5.5	nA
Offset Current Average Drift		Full	-	0.02	0.04	nA/ $^{\circ}\text{C}$
Common Mode Range		Full	$\pm 12$	-	-	V
Differential Input Resistance		25	20	30	-	M $\Omega$
Input Noise Voltage (Note 3)	0.1Hz to 10Hz	25	-	-	0.6	$\mu\text{V}_{\text{p-p}}$
Input Noise Voltage Density (Note 3)	f = 10Hz	25	-	13.0	18.0	nV/ $\sqrt{\text{Hz}}$
	f = 100Hz		-	10.0	13.0	nV/ $\sqrt{\text{Hz}}$
	f = 1000Hz		-	9.0	11.0	nV/ $\sqrt{\text{Hz}}$
Input Noise Current (Note 3)	0.1Hz to 10Hz	25	-	15	30	pA $_{\text{p-p}}$
Input Noise Current Density (Note 3)	f = 10Hz	25	-	0.4	0.8	pA/ $\sqrt{\text{Hz}}$
	f = 100Hz		-	0.17	0.23	pA/ $\sqrt{\text{Hz}}$
	f = 1000Hz		-	0.14	0.17	pA/ $\sqrt{\text{Hz}}$
<b>TRANSFER CHARACTERISTICS</b>						
Large Signal Voltage Gain	$V_{\text{OUT}} = \pm 10\text{V}$ , $R_L = 2\text{k}\Omega$	25	120	140	-	dB
		Full	120	-	-	dB
Common Mode Rejection Ratio	$V_{\text{CM}} = \pm 10\text{V}$	Full	106	120	-	dB
Closed Loop Bandwidth	$A_{\text{VCL}} = +1$	25	0.6	2.5	-	MHz
<b>OUTPUT CHARACTERISTICS</b>						
Output Voltage Swing	$R_L = 600\Omega$	25	$\pm 10$	$\pm 12$	-	V
		Full	$\pm 10$	-	-	V

# HA-5135

## Electrical Specifications $V_{SUPPLY} = \pm 15V$ (Continued)

PARAMETER	TEST CONDITIONS	TEMP. (°C)	HA-5135-5			UNITS
			MIN	TYP	MAX	
Full Power Bandwidth (Note 4)	$R_L = 2k\Omega$	25	8	10	-	kHz
Output Current	$V_{OUT} = 10V$	25	$\pm 15$	$\pm 20$	-	mA
Output Resistance	Note 5	25	-	45	-	$\Omega$
<b>TRANSIENT RESPONSE</b> (Note 6)						
Rise Time		25	-	340	-	ns
Slew Rate		25	0.5	0.8	-	V/ $\mu s$
Settling Time (Note 7)		25	-	11	-	$\mu s$
<b>POWER SUPPLY CHARACTERISTICS</b>						
Supply Current		Full	-	1.0	1.7	mA
Power Supply Rejection Ratio	$V_S = \pm 5V$ to $\pm 20V$	Full	94	130	-	dB

**NOTES:**

- Not tested. 90% of units meet or exceed these specifications.
- Full power bandwidth guaranteed based on slew rate measurement using:  $FPBW = \frac{\text{Slew Rate}}{2\pi V_{PEAK}}$ .
- Output resistance measured under open loop conditions ( $f = 100\text{Hz}$ ).
- Refer to test circuits section of the data sheet.
- Settling time is measured to 0.1% of final value for a 10V output step and  $A_V = -1$ .

## Test Circuits and Waveforms

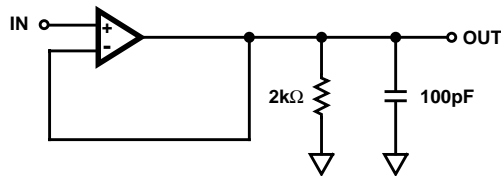
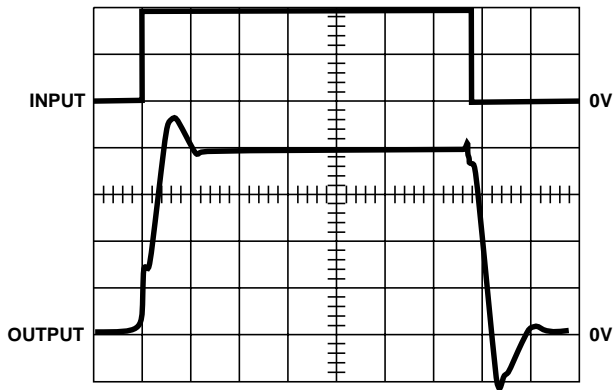
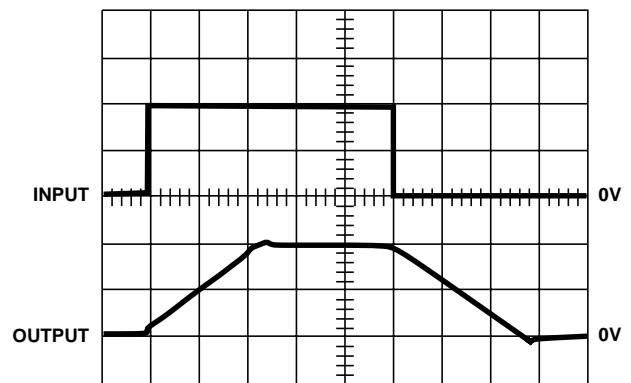

FIGURE 1. SLEW RATE AND TRANSIENT RESPONSE TEST CIRCUIT



Vertical Scale: Input = 50mV/Div. Output = 100mV/Div.  
Horizontal Scale: 1 $\mu s$ /Div.

SMALL SIGNAL RESPONSE



Vertical Scale: 5V/Div.  
Horizontal Scale: 5 $\mu s$ /Div.

LARGE SIGNAL RESPONSE

# HA-5135

## Test Circuits and Waveforms (Continued)

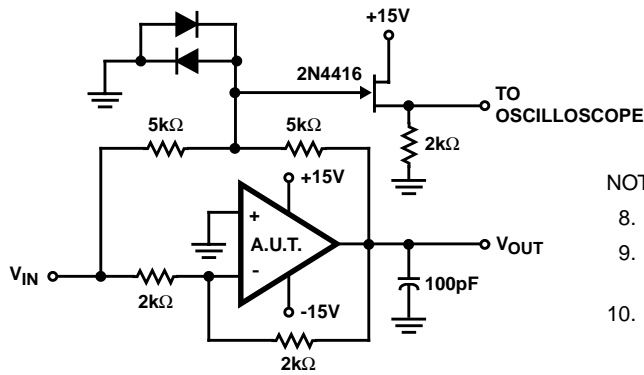

### NOTES:

8.  $A_V = -1$ .
9. Feedback and summing resistors should be 0.1% matched.
10. Clipping diodes are optional. HP5082-2810 recommended.

FIGURE 2. SETTLING TIME CIRCUIT

## Schematic Diagram

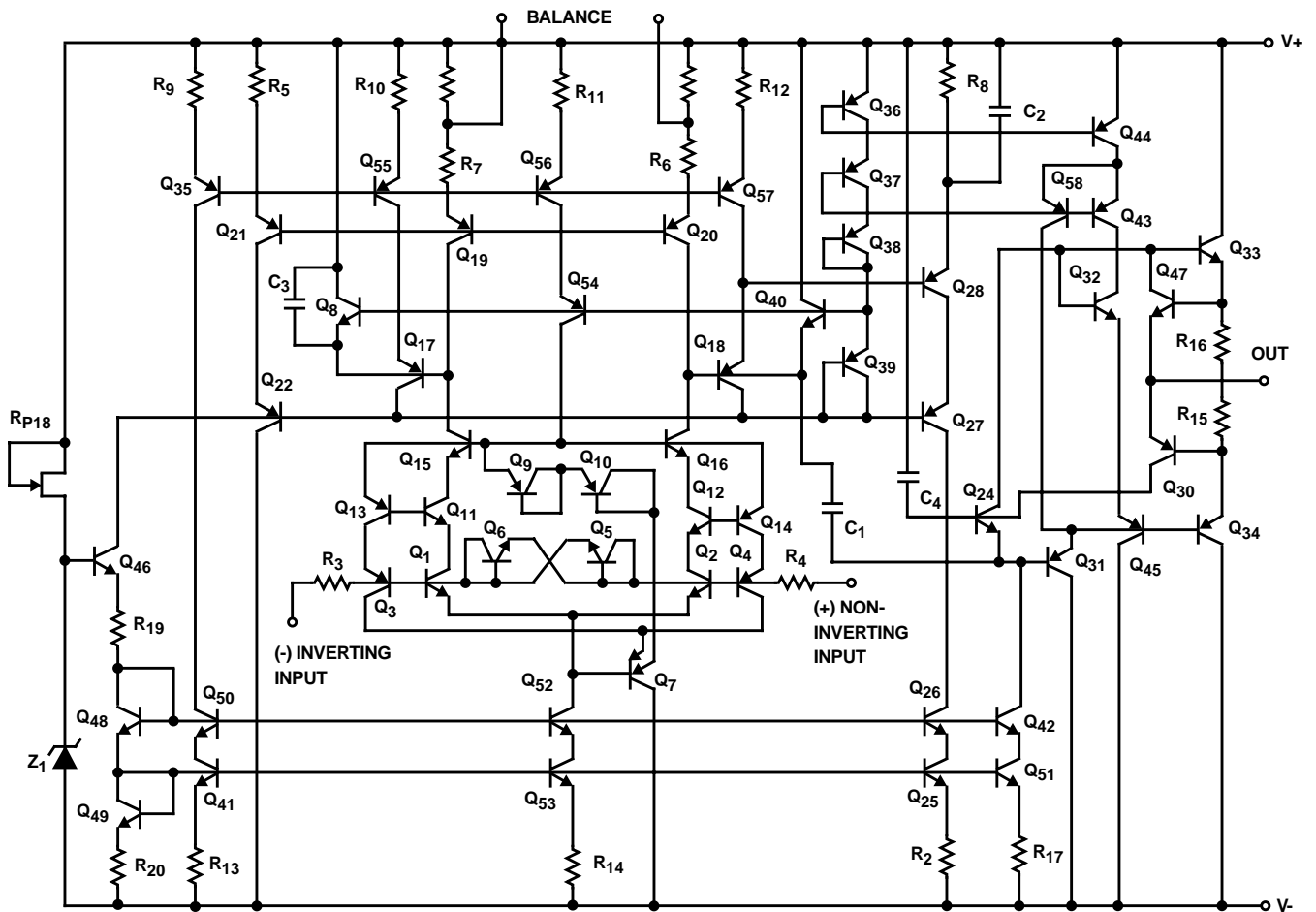

**Application Information**

**Power Supply Decoupling**

Although not absolutely necessary, it is recommended that all power supply lines be decoupled with 0.01 $\mu$ F ceramic capacitors to ground. Decoupling capacitors should be located as near to the amplifier terminals as possible.

**Considerations For Prototyping:**

The following list of recommendations are suggested for prototyping.

1. Resolving low level signals requires minimizing leakage currents caused by external circuitry. Use of quality insulating materials, thorough cleaning of insulating surfaces and implementation of moisture barriers when required is suggested.
2. Error voltages generated by thermocouples formed between dissimilar metals in the presence of temperature gradients should be minimized. Isolation of low level circuitry from heat generating components is recommended.
3. Shielded cable input leads, guard rings and shield drivers are recommended for the most critical applications.

**Large Capacitive Loads**

When driving large capacitive loads (>500pF), a small value resistor ( $\approx$ 50 $\Omega$ ) should be connected in series with the output and inside the feedback loop.

**Offset Voltage Adjustment (See Figure 3)**

A 20k $\Omega$  balance potentiometer is recommended if offset nulling is required. However, other potentiometer values such as 10k $\Omega$ , 50k $\Omega$  and 100k $\Omega$  may be used. The minimum adjustment range for given values is  $\pm$ 2mV.  $V_{OS}$  TC of the amplifier is optimized at minimal  $V_{OS}$ . Tested Offset Adjustment is  $|V_{OS} + 1mV|$  minimum referred to output.

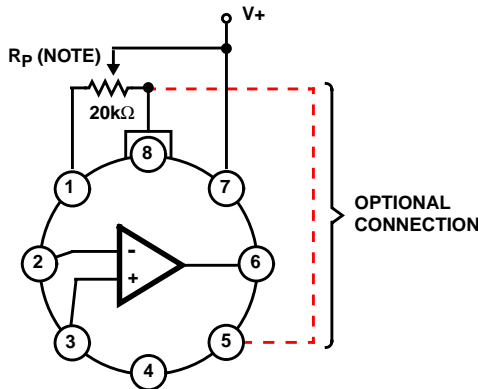

FIGURE 3. OFFSET NULLING CONNECTIONS

**Saturation Recovery**

Input and output saturation recovery time is negligible in most applications. However, care should be exercised to avoid exceeding the absolute maximum ratings of the device.

**Differential Input Voltages**

Inputs are shunted with back-to-back diodes for overvoltage protection. In applications where differential input voltages in excess of 1V are applied between the inputs, the use of limiting resistors at the inputs is recommended.

**Typical Applications**

The excellent input and gain characteristics of HA-5135 are well suited for precision integrator applications. Accurate integration over seven decades of frequency using HA-5135, virtually nullifies the need for more expensive chopper-type amplifiers.

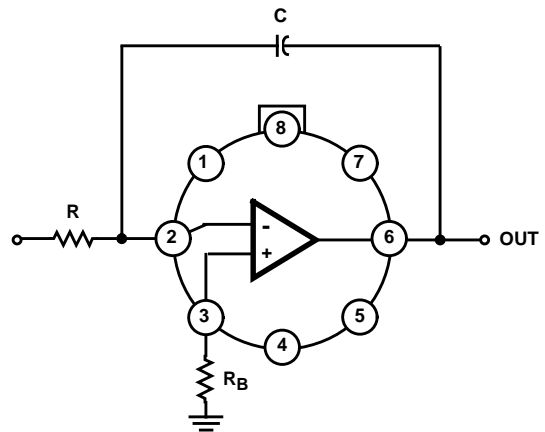

FIGURE 4. PRECISION INTEGRATOR

Low  $V_{OS}$  coupled with high open loop Gain, high CMRR and high PSRR make HA-5135 ideally suited for precision detector applications, such as the zero crossing detector shown in Figure 5.

# HA-5135

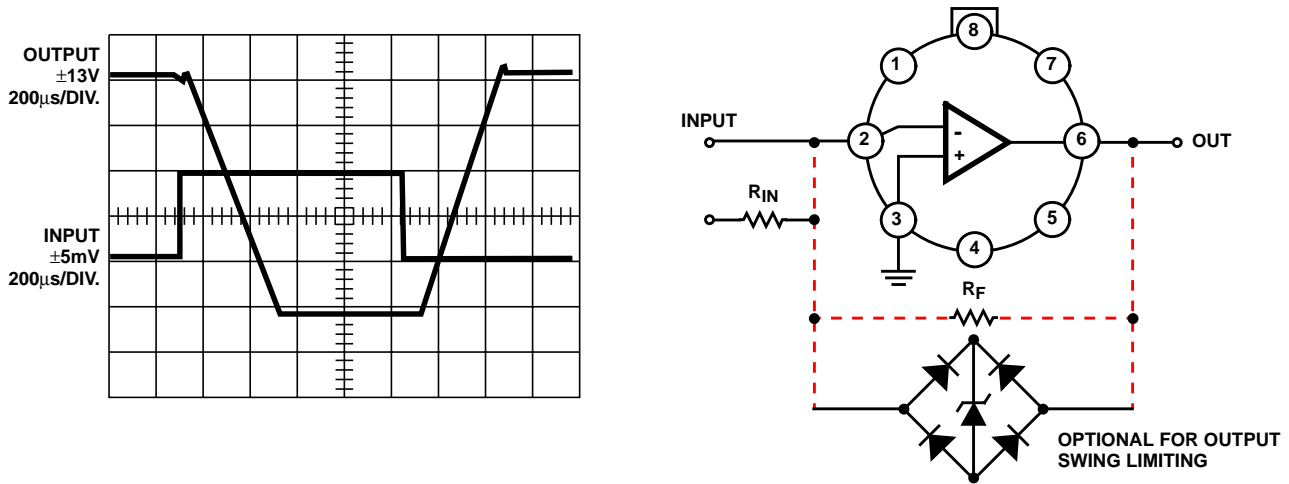

FIGURE 5. ZERO CROSSING DETECTOR

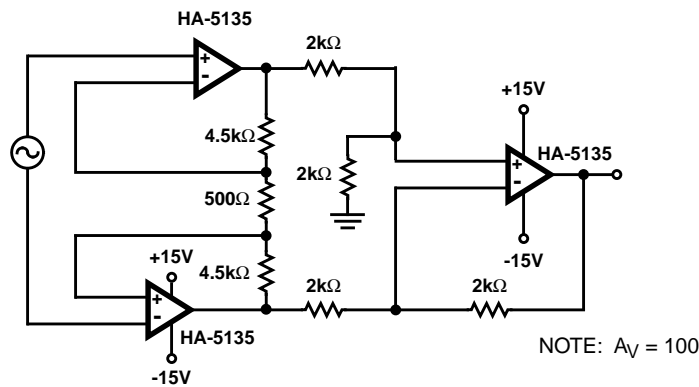

FIGURE 6. PRECISION INSTRUMENTATION AMPLIFIER

## Typical Performance Curves

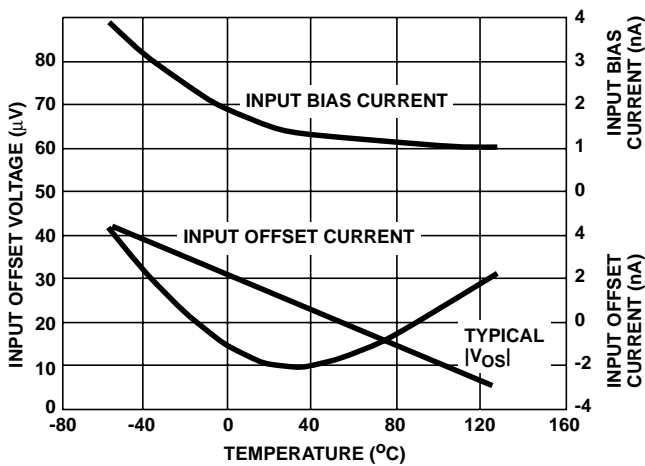

FIGURE 7. INPUT OFFSET VOLTAGE, INPUT BIAS AND OFFSET CURRENT vs TEMPERATURE

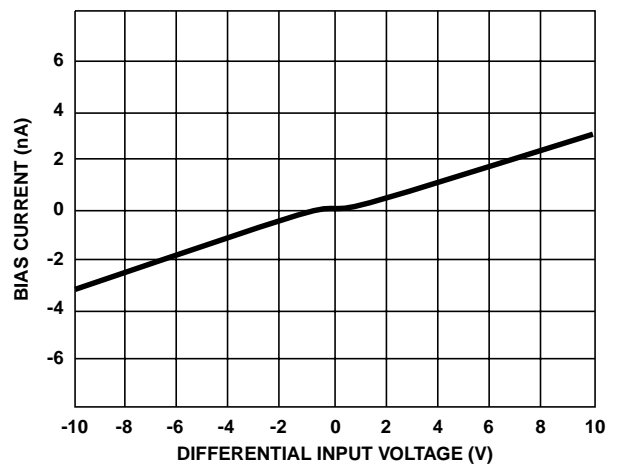

FIGURE 8. INPUT BIAS CURRENT vs DIFFERENTIAL INPUT VOLTAGE

Typical Performance Curves (Continued)

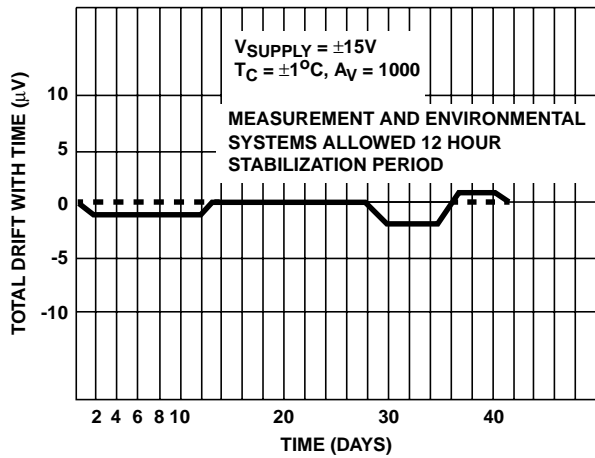

FIGURE 9. HA-5135 OFFSET VOLTAGE STABILITY vs TIME

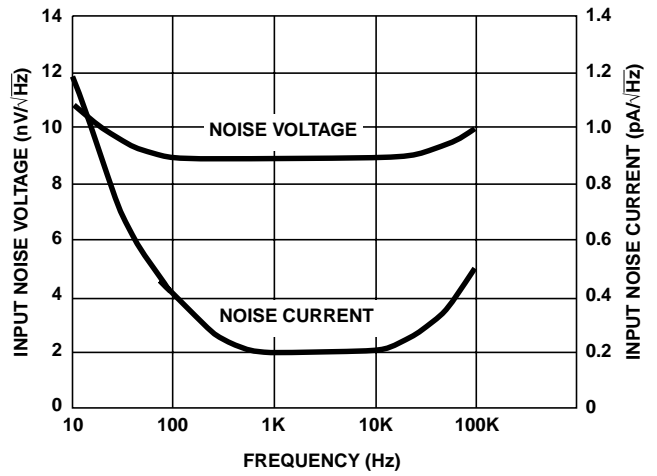

FIGURE 10. INPUT NOISE vs FREQUENCY

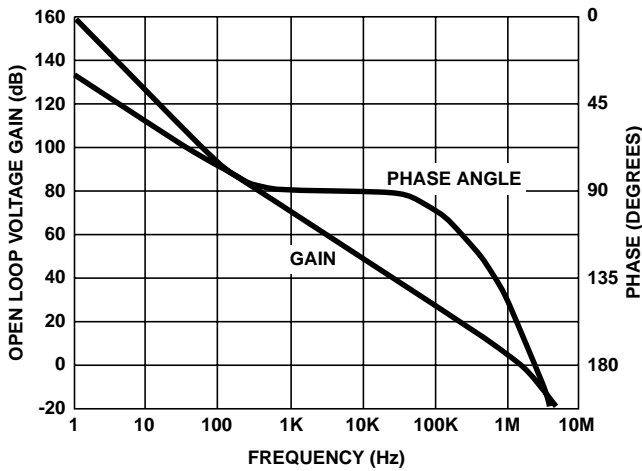

FIGURE 11. OPEN LOOP FREQUENCY RESPONSE

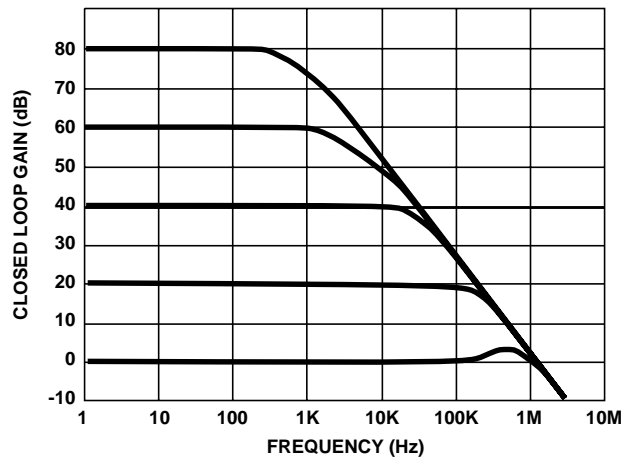

FIGURE 12. CLOSED LOOP FREQUENCY RESPONSE

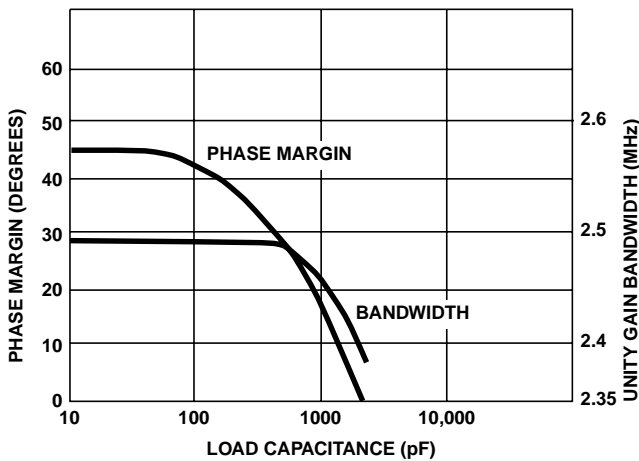

FIGURE 13. SMALL SIGNAL BANDWIDTH AND PHASE MARGIN vs LOAD CAPACITANCE

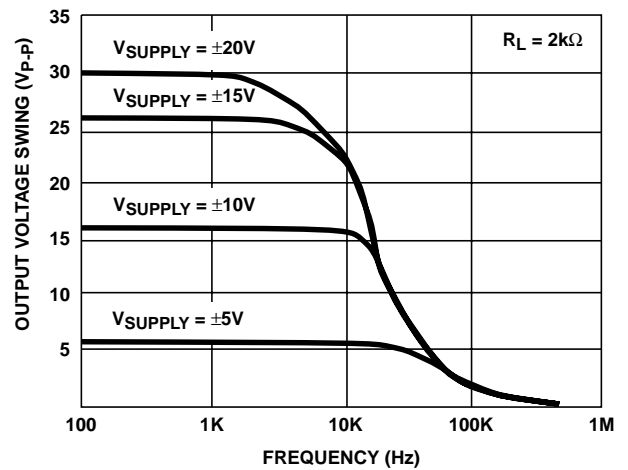

FIGURE 14. OUTPUT VOLTAGE SWING vs FREQUENCY

Typical Performance Curves (Continued)

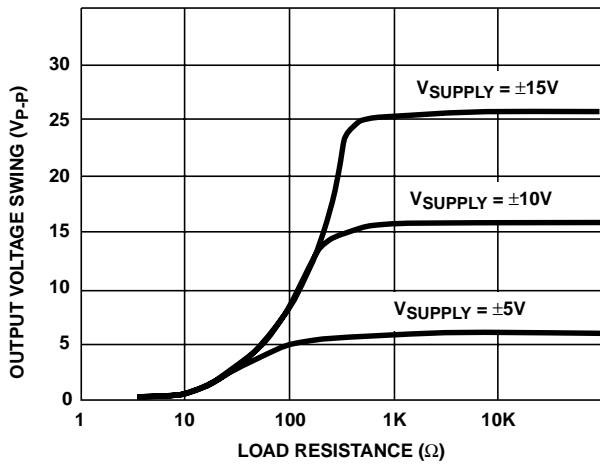

FIGURE 15. MAXIMUM OUTPUT VOLTAGE SWING vs LOAD RESISTANCE

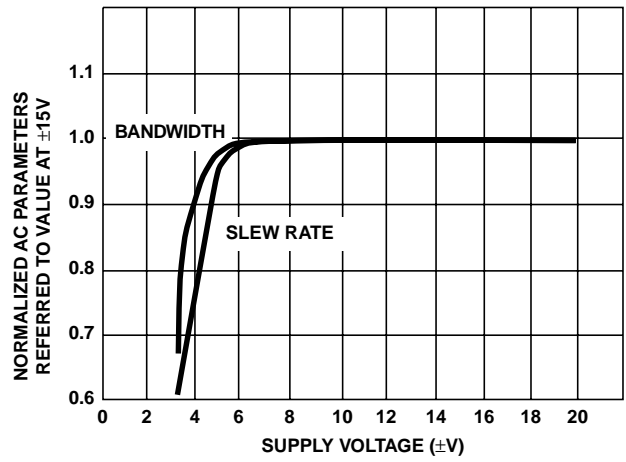

FIGURE 16. NORMALIZED AC PARAMETERS vs SUPPLY VOLTAGE

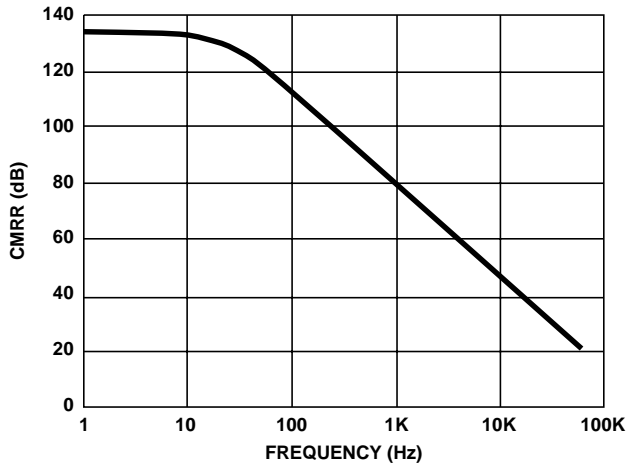

FIGURE 17. CMRR vs FREQUENCY

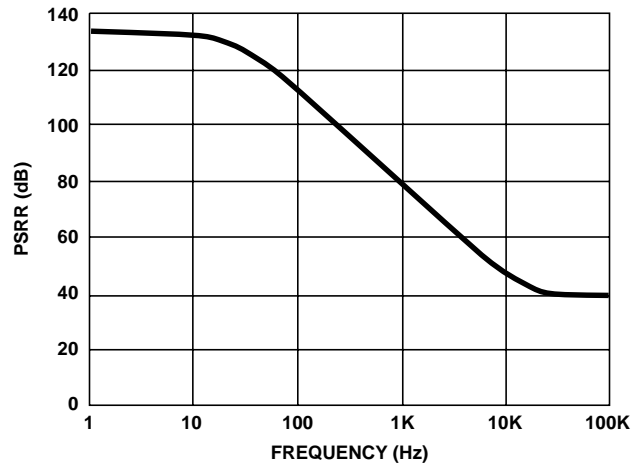

FIGURE 18. PSRR vs FREQUENCY

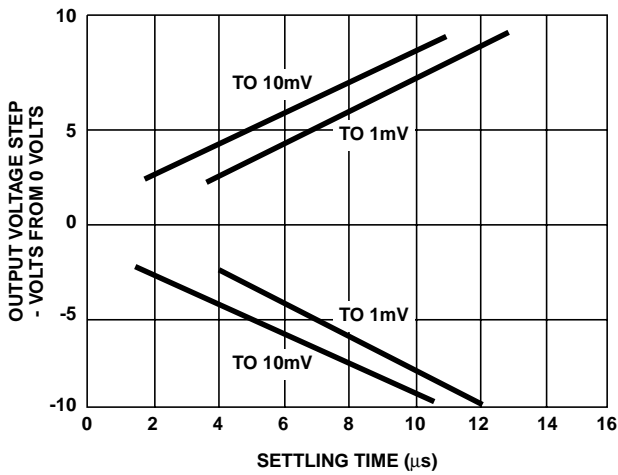

FIGURE 19. SETTLING TIME FOR VARIOUS OUTPUT STEP VOLTAGES

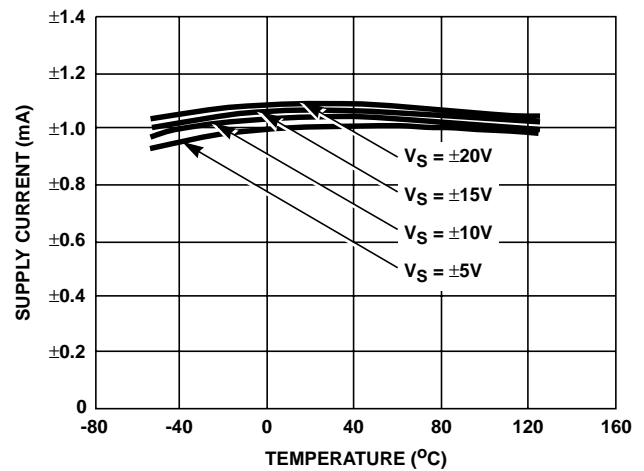

FIGURE 20. POWER SUPPLY CURRENT vs TEMPERATURE

## HA-5135

### Die Characteristics

#### DIE DIMENSIONS:

72 mils x 103 mils x 19 mils  
(1840 $\mu$ m x 2620 $\mu$ m x 483 $\mu$ m)

#### METALLIZATION:

Type: Al, 1% Cu  
Thickness: 16k $\text{\AA}$   $\pm$  2k $\text{\AA}$

#### SUBSTRATE POTENTIAL (POWERED UP):

V-

#### PASSIVATION:

Type: Nitride ( $\text{Si}_3\text{N}_4$ ) over Silox ( $\text{SiO}_2$ , 5% Phos.)  
Silox Thickness: 12k $\text{\AA}$   $\pm$  2k $\text{\AA}$   
Nitride Thickness: 3.5k $\text{\AA}$   $\pm$  1.5k $\text{\AA}$

#### TRANSISTOR COUNT:

71

#### PROCESS:

Bipolar Dielectric Isolation

### Metallization Mask Layout

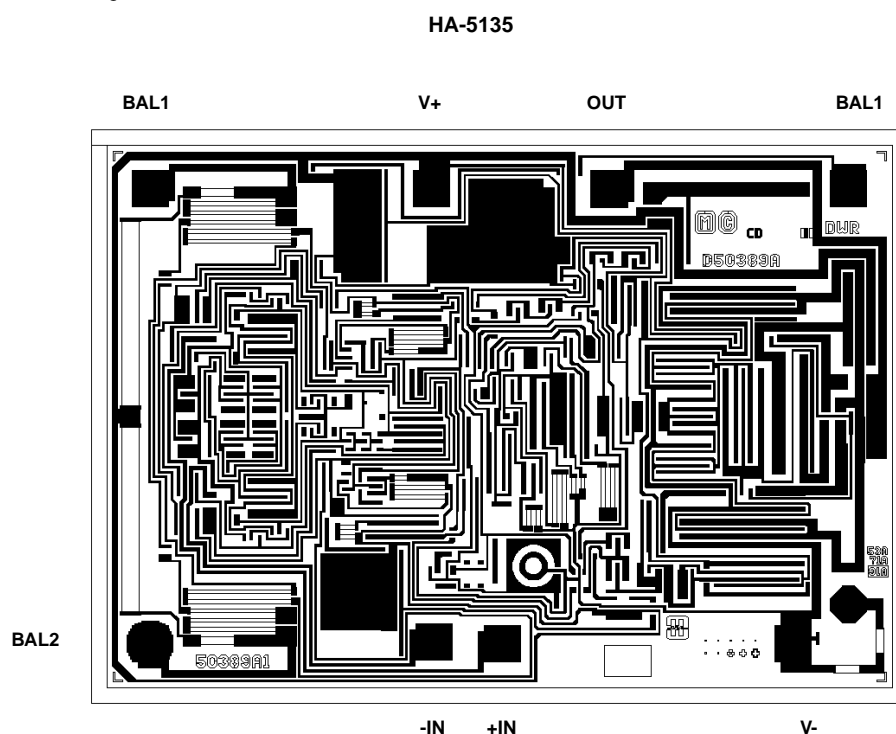

All Intersil semiconductor products are manufactured, assembled and tested under **ISO9000** quality systems certification.

*Intersil semiconductor products are sold by description only. Intersil Corporation reserves the right to make changes in circuit design and/or specifications at any time without notice. Accordingly, the reader is cautioned to verify that data sheets are current before placing orders. Information furnished by Intersil is believed to be accurate and reliable. However, no responsibility is assumed by Intersil or its subsidiaries for its use; nor for any infringements of patents or other rights of third parties which may result from its use. No license is granted by implication or otherwise under any patent or patent rights of Intersil or its subsidiaries.*

For information regarding Intersil Corporation and its products, see web site [www.intersil.com](http://www.intersil.com)

### Sales Office Headquarters

#### NORTH AMERICA

Intersil Corporation  
P. O. Box 883, Mail Stop 53-204  
Melbourne, FL 32902  
TEL: (321) 724-7000  
FAX: (321) 724-7240

#### EUROPE

Intersil SA  
Mercure Center  
100, Rue de la Fusee  
1130 Brussels, Belgium  
TEL: (32) 2.724.2111  
FAX: (32) 2.724.22.05

#### ASIA

Intersil (Taiwan) Ltd.  
7F-6, No. 101 Fu Hsing North Road  
Taipei, Taiwan  
Republic of China  
TEL: (886) 2 2716 9310  
FAX: (886) 2 2715 3029