

HA12002

Protector of Speakers and Power Amplifiers

The Hitachi monolithic IC HA12002 is designed for protecting power amplifiers and speakers in various amplifiers and receivers. The HA12002 is encapsulated in 8-pin single-in-line package.

FEATURES

- Built-in-relay driver
- Single power source
- Wide operating supply voltage range: (25 to 60V)
- Plus and minus voltage detections using one pin (both pins 3 and 4 possess the same functions and detect plus and minus voltages)
- AC voltage detector (pin-5)
- Circuit protection by plus voltage detection is provided by connecting D1 diode externally (pin-6). (See Note)
- Relay-on lag time adjustable by external applications.
- Short relay-off time (25ms typ under the standard external applications)

RECOMMENDED APPLICATIONS

- For speakers protection, use pin-3 (or pin-4) to detect setoff of quiescent output DC voltage and to turn the relay off.
- For protection of power amplifiers, use pin-3 (or pin-4) with an external thermo-sensitive device to detect the temperature increase and to turn the relay off.
- Power amplifiers can be protected by detecting overload and turning the relay off with pin-6.



Note: Once relay is turned off, the relay off state continues until the power is switched off and then on again.

- In case of overload detection by constant-current drive or by constant-voltage drive using an external diode D1, the latch mechanism keeps the relay being on until the power is switched off.
- For prevention of pop noise at power off, use pin-5. AC voltage disappearance is immediately detected when the amp's switch has been off. This minimized the relay-off time and thus can prevent pop noise generated by mute-off time lag.

INTERNAL SCHEMATIC DIAGRAM AND RECOMMENDED EXTERNAL APPLICATIONS

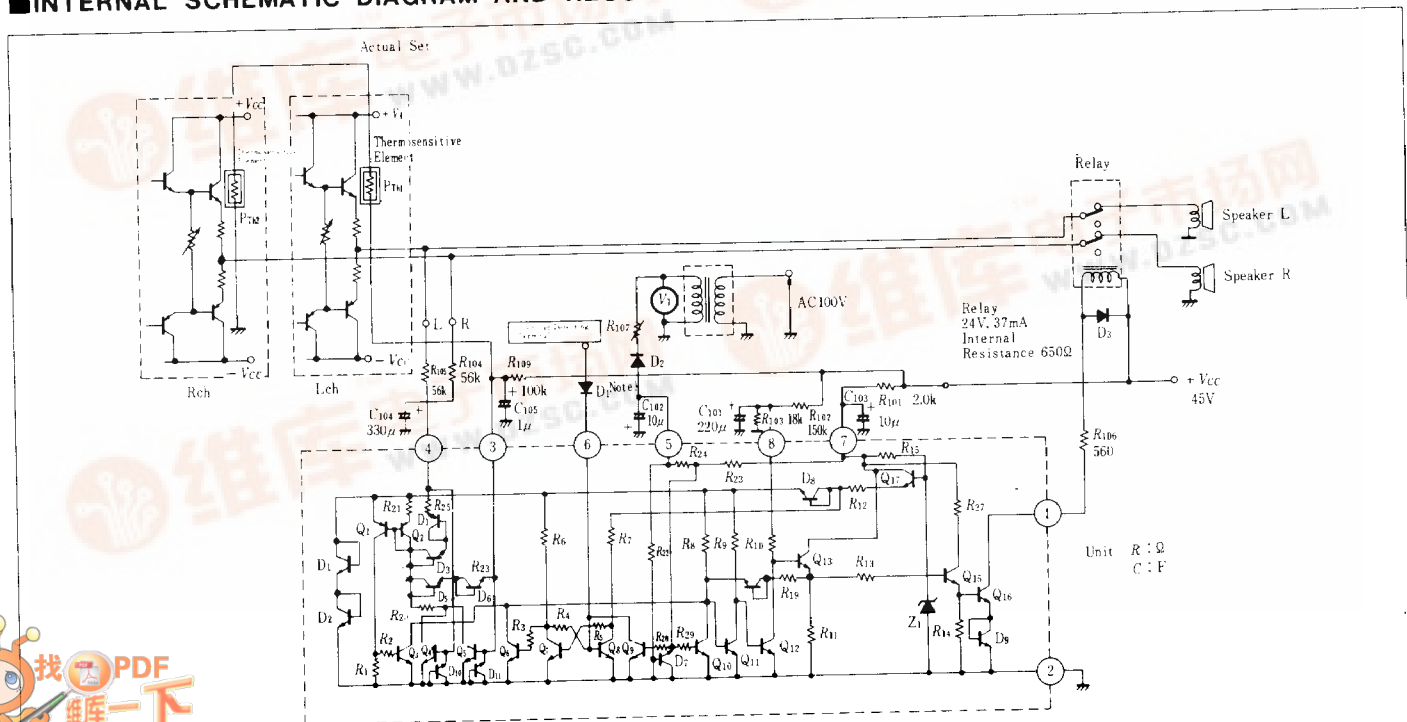

Note: When detecting an overload under a constant current drive, the latch functions without diode D1, however, when under a constant voltage drive, the latch functions with D1.



■ BLOCK DIAGRAM

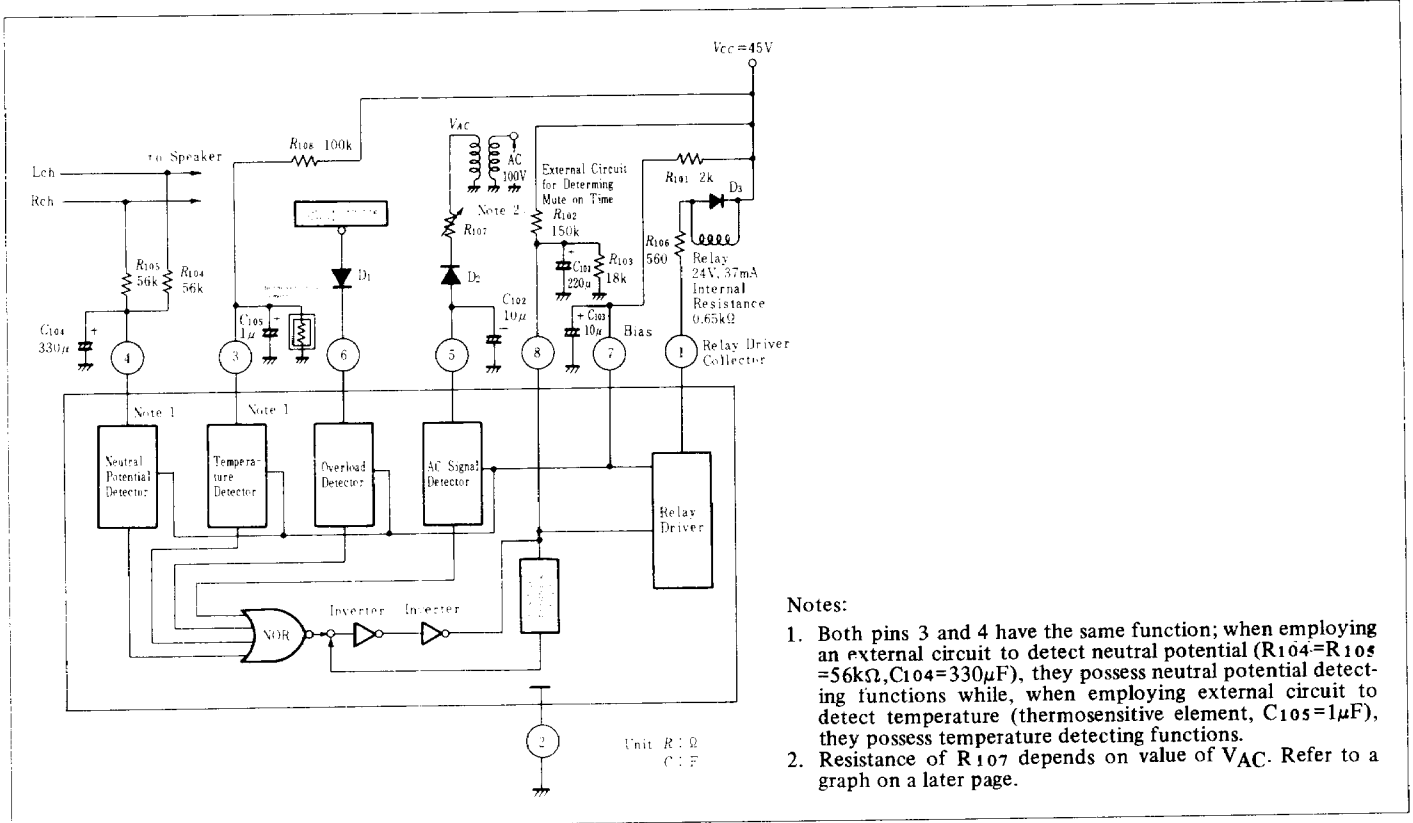

■ ABSOLUTE MAXIMUM RATINGS ($T_a=25^\circ C$)

Item	Symbol	Rating	Unit
Power Dissipation	P_T	400*	mW
Operating Temperature	T_{opr}	-20 to +70	$^\circ C$
Storage Temperature	T_{stg}	-55 to +125	$^\circ C$
Supply Voltage (pin 1)	$V_{CC(max)}$	60	V
Max. Current for Pin 1	$I_{\textcircled{1}(max)}$	80	mA
Max. Current for Pin 3	$I_{\textcircled{3}(max)}$	$\pm 3^{**}$	mA
Max. Current for Pin 4	$I_{\textcircled{4}(max)}$	$\pm 3^{**}$	mA
Max. Voltage for Pin 5	$V_{\textcircled{5}(max)}$	-10	V
Max. Current for Pin 6	$I_{\textcircled{6}(max)}$	3	mA
Max. Voltage for Pin 7	$V_{\textcircled{7}(max)}$	8^{***}	V
Max. Current for Pin 7	$I_{\textcircled{7}(max)}$	25^{***}	mA
Max. Voltage for Pin 8	$V_{\textcircled{8}(max)}$	less than voltage of pin 7	V
Max. Current for Pin 8	$I_{\textcircled{8}(max)}$	50	mA(peak)

Notes: * : Value at $T_a=70^\circ C$

** : Positive current denotes input current at pins 3 and 4, negative current denotes output current.

*** : $V_{\textcircled{7}(max)}=8V$ is derived when driven by a constant voltage source, without any resistance. When applying current to $V_{\textcircled{7}}$ through a resistance V_{CC} , the max. value of the input current to pin 7 should be used instead of the above values.

■ ELECTRICAL CHARACTERISTICS (V_{CC} = 45V)

Item	Symbol	Test Conditions	min.	typ.	max.	Unit
Threshold voltage at pin 3, positive side	+V _{th(3)}	Apply positive voltage to pin 3 through an external resistance (56kΩ). Measure pin 3 voltage while pin 1 voltage changes from low (1.0V) to high (45V) during the above process.	0.89	1.20	1.61	V
Threshold voltage at pin 3, negative side	-V _{th(3)}	Apply negative voltage to pin 3 through an external resistance (56kΩ). Measure pin 3 voltage while pin 1 voltage changes from low (1.0V) to high (45V) during the above process.	-1.86	-1.20	-0.84	V
Threshold voltage at pin 4, positive side	+V _{th(4)}	Apply positive voltage to pin 4 through an external resistance (56kΩ). Measure pin 4 voltage while pin 1 voltage changes from low (1.0V) to high (45V) during the above process.	0.89	1.20	1.61	V
Threshold voltage at pin 4, negative side	-V _{th(4)}	Apply negative voltage to pin 4 through an external resistance (56kΩ). Measure pin 4 voltage while pin 1 voltage changes from low (1.0V) to high (45V) during the above process.	-1.86	-1.20	-0.84	V
Threshold voltage at pin 6	V _{th(6)}	Apply voltage to pin 6 through D ₁ . Measure pin 6 voltage while pin 1 voltage change from low (1.0V) to high (45V) during the above process.	0.90	1.15	1.40	V
Threshold AC voltage at pin 5	V _{AC(5)}	Apply AC voltage to pin 5 through D ₂ . Measure AC voltage while pin 1 voltage change from low (1.0V) to high (45V) during the above process.	-	2.5	-	V _{rms}
Threshold voltage at pin 5	V _{th(5)}	Apply voltage to pin 5 directly. Measure voltage of pin 5 while pin 1 voltage changes from low (1.0V) to high (45V) during the above process.	-1.8	-1.2	0	V
Current drain at pin 7	I ₍₇₎	Measure pin 7 input current when turning relay on.	16.5	18.5	20.5	mA

■ TEST CIRCUIT

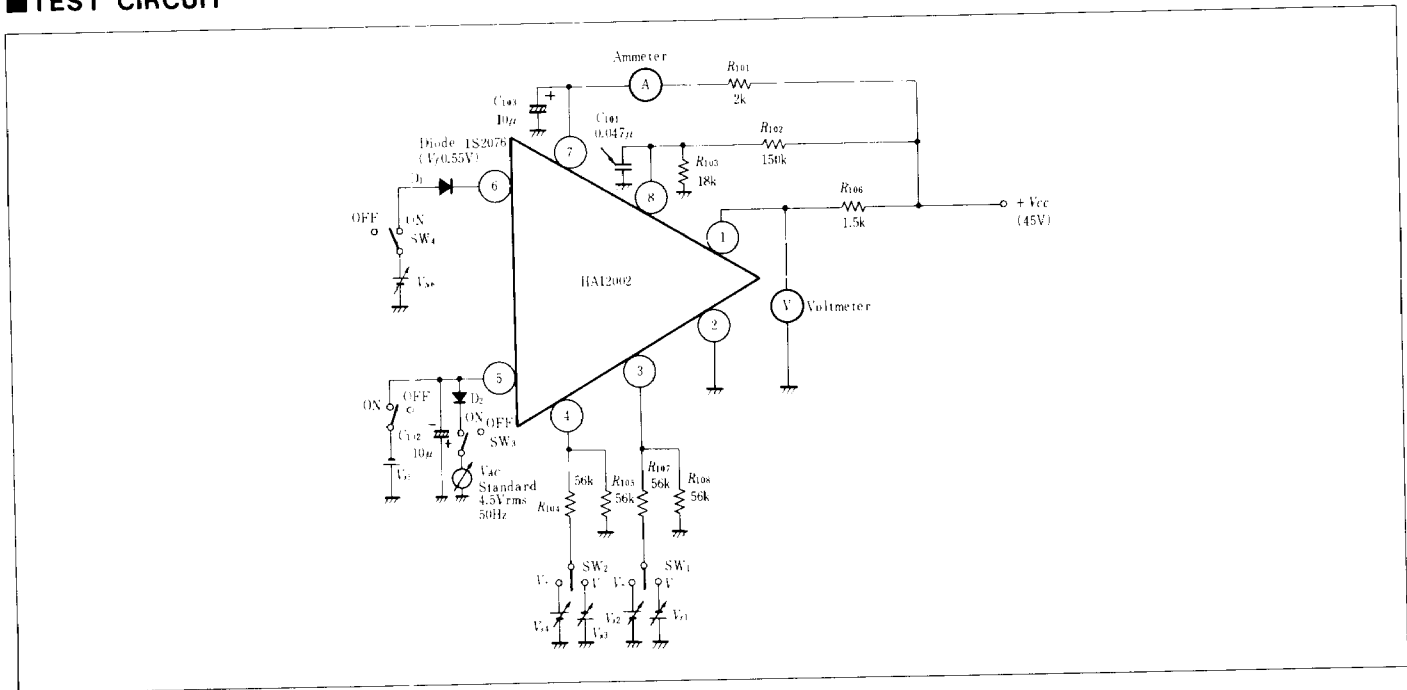

■ CHARACTERISTICS

This unit has been developed specifically for protection of speakers and power amplifiers. Following characteristics are delivered by giving careful consideration to the designing.

- Detection of Quiescent Output DC Voltage Setoff — pin-3 or 4

Both plus and minus sides DC voltage setoff can be detected with one power supply. This detection protects

- Determination of Plus and Minus Threshold Voltages — pin-3 or 4

Threshold voltage for turning the relay on or off can be defined by external applications as follows.

Plus side threshold voltage +V_{th} is defined as

$$+V_{th} = \left(2 + \frac{R_{104}}{R_{110}} \right) V_{a+} \quad \dots \text{eq. 1}$$

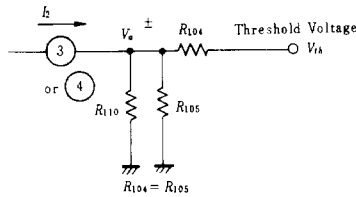

where \$V_{a+}\$ is 0.57V typ, the threshold voltage with a plus voltage applied directly to pin-3 or 4.

Minus side threshold voltage \$-V_{th}\$ is defined as

$$-V_{th} = - \left\{ V_{a-} \left(2 + \frac{R_{104}}{R_{110}} \right) + I_2 \cdot R_{104} \right\} \dots \dots \text{eq. 2}$$

where \$V_{a-}\$ is -0.28V typ, the threshold voltage with a minus voltage applied directly to pin-3 or 4 and where \$I_2\$ is 12.5µA typ, the pull-out current.

Plus and minus unbalanced thresholds can be corrected by adjusting \$R_{104}\$ and \$R_{110}\$ so as to satisfy

$$\left\{ V_{a-} \left(2 + \frac{R_{104}}{R_{110}} \right) + I_2 \cdot R_{104} \right\} = \left(2 + \frac{R_{104}}{R_{110}} \right) V_{a+} \dots \dots \text{eq. 3}$$

The plus-side threshold voltage has approximately 40mV hysteresis and the minus-side threshold voltage has approximately 300mV hysteresis.

((Example Applications))

\$R_{104}\$, \$R_{105}\$ and \$R_{110}\$ external resistor values can be defined to meet \$\pm V_{th}=1.8V\$,

(a) From eq. 1 and \$\pm V_{th}=1.8V\$,

$$1.8 = \left(2 + \frac{R_{104}}{R_{110}} \right) \times 0.57 \quad (V)$$

Therefore \$R_{104}/R_{110}\$ is defined as

$$\frac{R_{104}}{R_{110}} = 1.158$$

(b) From eq. 2 and \$-V_{th}=-1.8V\$,

$$-1.8 = -0.28 \left(2 + \frac{R_{104}}{R_{110}} \right) - 12.5 (\mu A) \times R_{104} (k\Omega) \quad (V)$$

$$R_{104} = \frac{1.8 - 0.884}{12.5} = 73.3 \quad (k\Omega)$$

$$R_{110} = 63.3 \quad (k\Omega)$$

Therefore, for \$V_{th}=1.8V\$,

$$R_{104} = R_{105} = 75 \quad (k\Omega)$$

$$R_{110} = 62 \quad (k\Omega)$$

Minimum values of \$R_{104}\$ and \$R_{105}\$ can be defined by the maximum ratings of pin-3 and 4 (\$\pm 3mA\$).

$$\frac{\pm V_{cc}}{R_{104} (105)} < \pm 3 \quad (mA)$$

Employing the recommended application values, \$R_{104} = R_{105} = 56k\Omega\$, \$R_{110} = \infty\$, threshold voltage can be defined as follows.

$$(a) \quad +V_{th} = \left(2 + \frac{56k\Omega}{\infty} \right) 0.57 = 1.14 \quad (V)$$

$$(b) \quad -V_{th} = -0.28 \left(2 + \frac{56k\Omega}{\infty} \right) - 12.5\mu A \cdot 56k\Omega = -1.26(V)$$

• Temperature Increase Detection – pin-3 or 4

Pin-3 or 4 with an external thermo-sensitive device protects power amplifiers by detecting temperature increase and turning the relay off. Please see the recommended external applications.

• Relay-off by AC Voltage Disappearance Detection

The time from power amp's switch off to the relay off depends on the charging time determined by pin-5 voltage level, an external capacitor \$C_{102}\$ and internal resistors \$R_{22}\$, \$R_{23}\$, \$R_{24}\$. When pin-5 voltage is -3.5V with the typical applications, relay-off time is defined as 25ms typ.

• Overload Detection – Pin-6

When using pin-6 as overload-detecting constant-current drive pin, the threshold current is 110µA typ. Thus over 110µA current causes the relay to go off. In this case, latch function operates without an external diode \$D_1\$. (When using constant-voltage drive, \$D_1\$ is needed for latching.)

• Relay-on Time Lag – pin-8

To prevent pop noise at power on, time constant circuit at pin-8 lags relay-on after power amp's switch is turned on.

The relay-on time lag is defined as

$$t = \frac{R_{102} \cdot R_{103} \cdot C_{101}}{R_{102} + R_{103}} \cdot \ln \left\{ \frac{1}{1 - \frac{V_{th(8)} \cdot (R_{103} + R_{102})}{V_{cc} \cdot R_{103}}} \right\}$$

where \$V_{th(8)}\$ is 2.65V typ, pin-8 threshold voltage.

• Wide Operating Supply Voltage Range – pin-7

\$V_{cc}=25\$ to \$60V\$ can be obtained by an optimum \$R_{101}\$ value.

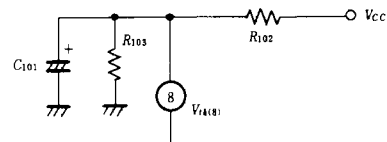

■ PC-BOARD LAYOUT PATTERN

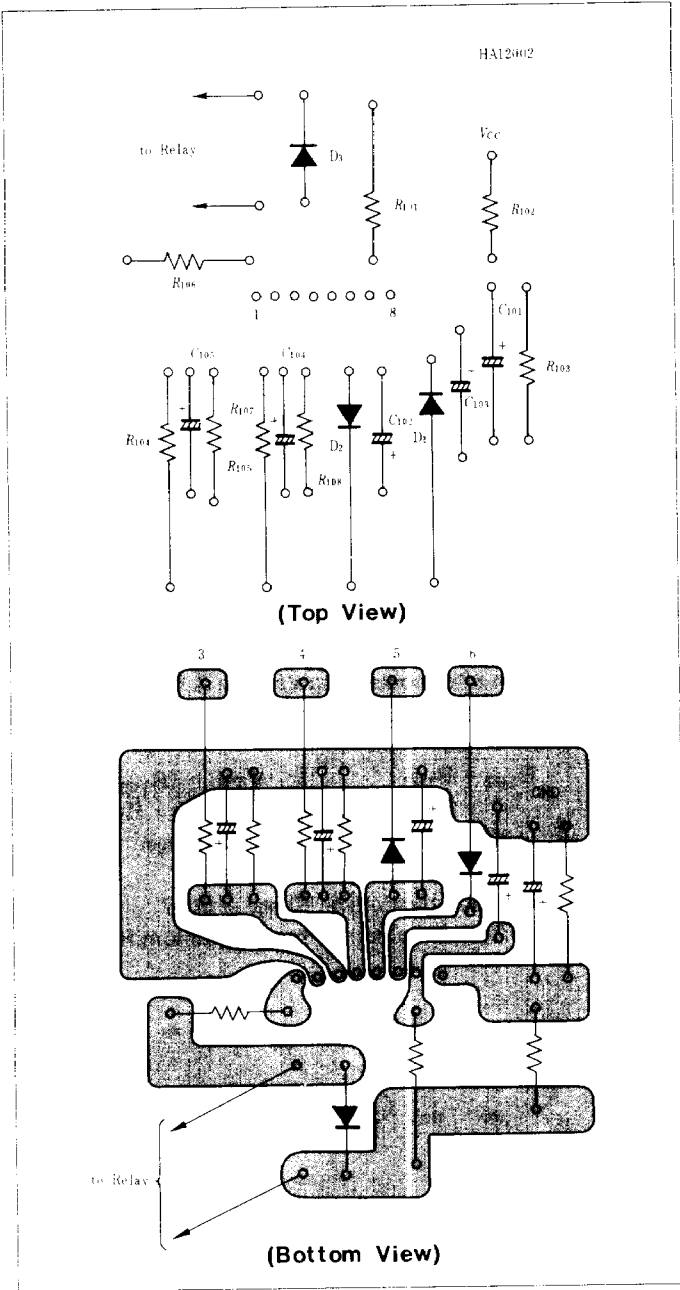

《SELECTING AN OPTIMAL R_{107} VALUE》
 R_{107} VS. COMMERCIAL AC VOLTAGE

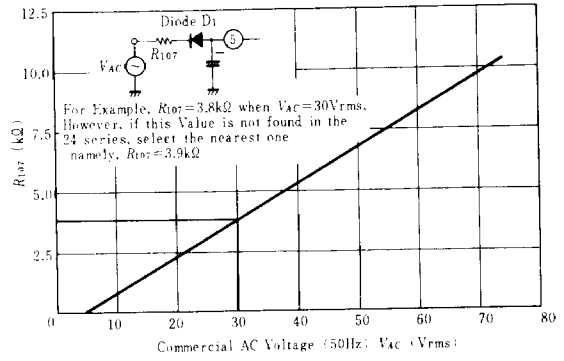

《SELECTING AN OPTIMAL R_{101} VALUE》
 R_{101} VS. SUPPLY VOLTAGE

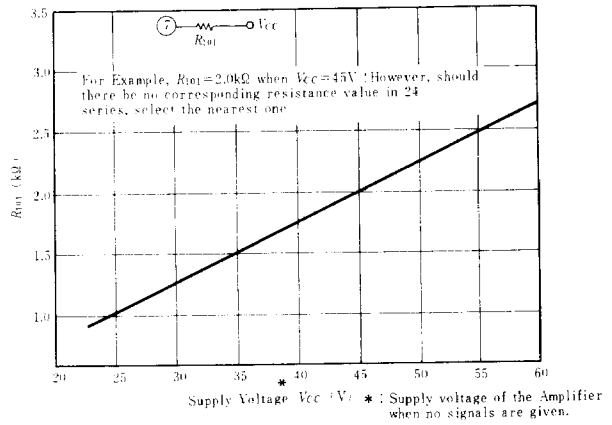

$\pm V_{th(3), (4)}$, V_{AC} (on), MUTE ON TIME VS. AMBIENT TEMPERATURE

