

---

# HA12211NT

Audio Signal Processor for Cassette Deck (Deck 1 Chip)

# HITACHI

ADE-207-223A (Z)

2nd. Edition  
June 1997

---

## Description

HA12211NT is silicon monolithic bipolar IC providing REC equalizer system, PB equalizer system and each electronic control switch in one chip.

## Functions

- PB equalizer × 2 channel
- REC equalizer × 2 channel
- Each electronic control switch to change equalizer characteristics
- REC mute
- REC head return switch

## Features

- REC equalizer is very small number of external parts.(4 types of frequency characteristics built-in)
- PB equalizer built-in. (A/B input changing system, 4 types of frequency characteristics)
- Independent PB sensitivity for A deck, B deck.
- Normal-speed/high-speed, normal tape/chrome tape switching built-in.
- Controllable from direct micro-computer output.
- Available to reduce substrate-area because of high integration and small external parts.

# HA12211NT

**Pin Description, Equivalent Circuit** ( $V_{CC} = 10.5V$ ,  $V_{ref} = 5.25V$ ,  $T_a = 25^\circ C$ , No signal, The value in the table show typical value.)

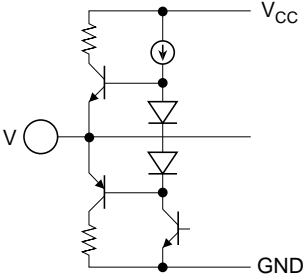
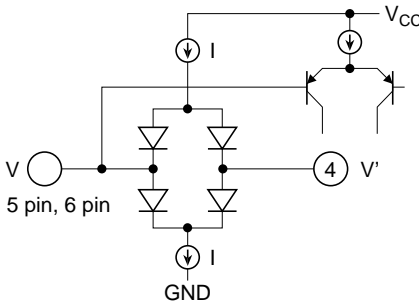
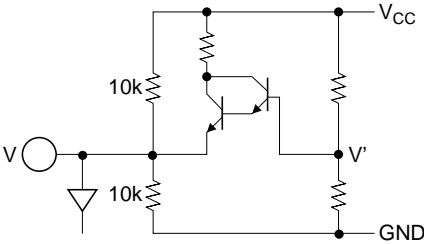
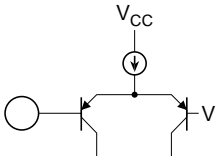
Pin No.	Pin Name	Note	Equivalent Circuit	Pin Description
1	$V_{CC}$	$V = V_{CC}$		$V_{CC}$ Pin
2	RECOUT (L)	$V = V_{ref}$		REC-EQ output
3	RECOUT (R)			
4	REC-RETURN	$V = V_{ref}$ $V' = V_{ref}$		REC Return
5	PB-IN B (L)			PB B Deck input
6	PB-IN B (R)			
7	VREF	$V = V_{ref}$ $V' = V_{CC} / 2$		Reference
8	PB-IN A(L)	$V = V_{ref}$		PB A Deck input
9	PB-IN A(R)			

**Pin Description, Equivalent Circuit** ( $V_{CC} = 10.5V$ ,  $V_{ref} = 5.25V$ ,  $T_a = 25^\circ C$ , No signal, The value in the table show typical value.) (cont)

Pin No.	Pin Name	Note	Equivalent Circuit	Pin Description
10	PB-NF (L)	$V = V_{ref}$		PB EQ Feed back
11	PB-NF (R)			
12	PB-EQ (L)	$V = V_{ref}$		NAB Output
13	PB-EQ (R)			
14	PB-Cal A(L)	$V = V_{ref}$		Feed back input for gain adjustment
15	PB-Cal A(R)			
16	PB-Cal B(R)			
17	PB-Cal B(L)			
26	AUX (R)	$V = V_{ref}$		REC-EQ input
27	AUX (L)			
28	TAPE (R)			
29	TAPE (L)			

# HA12211NT

**Pin Description, Equivalent Circuit** ( $V_{CC} = 10.5V$ ,  $V_{ref} = 5.25V$ ,  $T_a = 25^\circ C$ , No signal, The value in the table show typical value.) (cont)

Pin No.	Pin Name	Note	Equivalent Circuit	Pin Description
18	PBOUT (R)	$V = V_{ref}$		PB output
19	PBOUT (L)			
20	A/B	$I = 20\mu A$		Mode control input
21	HSP			
22	Acr			
23	Bcr			
24	REC-SEL	$I = 20\mu A$ $V = 2.5V$		Mode control input
25	IREF	$V = 1.2V$		Equalizer reference current input
30	GND			GND Pin

Block Diagram

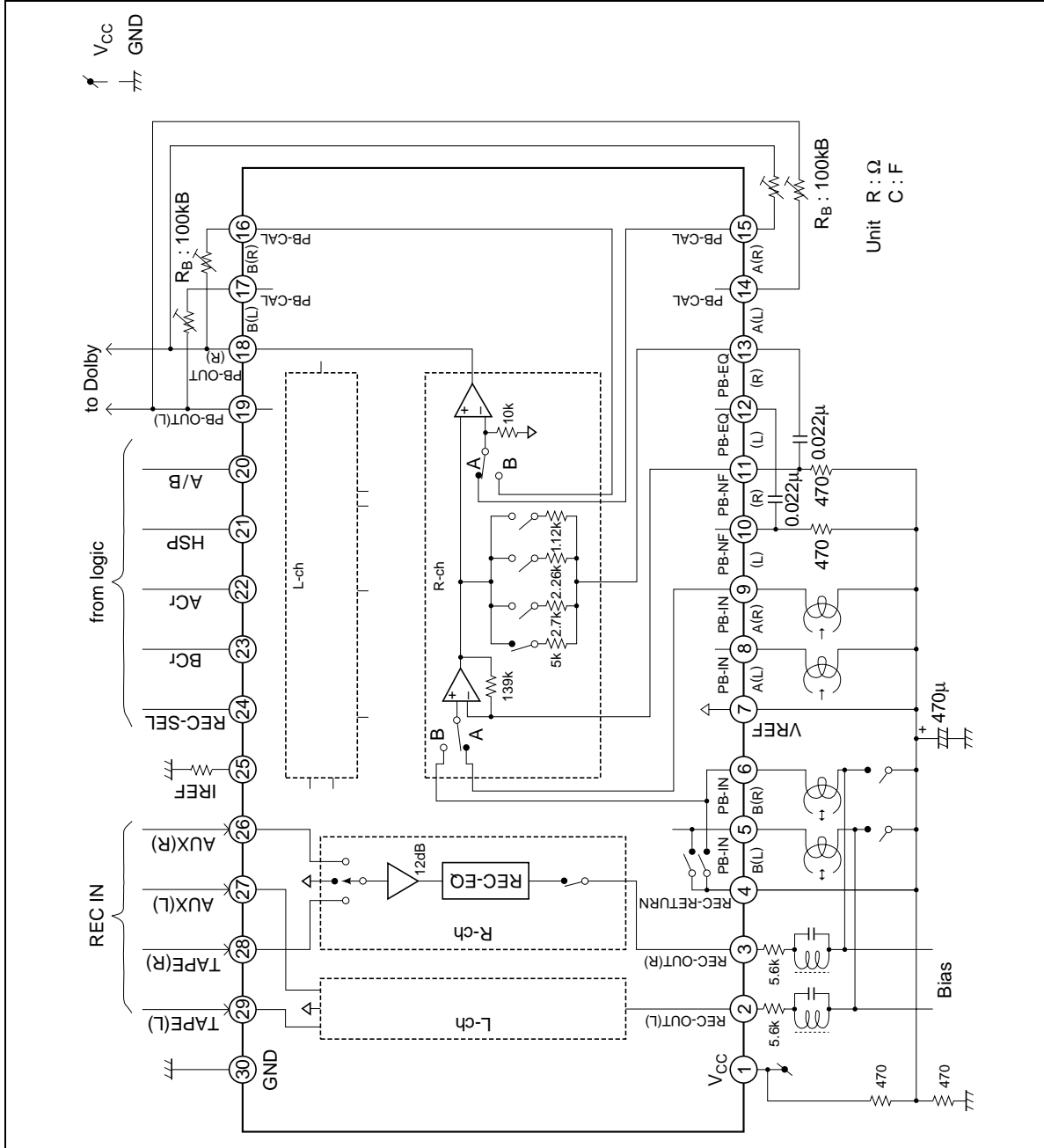

# HA12211NT

## Parallel Data Format

Pin No.	Pin Name	L	M	H
22	A CrO2	*1, *3	—	*1
23	B CrO2	*1, *2, *3	—	*1, *2
21	HSP	Normal speed *3	—	Hi speed
20	A/B	Ain active *1, *3	—	Bin active *1
		Return SW ON *3	—	Return SW OFF
		REC OUT active *3	—	REC OUT Hiz
24	REC IN SEL	TAPE	MUTE *3	AUX

Note: 1. PB-EQ LOGIC

		HSP			
		L		H	
		A/B			
A CrO2	B CrO2	L	H	L	H
L	L	120μ	120μ	60μ	60μ
L	H	120μ	70μ	60μ	35μ
H	L	70μ	120μ	35μ	60μ
H	H	70μ	70μ	35μ	35μ

2. REC-EQ LOGIC

		HSP	
B CrO2		L	H
L		Normal speed TAPE I	High speed TAPE I
H		Normal speed TAPE II	High speed TAPE II

3. Unforced pin state

**Functional Description**

**Power Supply Range**

This IC is designed to operate on single supply, shown by table 1.

**Table 1    Sply Voltage**

Item	Power Supply Range
Single Supply	9.5V to 15.0V

**Reference Voltage**

So little is the current drivability of AC reference (Vref) that the Vref voltage may be altered by A/B switching of PB-EQ.

Provided it causes you anxiety, please use the constant 1/2 V<sub>cc</sub> voltage circuit, for example, figure 1.

In addition, this IC has a capacitor charger for Vref pin.

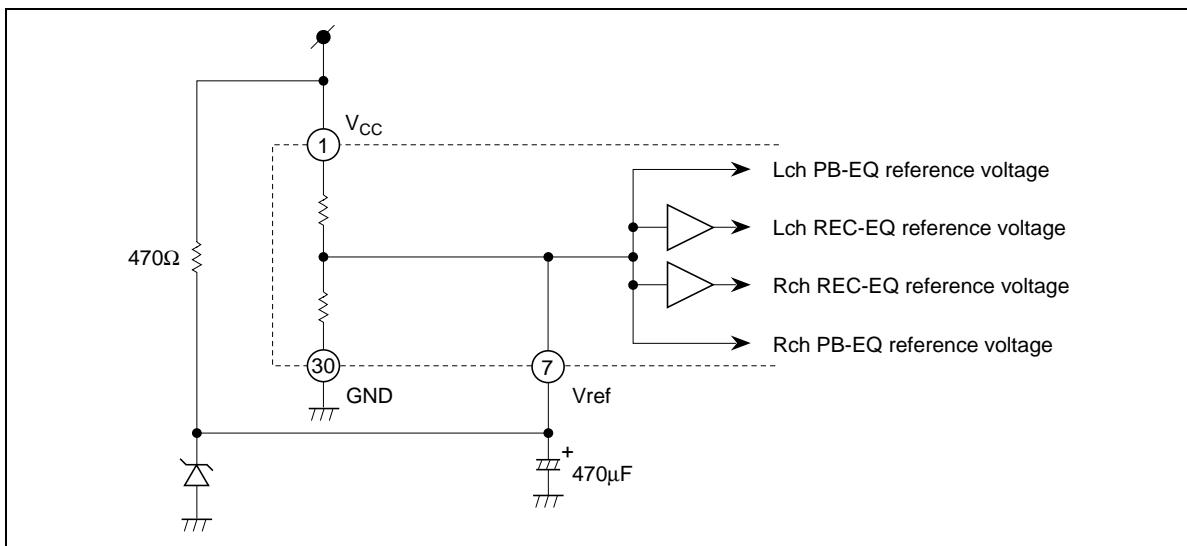

**Figure 1 Reference Voltage Circuit**

# HA12211NT

## Operating Mode Control

This IC provides fully electronic switching circuits. And each operating mode control is controlled by parallel data (DC voltage).

**Table 2 Threshold Voltage (V<sub>th</sub>)**

Pin No.	Lo	Mid	Hi	Unit	Test Condition
20, 21, 22, 23	0.0 to 2.5	—	4.0 to V <sub>cc</sub>	V	Input Pin
24	0.0 to 1.0	2.0 to 3.0	4.0 to V <sub>cc</sub>	V	Measure

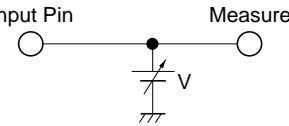

Note: 1. 20 to 23 pins are pulled down Lo level, and 24 pin is pulled to Mid level by the inside resistor 100kΩ.  
 2. Over shoot level and under shoot level of input signal must be the standardized. (High: V<sub>cc</sub>, Low: -0.2V)

## Block Diagram

This IC can be constructed for simple system which has little external parts by used the head serving both as Recording and Play back because of REC return SW built-in.

With output Hi-Z of REC-EQ and input muting, this IC is realized not only REC mute attenuation sufficiently but reducing pop noise in REC muting.

Note: Referring to Parallel Data Format also.

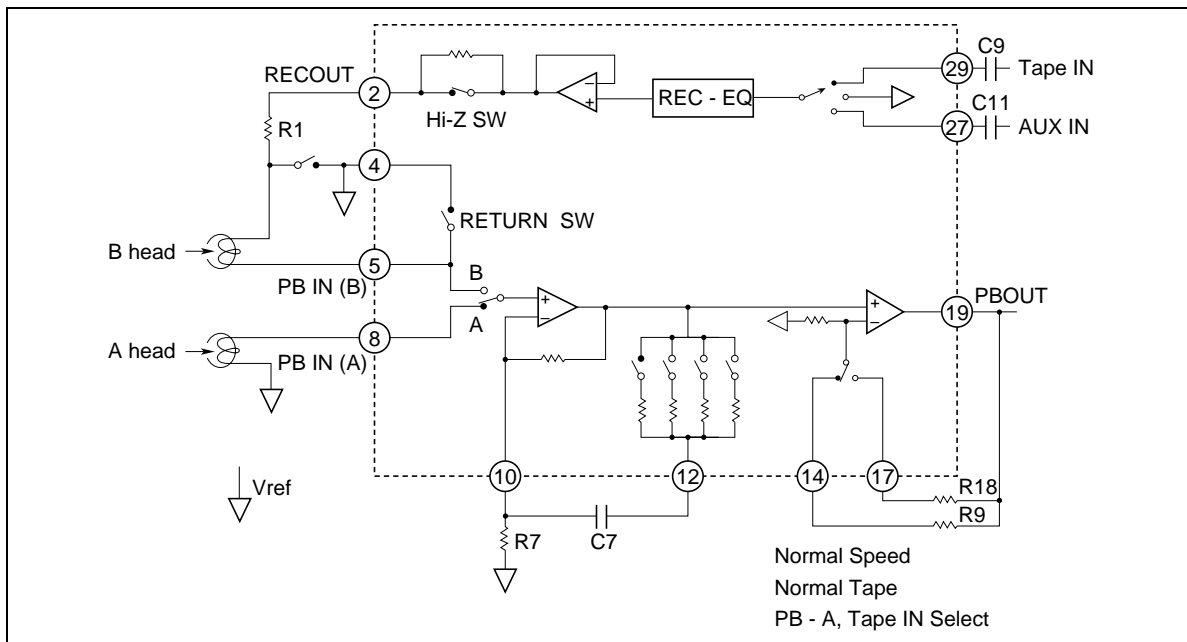

**Figure 2 Block Diagram (Lch)**



**Level Diagram**

It is the target that total play back output level is adjusted to 300mV; Dolby level, which the PB system gain in all is included of external amplifier's (Dolby IC etc.) as follows figure 3. Though A head adjustment is independent of B, select the value of R9, R18 adequately.

Regarding REC-EQ adjust the gain in front of input to this IC.

The level diagram at 1kHz is shown by figure 4.

- Note:
1. R1 needs the value more than 1kHz.
  2. Depending on the employed REC/PB head and test tape characteristics, there is rare case that the REC-EQ frequency characteristics of this IC can not be matched to the required characteristics because of built-in resistors which determined the REC-EQ parameters in this case, please inquire the responsible agent because of the adjustment of built-in resistors is necessary.

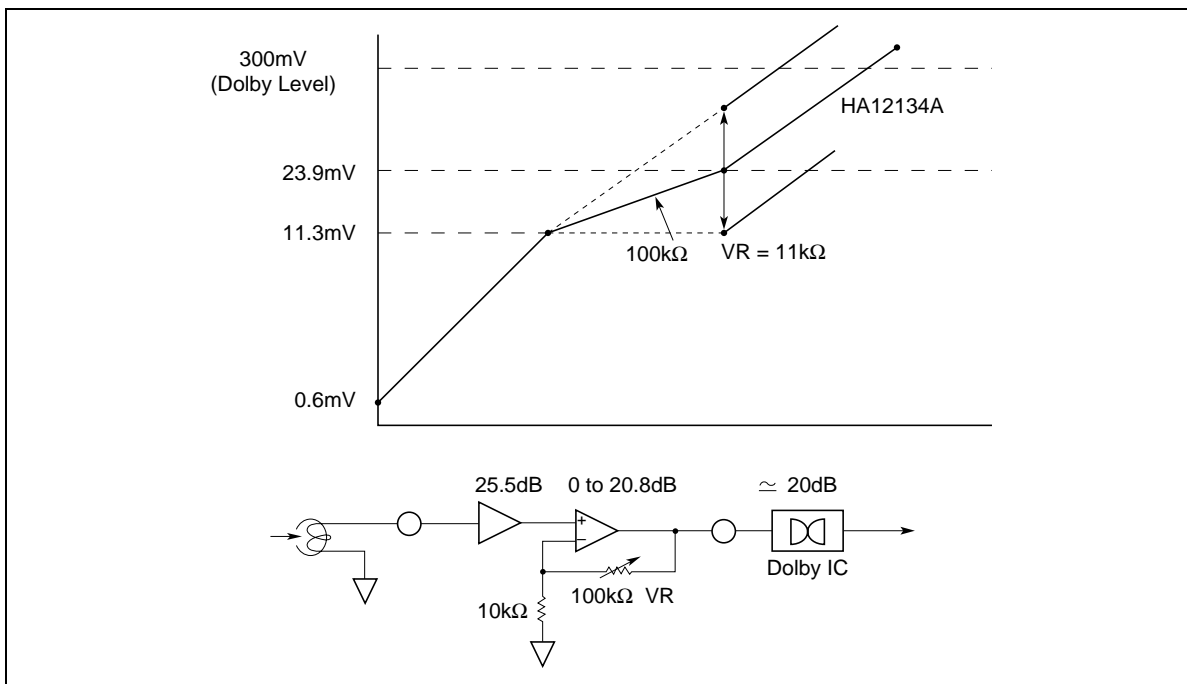

**Figure 3 PB Level Diagram (Normal Speed, Normal Tape, 1kHz)**

# HA12211NT

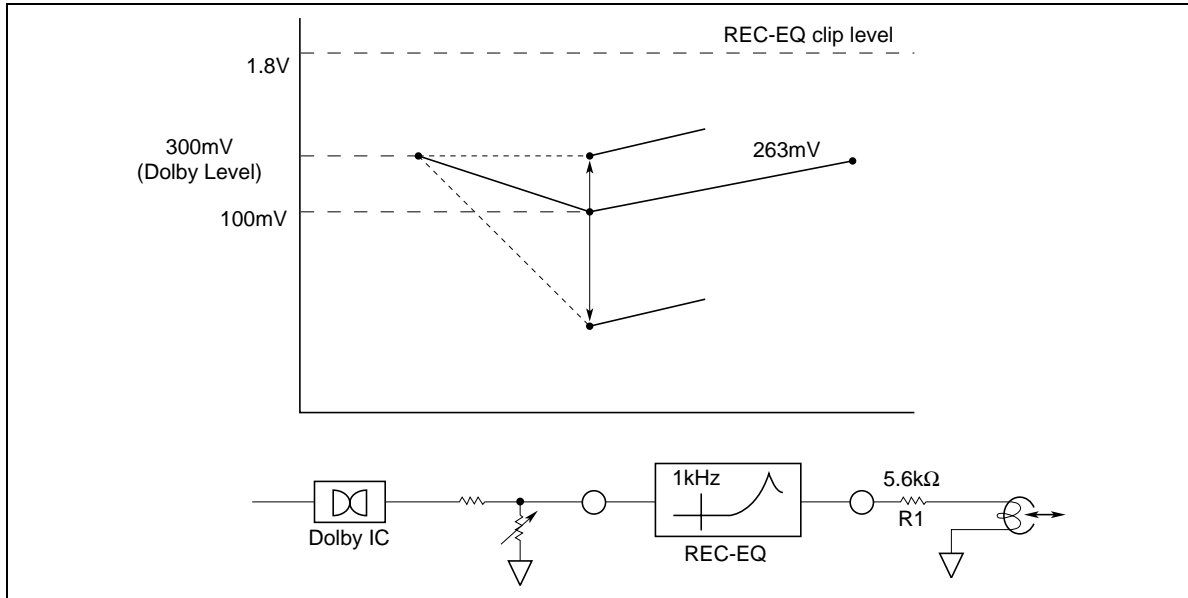

Figure 4 REC Level Diagram (Normal Speed, Normal Tape, 1kHz)

**Absolute Maximum Rating** ( $T_a = 25^\circ\text{C}$ )

<b>Item</b>	<b>Symbol</b>	<b>Rating</b>	<b>Unit</b>	<b>Note</b>
Max supply voltage	$V_{cc}$ max	16	V	
Power dissipation	$P_d$	500	mW	$T_a \leq 75^\circ\text{C}$
Operating temperature	$T_{opr}$	-40 to +75	$^\circ\text{C}$	
Storage temperature	$T_{stg}$	-55 to +125	$^\circ\text{C}$	
Operating voltage	$V_{opr}$	9.5 to 15	V	

# HA12211NT

**Electrical Characteristics** (Ta = 25°C, V<sub>CC</sub> = 10.5V, V<sub>ref</sub> = 5.25V, PB-EQ standard DC gain 55.9dB (R9, R10, R18, R19 = 11.0kΩ))

Item	Symbol	Test Condition				Application Terminal								
		Min	Typ	Max	Unit	IC Condition	A/B	HSP	A CrO2 B CrO2	REC	fin	Other	Input	Output
Quiescent current	I <sub>Q</sub>	16.0	22.8	32.0	mA	A	Norm	TYPE I	TYPE I	Mute	—	No signal	R	L
Logical threshold	V <sub>IL1</sub>	-0.2	—	2.5	V	—	—	—	—	—	—	—	1	COM
	V <sub>IL2</sub>	-0.2	—	1.0	V	—	—	—	—	—	—	—	20 to 23	24
	V <sub>IM</sub>	2.0	—	3.0	V	—	—	—	—	—	—	—	24	24
	V <sub>IH</sub>	4.0	—	V <sub>CC</sub>	V	—	—	—	—	—	—	—	20 to 24	24
PB-REC Crosstalk	CT PB/REC(1)	50	60	—	dB	A/B	Norm	TYPE I	TYPE I	Tape/ AUX	1k	*1	27/ 26/ 18	19
	CT PB/REC(2)	60	70	—	dB	A	Norm	TYPE I	TYPE I	Tape/ AUX	1k	*1	29 28	9 8 3 2
PB-EQ Gain	G <sub>V</sub> PB (1)	29.0	32.0	35.0	dB	A/B	Norm	TYPE I	TYPE I	Tape	1k	0.6	9/6 8/5 18 19	19
	G <sub>V</sub> PB (2)	25.0	28.0	31.0	dB	A/B	Norm	TYPE I	TYPE I	Tape	10k	0.6	9/6 8/5 18 19	19
	G <sub>V</sub> PB (3)	20.8	23.8	26.8	dB	A/B	Norm	TYPE II	TYPE II	Tape	10k	0.6	9/6 8/5 18 19	19
	G <sub>V</sub> PB (4)	19.4	22.4	25.4	dB	A/B	High	TYPE I	TYPE I	Tape	20k	0.6	9/6 8/5 18 19	19
	G <sub>V</sub> PB (5)	14.8	17.8	20.8	dB	A/B	High	TYPE III	TYPE III	Tape	20k	0.6	9/6 8/5 18 19	19
PB-EQ Maximum output	V <sub>omax</sub> PB	0.3	2.0	—	Vrms	A/B	Norm	TYPE I	TYPE I	Tape	1k	—	THD=1% <sup>2</sup>	9/6 8/5 18 19
PB-EQ THD	THD PB	—	0.1	0.5	%	A/B	Norm	TYPE I	TYPE I	Tape	1k	0.6	9/6 8/5 18 19	19
PB-EQ Noise voltage	V <sub>N</sub> PB	—	38	70	μVrms	A/B	Norm	TYPE I	TYPE I	Tape	—	—	Rg=820Ω, DIN-AUDIO	9/6 8/5 18 19
PB-EQ Channel separation	CT R/L (1)	50	60	—	dB	A/B	Norm	TYPE I	TYPE I	Tape	1k	*1	8/5 9/6 18 19	19
PB-EQ Crosstalk	CT A/B	60	70	—	dB	A	Norm	TYPE I	TYPE I	Tape	1k	*1	11 10 18 19	19
						B							9	8

Note: 1. Large level without clipping

2. V<sub>CC</sub> = 9.5V, V<sub>ref</sub> = 4.75V, R9, R10, R18, R19 = 56kΩ

**Electrical Characteristics** (Ta = 25°C, V<sub>cc</sub> = 10.5V, V<sub>ref</sub> = 5.25V, EQIN standard level = 100mV = 0dB) (cont)

Item	Symbol	Min	Typ	Max	Unit	A/B	HSP	A CrO2 B CrO2	REC	fin	Vin	Application Terminal				
												IC Condition	Input	Output	COM	
REC-EQ Frequency response Normal speed TYPE I	G <sub>v</sub> REC-NN 1	6.7	8.2	9.7	dB	A	Norm	TYPE I	TYPE I	Tape/ 1k AUX	10	R	L	R	L	COM
	G <sub>v</sub> REC-NN 2	9.3	11.3	13.3	dB	A	Norm	TYPE I	TYPE I	Tape/ 5k AUX	10	26/ 27/ 3	28 29	26/ 27/ 3	28 29	2
	G <sub>v</sub> REC-NN 3	17.3	20.3	23.3	dB	A	Norm	TYPE I	TYPE I	Tape/ 10k AUX	10	26/ 27/ 3	28 29	26/ 27/ 3	28 29	2
REC-EQ Frequency response Normal speed TYPE II	G <sub>v</sub> REC-NC 1	9.8	11.3	12.8	dB	A	Norm	TYPE I	TYPE II	Tape/ 1k AUX	10	26/ 27/ 3	28 29	26/ 27/ 3	28 29	2
	G <sub>v</sub> REC-NC 2	14.2	16.2	18.2	dB	A	Norm	TYPE I	TYPE II	Tape/ 5k AUX	10	26/ 27/ 3	28 29	26/ 27/ 3	28 29	2
	G <sub>v</sub> REC-NC 3	20.5	23.5	26.5	dB	A	Norm	TYPE I	TYPE II	Tape/ 10k AUX	10	26/ 27/ 3	28 29	26/ 27/ 3	28 29	2
REC-EQ Frequency response High speed TYPE I	G <sub>v</sub> REC-HN 1	7.0	8.5	10.0	dB	A	High	TYPE I	TYPE I	Tape/ 2k AUX	10	26/ 27/ 3	28 29	26/ 27/ 3	28 29	2
	G <sub>v</sub> REC-HN 2	10.9	12.9	14.9	dB	A	High	TYPE I	TYPE I	Tape/ 10k AUX	10	26/ 27/ 3	28 29	26/ 27/ 3	28 29	2
	G <sub>v</sub> REC-HN 3	18.7	21.7	24.7	dB	A	High	TYPE I	TYPE I	Tape/ 20k AUX	10	26/ 27/ 3	28 29	26/ 27/ 3	28 29	2
REC-EQ Frequency response High speed TYPE II	G <sub>v</sub> REC-HC 1	11.0	12.5	14.0	dB	A	High	TYPE I	TYPE II	Tape/ 2k AUX	10	26/ 27/ 3	28 29	26/ 27/ 3	28 29	2
	G <sub>v</sub> REC-HC 2	16.2	18.2	20.2	dB	A	High	TYPE I	TYPE II	Tape/ 10k AUX	10	26/ 27/ 3	28 29	26/ 27/ 3	28 29	2
	G <sub>v</sub> REC-HC 3	23.7	26.7	29.7	dB	A	High	TYPE I	TYPE II	Tape/ 20k AUX	10	26/ 27/ 3	28 29	26/ 27/ 3	28 29	2
REC-EQ Channel separation	CT R/L (2)	50	60	—	dB	A	Norm	TYPE I	TYPE I	Tape/ 1k AUX	*1	26/ 27/ 3	28 29	26/ 27/ 3	28 29	2
REC-EQ Crosstalk	CT Tape/AUX	50	60	—	dB	A	Norm	TYPE I	TYPE I	Tape/ 1k AUX	*1	26/ 27/ 3	28 29	26/ 27/ 3	28 29	2
REC-EQ Attenuation	R-MUTE ATT	70	80	—	dB	A	Norm	TYPE I	TYPE I	Mute	1k	26/ 27/ 3	28 29	26/ 27/ 3	28 29	2
REC-EQ Maximum output	Vomax REC	1.2	1.8	—	Vrms	A	Norm	TYPE I	TYPE I	Tape/ 1k AUX	—	THD=1%*2	26/ 27/ 3	28 29	26/ 27/ 3	2
REC-EQ THD	THD REC	—	0.35	0.7	%	A	Norm	TYPE I	TYPE I	Tape/ 1k AUX	100	26/ 27/ 3	28 29	26/ 27/ 3	28 29	2
REC-EQ S/N	S/N REC	52	56	—	dB	A	Norm	TYPE I	TYPE I	Tape/ 1k AUX	—	Rg=5.1kΩ, A-WTG	26/ 27/ 3	28 29	26/ 27/ 3	2

Note: 1. Large level without clipping  
2. V<sub>cc</sub> = 9.5V, V<sub>ref</sub> = 4.75V

# HA12211NT

## Test Circuit

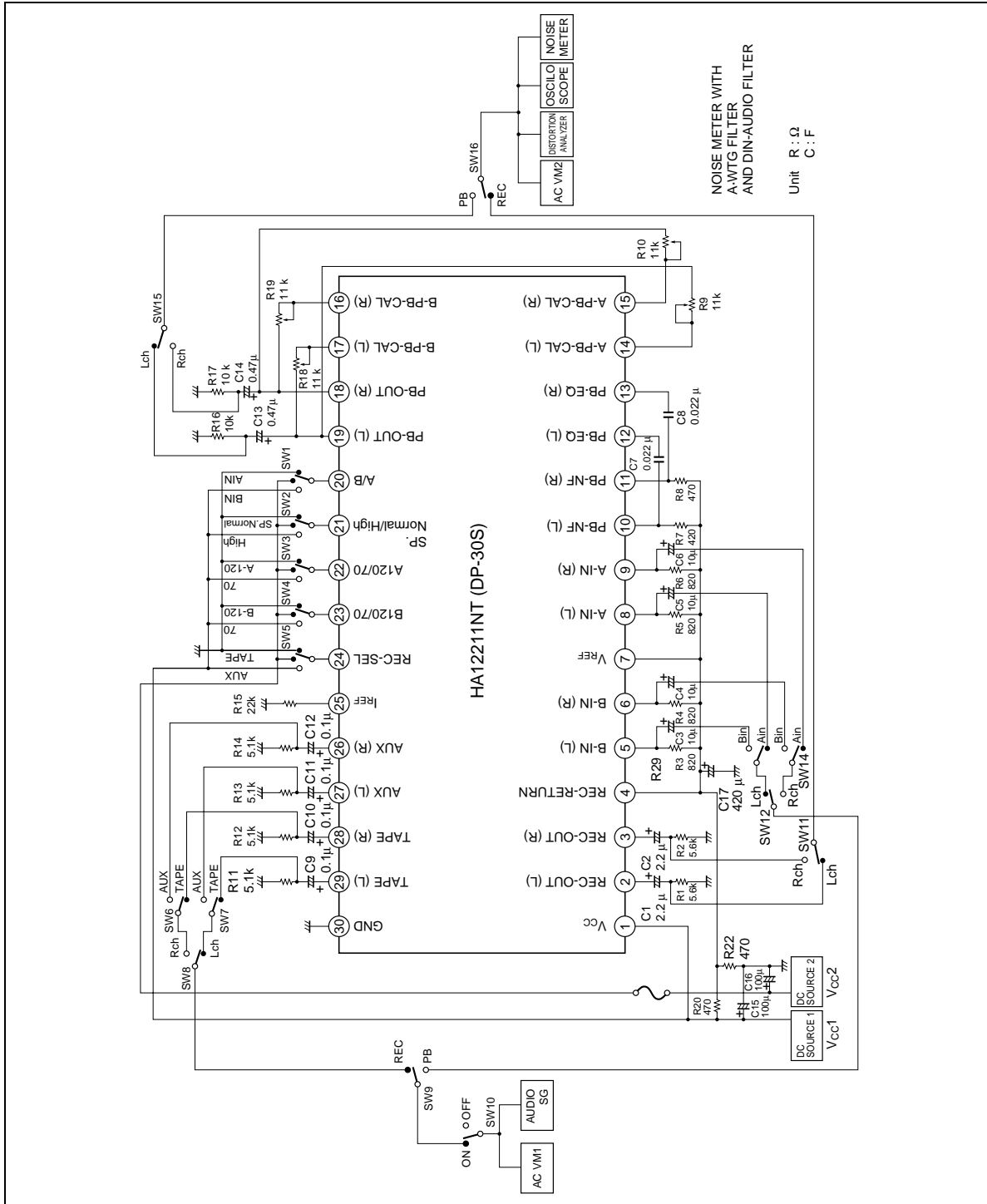

Characteristics Curve

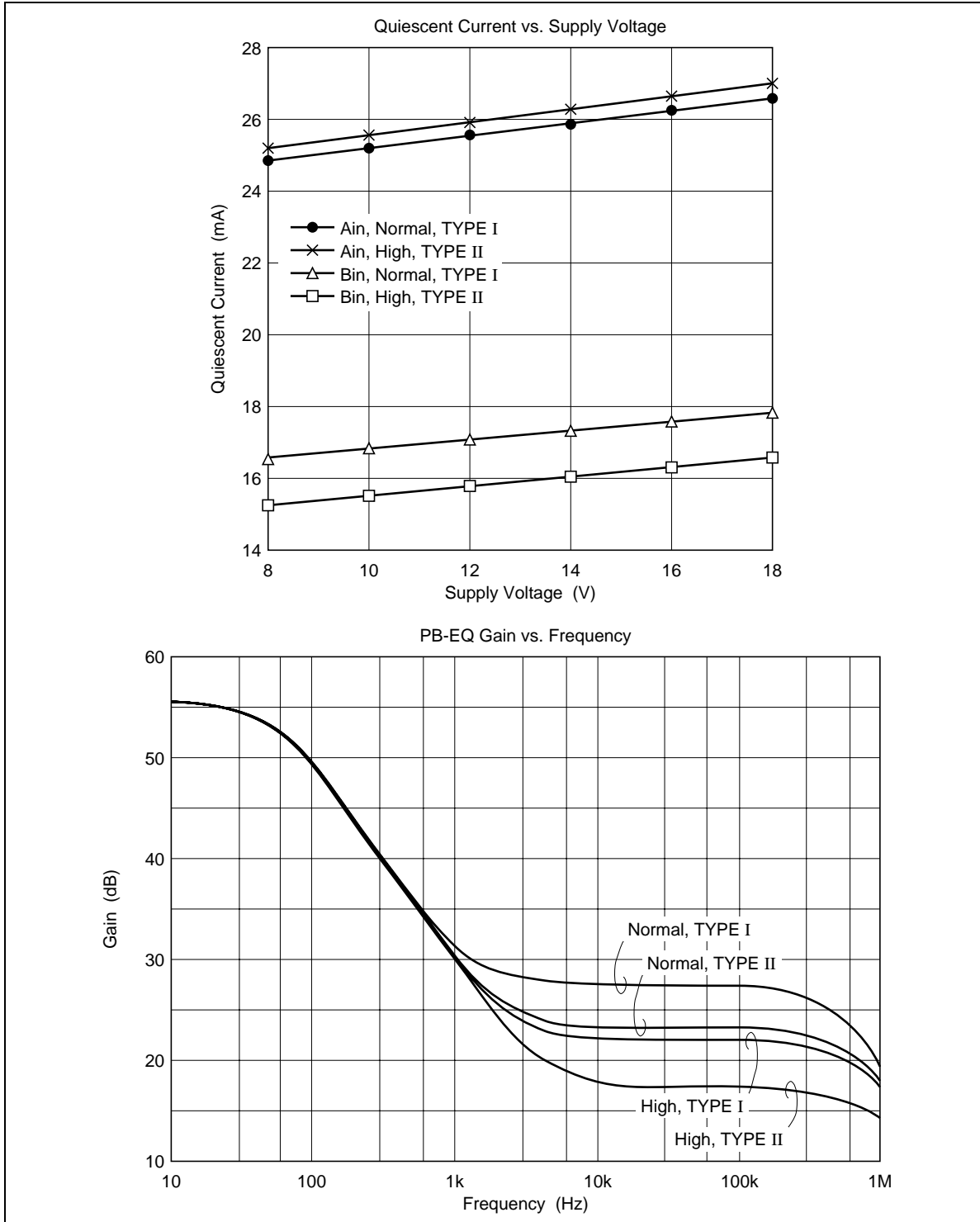

# HA12211NT

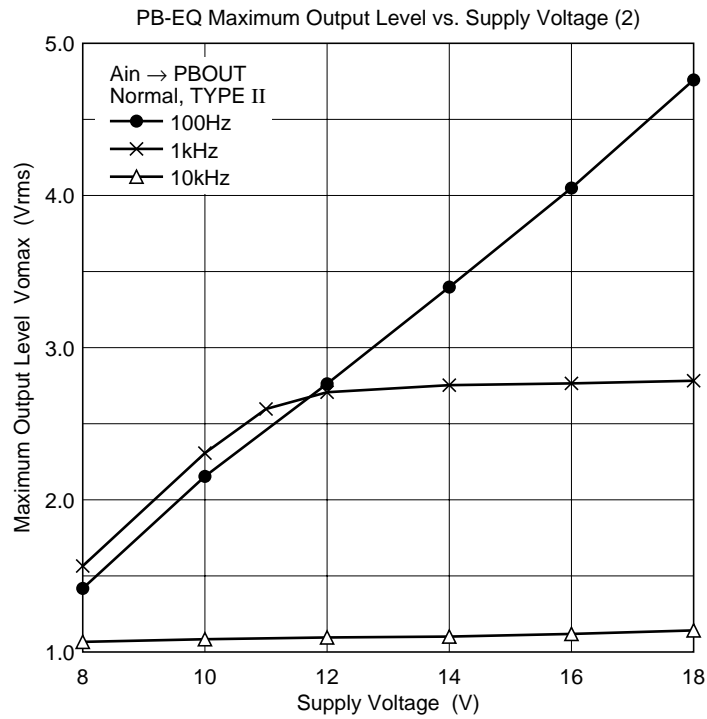
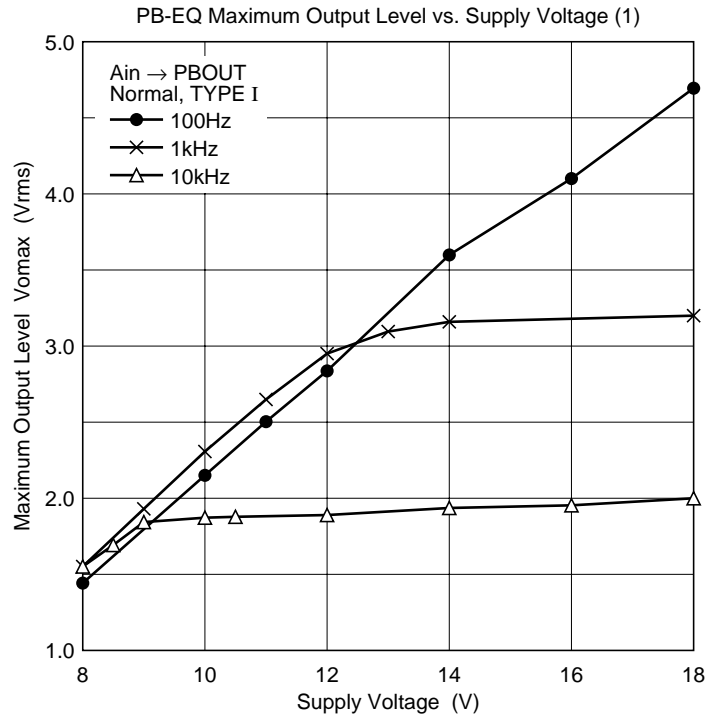



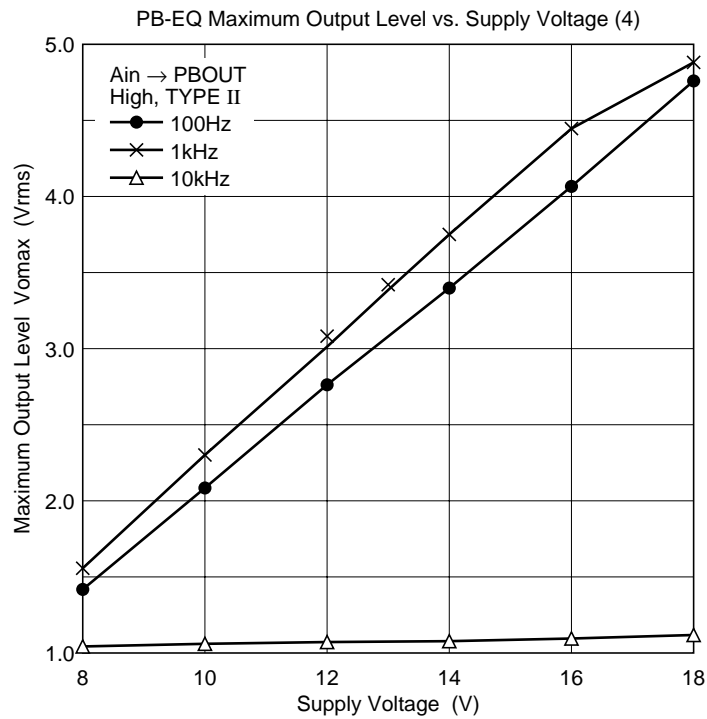
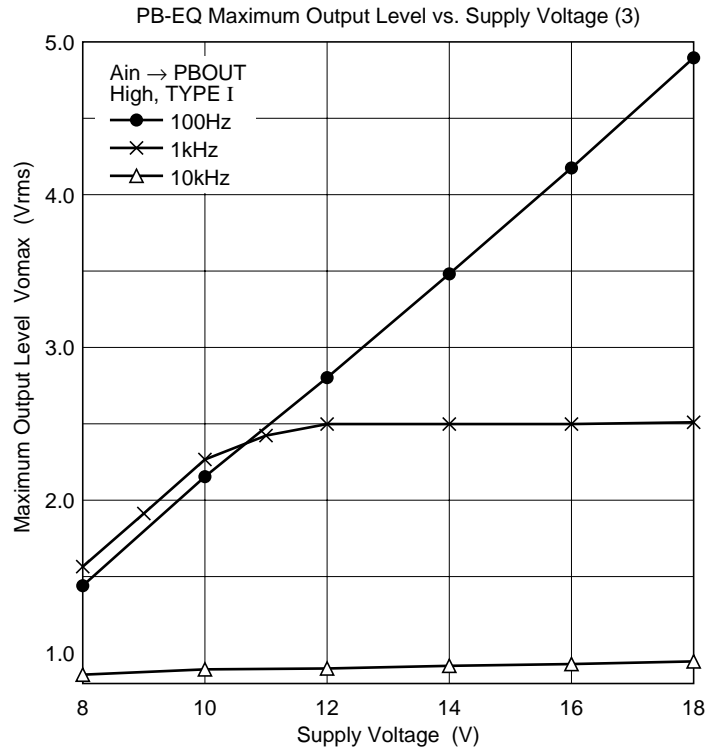

# HA12211NT

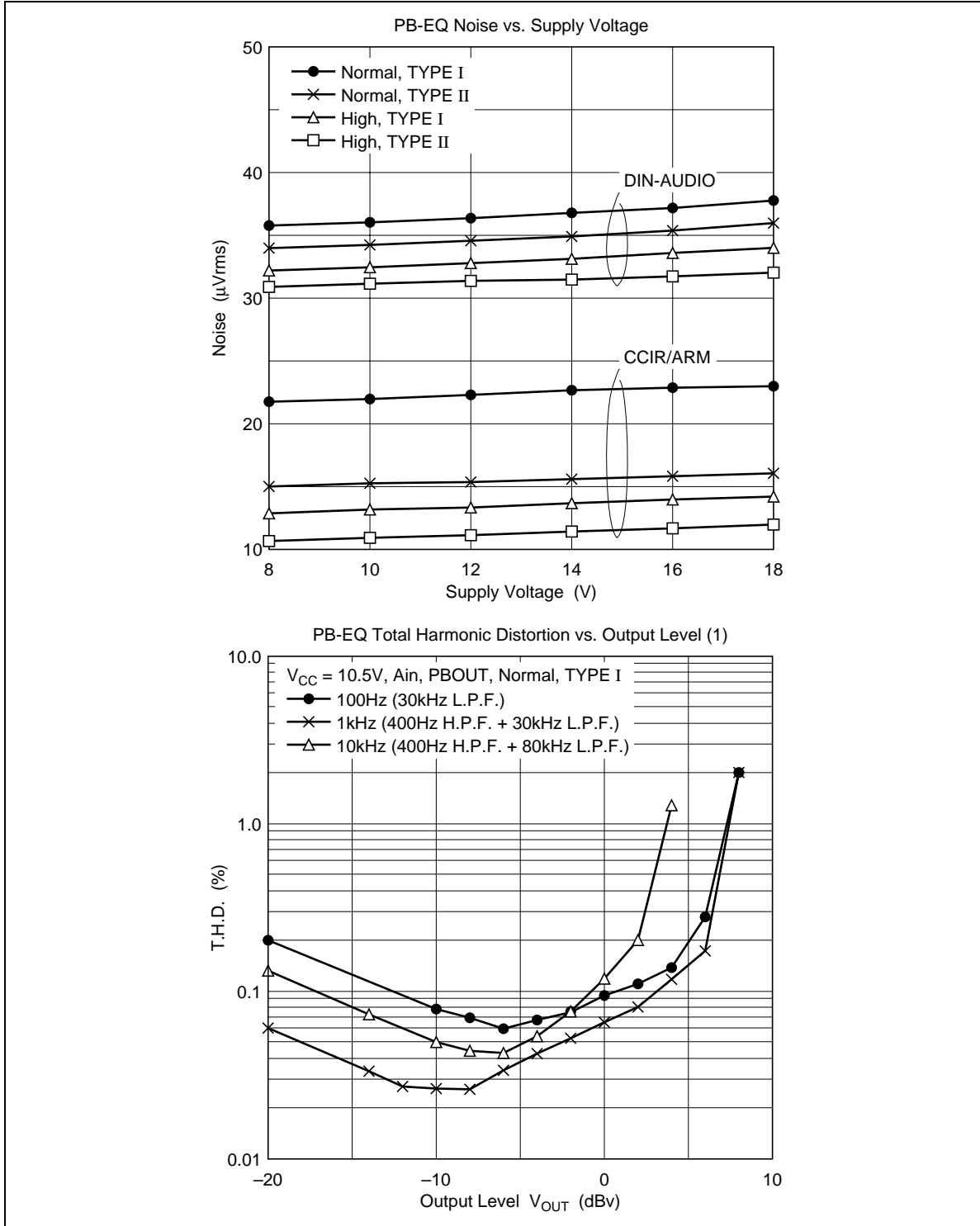

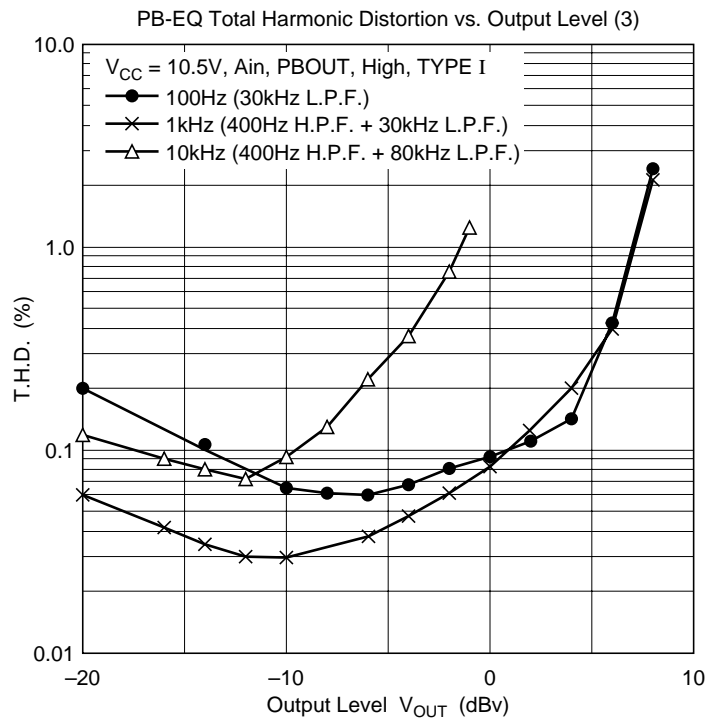
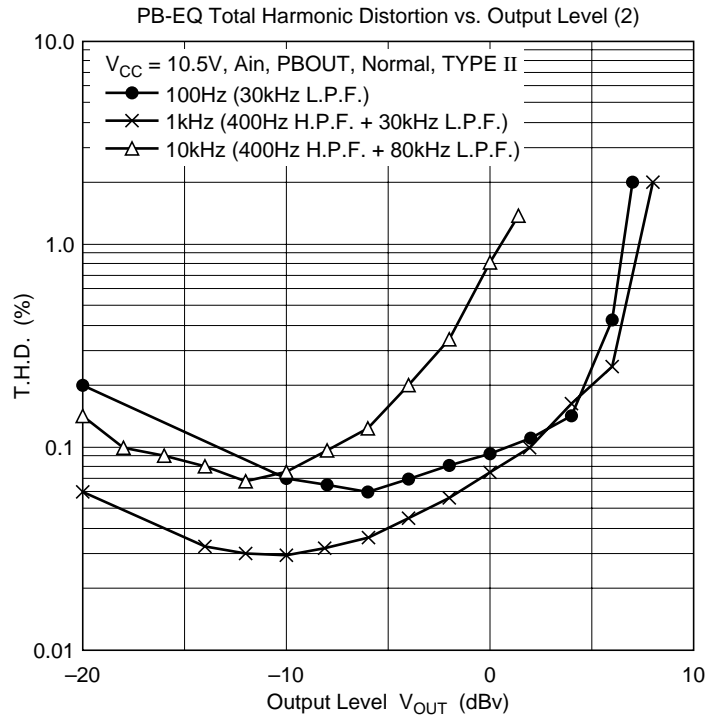

# HA12211NT

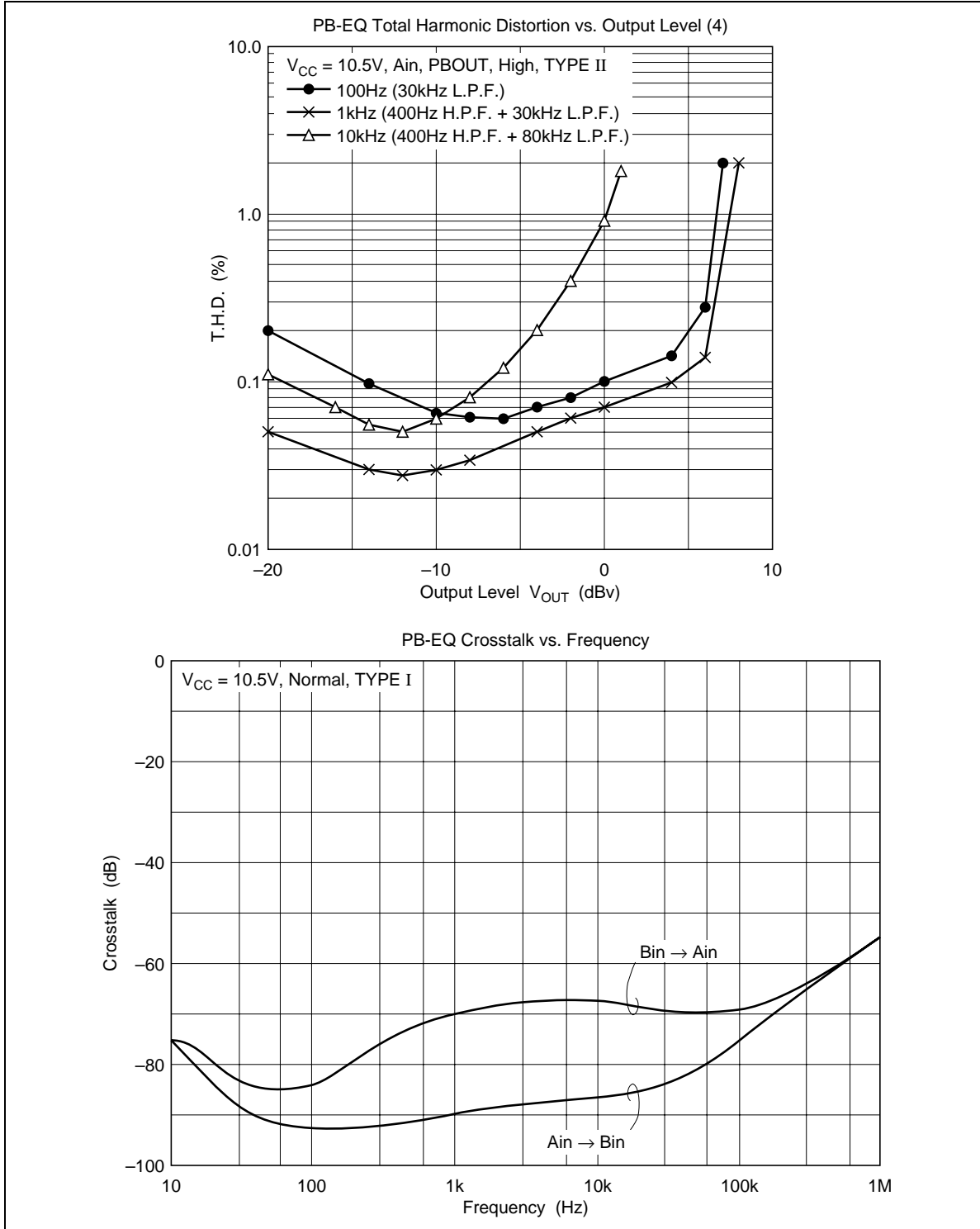

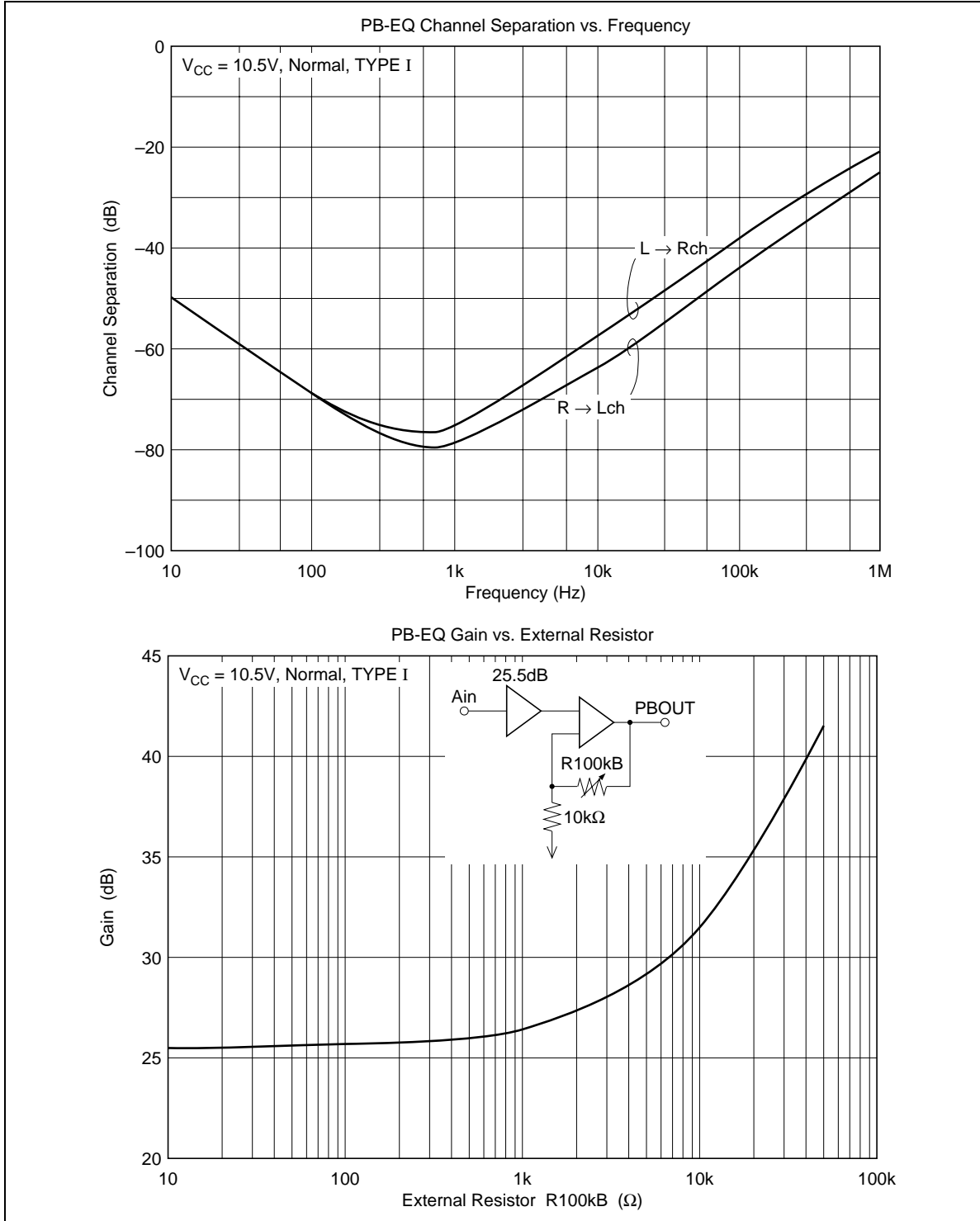

# HA12211NT

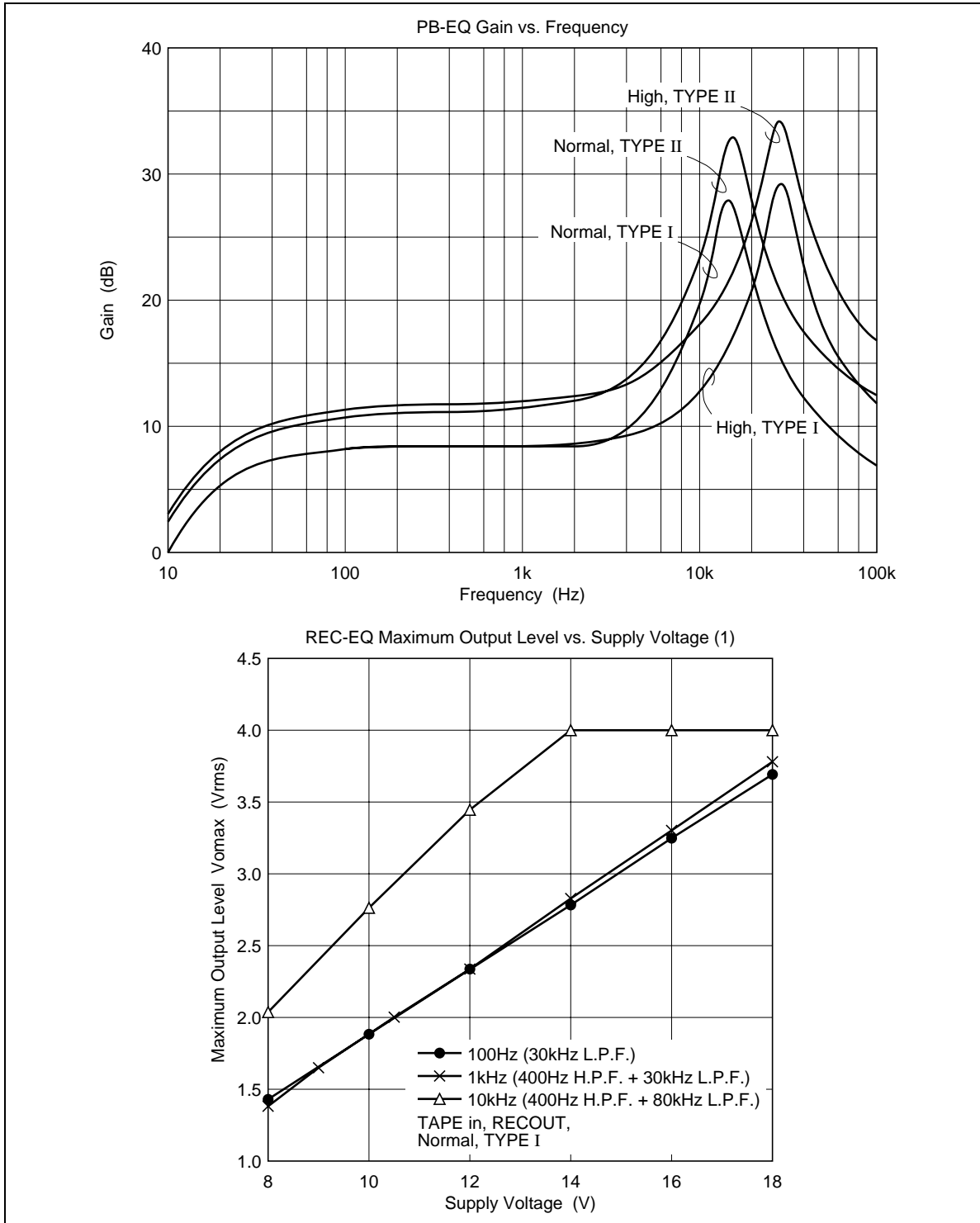

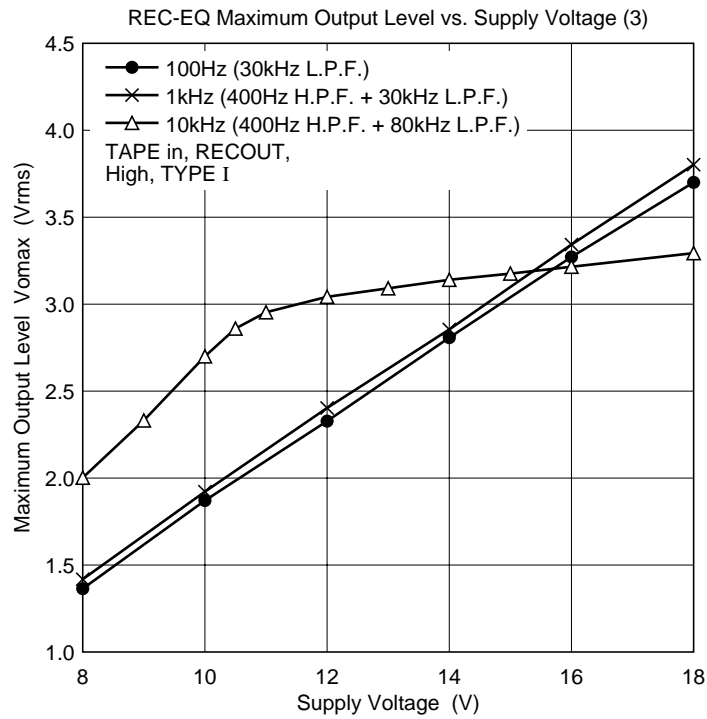
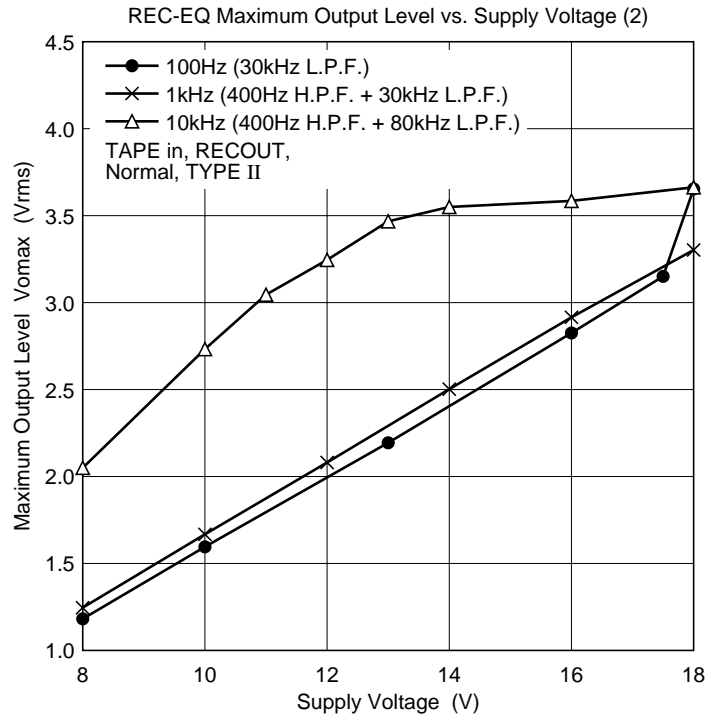

# HA12211NT

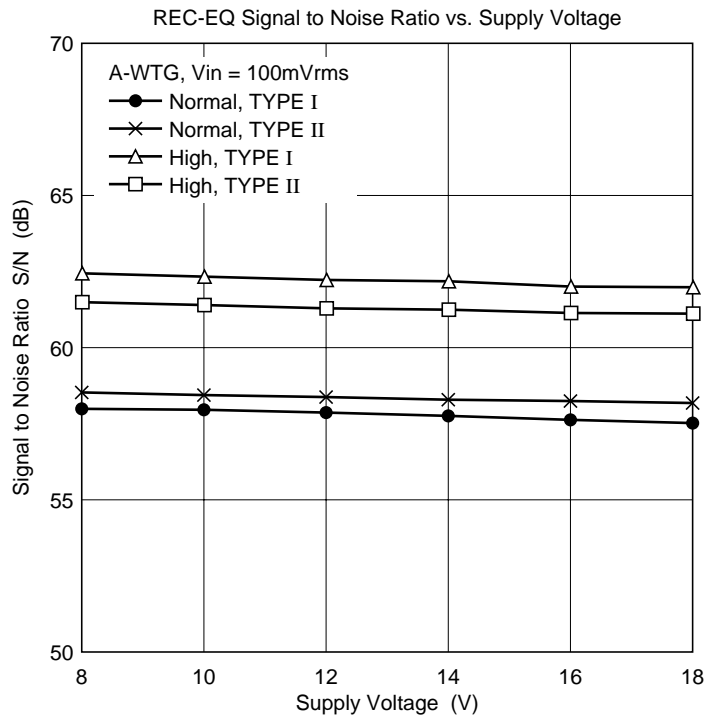
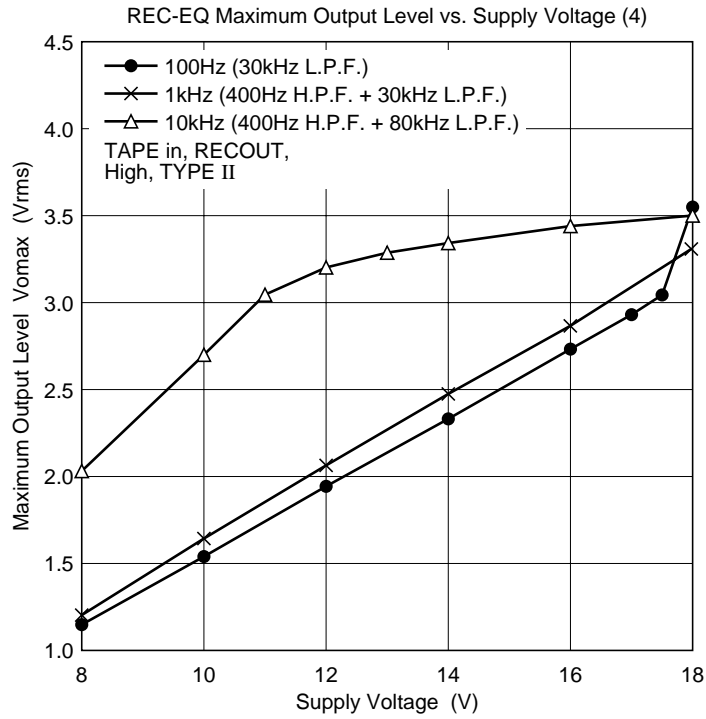



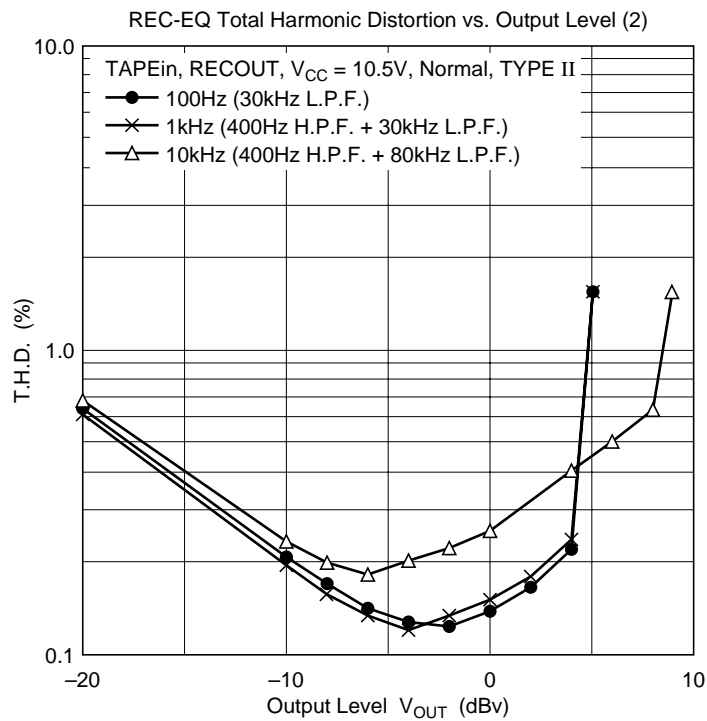
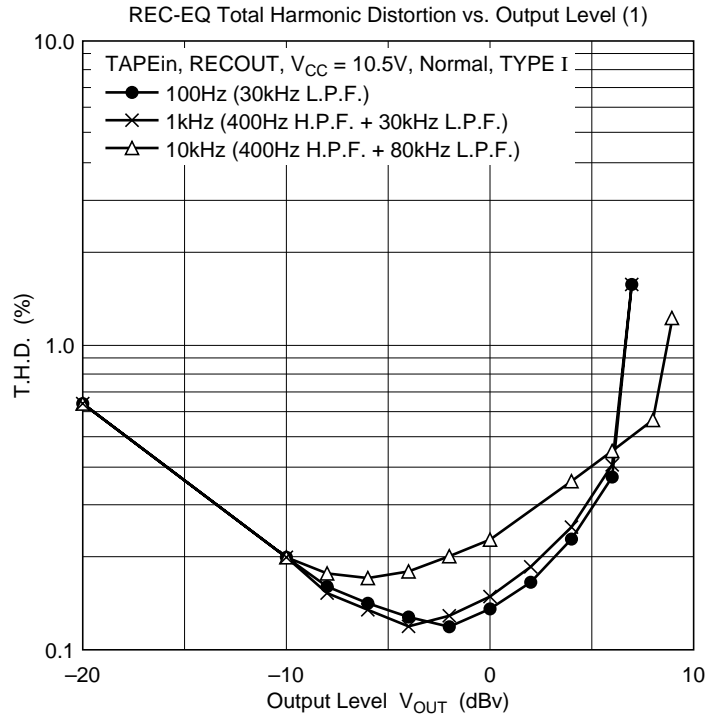

# HA12211NT

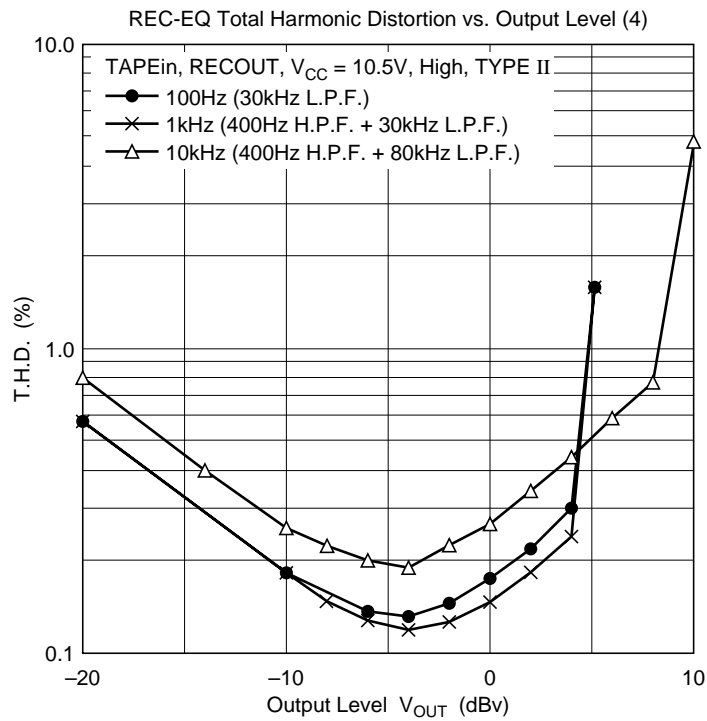
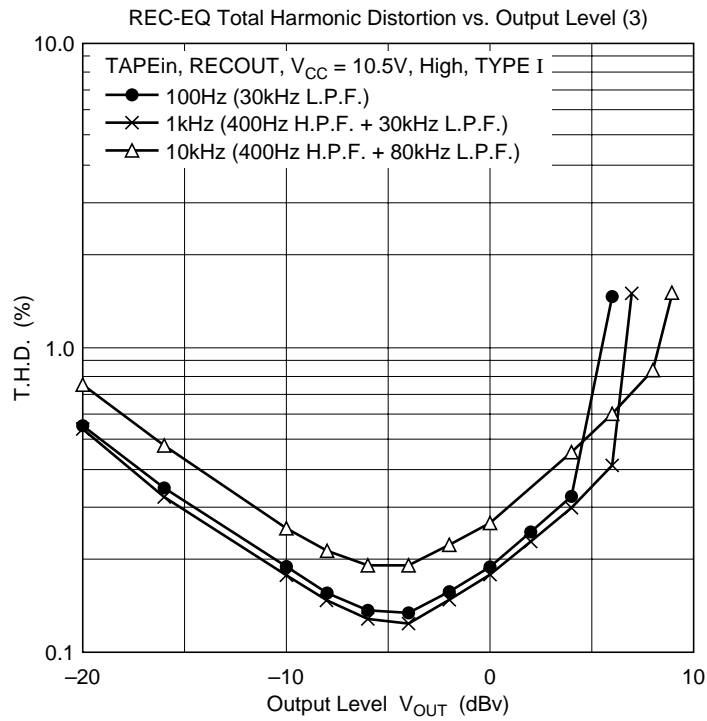

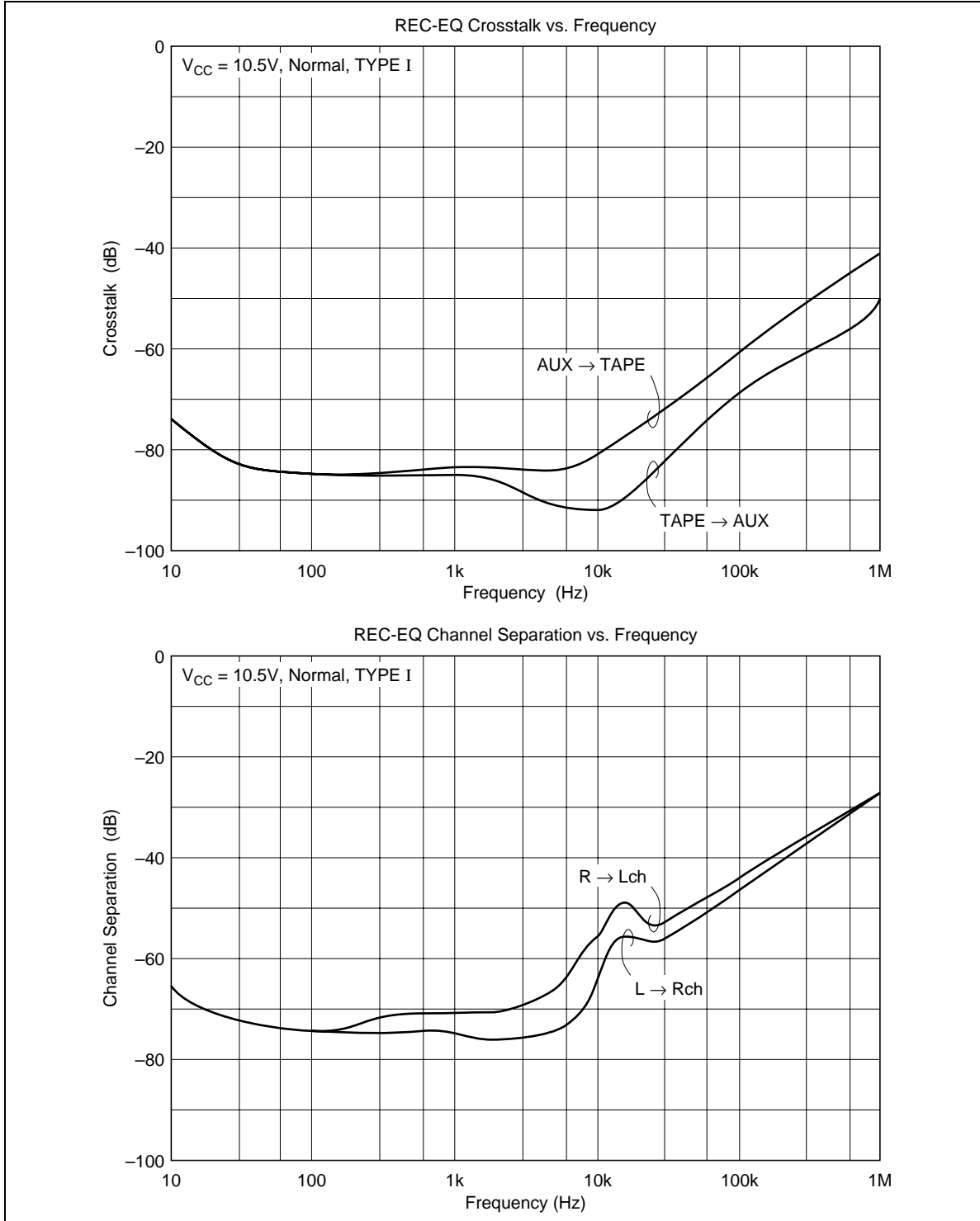

# HA12211NT

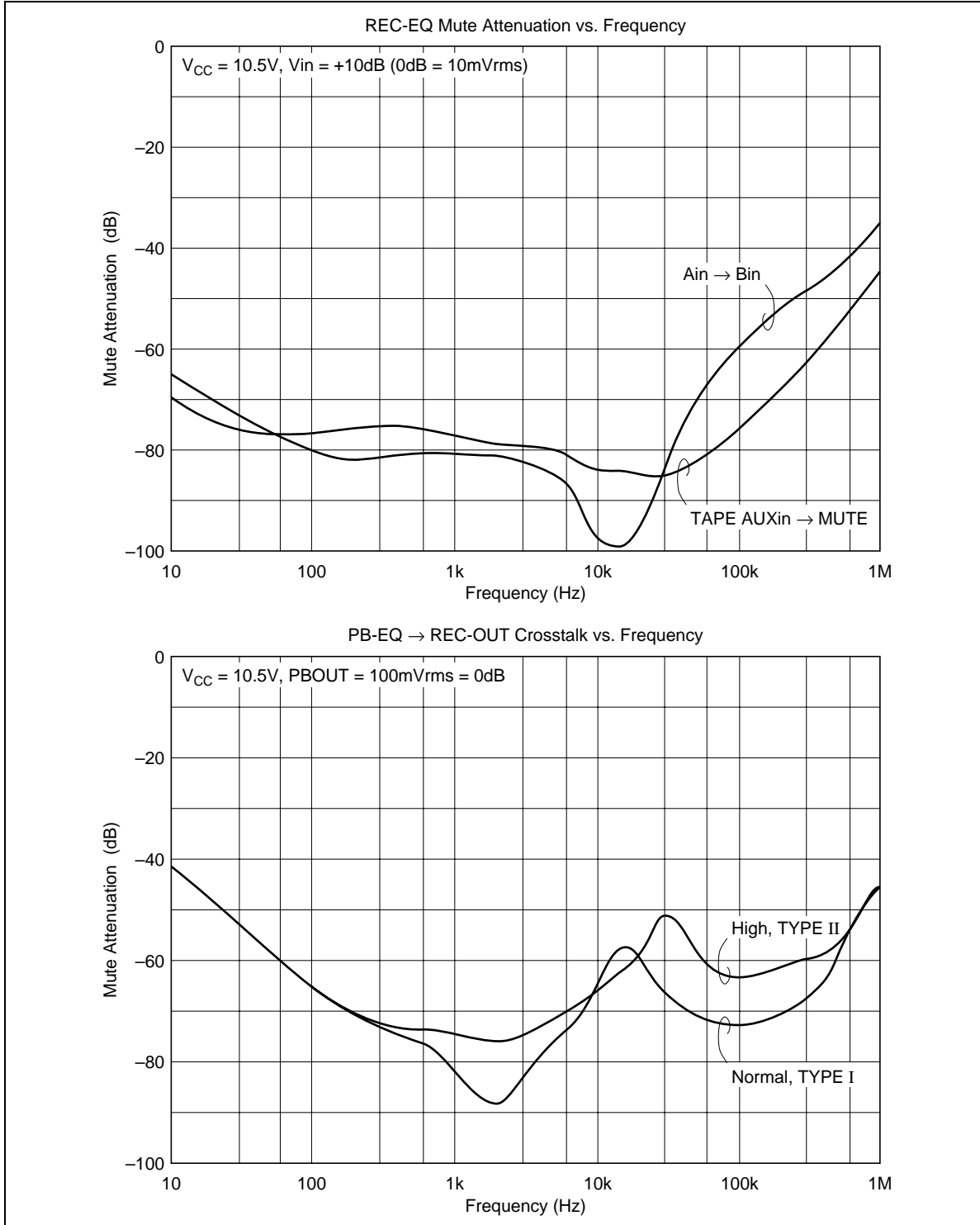

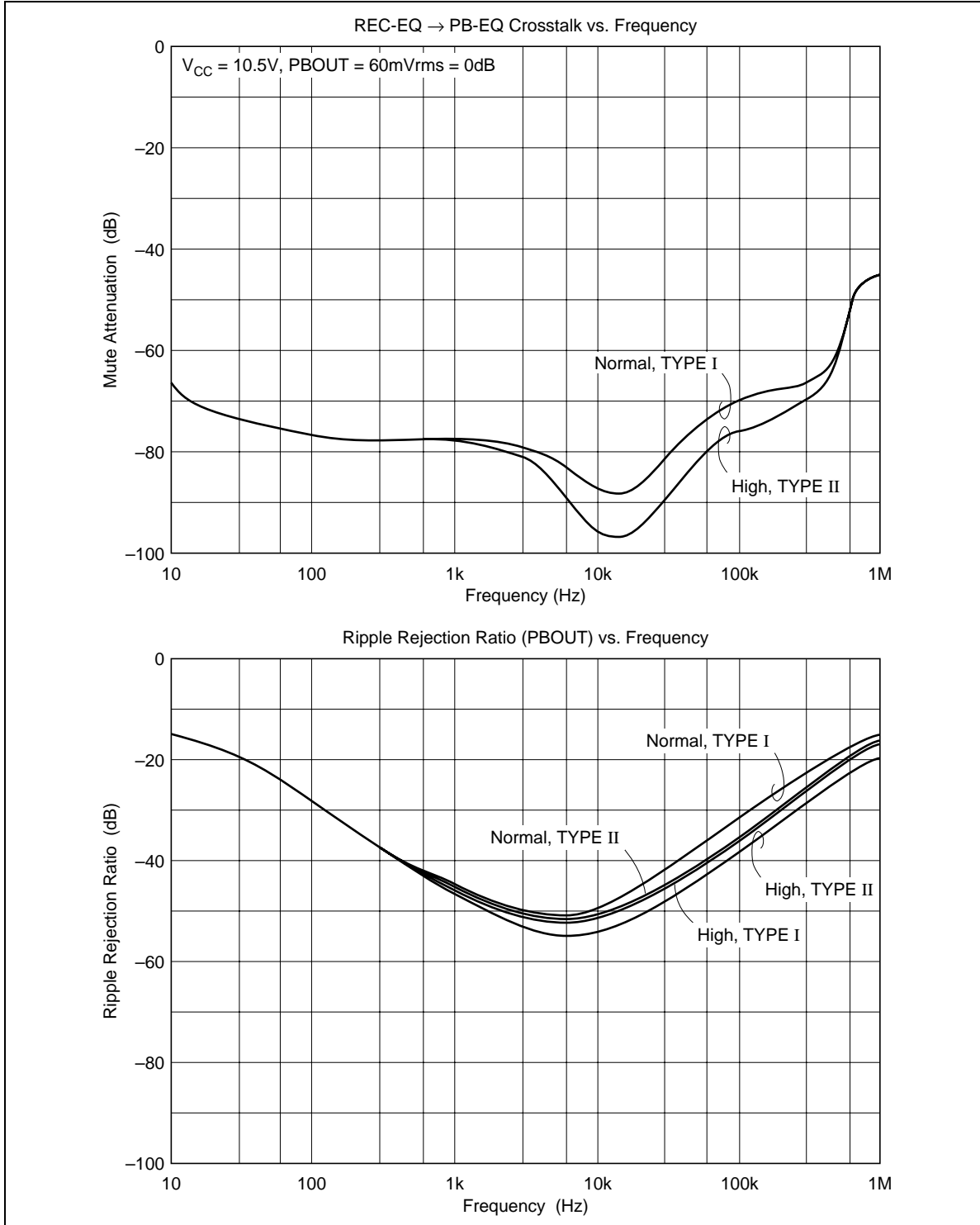

# HA12211NT

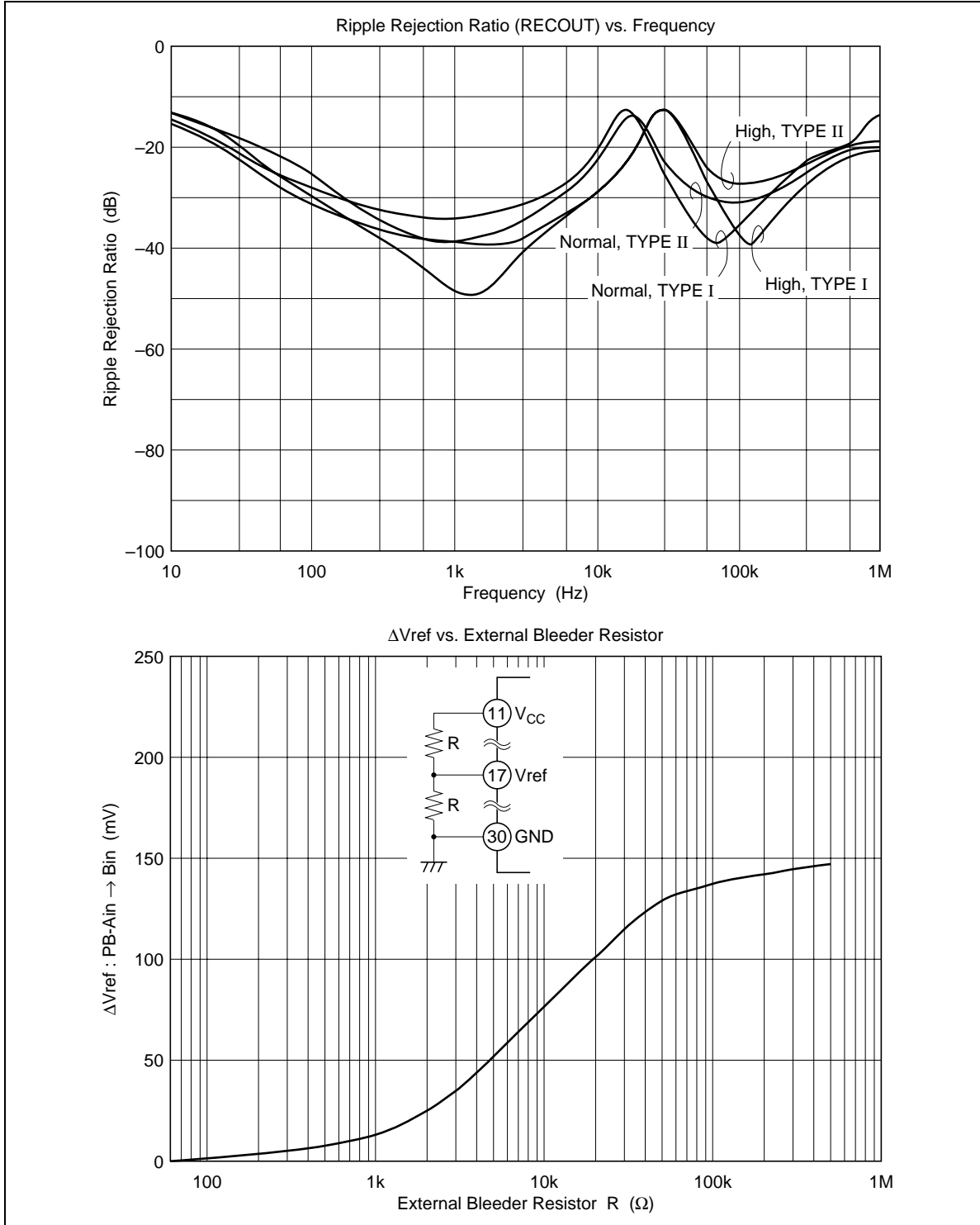

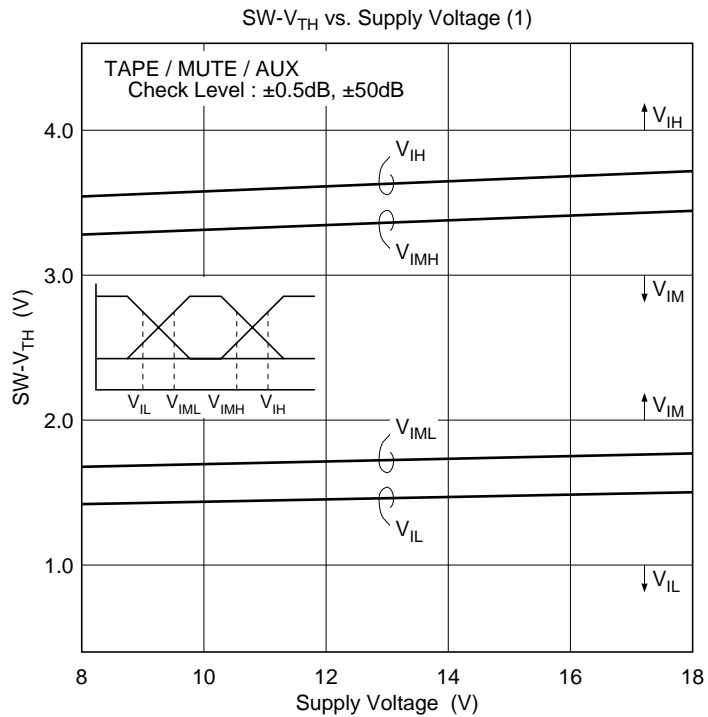
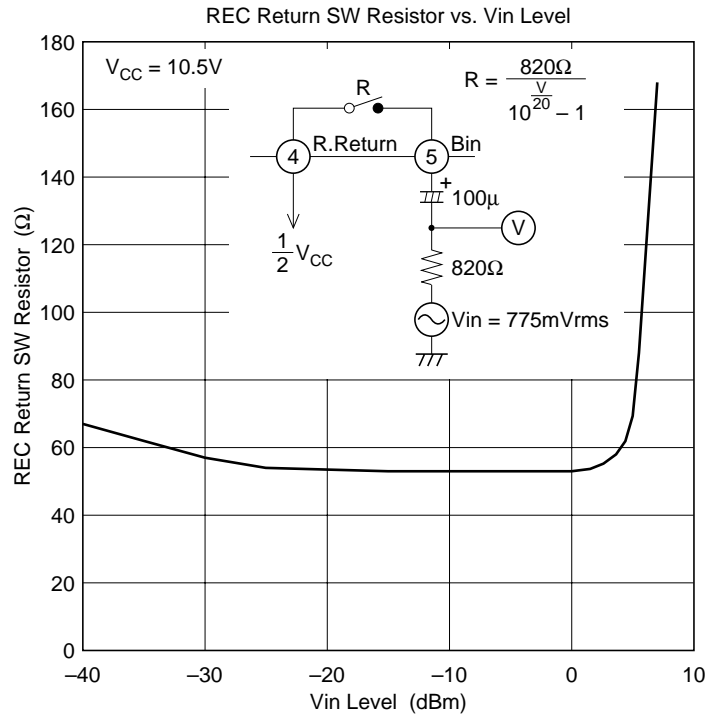

# HA12211NT

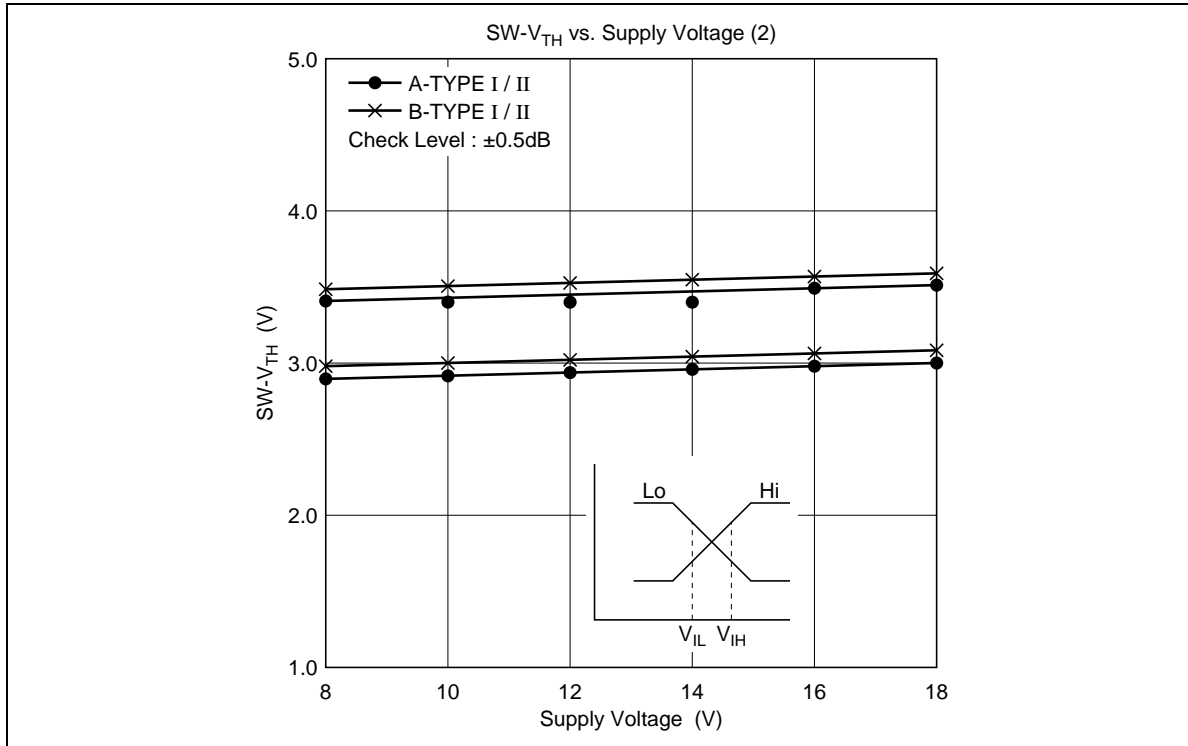



Package Dimensions

Unit: mm

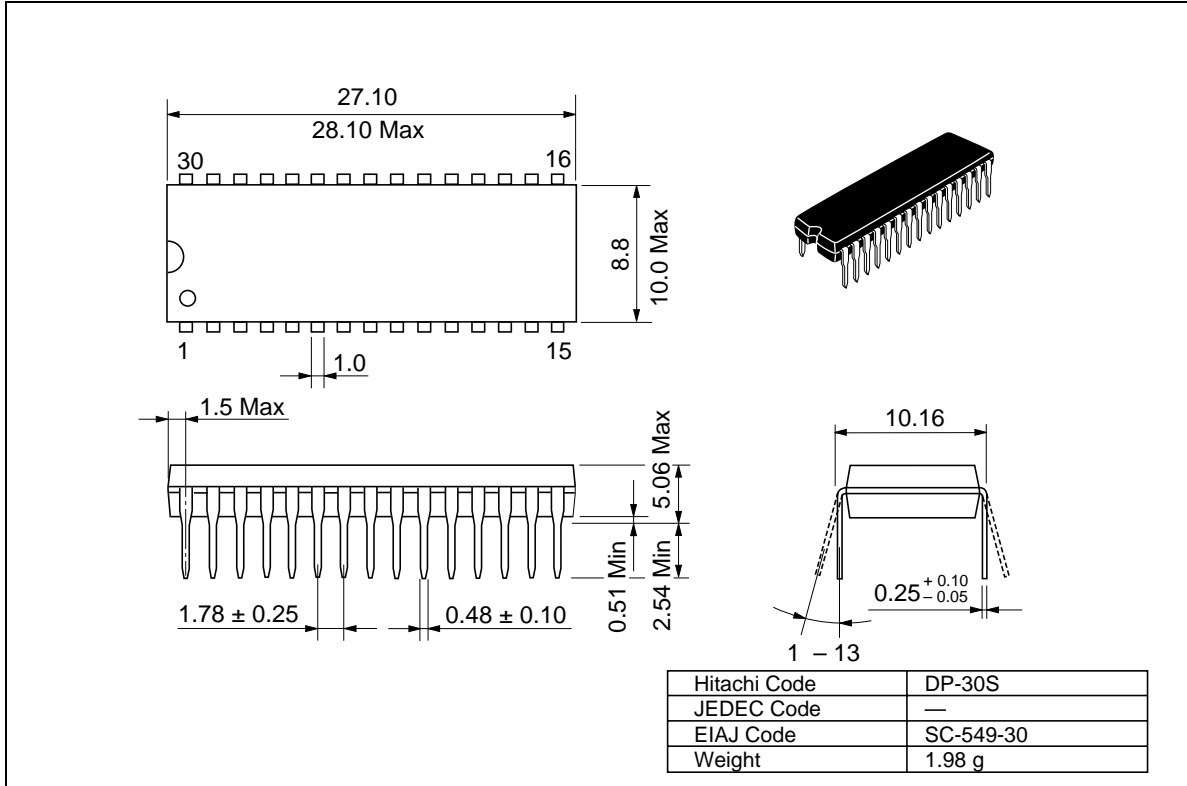

---

## HA12211NT

---

### Disclaimer

1. Hitachi neither warrants nor grants licenses of any rights of Hitachi's or any third party's patent, copyright, trademark, or other intellectual property rights for information contained in this document. Hitachi bears no responsibility for problems that may arise with third party's rights, including intellectual property rights, in connection with use of the information contained in this document.
2. Products and product specifications may be subject to change without notice. Confirm that you have received the latest product standards or specifications before final design, purchase or use.
3. Hitachi makes every attempt to ensure that its products are of high quality and reliability. However, contact Hitachi's sales office before using the product in an application that demands especially high quality and reliability or where its failure or malfunction may directly threaten human life or cause risk of bodily injury, such as aerospace, aeronautics, nuclear power, combustion control, transportation, traffic, safety equipment or medical equipment for life support.
4. Design your application so that the product is used within the ranges guaranteed by Hitachi particularly for maximum rating, operating supply voltage range, heat radiation characteristics, installation conditions and other characteristics. Hitachi bears no responsibility for failure or damage when used beyond the guaranteed ranges. Even within the guaranteed ranges, consider normally foreseeable failure rates or failure modes in semiconductor devices and employ systemic measures such as fail-safes, so that the equipment incorporating Hitachi product does not cause bodily injury, fire or other consequential damage due to operation of the Hitachi product.
5. This product is not designed to be radiation resistant.
6. No one is permitted to reproduce or duplicate, in any form, the whole or part of this document without written approval from Hitachi.
7. Contact Hitachi's sales office for any questions regarding this document or Hitachi semiconductor products.

### Sales Offices

---

# HITACHI

**Hitachi, Ltd.**

Semiconductor & Integrated Circuits.

Nippon Bldg., 2-6-2, Ohte-machi, Chiyoda-ku, Tokyo 100-0004, Japan

Tel: Tokyo (03) 3270-2111 Fax: (03) 3270-5109

URL      NorthAmerica      : <http://semiconductor.hitachi.com/>  
             Europe                 : <http://www.hitachi-eu.com/hel/ecg>  
             Asia                         : <http://sicapac.hitachi-asia.com>  
             Japan                        : <http://www.hitachi.co.jp/Sicd/indx.htm>

#### For further information write to:

Hitachi Semiconductor  
(America) Inc.  
179 East Tasman Drive,  
San Jose, CA 95134  
Tel: <1> (408) 433-1990  
Fax: <1> (408) 433-0223

Hitachi Europe GmbH  
Electronic Components Group  
Dornacher StraÙe 3  
D-85622 Feldkirchen, Munich  
Germany  
Tel: <49> (89) 9 9180-0  
Fax: <49> (89) 9 29 30 00

Hitachi Europe Ltd.  
Electronic Components Group.  
Whitebrook Park  
Lower Cookham Road  
Maidenhead  
Berkshire SL6 8YA, United Kingdom  
Tel: <44> (1628) 585000  
Fax: <44> (1628) 585160

Hitachi Asia Ltd.  
Hitachi Tower  
16 Collyer Quay #20-00,  
Singapore 049318  
Tel : <65>-538-6533/538-8577  
Fax : <65>-538-6933/538-3877  
URL : <http://www.hitachi.com.sg>

Hitachi Asia Ltd.  
(Taipei Branch Office)  
4/F, No. 167, Tun Hwa North Road,  
Hung-Kuo Building,  
Taipei (105), Taiwan  
Tel : <886>-(2)-2718-3666  
Fax : <886>-(2)-2718-8180  
Telex : 23222 HAS-TP  
URL : <http://www.hitachi.com.tw>

Hitachi Asia (Hong Kong) Ltd.  
Group III (Electronic Components)  
7/F., North Tower,  
World Finance Centre,  
Harbour City, Canton Road  
Tsim Sha Tsui, Kowloon,  
Hong Kong  
Tel : <852>-(2)-735-9218  
Fax : <852>-(2)-730-0281  
URL : <http://www.hitachi.com.hk>

Copyright © Hitachi, Ltd., 2000. All rights reserved. Printed in Japan.  
Colophon 2.0