

HA13441, HA13442

Three-Phase Brushless DC Motor Driver

Description

The HA13441 and HA13442 are three-phase brushless DC motor drive ICs of 2 A/phase or 4 A/phase.

Functions

- 2 A/phase (4 A/phase) three phase output circuit
- Hall-effect element amp, matrix
- Chip enable
- Buffer amp
- Control amp
- Speed discriminator
- Oscillation circuit
- Zero-cross detector
- Integrator
- Current limiter
- Ready circuit
- Low supply voltage inhibit
- Over-temperature shut down

Features

- Servo system on a single chip
- Digital servo system requires no adjustment
- Large output current (2 A/phase, 4 A/phase)
- Low output voltage noise
- Small speed error
- Low thermal resistance package

Ordering Information

Type No.	Package
HA13441	SP-23TA
HA13441S	SP-23TD
HA13441V	SP-23TB
HA13442	SP-23TA
HA13442S	SP-23TD
HA13442V	SP-23TB

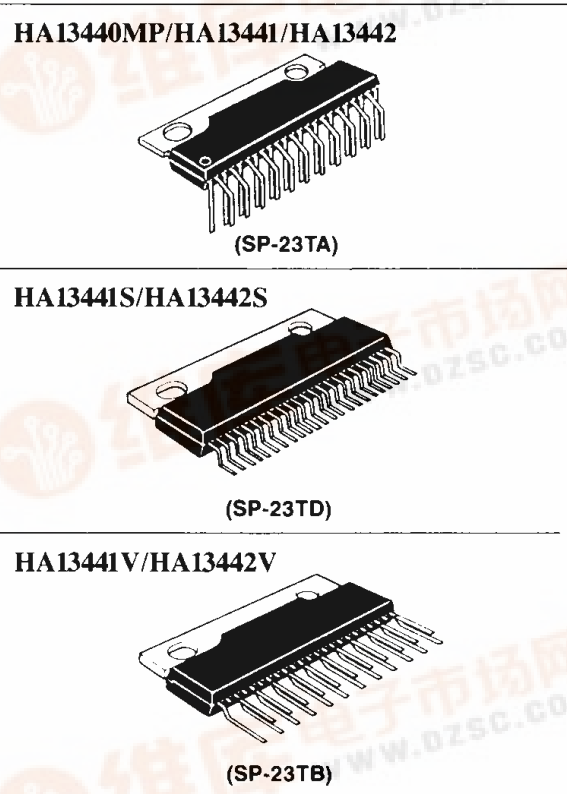

Pin Arrangement

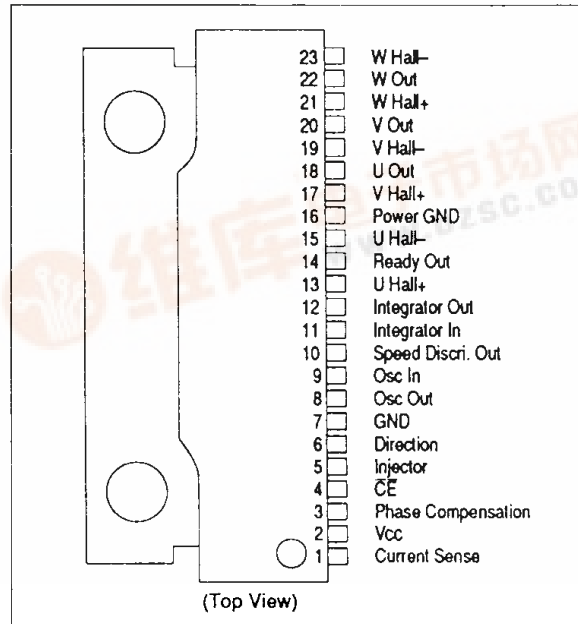

HA13441, HA13442

Block Diagram

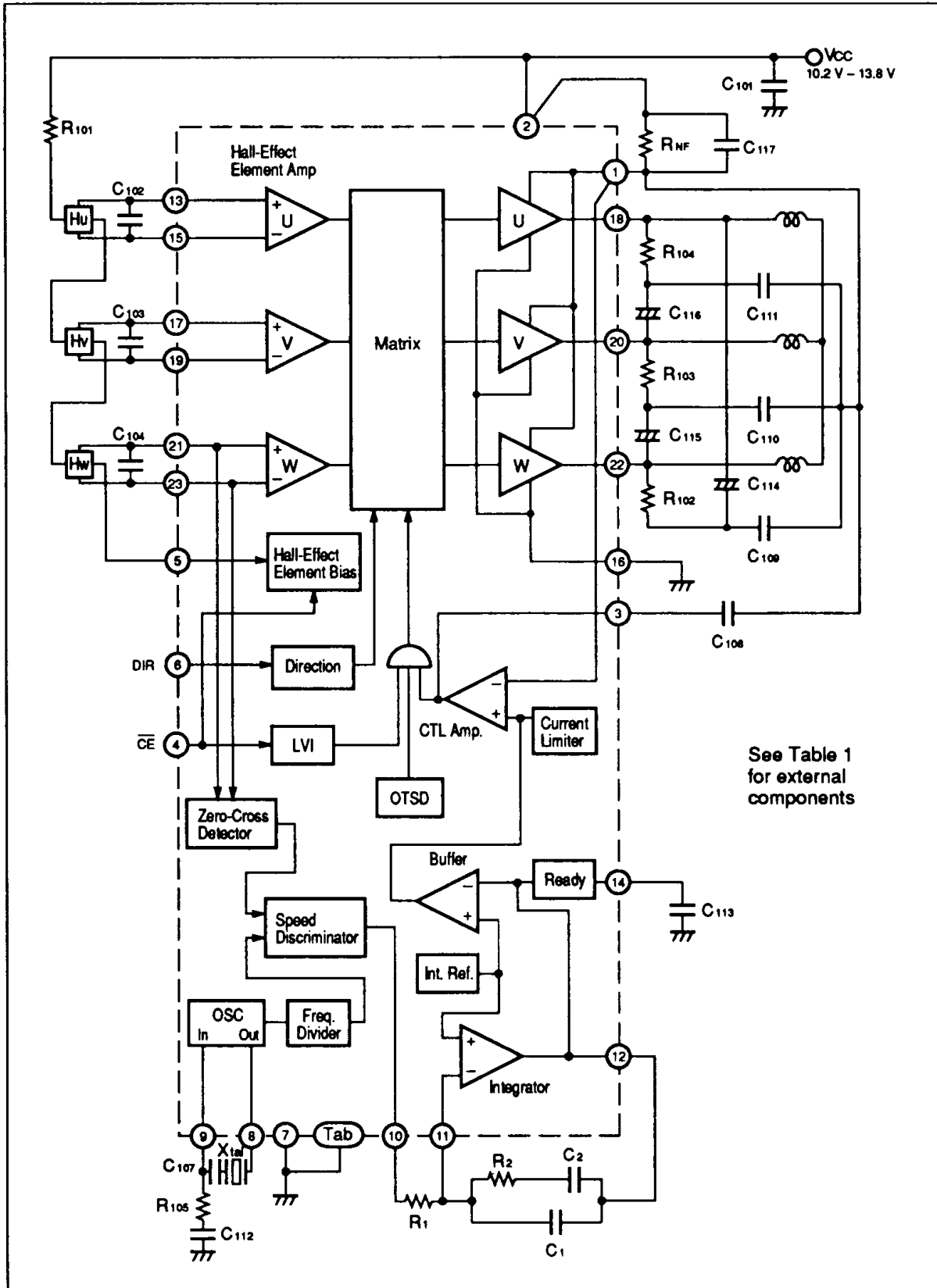

See Table 1
for external
components

Table 1 External Components

Part No.	Reference Value		Purpose	Note
	HA13441 3.5"x2-disk HDD	HA13442 5.25"x6-disk HDD		
R101	1 k Ω	1 k Ω	Hall-effect element bias	
R102	470 Ω	470 Ω	Oscillation stability	1
R103	330 Ω	330 Ω	Stability	2
R104, R105, R106	2.2 Ω	2.2 Ω	Stability	2
R1	22 k Ω	22 k Ω	Integration constant	3
R2	330 k Ω	330 k Ω	Integration constant	3
RNF	0.47 Ω	0.22 Ω	Current sense	4
C101	0.1 μ F	0.1 μ F	Power supply bypass	2
C102	10 pF	10 pF	AC coupling OSC	
C103	0.047 μ F	0.047 μ F	Oscillation stability	1
C104	0.1 μ F	0.1 μ F	Ready output filter	
C105, C106, C107	3300 pF	3300 pF	Stability	2
C108	0.068 μ F	0.068 μ F	Control amp phase compensation	2
C109, C110, C111	0.1 μ F	0.1 μ F	Stability	2, 5
C112, C113, C114	2.2 to 10 μ F	2.2 to 10 μ F	EMI reduction	6
C115	0.1 μ F	0.1 μ F	Stability	5
C1	0.022 μ F	0.1 μ F	Integration constant	3
C2	0.47 μ F	1.0 μ F	Integration constant	3
X'tal	3.932 MHz	3.932 MHz	Resonator	7

- Notes:
1. Unnecessary at some output frequencies. Contact the resonator manufacturer.
 2. Put them as near the IC as possible. When attached at a distance, these parts lose effect.
 3. The optimum value depends on the motor specification (moment of inertia including load, torque constant, standard rotation number).

HA13441, HA13442

4. Output current is limited as shown below. Use non-inductive type for R_{NF} .

$$I_{o\max} = \frac{V_{ref1}}{R_{NF}}$$

5. Use capacitors which have good frequency characteristics and cause no second resonance.
 6. Use non-polar type.
 7. Use crystal oscillator.

Table 2 Truth Table

Chip Enable (CE)	Hall-Effect Amp Input			Output		
	U	V	W	U	V	W
L	H	L	H	H(L)	L(H)	Open(Open)
	H	L	L	H(L)	Open(Open)	L(H)
	H	H	L	Open(Open)	H(L)	L(H)
	L	H	L	L(H)	H(L)	Open(Open)
	L	H	H	L(H)	Open(Open)	H(L)
	L	L	H	Open(Open)	L(H)	H(L)
H	X	X	X	Open		

Open: High Impedance

X: Don't care

Table 3 Absolute Maximum Ratings (Ta=25°C)

Item	Symbol	HA13441	HA13442	Unit	Note
Supply voltage	V _{CC}	+15	+15	V	1
Input voltage	V _{IN}	V _{CC}	V _{CC}	V	2
Output current	I _O	2	4	A	
Power dissipation	P _T	25	25	W	3
Junction temperature	T _J	150	150	°C	4
Storage temperature hange	T _{stg}	-55 to +125	-55 to +125	°C	

The absolute maximum ratings are limiting values, to be applied individually, beyond which the device may be permanently damaged. Functional operation under any of these conditions is not guaranteed. Exposing a circuit to its absolute maximum rating for extended periods of time may affect the device's reliability.

- Notes: 1. The recommended operating supply voltage range is 12 V ± 15% (10.2 V to 13.8 V).
 2. Hall-effect element amp input, Direction input, Chip Enable input.

3. $T_c=75\text{ }^\circ\text{C}$. Thermal resistance is:
 $\theta_{j-c}\leq 3\text{ }^\circ\text{C}$
 $\theta_{j-a}\leq 40\text{ }^\circ\text{C}$
4. The operating junction temperature range is $T_{jop}=0\text{ }^\circ\text{C}$ to $+125\text{ }^\circ\text{C}$.

Table 4 Electrical Characteristics ($T_a=25\text{ }^\circ\text{C}$, $V_{cc}=12\text{ V}$)

Item	Symbol	Min	Typ	Max	Unit	Test Condition	Applicable Terminal	Note	
Quiescent current	I_{CC1}	—	1.0	2	mA	$V_{CE}=2\text{ V}$	1, 2	1	
	I_{CC2}	—	24.0	36.0	mA	$V_{CE}=0.8\text{ V}$		1	
Hall-effect element amp to bias	Input current	I_{HB}	—	2	10	μA	$V_H=6.0\text{ V}$		
	Input common mode voltage range	V_H	1.3	—	9.5	V			
	Bias voltage	V_{HB}	1.3	—	1.8	V	$I_H=5\text{ mA}$	5	
Output amp	Leak current	I_{CER}	—	—	2	mA	$V_{CE}=15\text{ V}$	18, 20, 22	
	Saturation voltage	V_{sat1}	—	2.8	3.2	V	$I_o=3.0\text{ A}(1.5\text{ A})$		2
		V_{sat2}	—	1.8	2.4	V	$I_o=0.6\text{ A}(0.3\text{ A})$		2
Reference voltage internal current limiter	V_{ref1}	0.48	0.56	0.63	V		1	2	
Buffer amp	Internal reference voltage	V_{ref2}	2.95	3.15	3.35	V		11	
	Voltage gain	G_v	-8 (-5)	-6 (-3)	-4 (-1)	dB		1	3
	Difference of gain	ΔG_v	—	—	± 1.0	dB			
Integrator	Input current	$I_B(ER)$	—	—	± 60	nA		11	
	Output voltage swing	A+	1.10	1.40	1.60	V	$I_o=0.5\text{ mA}$	12	
		A-	-0.05	-0.7	-0.85	V	$I_o=-0.5\text{ mA}$		
	Gain bandwidth	BW	100	—	—	kHz	$G=0\text{ dB}$		

HA13441, HA13442

Electrical Characteristics (Ta=25 °C, Vcc=12 V) (cont)

Speed discriminator	Output high voltage	V _{OH}	5.8	6.1	—	V	I _o =0.5 mA	10	4
	Output low voltage	V _{OL}	—	—	0.2	V	I _o =-0.5 mA		4
	Cut off current	I _{off}	—	—	±60	nA			
	Count number		—	2048	—				
Chip enable	Input high voltage	V _{IH}	2.0	—	—	V		4	
	Input low voltage	V _{IL}	—	—	0.8	V			
	Input high current	I _{IH}	—	—	±10	μA	V _{IH} =5.5 V		
	Input low current	I _{IL}	—	—	±10	μA	V _{IL} =0 V		
OSC	Frequency error	f _{osc}	—	—	0.1	%		8	
	Operating frequency	f _{osc}	—	—	8	MHz			
Zero-cross detection sensitivity	V _z	—	—	30	mVpp			21, 23	5
Ready circuit	Output high voltage	V _{OH}	4.8	5.0	—	V	I _{source} =0.1 mA	14	
	Output low voltage	V _{OL}	—	0.2	0.3	V	I _{sink} =0.1 mA		
	Output current	I _{sink}	0.1	0.2	0.3	mA	V=2.5 V		
		I _{fo}	0.1	0.2	0.3	mA	V=2.5 V		
LVI operating voltage		—	—	9.0	V				
OTSD operating temperature	T _{sd}	125	—	—	°C				
Direction	Input high voltage	V _{IH}	4.0	—	—	V		6	
	Input low voltage	V _{IL}	—	—	0.8	V			
	Input high current	I _{IH}	—	—	±10	μA	V _{IH} =5.5 V		
	Input low current	I _{IL}	—	—	±10	μA	V _{IL} =0 V		

- Notes:
1. Sum of ①, ② input pins
 2. Sum of upper and lower transistor saturation voltages.
 3. Measure from V_{cc} pin.
 4. Measure from V_{ref2}.
 5. Minimum input voltage necessary for producing trigger pulse.