



Industrial Digital Bar Code Slot Reader

Technical Data

HBCS-7100 Series

Features

- **Multi Resolution**
Compatible with virtually all bar code resolutions
- **Large Slot Width**
Allows reading thickly laminated cards
- **Sealed Metal Case (IP 66/67)**
Can be installed outdoors or in wet environments
- **Tamper Proof Design**
Ideal for security applications
- **Minimal First Bar Distortion**
- **880 nm Light**
- **Wide Operating Temperature Range**
-40°C to +70°C
- **Wide Scan Speed Range**
- **Black Textured Epoxy Finish**
- **Digital Output**
Open collector output compatible with TTL and CMOS logic
- **Single +5 Volt Supply**

Description

Hewlett-Packard's Industrial Digital Slot Reader is designed to provide excellent scanning performance on a wide variety of bar coded cards and badges. It contains a unique optical/electrical system that integrates over a large vertical area of the bar/space pattern, providing a

greatly improved first read rate even on poorly printed bar codes.

The HBCS-7100 Series uses an infrared (880 nm) light with 0.19 mm (0.0075 in.) resolution.

The extra large depth of field allows the slot reader to have a slot width of 3.2 mm (0.125 in.), thus making it possible to read even thickly laminated cards and badges. When used as a stand alone optics module, the maximum depth of field is dependent upon resolution.

The optics and electronics are housed in a rugged metal case. The case is fully gasketed and sealed, making it suitable for use in outdoor or wet environments. The black epoxy coating adds a durable, finished look to the Digital Slot Reader. When installed using the rear screw holes, the units become tamper proof, making an excellent choice for security access control.

The optical system is centered in the slot track, allowing the user to easily scan from either direction. The wide slot width makes it easy to insert and slide the cards. The optical system is covered with a



recessed window to prevent contamination and reduce the wear on the cards.

The standard slot reader comes with the optics module mounted on a base plate with an opposite rail and 122 cm (48 in.) straight cord. Two standard connectors are available: a male 5 pin, 240°, locking DIN (HBCS-7100); or a female, 9 pin D-sub squeeze to release, (HBCS-7108).

The optics module (HBCS-7150) is available which can be integrated into other equipment or used as a stand alone sensor assembly.

Applications

The digital bar code slot reader is a highly effective alternative to



keyboard data entry. Bar code scanning is faster and more accurate than key entry and provides far greater throughput. In addition, bar code scanning typically has a higher first read rate and greater data accuracy than optical character recognition. When compared to magnetic stripe encoding, bar code offers significant advantages in flexibility of media, symbol placement and immunity to electromagnetic fields.

Hewlett-Packard's Industrial Digital Slot Reader is designed for applications where high first read rate and durability are important factors. The epoxy coated metal case with its tamper proof mounting system, makes these slot readers ideal choices for security access control, time and attendance recording and other bar coded badge and card reading applications.

Electrical Operation

The HBCS-71XX family of digital slot readers consists of a precision optical system, an analog amplifier, a digitizing circuit, and an output transistor. These elements provide a TTL compatible output from a single 4.5 V to 5.5 V DC power supply. The open collector transistor requires a pull-up resistor for proper operation.

A non-reflecting black bar results in a logic high (1) level output, while a reflecting white space will cause a logic low (0) level output. After power up, the slot reader will be fully operational after approximately 6 seconds. During operation, the slot reader will

assume a logic low state after a short period (typically 1 second) if no bar code is scanned. This feature allows multiple scanners (slot readers and wands) to be connected together with a simple OR gate.

The slot reader connector provides a shield which is connected to signal ground. The shield is connected either to the metal housing of the 5 pin DIN connector, or to pin 8 of the 9 pin D-sub connector. A good connection to earth ground is recommended.

The maximum recommended cable length is 7.6 m (25 ft.).

WARNING:

OBSERVING THE INFRARED LIGHT SOURCE IN THE HBCS-7150 AT CLOSE DISTANCES FOR PROLONGED PERIODS OF TIME MAY CAUSE INJURY TO THE EYE. When mounted with the rail in place, the infrared output flux is radiologically safe. With the rail removed, precautions should be taken to avoid prolonged visual observation.

Mounting Considerations Slot Reader

The slot reader (HBCS-7100/7108) is designed to be virtually tamper proof when mounted using the two rear mounting holes. In this case, the cable must be routed from the rear of the slot reader through the mounting surface (wall, door, etc.).

When mounting the slot reader, the cable may be routed through the mounting surface (see above),

or it may be routed along grooves in the base and exit the side of the slot reader at any of four points. This allows flexibility in the mounting orientation.

Optics Module

The optics/electronics module (HBCS-7150) is designed for applications which require a different slot width, integration into a larger housing, or a fixed beam stationary scanner. When using the optics module, the operating distance from the front surface of the module to the symbol will vary depending on the symbol resolution. Figure 1 shows the relationship between operating range and *minimum* symbol resolution for a typical optics module.

This relationship was applied in the design of the slot reader, where a slot width of 3.2 mm (0.125 in.) insures excellent performance reading bar code symbols which have a nominal resolution of 0.19 mm (0.0075 in.) and include normal printing errors.

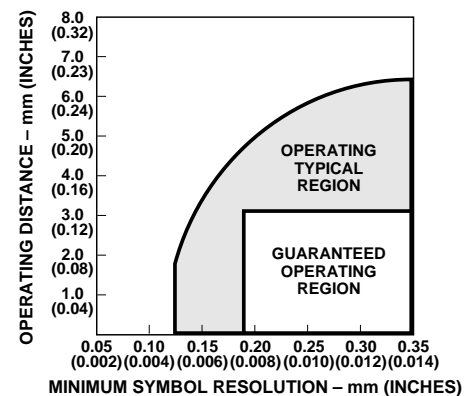

Figure 1.

Recommended Operating Conditions

| Parameter | Symbol | Min. | Max. | Units | Notes |
|------------------------------|------------|---------------|-----------|----------|-------|
| Nominal Narrow Element Width | | 0.19 (0.0075) | | mm (in.) | |
| Scan Velocity | V_{scan} | 20 (8) | 254 (100) | mm (in.) | 1 |
| Contrast | R_W-R_B | 45 | | % | 2 |
| Supply Voltage | V_S | 4.5 | 5.5 | V | 3 |
| Ambient Temperature | T_A | -40 | +70 | °C | 4 |
| Ambient Light | E_V | | 100,000 | lux | 5 |

Absolute Maximum Ratings $T_A = 25^\circ\text{C}$ (unless specified otherwise)

| Parameter | Symbol | Min. | Max. | Units | Notes |
|--------------------------|--------|------|------|-------|-------|
| Storage Temperature | T_S | -40 | +80 | °C | |
| Supply Voltage | V_S | -0.3 | +7.0 | V | |
| Output Transistor Power | P_T | | 200 | mW | |
| Output Collector Voltage | V_O | -0.3 | +20 | V | |

Electrical Characteristics

$T_A = 25^\circ\text{C}$, $V_S = 4.5\text{ V to }5.5\text{ V}$ (unless specified otherwise)

| Parameter | Symbol | Typ. | Max. | Units | Conditions | Notes |
|----------------------------------|----------|------|------|---------------|---|-------|
| Supply Current | I_S | 56 | 100 | mA | $V_S = 5.0\text{ V}$ | |
| High Level Output Current | I_{OH} | | 1.0 | μA | $V_{OH} = 2.4\text{ V}$ | |
| Low Level Output Voltage | V_{OL} | | 0.4 | V | $I_{OL} = 16\text{ mA}$ | |
| Output Rise Time | t_r | 0.9 | 5.0 | μs | 10% - 90% transition $RL = 1\text{ k}\Omega$ | |
| Output Fall Time | t_f | 0.07 | 5.0 | μs | | |
| Electrostatic Discharge Immunity | ESD | 25 | | kV | | 6 |

Notes:

1. Measured scanning a symbol with 0.19 mm narrow elements. For larger narrow element widths, the maximum scan speed will increase proportionally.
2. Contrast is defined as R_W-R_B where R_W is the reflectance of the white spaces and R_B is the reflectance of the black bars, measured at 880 nm.
3. Allowable power supply ripple and noise is frequency dependent. See Figure 5.
4. Non-condensing. If there is frost or dew over the optics window, it should be removed for optimal scanning performance.
5. Direct sunlight at any illumination angle.
6. The shield must be properly terminated (See Figure 2). The human body is modeled by discharging a 300 pF capacitor through a 500 Ω resistor. No damage to the slot reader will occur at the specified level.

Interface Specifications

The slot reader has two different standard connectors: a 5 pin, 240 metal locking DIN; or a 9 pin female D-sub squeeze to release. The recommended interface is shown in Figure 2. The mechanical specifications for the 5 pin DIN are shown in Figure 3. The mechanical specifications for the 9 pin D-sub are shown in Figure 4.

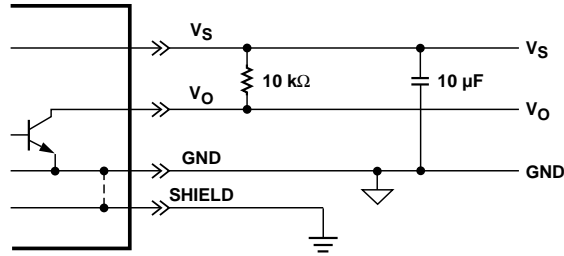

Figure 2. Recommended Interface.

Pinout

| Function | 5 pin DIN | 9 pin D-sub |
|----------------|-----------|-------------|
| V _S | 1 | 9 |
| Output | 2 | 2 |
| Ground | 4 | 7 |
| Shield | Case | 8 |
| No Connect | 3,5 | 1,3,4,5,6 |

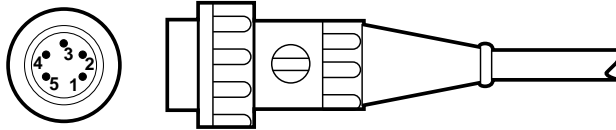

Figure 3. Connector Configuration for HBCS-71X0.

Shield and ground are tied together in the connector.

Note: If the part is purchased with stripped and tinned wires, or if the connector is removed, the ground and shield wires must be connected together for proper operation.

Wire Color

| Function | Color |
|----------------|--------------|
| V _S | Red |
| Output | Yellow/White |
| Ground | Black |
| Shield | Braid |

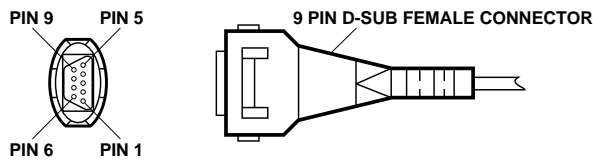

Figure 4. Connector Configuration for HBCS-71X8.

PSRR Performance

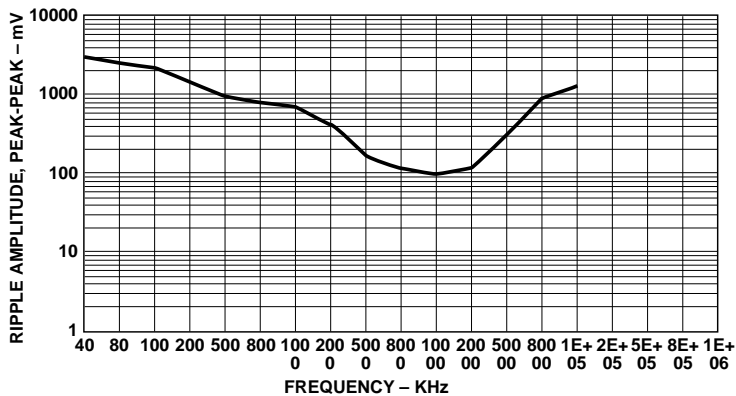
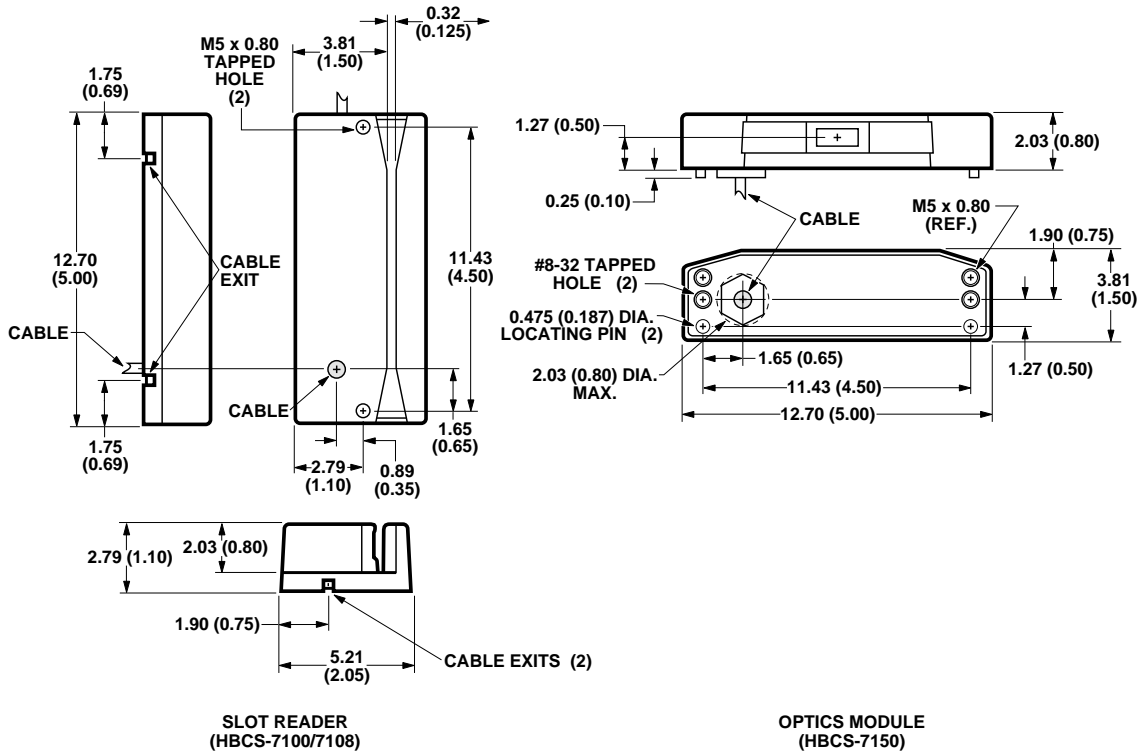

Figure 5. Ripple Noise Needed to Switch Output.



The CE Mark demonstrates compliance with EC directives on EMC.

Dimensions



Notes:

7. Mounting holes on the HBCS-7100/7108 are suitable for either #10-32 or M5-0.80 screws.
8. Mounting holes on the HBCS-7150 are for #8-32 screws.
9. Slot readers and optics modules have a black textured epoxy finish.
10. All dimensions are nominal and are stated in millimeters and (inches).

Selection Guide

| | HBCS-7100 | HBCS-7150 |
|----------------------------------|---|------------------|
| 5 pin DIN Connector | Standard | Standard |
| 9 pin D-Sub Connector | HBCS-7108 | NA |
| No Connector Strip and Tin Leads | HBCS-7104* | HBCS-7154* |
| Individually Boxed Slot Reader | Order Option #A01 with the above referenced part-number. The slot reader is shipped in a "kraft" box, including an HBCS-7100 series data sheet. | |

*Build to order product only. Minimum stock available for engineering evaluation purchases.

Symbol Placement

The center of the slot reader's optical system is located 12.7 mm (0.50 in.) from the bottom of the slot. Consequently, bar code symbols to be read by the slot reader must be positioned on the card(s) or document(s) at a height which insures that all bars and spaces will cross a line located 12.7 mm from the bottom edge of the card(s) or document(s). For optimal performance, all bars and spaces should cross the area between 1.14 mm (0.45 in.) and 1.40 mm (0.55 in.) from the bottom edge.

The bars and spaces should be perpendicular to the bottom edge, however, a skew of ± 4 degrees from the perpendicular is acceptable.

Maintenance Considerations

The slot reader and optics module include a window which is slightly recessed in order to prevent direct contact with the bar code symbol. This reduces the wear on both the window and the symbol. The window may become dirty over a period of time. If this occurs, clean the window with a commercial glass cleaner.

Testing

All Hewlett-Packard slot readers are 100% tested for performance and digitizing accuracy after manufacture. This insures a consistent quality product. More information about Hewlett-Packard's test procedures, test set up, and test limits are available on request.

Optional Features

For options such as special cables or connectors, contact your nearest Hewlett-Packard sales office or authorized representative.

Warranty and Service

Hewlett Packard Slot Readers are warranted for a period of one year after purchase covering defects in material and workmanship. Hewlett-Packard will repair or, at its option, replace products that prove to be defective in material or workmanship under proper use during the warranty period.

NO OTHER WARRANTIES ARE EXPRESSED OR IMPLIED, INCLUDING BUT NOT LIMITED TO THE IMPLIED WARRANTIES OF MERCHANTABILITY AND FITNESS FOR A PARTICULAR PURPOSE. HEWLETT-PACKARD IS NOT LIABLE FOR CONSEQUENTIAL DAMAGES.

For additional warranty or service information, please contact your local Hewlett-Packard sales representative or authorized distributor.