

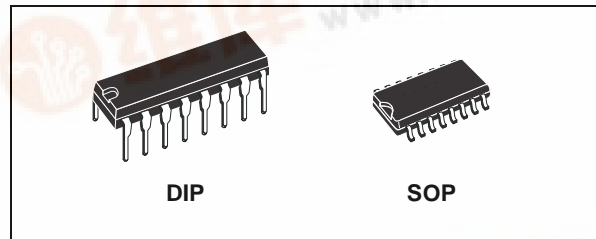

HCF4015B

DUAL 4-STAGE STATIC SHIFT REGISTER WITH SERIAL INPUT/PARALLEL OUTPUT

- MEDIUM SPEED OPERATION 12 MHz (Typ.)
CLOCK RATE AT $V_{DD} - V_{SS} = 10V$
- FULLY STATIC OPERATION
- 8 MASTER-SLAVE FLIP-FLOPS PLUS
INPUT AND OUTPUT BUFFERING
- HIGH NOISE IMMUNITY
- QUIESCENT CURRENT SPECIFIED UP TO
20V
- 5V, 10V AND 15V PARAMETRIC RATINGS
- INPUT LEAKAGE CURRENT
 $I_l = 100nA$ (MAX) AT $V_{DD} = 18V$ $T_A = 25^\circ C$
- 100% TESTED FOR QUIESCENT CURRENT
- MEETS ALL REQUIREMENTS OF JEDEC
JESD13B "STANDARD SPECIFICATIONS
FOR DESCRIPTION OF B SERIES CMOS
DEVICES"



ORDER CODES

PACKAGE	TUBE	T & R
DIP	HCF4015BEY	
SOP	HCF4015BM1	HCF4015M013TR

DESCRIPTION

HCF4015B is a monolithic integrated circuit fabricated in Metal Oxide Semiconductor technology available in DIP and SOP packages. HCF4015B consists of two identical, independent, 4 stage serial-input/parallel-output registers. Each register has independent CLOCK and RESET inputs as well as a single serial DATA input. "Q" outputs are available from each of the

four stages on both registers. All register stages are D-TYPE, MASTER-SLAVE flip-flops. The logic level present at the DATA input is transferred into the first register stage and shifted over one stage at each positive going clock transition. The resetting of all stages is accomplished by a high level on the reset line. It is possible to expand the register to 8 stages using one HCF4015B package and to expand to more than 8 stages by using addition HCF4015Bs.

PIN CONNECTION

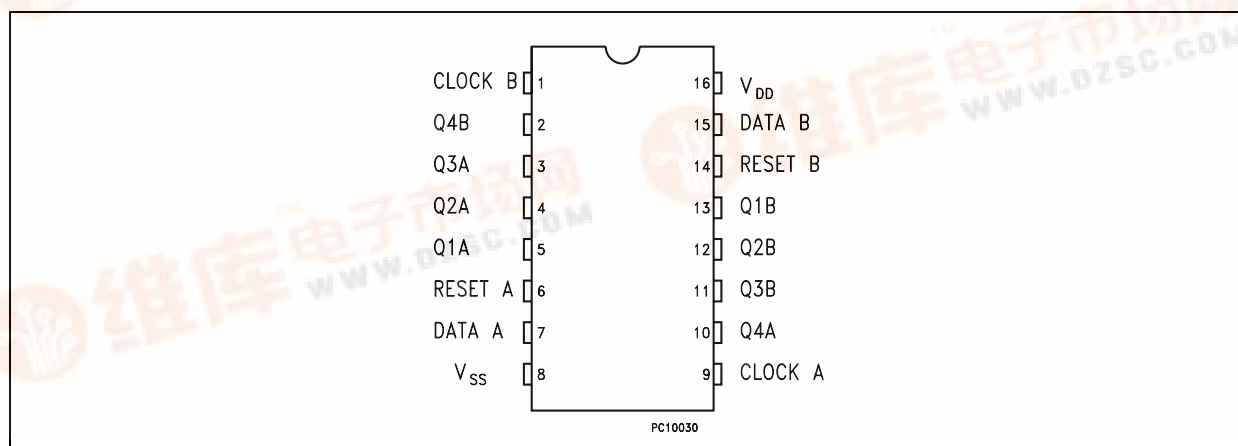

HCF4015B

INPUT EQUIVALENT CIRCUIT

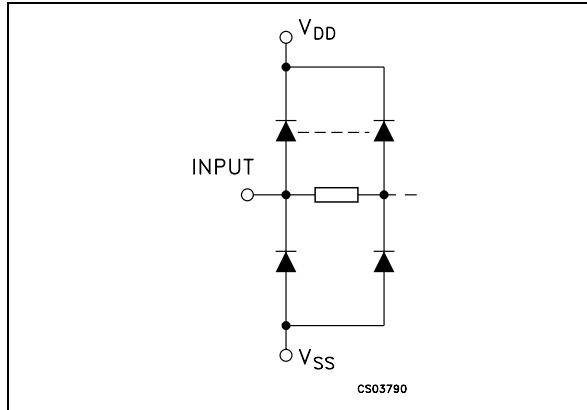

PIN DESCRIPTION

PIN No	SYMBOL	NAME AND FUNCTION
1, 9	CLOCK A CLOCK B	Clock Input
6, 14	RESET A RESET B	Reset Input
7, 15	DATA A DATA B	Data Inputs
5, 4, 3, 10	Q _n A	Outputs A-Stage
13, 12, 11, 2	Q _n B	Outputs B-Stage
8	V _{SS}	Negative Supply Voltage
16	V _{DD}	Positive Supply Voltage

FUNCTIONAL DIAGRAM

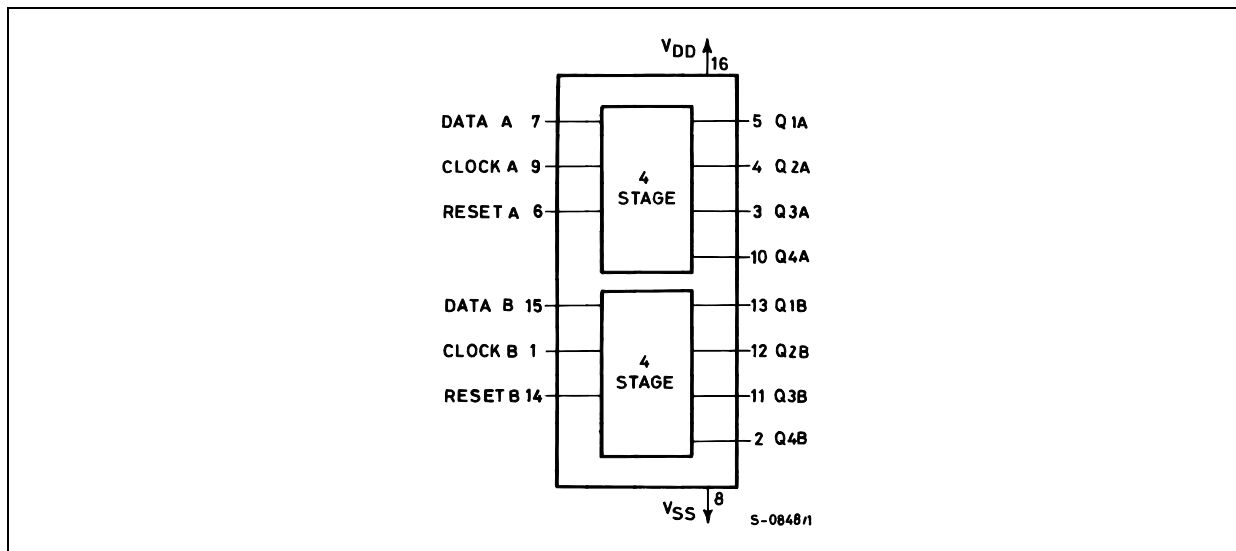

TRUTH TABLE

CLOCK	D	R	Q ₁	Q _n
	L	L	L	Q _n - 1
	H	L	H	Q _n - 1
	X	L	Q ₁	Q _n - (NO CHANGE)
X	X	H	L	0

X : Don't Care

LOGIC DIAGRAM

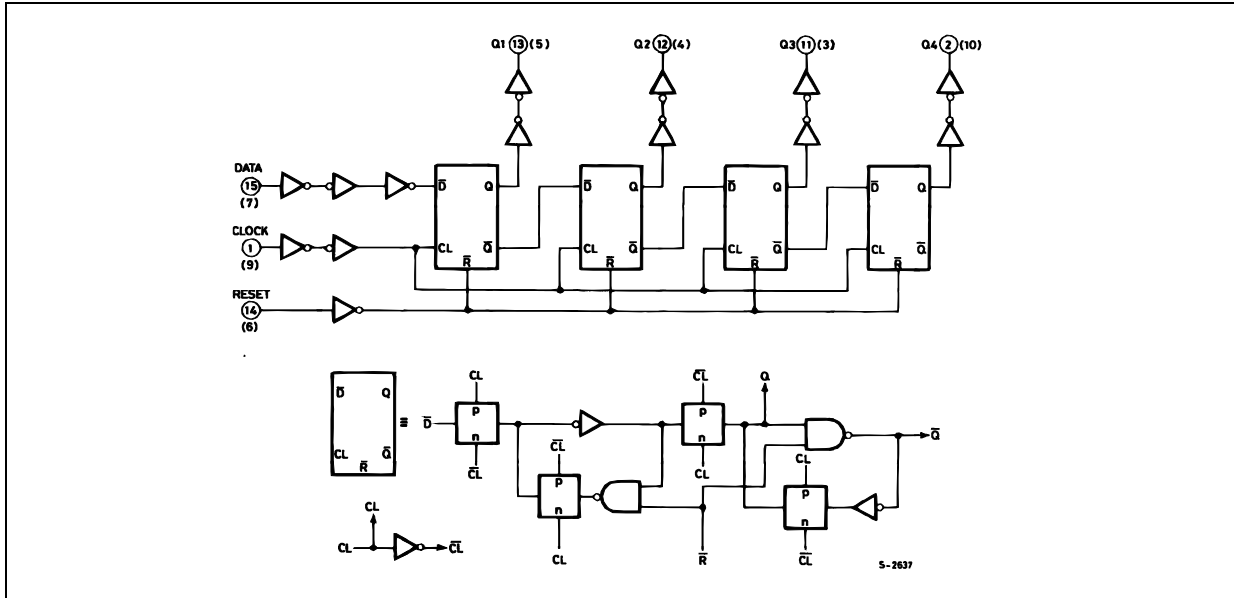

ABSOLUTE MAXIMUM RATINGS

Symbol	Parameter	Value	Unit
V_{DD}	Supply Voltage	-0.5 to +22	V
V_I	DC Input Voltage	-0.5 to $V_{DD} + 0.5$	V
I_I	DC Input Current	± 10	mA
P_D	Power Dissipation per Package	200	mW
	Power Dissipation per Output Transistor	100	mW
T_{op}	Operating Temperature	-55 to +125	$^{\circ}C$
T_{stg}	Storage Temperature	-65 to +150	$^{\circ}C$

Absolute Maximum Ratings are those values beyond which damage to the device may occur. Functional operation under these conditions is not implied. All voltage values are referred to V_{SS} pin voltage.

RECOMMENDED OPERATING CONDITIONS

Symbol	Parameter	Value	Unit
V_{DD}	Supply Voltage	3 to 20	V
V_I	Input Voltage	0 to V_{DD}	V
T_{op}	Operating Temperature	-55 to 125	$^{\circ}C$

HCF4015B

DC SPECIFICATIONS

Symbol	Parameter	Test Condition				Value						Unit	
		V _I (V)	V _O (V)	I _{OL} (μ A)	V _{DD} (V)	T _A = 25°C			-40 to 85°C		-55 to 125°C		
						Min.	Typ.	Max.	Min.	Max.	Min.		Max.
I _L	Quiescent Current	0/5			5		0.04	5		150		150	μ A
		0/10			10		0.04	10		300		300	
		0/15			15		0.04	20		600		600	
		0/20			20		0.08	100		3000		3000	
V _{OH}	High Level Output Voltage	0/5		<1	5	4.95			4.95		4.95		V
		0/10		<1	10	9.95			9.95		9.95		
		0/15		<1	15	14.95			14.95		14.95		
V _{OL}	Low Level Output Voltage	5/0		<1	5		0.05			0.05		0.05	V
		10/0		<1	10		0.05			0.05		0.05	
		15/0		<1	15		0.05			0.05		0.05	
V _{IH}	High Level Input Voltage		0.5/4.5	<1	5	3.5			3.5		3.5		V
			1/9	<1	10	7			7		7		
			1.5/13.5	<1	15	11			11		11		
V _{IL}	Low Level Input Voltage		4.5/0.5	<1	5			1.5		1.5		1.5	V
			9/1	<1	10			3		3		3	
			13.5/1.5	<1	15			4		4		4	
I _{OH}	Output Drive Current	0/5	2.5	<1	5	-1.36	-3.2		-1.1		-1.1		mA
		0/5	4.6	<1	5	-0.44	-1		-0.36		-0.36		
		0/10	9.5	<1	10	-1.1	-2.6		-0.9		-0.9		
		0/15	13.5	<1	15	-3.0	-6.8		-2.4		-2.4		
I _{OL}	Output Sink Current	0/5	0.4	<1	5	0.44	1		0.36		0.36		mA
		0/10	0.5	<1	10	1.1	2.6		0.9		0.9		
		0/15	1.5	<1	15	3.0	6.8		2.4		2.4		
I _I	Input Leakage Current	0/18	Any Input		18		$\pm 10^{-5}$	± 0.1		± 1		± 1	μ A
C _I	Input Capacitance		Any Input				5	7.5					pF

The Noise Margin for both "1" and "0" level is: 1V min. with V_{DD}=5V, 2V min. with V_{DD}=10V, 2.5V min. with V_{DD}=15V

DYNAMIC ELECTRICAL CHARACTERISTICS ($T_{amb} = 25^{\circ}\text{C}$, $C_L = 50\text{pF}$, $R_L = 200\text{K}\Omega$, $t_r = t_f = 20\text{ ns}$)

Symbol	Parameter	Test Condition		Value (*)			Unit
		V_{DD} (V)		Min.	Typ.	Max.	
CLOCKED OPERATION							
t_{PLH} t_{PHL}	Propagation Delay Time (carry out or decoded out lines)	5			160	320	ns
		10			80	160	
		15			60	120	
t_{THL} t_{TLH}	Transition Time (carry out or decoded out lines)	5			100	200	ns
		10			50	100	
		15			40	80	
f_{CL}	Maximum Clock Input Frequency	5		3	6		MHz
		10		6	12		
		15		8.5	17		
t_W	Clock Pulse Width	5		180	90		ns
		10		80	40		
		15		50	25		
t_r, t_f (1)	Clock Input Rise or Fall Time	5				15	μs
		10				15	
		15				15	
t_{setup}	Data Setup Time	5		70	35		ns
		10		40	20		
		15		30	15		
RESET OPERATION							
t_{PLH}, t_{PHL}	Propagation Delay Time	5			200	400	ns
		10			100	200	
		15			80	160	
t_W	Reset Pulse Width	5		200	100		ns
		10		80	40		
		15		60	30		

(*) Typical temperature coefficient for all V_{DD} value is 0.3 %/°C.

(1) If more than one unit is cascaded in the parallel clocked application, t_{CL} should be made less than or equal to the sum of the fixed propagation delay at 15 pF and the transmission time of the carry output driving stage of the estimated capacitive load.

HCF4015B

TEST CIRCUIT

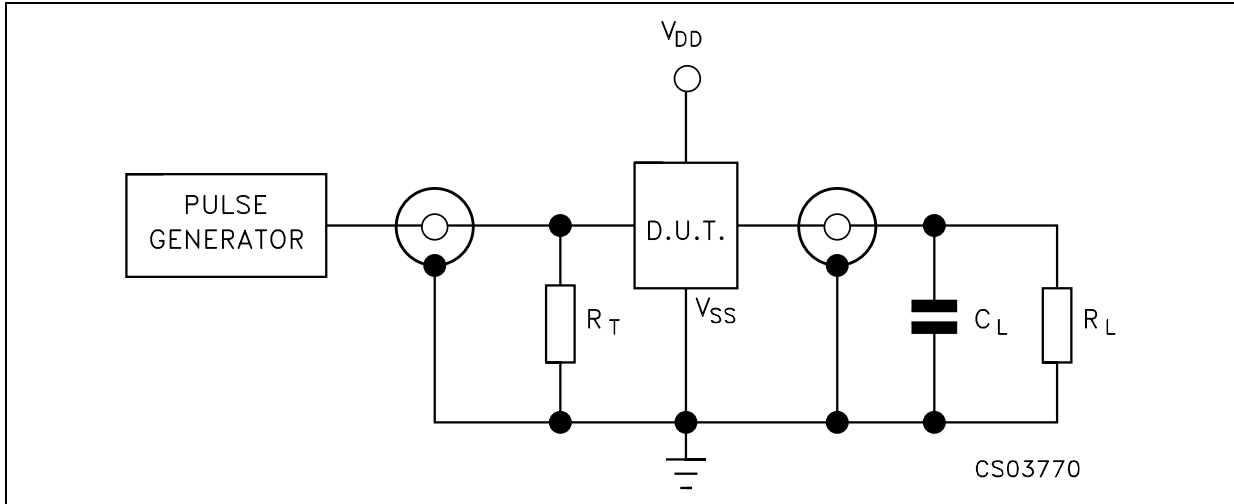

$C_L = 50\text{pF}$ or equivalent (includes jig and probe capacitance)
 $R_L = 200\text{K}\Omega$
 $R_T = Z_{OUT}$ of pulse generator (typically 50Ω)

WAVEFORM 1 : MINIMUM PULSE WIDTH, PROPAGATION DELAY TIME ($f=1\text{MHz}$; 50% duty cycle)

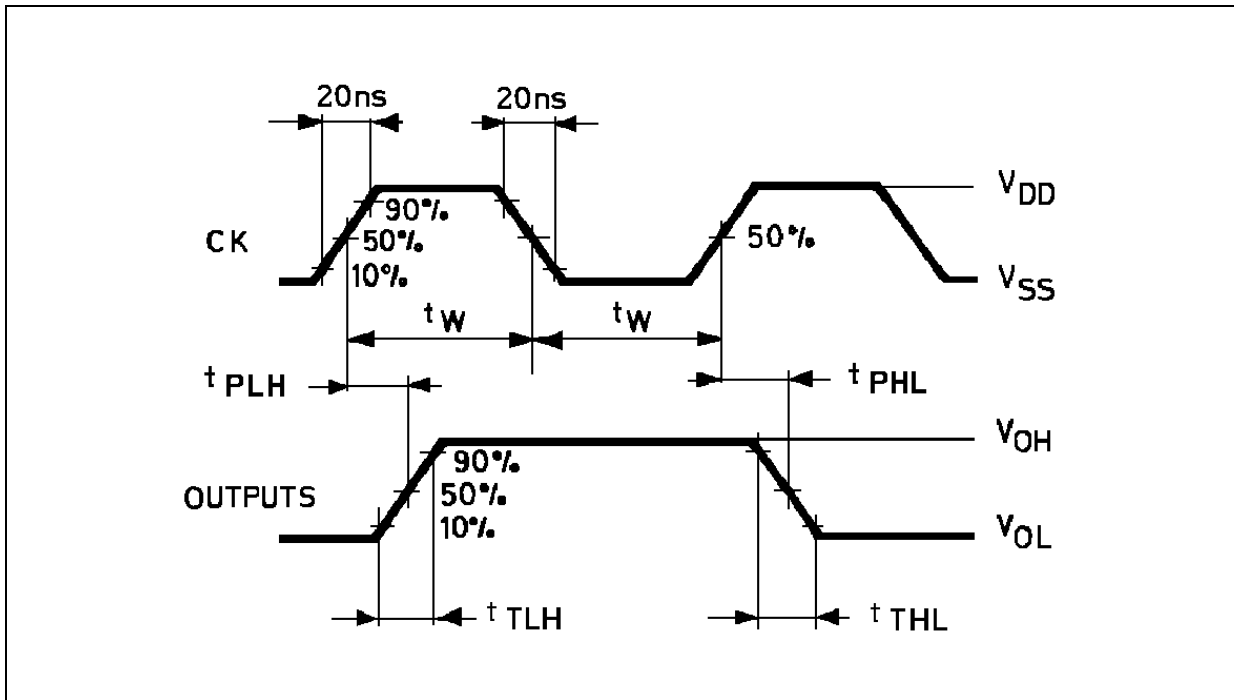

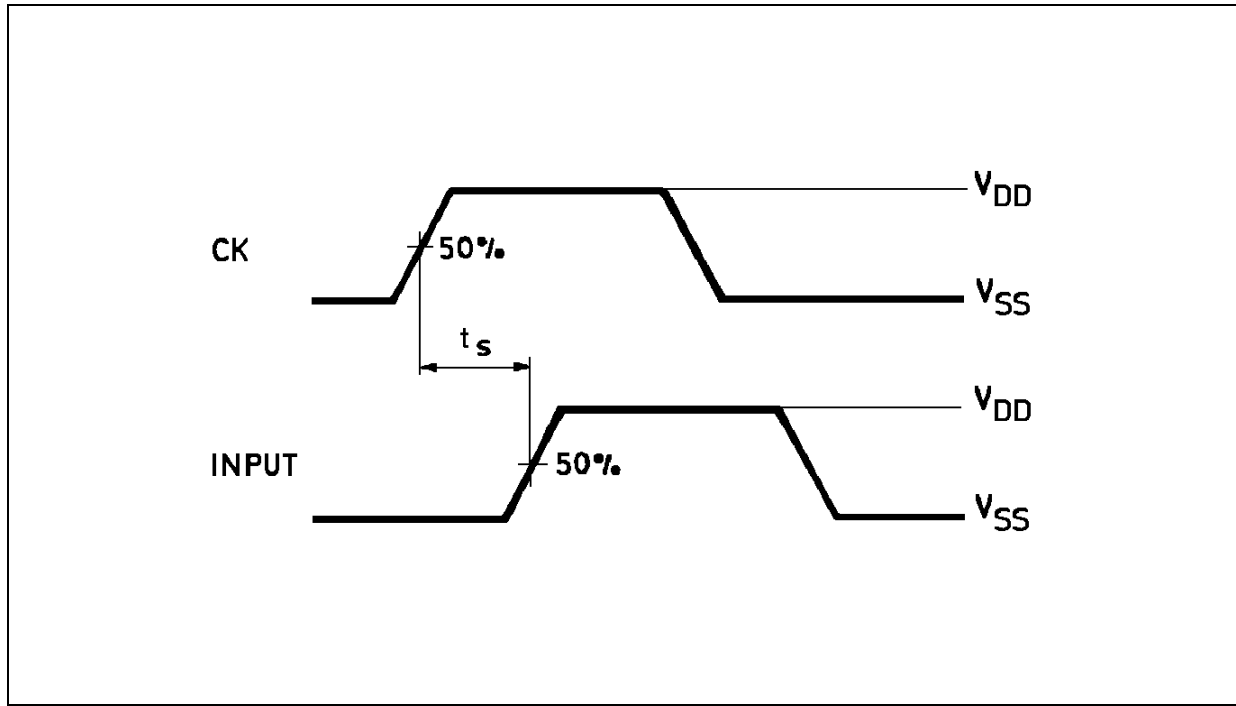
WAVEFORM 2 : MINIMUM SETUP TIME ($f=1\text{MHz}$; 50% duty cycle)

Plastic DIP-16 (0.25) MECHANICAL DATA

DIM.	mm.			inch		
	MIN.	TYP.	MAX.	MIN.	TYP.	MAX.
a1	0.51			0.020		
B	0.77		1.65	0.030		0.065
b		0.5			0.020	
b1		0.25			0.010	
D			20			0.787
E		8.5			0.335	
e		2.54			0.100	
e3		17.78			0.700	
F			7.1			0.280
l			5.1			0.201
L		3.3			0.130	
Z			1.27			0.050

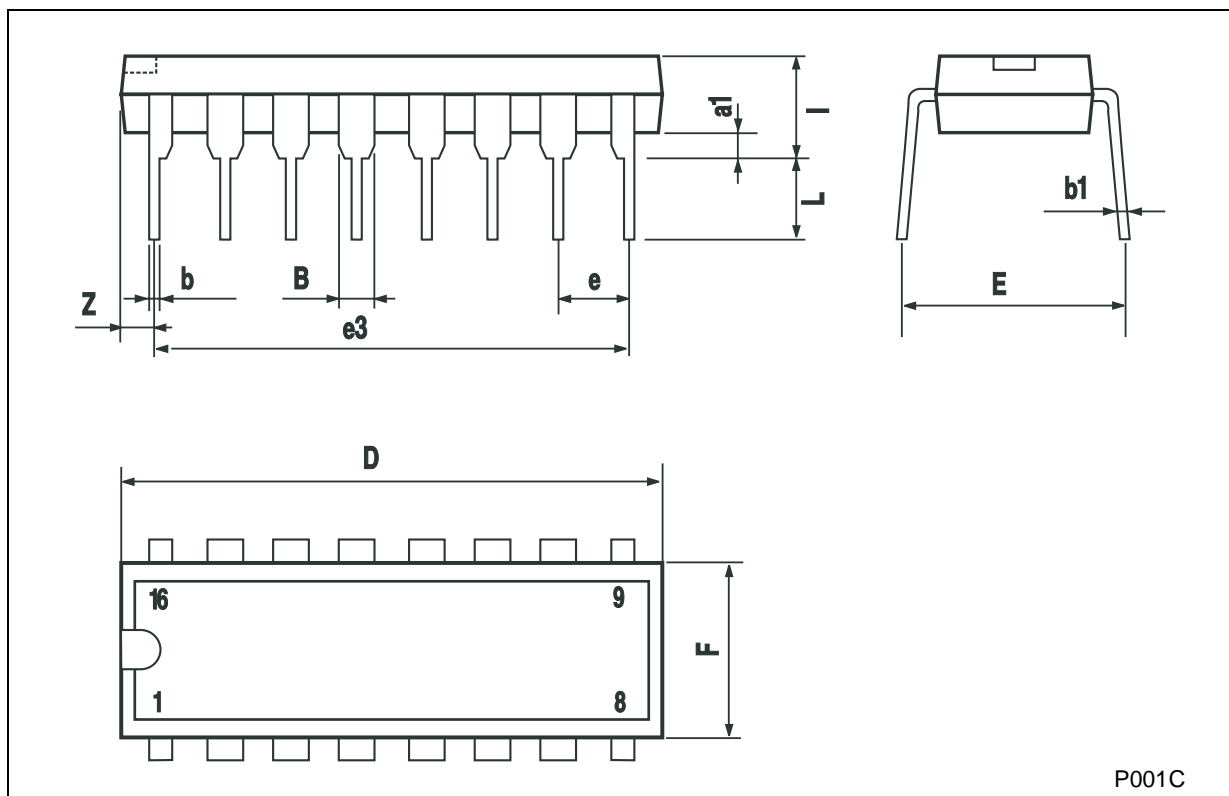

SO-16 MECHANICAL DATA

DIM.	mm.			inch		
	MIN.	TYP	MAX.	MIN.	TYP.	MAX.
A			1.75			0.068
a1	0.1		0.2	0.003		0.007
a2			1.65			0.064
b	0.35		0.46	0.013		0.018
b1	0.19		0.25	0.007		0.010
C		0.5			0.019	
c1	45° (typ.)					
D	9.8		10	0.385		0.393
E	5.8		6.2	0.228		0.244
e		1.27			0.050	
e3		8.89			0.350	
F	3.8		4.0	0.149		0.157
G	4.6		5.3	0.181		0.208
L	0.5		1.27	0.019		0.050
M			0.62			0.024
S	8° (max.)					

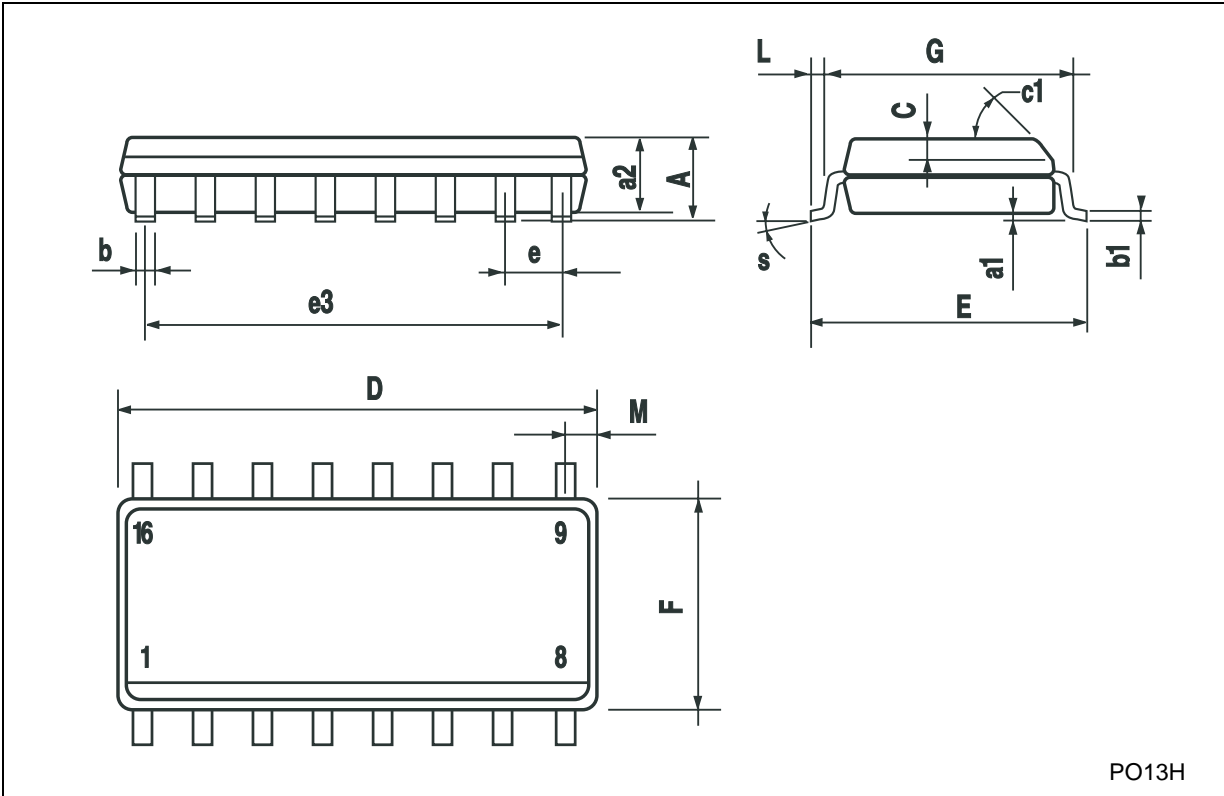

PO13H

Information furnished is believed to be accurate and reliable. However, STMicroelectronics assumes no responsibility for the consequences of use of such information nor for any infringement of patents or other rights of third parties which may result from its use. No license is granted by implication or otherwise under any patent or patent rights of STMicroelectronics. Specifications mentioned in this publication are subject to change without notice. This publication supersedes and replaces all information previously supplied. STMicroelectronics products are not authorized for use as critical components in life support devices or systems without express written approval of STMicroelectronics.

© The ST logo is a registered trademark of STMicroelectronics

© 2002 STMicroelectronics - Printed in Italy - All Rights Reserved
STMicroelectronics GROUP OF COMPANIES

Australia - Brazil - Canada - China - Finland - France - Germany - Hong Kong - India - Israel - Italy - Japan - Malaysia - Malta - Morocco
Singapore - Spain - Sweden - Switzerland - United Kingdom - United States.

© <http://www.st.com>