



40 ns Prop. Delay, SO-8 Optocoupler

Technical Data

HCPL-0710

Features

- +5 V CMOS Compatibility
- 8 ns max. Pulse Width Distortion
- 20 ns max. Prop. Delay Skew
- High Speed: 12 Mbd
- 40 ns max. Prop. Delay
- 10 kV/μs Minimum Common Mode Rejection
- 0°C to 85°C Temp. Range
- Safety and Regulatory Approvals

Approvals

UL Recognized
2500 V rms for 1 min. per
UL 1577
CSA Component Acceptance
Notice #5

Applications

- Digital Fieldbus Isolation: DeviceNet, SDS, Profibus
- AC Plasma Display Panel Level Shifting
- Multiplexed Data Transmission
- Computer Peripheral Interface
- Microprocessor System Interface

Description

Available in the SO-8 package style, the HCPL-0710 optocoupler utilizes the latest CMOS IC technology to achieve outstanding performance with very low power consumption. The HCPL-0710 requires only two bypass capacitors for complete CMOS compatibility.

Basic building blocks of the HCPL-0710 are a CMOS LED driver IC, a high speed LED and a CMOS detector IC. A CMOS logic input signal controls the LED driver IC which supplies current to the LED. The detector IC incorporates an integrated photodiode, a high-speed transimpedance amplifier, and a voltage comparator with an output driver.

Functional Diagram

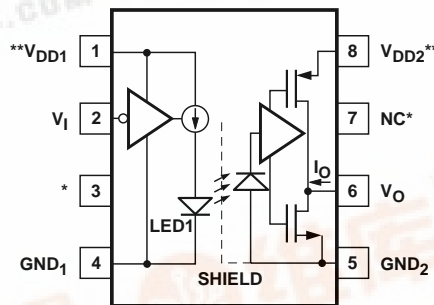

TRUTH TABLE
(POSITIVE LOGIC)

V _I , INPUT	LED1	V _O , OUTPUT
H	OFF	H
L	ON	L

*Pin 3 is the anode of the internal LED and must be left unconnected for guaranteed data sheet performance. Pin 7 is not connected internally. External connections to pin 7 are not recommended.

**A 0.1 μF bypass capacitor must be connected between pins 1 and 4, and 5 and 8.

CAUTION: It is advised that normal static precautions be taken in handling and assembly of this component to prevent damage and/or degradation which may be induced by ESD.



Ordering Information

Specify Part Number followed by Option Number (if desired)

Example

HCPL-0710#XXX

- No Option = Standard SO-8 package, 100 per tube.
- 500 = Tape and Reel Packaging Option, 1500 per reel.

Option data sheets available. Contact Hewlett-Packard sales representative or authorized distributor.

Package Outline Drawing

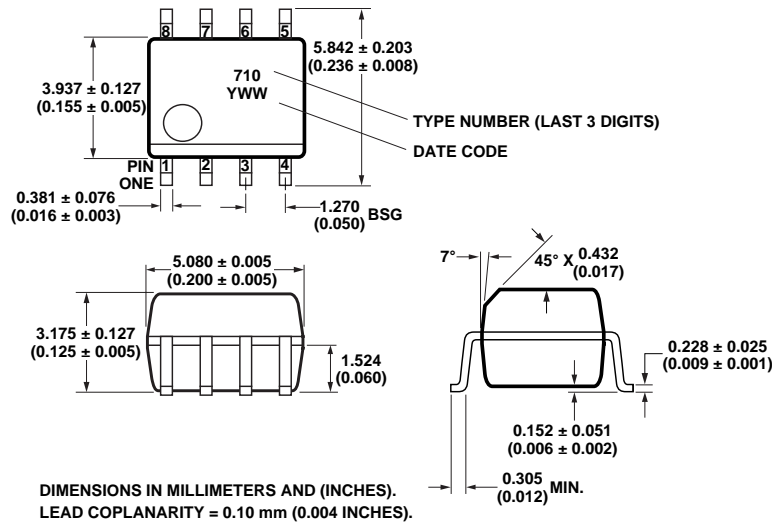

Solder Reflow Thermal Profile

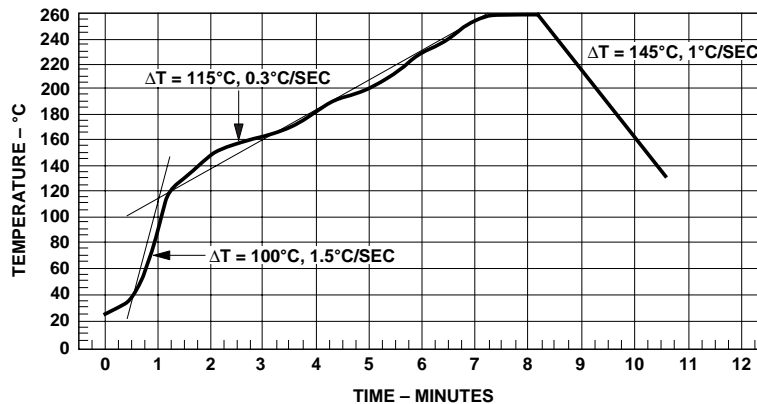

(NOTE: USE OF NON-CHLORINE ACTIVATED FLUXES IS RECOMMENDED.)

Regulatory Information

The HCPL-0710 has been approved by the following organizations:

UL

Recognized under UL 1577, component recognition program, File E55361.

CSA

Approved under CSA Component Acceptance Notice #5, File CA 88324.

Insulation and Safety Related Specifications

Parameter	Symbol	Value	Units	Conditions
Minimum External Air Gap (Clearance)	L(I01)	4.9	mm	Measured from input terminals to output terminals, shortest distance through air.
Minimum External Tracking (Creepage)	L(I02)	4.8	mm	Measured from input terminals to output terminals, shortest distance path along body.
Minimum Internal Plastic Gap (Internal Clearance)		0.08	mm	Insulation thickness between emitter and detector; also known as distance through insulation.
Tracking Resistance (Comparative Tracking Index)	CTI	200	Volts	DIN IEC 112/VDE 0303 Part 1
Isolation Group		IIIa		Material Group (DIN VDE 0110, 1/89, Table 1)

Absolute Maximum Ratings

Parameter	Symbol	Min.	Max.	Units	Figure
Storage Temperature	T_S	-55	125	°C	
Ambient Operating Temperature ^[1]	T_A	-40	+100	°C	
Supply Voltages	V_{DD1}, V_{DD2}	0	5.5	Volts	
Input Voltage	V_I	-0.5	$V_{DD1} + 0.5$	Volts	
Output Voltage	V_O	-0.5	$V_{DD2} + 0.5$	Volts	
Average Output Current	I_O		10	mA	
Lead Solder Temperature	260°C for 10 sec., 1.6 mm below seating plane				
Solder Reflow Temperature Profile	See Solder Reflow Temperature Profile Section				

Recommended Operating Conditions

Parameter	Symbol	Min.	Max.	Units	Figure
Ambient Operating Temperature	T_A	0	+85	°C	
Supply Voltages	V_{DD1}, V_{DD2}	4.5	5.5	V	
Logic High Input Voltage	V_{IH}	$0.8 * V_{DD1}$	V_{DD1}	V	1, 2
Logic Low Input Voltage	V_{IL}	0.0	0.8	V	
Input Signal Rise and Fall Times	t_r, t_f		1.0	ms	

Electrical Specifications

Test conditions that are not specified can be anywhere within the recommended operating range. All typical specifications are at $T_A = +25^\circ\text{C}$, $V_{DD1} = V_{DD2} = +5\text{ V}$.

Parameter	Symbol	Min.	Typ.	Max.	Units	Test Conditions	Fig.	Note
DC Specifications								
Logic Low Input Supply Current	I_{DD1L}		6.0	10.0	mA	$V_I = 0\text{ V}$		2
Logic High Input Supply Current	I_{DD1H}		1.5	3.0	mA	$V_I = V_{DD1}$		
Input Supply Current	I_{DD1}			13.0	mA			
Output Supply Current	I_{DD2}		5.5	11.0	mA			
Input Current	I_I	-10		10	μA			
Logic High Output Voltage	V_{OH}	$V_{DD2} - 0.1$	V_{DD2}		V	$I_O = -20\ \mu\text{A}$, $V_I = V_{IH}$	1, 2	
		$0.8 * V_{DD2}$	$V_{DD2} - 0.5$			$I_O = -4\ \text{mA}$, $V_I = V_{IH}$		
Logic Low Output Voltage	V_{OL}		0	0.1	V	$I_O = 20\ \mu\text{A}$, $V_I = V_{IL}$		
			0.5	1.0		$I_O = 4\ \text{mA}$, $V_I = V_{IL}$		
Switching Specifications								
Propagation Delay Time to Logic Low Output	t_{PHL}		20	40	ns	$C_L = 15\ \text{pF}$ CMOS Signal Levels	3, 7	3
Propagation Delay Time to Logic High Output	t_{PLH}		23	40				
Pulse Width	PW	80						
Data Rate				12.5	MBd			4
Pulse Width Distortion $ t_{PHL} - t_{PLH} $	PWD		3	8	ns	$C_L = 15\ \text{pF}$ CMOS Signal Levels	4, 8	5
Propagation Delay Skew	t_{PSK}			20				
Output Rise Time (10 - 90%)	t_R		9					
Output Fall Time (90 - 10%)	t_F		8					
Common Mode Transient Immunity at Logic High Output	$ CM_H $	10	20					
Common Mode Transient Immunity at Logic Low Output	$ CM_L $	10	20		kV/ μs	$V_I = V_{DD1}$, $V_O > 0.8 V_{DD1}$, $V_{CM} = 1000\ \text{V}$		7
Input Dynamic Power Dissipation Capacitance	C_{PD1}		60		pF			8
Output Dynamic Power Dissipation Capacitance	C_{PD2}		10					

Package Characteristics

Parameter	Symbol	Min.	Typ.	Max.	Units	Test Conditions	Fig.	Note
Input-Output Momentary Withstand Voltage	V_{ISO}	2500			Vrms	$RH \leq 50\%$, $t = 1 \text{ min.}$, $T_A = 25^\circ\text{C}$		9, 10, 11
Resistance (Input-Output)	R_{I-O}		10^{12}		Ω	$V_{I-O} = 500 \text{ Vdc}$		9
Capacitance (Input-Output)	C_{I-O}		0.6		pF	$f = 1 \text{ MHz}$		
Input Capacitance	C_I		3.0					12
Input IC Junction-to-Case Thermal Resistance	θ_{jci}		160		$^\circ\text{C/W}$	Thermocouple located at center underside of package		
Output IC Junction-to-Case Thermal Resistance	θ_{jco}		135					
Package Power Dissipation	P_{PD}			150	mW			

Notes:

- Absolute Maximum ambient operating temperature means the device will not be damaged if operated under these conditions. It does not guarantee functionality.
- The LED is ON when V_I is low and OFF when V_I is high.
- t_{PHL} propagation delay is measured from the 50% level on the falling edge of the V_I signal to the 50% level of the falling edge of the V_O signal. t_{PLH} propagation delay is measured from the 50% level on the rising edge of the V_I signal to the 50% level of the rising edge of the V_O signal.
- Minimum Pulse Width is the shortest pulse width at which 10% maximum, Pulse Width Distortion can be guaranteed. Maximum Data Rate is the inverse of Minimum Pulse Width. Operating the HCPL-0710 at data rates above 12.5 MBd is possible provided PWD and data dependent jitter increases and relaxed noise margins are tolerable within the application. For instance, if the maximum allowable variation of bit width is 30%, the maximum data rate becomes 37.5 MBd. Please note that HCPL-0710 performance above 12.5 MBd is not guaranteed by Hewlett-Packard.
- PWD is defined as $|t_{PHL} - t_{PLH}|$. %PWD (percent pulse width distortion) is equal to the PWD divided by pulse width.
- t_{PSK} is equal to the magnitude of the worst case difference in t_{PHL} and/or t_{PLH} that will be seen between units at any given temperature within the recommended operating conditions.
- CM_H is the maximum common mode voltage slew rate that can be sustained while maintaining $V_O > 0.8 V_{DD2}$. CM_L is the maximum common mode voltage slew rate that can be sustained while maintaining $V_O < 0.8 \text{ V}$. The common mode voltage slew rates apply to both rising and falling common mode voltage edges.
- Unloaded dynamic power dissipation is calculated as follows: $C_{PD} * V_{DD2} * f + I_{DD} * V_{DD}$, where f is switching frequency in MHz.
- Device considered a two-terminal device: pins 1, 2, 3, and 4 shorted together and pins 5, 6, 7, and 8 shorted together.
- In accordance with UL1577, each optocoupler is proof tested by applying an insulation test voltage $\geq 3000 V_{RMS}$ for 1 second (leakage detection current limit, $I_{L-O} \leq 5 \mu\text{A}$).
- The Input-Output Momentary Withstand Voltage is a dielectric voltage rating that should not be interpreted as an input-output continuous voltage rating. For the continuous voltage rating refer to your equipment level safety specification or HP Application Note 1074 entitled "Optocoupler Input-Output Endurance Voltage."
- C_I is the capacitance measured at pin 2 (V_I).

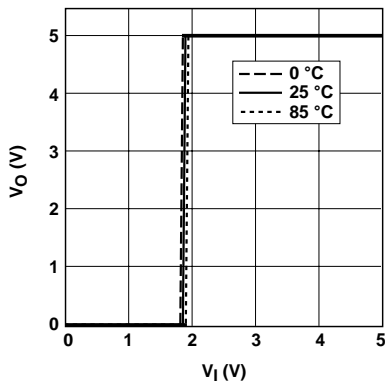

Figure 1. Typical Output Voltage vs. Input Voltage.

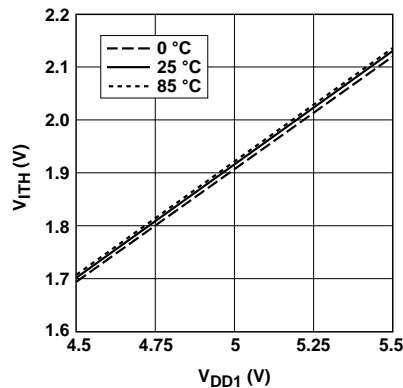

Figure 2. Typical Input Voltage Switching Threshold vs. Input Supply

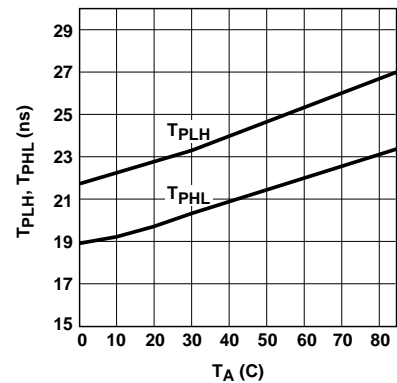

Figure 3. Typical Propagation Delays vs. Temperature.

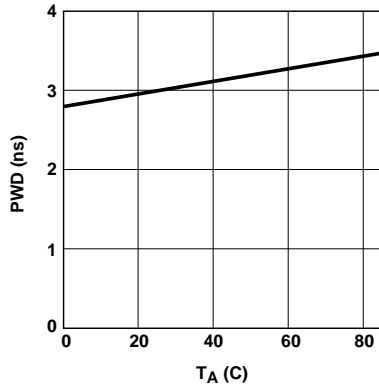

Figure 4. Typical Pulse Width Distortion vs. Temperature.

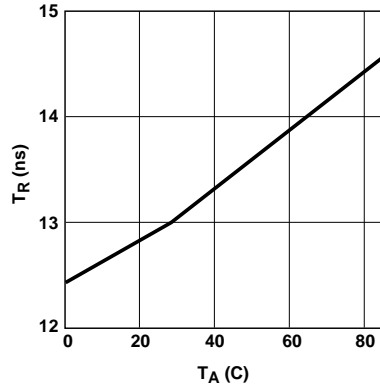

Figure 5. Typical Rise Time vs. Temperature.

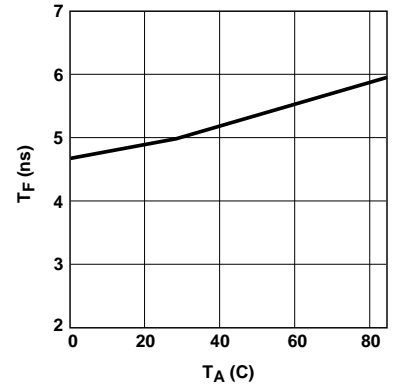

Figure 6. Typical Fall Time vs. Temperature.

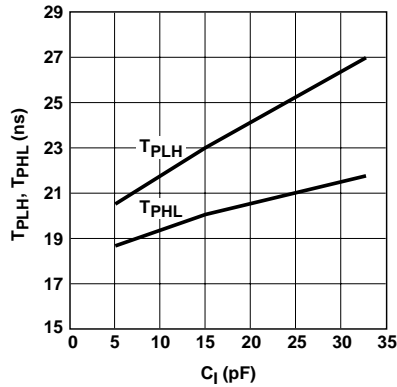

Figure 7. Typical Propagation Delays vs. Output Load Capacitance.

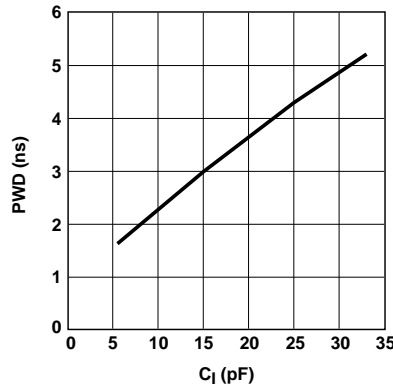

Figure 8. Typical Pulse Width Distortion vs. Output Load Capacitance.

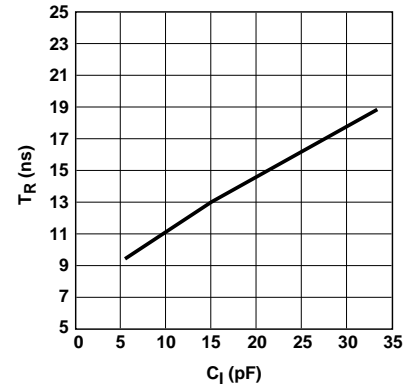

Figure 9. Typical Rise Time vs. Load Capacitance.

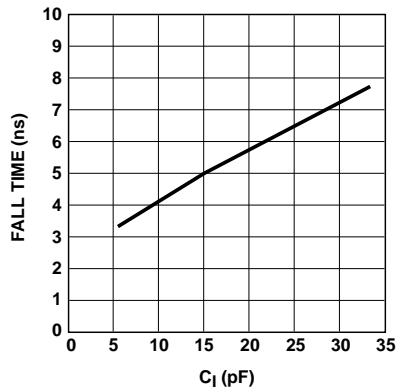

Figure 10. Typical Fall Time vs. Load Capacitance.

Application Information

Bypassing and PC Board Layout

The HCPL-0710 optocoupler is extremely easy to use. No external interface circuitry is required because the HCPL-0710 uses high-speed CMOS IC

technology allowing CMOS logic to be connected directly to the inputs and outputs.

As shown in Figure 11, the only external components required for proper operation are two bypass capacitors. Capacitor values should be between 0.01 μF and

0.1 μF . For each capacitor, the total lead length between both ends of the capacitor and the power-supply pins should not exceed 20 mm. Figure 12 illustrates the recommended printed circuit board layout for the HCPL-0710.

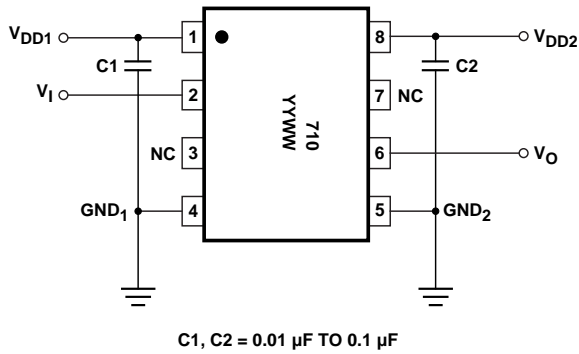

Figure 11. Recommended Printed Circuit Board Layout.

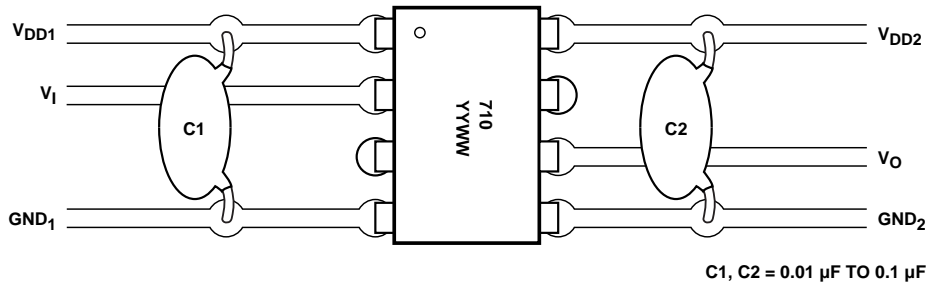

Figure 12. Recommended Printed Circuit Board Layout.

Propagation Delay, Pulse-Width Distortion and Propagation Delay Skew

Propagation Delay is a figure of merit which describes how quickly a logic signal propagates through a system. The propaga-

tion delay from low to high (t_{PLH}) is the amount of time required for an input signal to propagate to the output, causing the output to change from low to high. Similarly, the propagation delay from high to low (t_{PHL}) is the

amount of time required for the input signal to propagate to the output, causing the output to change from high to low. See Figure 13.

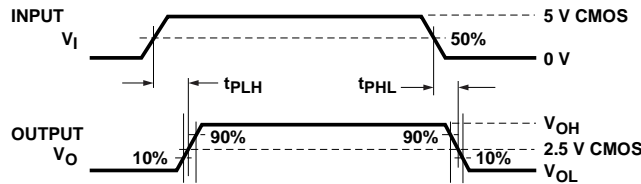

Figure 13.

Pulse-width distortion (PWD) is the difference between t_{PHL} and t_{PLH} and often determines the maximum data rate capability of a transmission system. PWD can be expressed in percent by dividing the PWD (in ns) by the minimum pulse width (in ns) being transmitted. Typically, PWD on the order of 20 - 30% of the minimum pulse width is tolerable. The PWD specification for the HCPL-0710 is 8 ns (10%) maximum across recommended operating conditions. 10% maximum is dictated by the most stringent of the three fieldbus standards, PROFIBUS.

Propagation delay skew, t_{PSK} , is an important parameter to consider in parallel data applications where synchronization of signals

on parallel data lines is a concern. If the parallel data is being sent through a group of optocouplers, differences in propagation delays will cause the data to arrive at the outputs of the optocouplers at different times. If this difference in propagation delay is large enough it will determine the maximum rate at which parallel data can be sent through the optocouplers.

Propagation delay skew is defined as the difference between the minimum and maximum propagation delays, either t_{PLH} or t_{PHL} , for any given group of optocouplers which are operating under the same conditions (i.e., the same drive current, supply voltage, output load, and operating

temperature). As illustrated in Figure 14, if the inputs of a group of optocouplers are switched either ON or OFF at the same time, t_{PSK} is the difference between the shortest propagation delay, either t_{PLH} or t_{PHL} , and the longest propagation delay, either t_{PLH} or t_{PHL} .

As mentioned earlier, t_{PSK} can determine the maximum parallel data transmission rate. Figure 15 is the timing diagram of a typical parallel data application with both the clock and data lines being sent through the optocouplers. The figure shows data and clock signals at the inputs and outputs of the optocouplers. In this case the data is assumed to be clocked off of the rising edge of the clock.

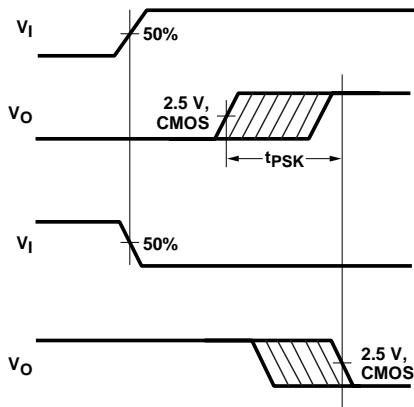

Figure 14. Propagation Delay Skew Waveform.

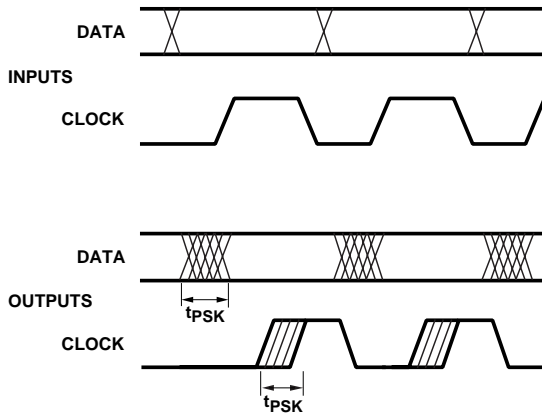

Figure 15. Parallel Data Transmission Example.

Propagation delay skew represents the uncertainty of where an edge might be after being sent through an optocoupler. Figure 15 shows that there will be uncertainty in both the data and clock lines. It is important that these two areas of uncertainty not overlap, otherwise the clock signal might arrive before all of the data outputs have settled, or

some of the data outputs may start to change before the clock signal has arrived. From these considerations, the absolute minimum pulse width that can be sent through optocouplers in a parallel application is twice t_{PSK} . A cautious design should use a slightly longer pulse width to ensure that any additional

uncertainty in the rest of the circuit does not cause a problem.

The HCPL-0710 optocoupler offers the advantage of guaranteed specifications for propagation delays, pulse-width distortion, and propagation delay skew over the recommended temperature and power supply ranges.

Digital Field Bus Communication Networks

To date, despite its many drawbacks, the 4 - 20 mA analog current loop has been the most widely accepted standard for implementing process control systems. In today's manufacturing environment, however, automated systems are expected to help

manage the process, not merely monitor it. With the advent of digital field bus communication networks such as DeviceNet, PROFIBUS, and Smart Distributed Systems (SDS), gone are the days of constrained information. Controllers can now receive multiple readings from field devices (sensors, actuators, etc.) in addition to diagnostic information.

The physical model for each of these digital field bus communication networks is very similar as shown in Figure 16. Each includes one or more buses, an interface unit, optical isolation, transceiver, and sensing and/or actuating devices.

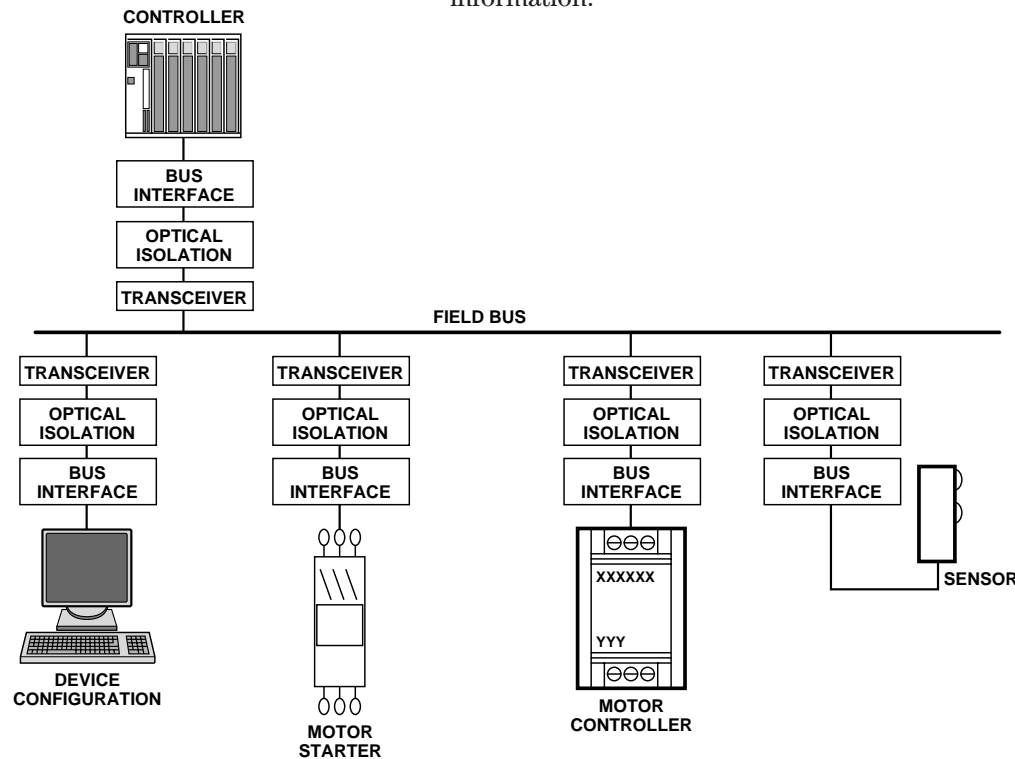

Figure 16. Typical Field Bus Communication Physical Model.

Optical Isolation for Field Bus Networks

To recognize the full benefits of these networks, each recommends providing galvanic isolation using Hewlett-Packard optocouplers. Since network communication is bi-directional (involving receiving data from and transmitting data onto the network), two Hewlett-Packard optocouplers are needed. By providing galvanic isolation, data integrity is retained via noise reduction and the elimination of

false signals. In addition, the network receives maximum protection from power system faults and ground loops.

Within an **isolated node**, such as the DeviceNet Node shown in Figure 17, *some* of the node's components are referenced to a ground other than V- of the network. These components could include such things as devices with serial ports, parallel ports, RS232 and RS485 type ports. As shown in Figure 17, power from

the network is used only for the transceiver and input (network) side of the optocouplers.

Isolation of nodes connected to any of the three types of digital field bus networks is best achieved by using the HCPL-0710 optocoupler. For each network, the HCPL-0710 satisfies the critical propagation delay and pulse width distortion requirements over the temperature range of 0°C to +85°C, and power supply voltage range of 4.5 V to 5.5 V.

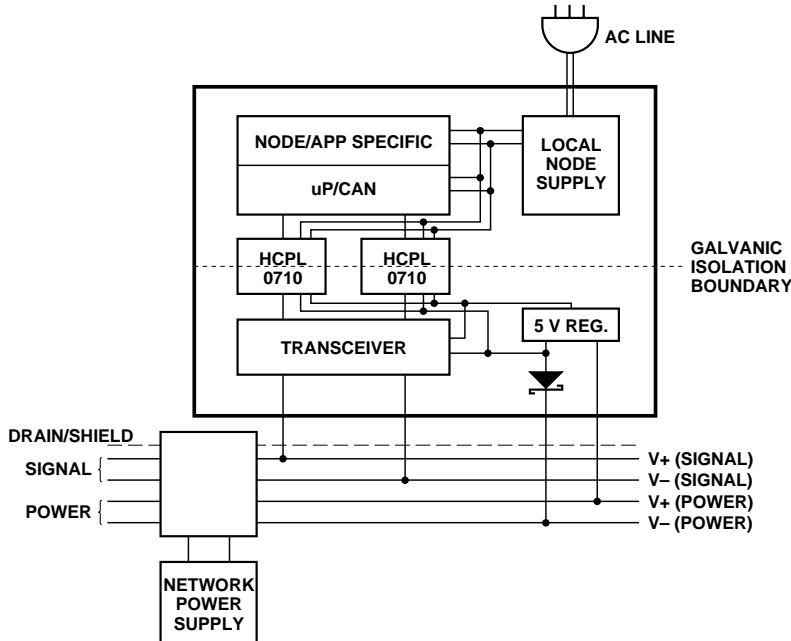

Figure 17. Typical DeviceNet Node.

Implementing DeviceNet and SDS with the HCPL-0710

With transmission rates up to 1 Mbit/s, both DeviceNet and SDS are based upon the same broadcast-oriented, communications protocol — the Controller Area Network (CAN). Three types of isolated nodes are recommended for use on these networks: Isolated Node Powered

by the Network (Figure 18), Isolated Node with Transceiver Powered by the Network (Figure 19), and Isolated Node Providing Power to the Network (Figure 20).

Isolated Node Powered by the Network

This type of node is very flexible and as can be seen in Figure 18, is regarded as “isolated” because not all of its components have the

same ground reference. Yet, all components are still powered by the network. This node contains two regulators: one is isolated and powers the CAN controller, node-specific application and isolated (node) side of the two optocouplers while the other is non-isolated. The non-isolated regulator supplies the transceiver and the non-isolated (network) half of the two optocouplers.

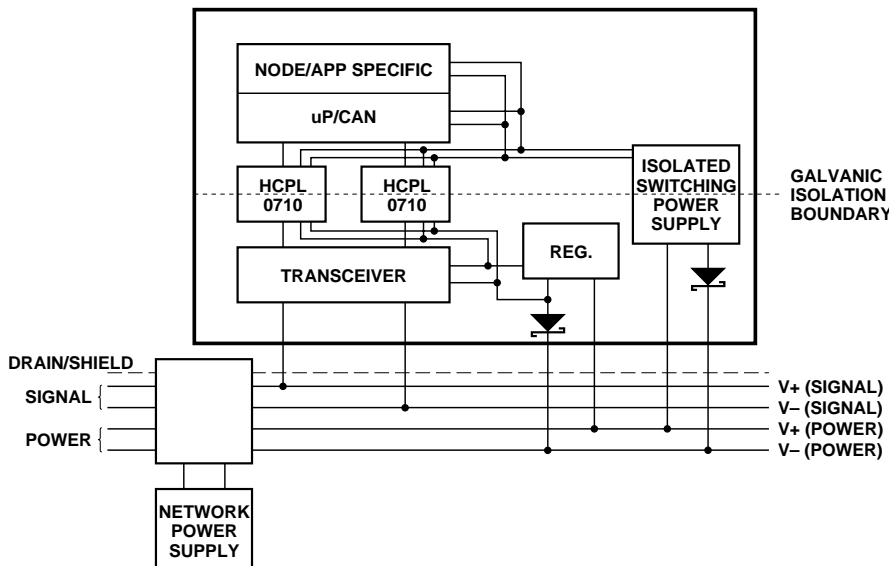

Figure 18. Isolated Node Powered by the Network.

Isolated Node with Transceiver Powered by the Network

Figure 19 shows a node powered by both the network and another source. In this case, the transceiver and isolated (network) side of the two optocouplers are

powered by the network. The rest of the node is powered by the AC line which is very beneficial when an application requires a significant amount of power. This method is also desirable as it does not heavily load the network.

More importantly, the unique “dual-inverting” design of the HCPL-0710 ensures the network will not “lock-up” if either AC line power to the node is lost or the node powered-off. Specifically, when input power (V_{DD1}) to the HCPL-0710 located in the transmit path is eliminated, a RECESSIVE bus state is ensured as the HCPL-0710 output voltage (V_O) goes HIGH.

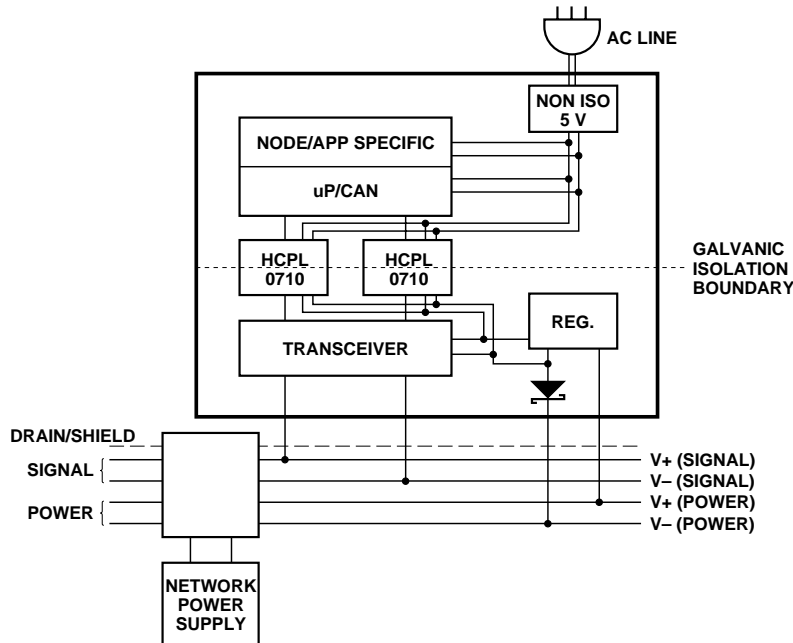

Figure 19. Isolated Node with Transceiver Powered by the Network.

Isolated Node Providing Power to the Network

Figure 20 shows a node providing power to the network. The AC line powers a regulator which provides five (5) volts locally. The AC line also powers a 24 volt isolated supply, which powers the network, and another five-volt

regulator, which, in turn, powers the transceiver and isolated (network) side of the two optocouplers. This method is recommended when there are a limited number of devices on the network that don't require much power, thus eliminating the need for separate power supplies.

More importantly, the unique "dual-inverting" design of the HCPL-0710 ensures the network will not "lock-up" if either AC line power to the node is lost or the node powered-off. Specifically, when input power (V_{DD1}) to the HCPL-0710 located in the transmit path is eliminated, a RECESSIVE bus state is ensured as the HCPL-0710 output voltage (V_O) goes HIGH.

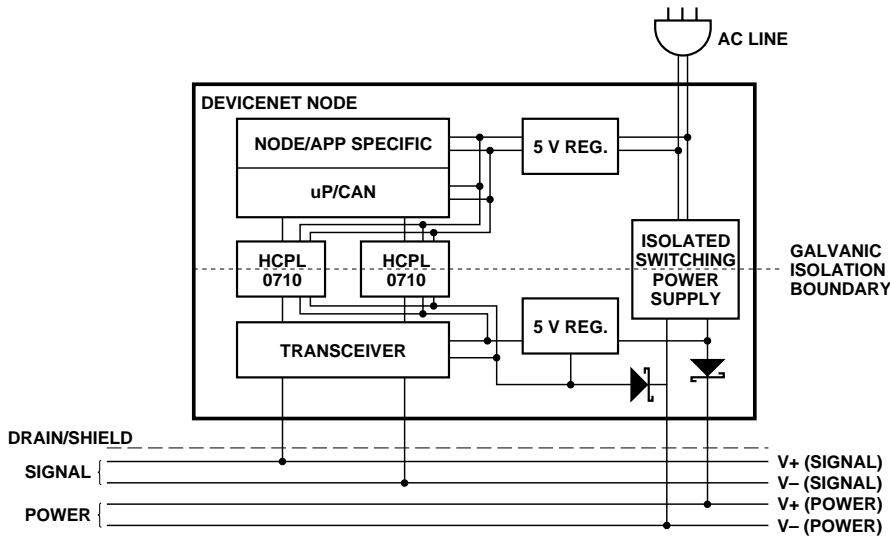

Figure 20. Isolated Node Providing Power to the Network.

Power Supplies and Bypassing

The recommended DeviceNet application circuit is shown in Figure 21. Since the HCPL-0710 is fully compatible with CMOS logic level signals, the optocoupler is connected directly to the

CAN transceiver. Two bypass capacitors (with values between 0.01 and 0.1 μF) are required and should be located as close as possible to the input and output power-supply pins of the HCPL-0710. For each capacitor, the

total lead length between both ends of the capacitor and the power supply pins should not exceed 20 mm. The bypass capacitors are required because of the high-speed digital nature of the signals inside the optocoupler.

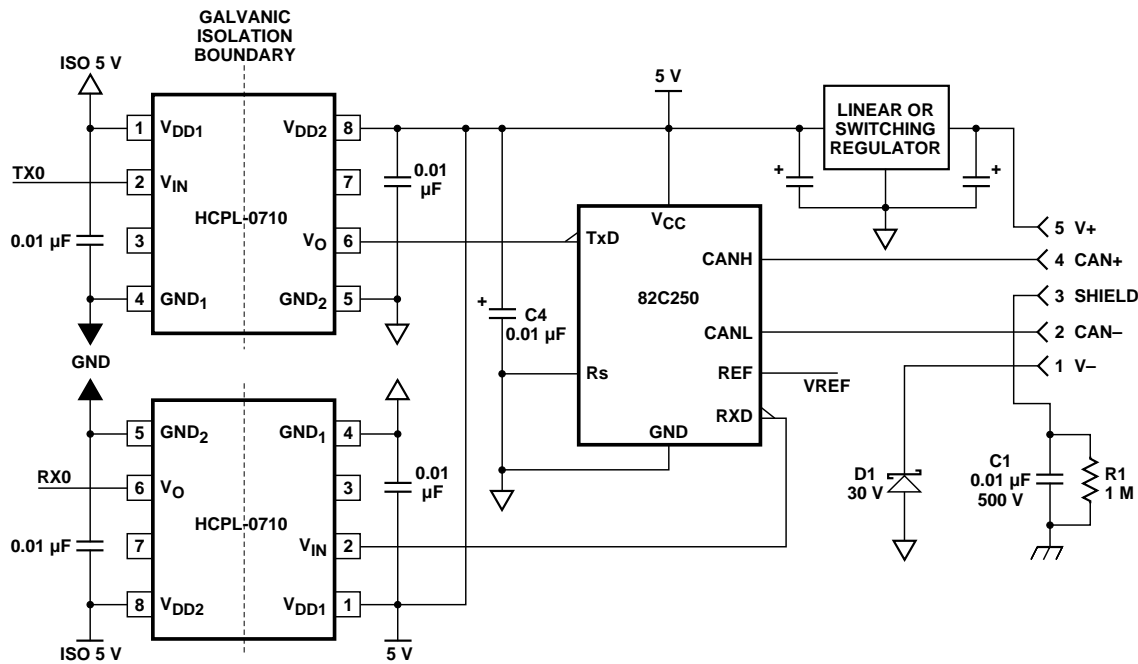

Figure 21. Recommended DeviceNet Application Circuit.

Implementing PROFIBUS with the HCPL-0710

An acronym for Process Fieldbus, PROFIBUS is essentially a twisted-pair serial link very similar to RS-485 capable of achieving high-speed communication up to 12 MBd. As shown in Figure 22, a PROFIBUS Controller (PBC) establishes the connec-

tion of a field automation unit (control or central processing station) or a field device to the transmission medium. The PBC consists of the line transceiver, optical isolation, frame character transmitter/receiver (UART), and the FDL/APP processor with the interface to the PROFIBUS user.

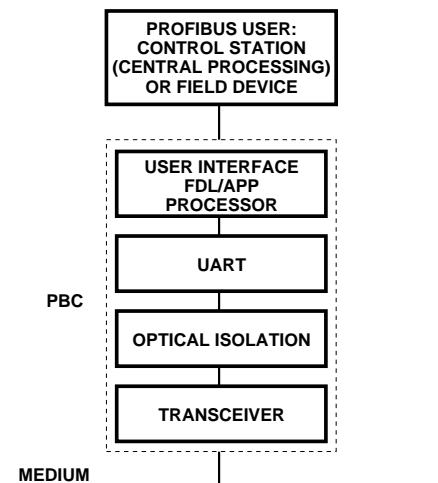

Figure 22. PROFIBUS Controller (PBC).

Power Supplies and Bypassing

The recommended PROFIBUS application circuit is shown in Figure 23. Since the HCPL-0710 is fully compatible with CMOS logic level signals, the optocoupler is connected directly to the transceiver. Two bypass capacitors (with values between 0.01 and 0.1 μF) are required and should be located as close as possible to the input and output

power-supply pins of the HCPL-0710. For each capacitor, the total lead length between both ends of the capacitor and the power supply pins should not exceed 20 mm. The bypass capacitors are required because of the high-speed digital nature of the signals inside the optocoupler.

Being very similar to multi-station RS485 systems, the HCPL-061N optocoupler provides a transmit disable function which is neces-

sary to make the bus free after each master/slave transmission cycle. Specifically, the HCPL-061N disables the transmitter of the line driver by putting it into a high state mode. In addition, the HCPL-061N switches the RX/TX driver IC into the listen mode. The HCPL-061N offers HCMOS compatibility and the high CMR performance (1 kV/ μs at $V_{\text{CM}} = 1000\text{ V}$) essential in industrial communication interfaces.

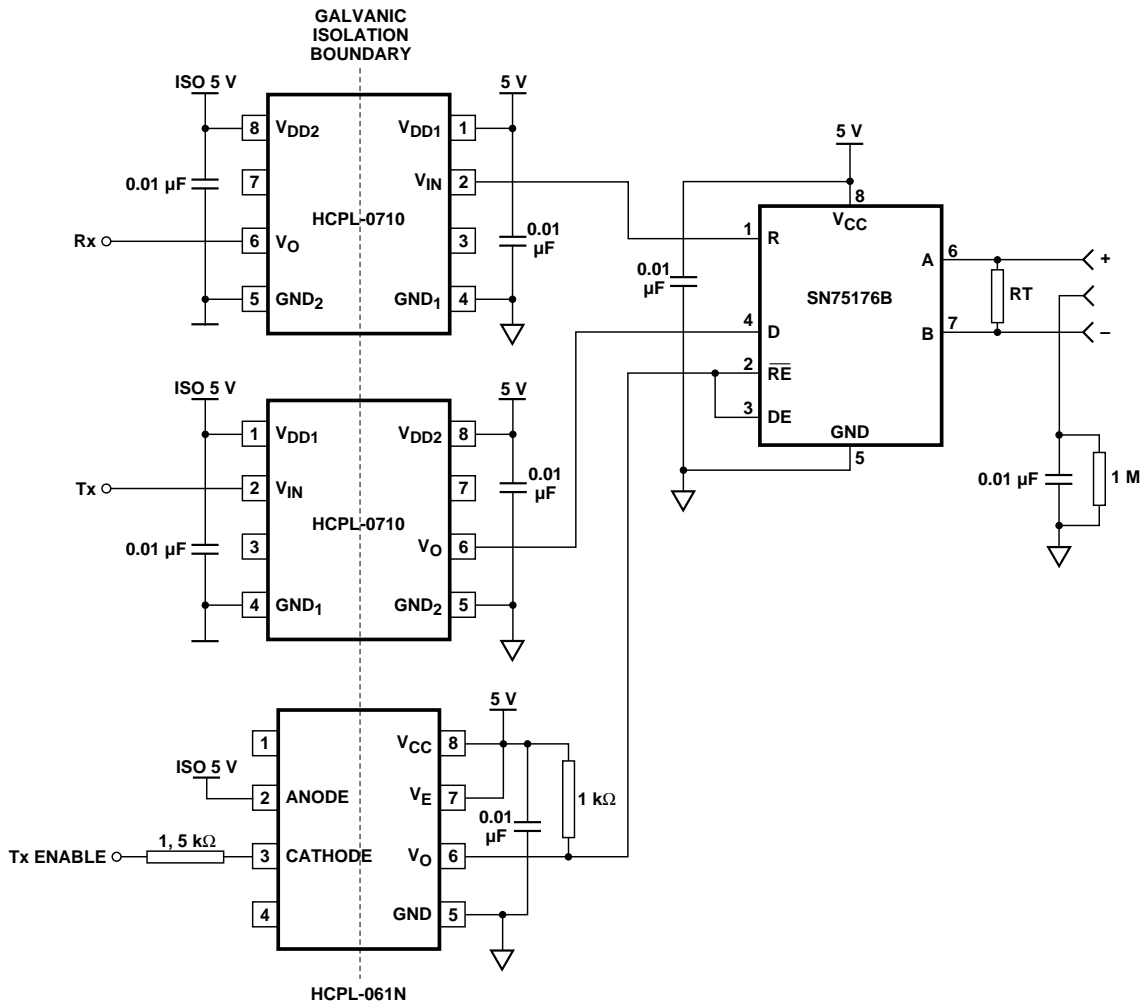

Figure 23. Recommended PROFIBUS Application Circuit.



For technical assistance or the location of your nearest Hewlett-Packard sales office, distributor or representative call:

Americas/Canada: 1-800-235-0312 or 408-654-8675

Far East/Australasia: Call your local HP sales office.

Japan: (81 3) 3335-8152

Europe: Call your local HP sales office.

Data subject to change.

Copyright © 1997 Hewlett-Packard Co.

Printed in U.S.A. 5965-6033E (1/97)