



Fibre Channel Transmitter and Receiver Chipset

Technical Data

HDMP-1512 Transmitter HDMP-1514 Receiver

Features

- ANSI X3.230-1994 Fibre Channel Standard Compatible (FC-0)
- Selectable 531.25 Mbaud or 1062.5 Mbaud Data Rates
- Selectable On Chip Laser Driver and 50 Ω Cable Driver
- TTL Compatible I/Os
- Single +5.0 V Power Supply

Applications

- Mass Storage System I/O Channel
- Work Station/Server I/O Channel
- High Speed Peripheral Interface

Description

The HDMP-1512 transmitter and the HDMP-1514 receiver are bipolar integrated circuits, separately packaged, in 80 pin M-Quad packages. They are used to build a high speed Fibre Channel link for point to point data communications. Shown in Figure 1 is a typical full duplex point-to-point Fibre Channel link. The sending system provides parallel, 8B/10B, encoded data and a transmit byte clock to the HDMP-1512 transmitter. Using the transmit byte clock, the transmitter

converts the data to a serial stream and sends it over a copper cable or fiber-optic link. The receiver converts the serial data stream back to parallel encoded data and presents it, along with the recovered transmit byte clock, to the receiving system. The sending system has the option to electrically wrap the transmitted data back to the local receiver. It is possible to transmit over the cable driver, or laser driver when data is being wrapped back to the local receiver.

The two-chip set (transmitter chip and receiver chip) is compatible with the FC-0 layer of the American National Standards Institute (ANSI), Fibre Channel specification, X3.230-1994. This specification defines four standard rates of operation for Fibre Channel links. The HDMP-1512 and HDMP-1514 chip-set will operate at the two highest defined serial rates of 531.25 Mbaud and 1062.5 Mbaud. These serial baud rates correspond to 8B/10B encoded byte rates of 50 Mbytes/sec and 100 Mbytes/sec respectively. The proper setting of a single pin on each chip selects the desired rate of operation.



Several features, exclusive to this chip-set, make it ideal for use in Fibre Channel links. In addition, the laser driver on the transmitter chip, the dual loss of light detectors on the receiver chip, and the power supervisor and power reset features make this chip-set ideal for use with laser optics. The serial cable driver (transmitter chip), and the cable equalizer (on the receiver chip), can be operated in conjunction with, or as an alternative to, the laser driver. The laser driver can also be driven directly with an external high speed serial input.

Altogether, the various features, input/output options, and flexibility of this chip-set make several unique link configurations possible. In particular, it is ideally suited for use in applications where conformance to the FCSI specification # 301-Rev 1.0, Gbaud Link Module Specification, is desired.



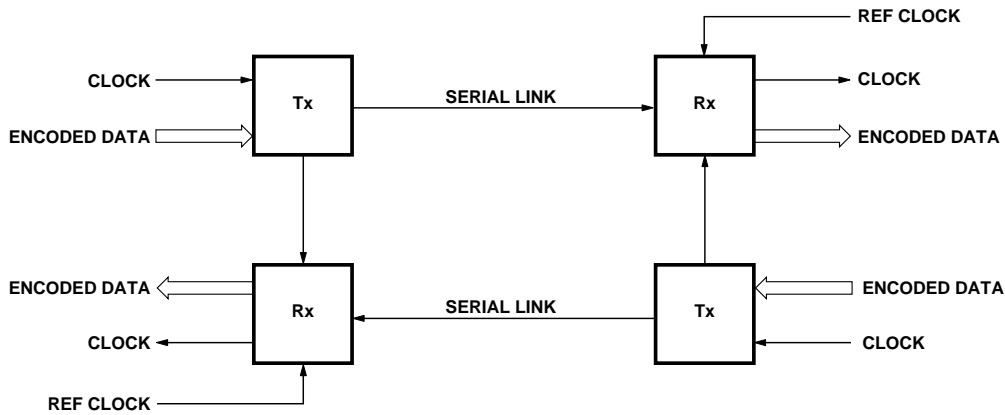

Figure 1. Point-to-Point Data Link.

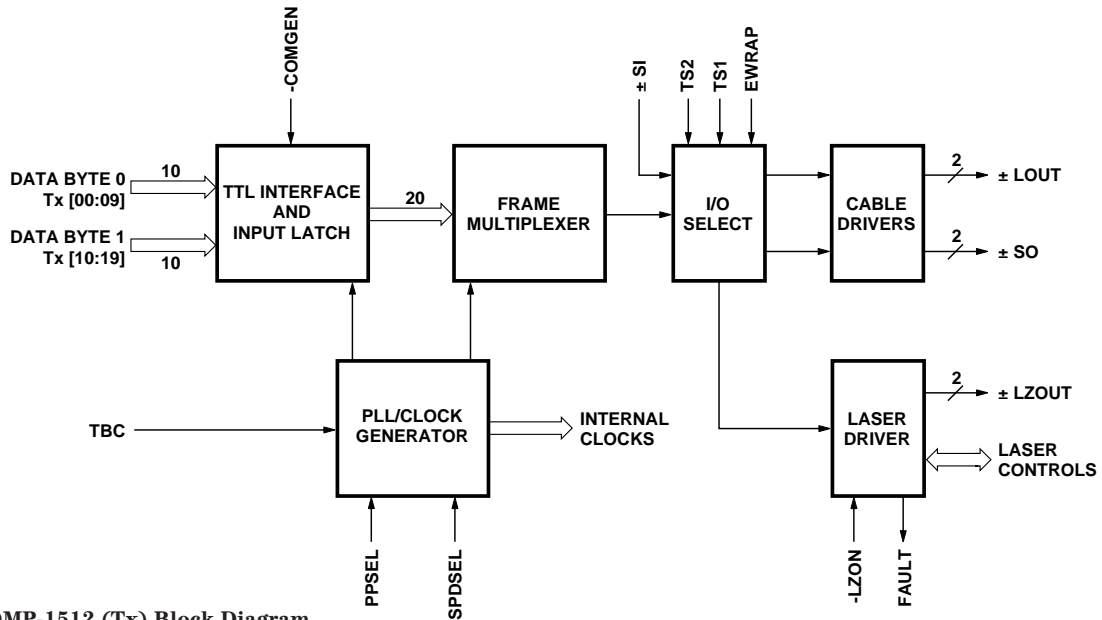

Figure 2. HDMP-1512 (Tx) Block Diagram.

Transmitter Operation

The block diagram of the HDMP-1512 transmitter is shown in Figure 2. The basic functions of the transmitter chip are the TTL Interface and Input Latch, Frame Multiplexing, Input/Output selection, cable drivers, Laser Driver, and monolithic Phase Locked loop clock generator. The actual operation of each function changes slightly, according to the desired configuration and option settings. Figures 18 and 19 show schematically how to terminate each pin on the HDMP-1512 when used in systems incorporating either copper or fiber media.

There are two main modes of operation for the transmitter chip, both are based on the selected baud rate. The baud rate is controlled by the appropriate setting of the SPDSEL pin, #67. When this pin is set low, the transmitter operates at a serial rate of 531.25 Mbaud. When pin #67 is set high the transmitter operates at a serial rate of 1062.5 Mbaud. As such, the two main modes of operation are the 531.25 Mbaud mode and the 1062.5 Mbaud mode.

The transmitter does not encode the applied data. It assumes the

data is pre-encoded using the 8B/10B encoding scheme as defined in ANSI X3.230-1994. The TTL input interface receives data at the standard TTL levels specified in the dc Electrical Specification table. The internal phase locked loop (PLL) locks to the transmit byte clock, TBC. TBC is supplied to the transmitter chip by the sending system. TBC should be a 53.125 MHz clock (± 100 ppm) as defined in X3.230-1994. Once the PLL has locked to TBC, all the clocks used by the transmitter are generated by the internal clock generator.

When operating in the 531.25 Mbaud mode, data byte 0, Tx[00:09], is active and is clocked into the input latch a single byte (10 bits) on each rising edge of TBC. In the 1062.5 Mbaud mode both data byte 0, Tx[00:09], and data byte 1, Tx[10:19], are active. In 1062.5 Mbaud mode, data byte 0 and data byte 1 are clocked into the transmitter on the rising edge of every clock cycle, (TBC). There is one minor variation possible in the 1062.5 Mbaud mode, referred to as “ping-pong” mode. Ping-pong mode is selected by setting the PPSEL pin (#34) high. In this mode the transmitter clocks data into the input latch one byte per half clock cycle. Data byte 0 is transmitted on the rising edge of TBC and data byte 1 is transmitted 1/2 clock cycle later. See Figure 16 for timing information.

The input latch will stop sending the data applied to the Tx[00:09] data pins when a low is applied to the -COMGEN pin (#32) and will send the pre-set special Fibre Channel character, K28.5 instead. The 8B/10B coding scheme, adopted by Fibre Channel, converts 8 bit data words into 10 bit representations of the actual data. Of all the possible combina-

tions of 10 bit binary words, the 8B/10B code reserves 256 of them to represent the valid combinations of 8 bit data. Some of the remaining combinations are reserved for special functions. The character reserved for defining the transmitted word boundary has been defined as the K28.5 character, also known as a comma character. The receiver will automatically reset registers and clock when it receives a comma character (this will be discussed in more detail in the receiver operation section). Every valid 8 bit data word is actually represented by one of two 10 bit codes, indicating either positive or negative running disparity. The input latch only generates the K28.5 character with positive disparity (0011111010).

In Figure 2, the Frame Multiplexer utilizes shift registers and a multi-stage multiplexing scheme to convert the 10 or 20 parallel data bits to a serial data stream. This serial data stream is then fed directly into the Input/Output Select portion of the transmitter.

The I/O Select function allows use of both the internally serialized Fibre Channel data stream and an

externally supplied Fibre Channel data stream denoted as \pm SI (pins 11 and 12). By using the proper settings of TS1, TS2, and EWRAP (pins 76, 75, and 71 respectively), the internal data stream and the external data stream can be directed to various combinations of the cable driver output, the laser driver output, and the electrical loopback output. The possible I/O combinations are listed in the Input Output Select Table and the functionality is described in more detail in the Transmitter Laser Driver Operation section below.

The cable driver function provides a 50 Ω differential cable driver output at pins 5 and 6 (\pm SO). The simplified circuit is the O-BLL section shown in Figure 10. A similar output is provided to allow electrical loopback, or wrap of the local data back to the local receiver for diagnostics. This is denoted as \pm LOU on pin 8 and pin 9.

The final function on the transmitter chip is the Laser Driver block which provides a high speed differential output, \pm LZOUT, at pins 19 and 20. There are several other laser control I/Os which will be

HDMP-1512 Input Output Select Table

Mode	TS1	TS2	EWRAP	Data Source For:			Active Outputs		
				\pm SO	\pm LZOUT	\pm LOU	\pm SO	\pm LZOUT	\pm LOU
0	0	0	0	NA	Internal	NA	no	yes	no
1	0	0	1	NA	NA	Internal	no	no	yes
2	0	1	0	Internal	Internal	NA	yes	yes	no
3	0	1	1	Internal	NA	Internal	yes	no	yes
4	1	0	0	Internal	NA	NA	yes	no	no
5	1	0	1	NA	Internal	Internal	no	yes	yes
6	1	1	0	Internal	\pm SI	NA	yes	yes	no
7	1	1	1	Internal	NA	\pm SI	yes	no	yes

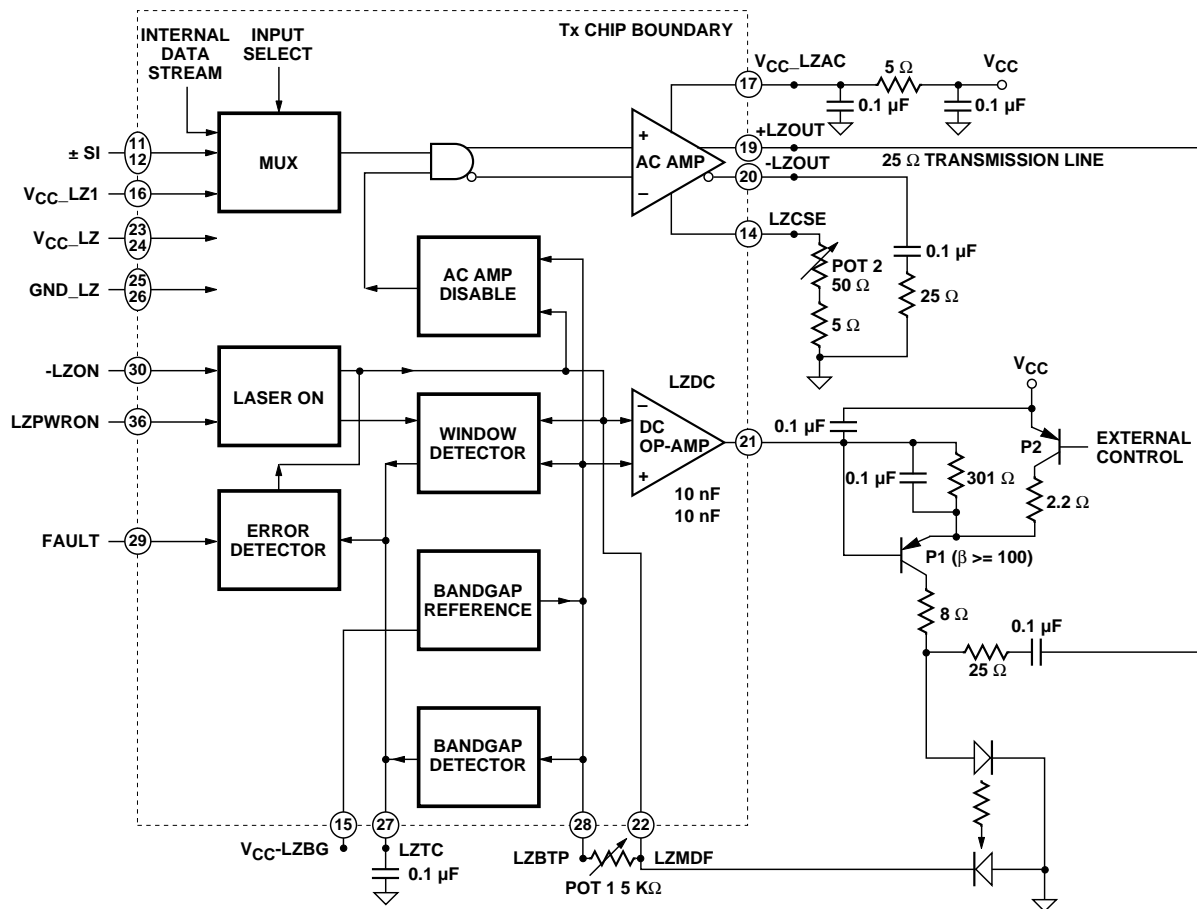

Figure 3. Laser Driver Block Diagram and External Circuitry.

described in more detail in the laser driver operation section below.

Transmitter Laser Driver Operation

The block diagram of the HDMP-1512, Tx, laser driver circuitry is shown in Figure 3. The laser driver is enabled by setting -LZON (pin 30) low and LZWPRON (pin 36) high. The circuitry in Figure 3, shown outside the chip boundary (dotted box), illustrates the external components required to complete a typical laser driver connection.

The input data source to the laser driver is user selected from either the internally generated data stream, or an externally supplied high speed data stream. The externally supplied data stream is applied to the high speed input

\pm SI pins. The user selects between these two data sources through the proper settings of pins TS1, TS2, and EWRAP (pins 76, 75, and 71). The possible combinations of active inputs and outputs are shown in the Input/Output Select Table. The chosen high speed input is then modulated onto the laser by the ac amplifier. The external potentiometer, Pot 2, shown connected to pin LZCSE (# 14) is used to adjust the laser modulation depth. The laser driver output is at pins 19 and 20, \pm LZOUT. Laser diode dc bias control is provided through the LZDC (# 21) pin. Adjustment of Pot 1 sets the nominal dc bias desired for the laser diode. The equivalent output circuit of LZDC is shown in Figure 4. Laser diode fault and safety control is implemented through the combination

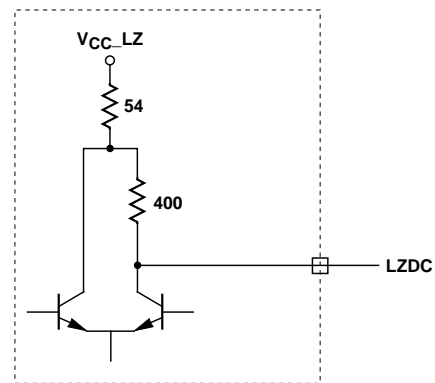

Figure 4. LZDC Equivalent Output Circuit (Tx pin # 21).

of the window detector, error detector, Laser On pin # 30 (-LZON), laser monitor diode feedback pin # 22 (LZMDF), and the op-amp dc bias control circuit. The window detector monitors the voltage on pin LZMDF. If this voltage goes out of range by more than \pm 10% from the nominal setting, the

capacitor on pin LZTC (# 27) will begin to discharge. After approximately 2 msec, the voltage on LZTC falls to the fault value and the error detector will bring the FAULT pin (# 29) high to alert the system. The error detector will also hold the voltage on LZMDF low, until a reset is initiated.

The -LZON pin is used to disable the laser driver under system control or in conjunction with an external open-fiber control (OFC) chip. This pin is also used to reset the error detector and recharge the capacitor on pin LZTC.

The LZPWRON pin, # 36, is used to hold off dc power to the laser driver until proper dc bias is applied to the laser diode. When LZPWRON goes high, the laser driver is enabled, when it is low, it is disabled. If not used, this pin should be tied low.

Receiver Operation

The block diagram of the HDMP-1514 receiver is shown in Figure 5. The functions included on the receiver are a coaxial cable equalizer, two independent loss of light (LOL) detectors, an input select function, monolithic phase locked loop and clock recovery circuits, a clock generator, frame demultiplexer and comma detector, power supply supervisor, and output latch with TTL drivers. Figures 20 and 21 show schematically how to terminate each pin on the HDMP-1514 when used in systems incorporating either copper or fiber media.

In the most basic sense, the receiver accepts a serial electrical data stream at 1062.5 Mbaud or 531.25 Mbaud and recovers the 8B/10B encoded parallel data and clock that was applied to the transmitter. Like the transmitter, the receiver has several configuration options which interrelate

according to the desired mode of operation.

The two main modes of operation for the receiver are based on the desired signalling rate. The signalling rate is controlled by the proper setting of the SPDSEL pin # 71. When this pin is set low, the receiver operates at a serial rate of 531.25 Mbaud. When pin # 71 is set high, the receiver operates at a serial rate of 1062.5 Mbaud.

In a typical configuration, the serial electrical data stream will be applied to the \pm DI pins, # 19 and # 20 on the receiver. The serial electrical data stream may have been transmitted over a fiber optic link or a copper cable link (several variations of each link type is possible). For use with copper links, a selectable cable equalizer is available at the input. This equalizer can be switched into or out of the data

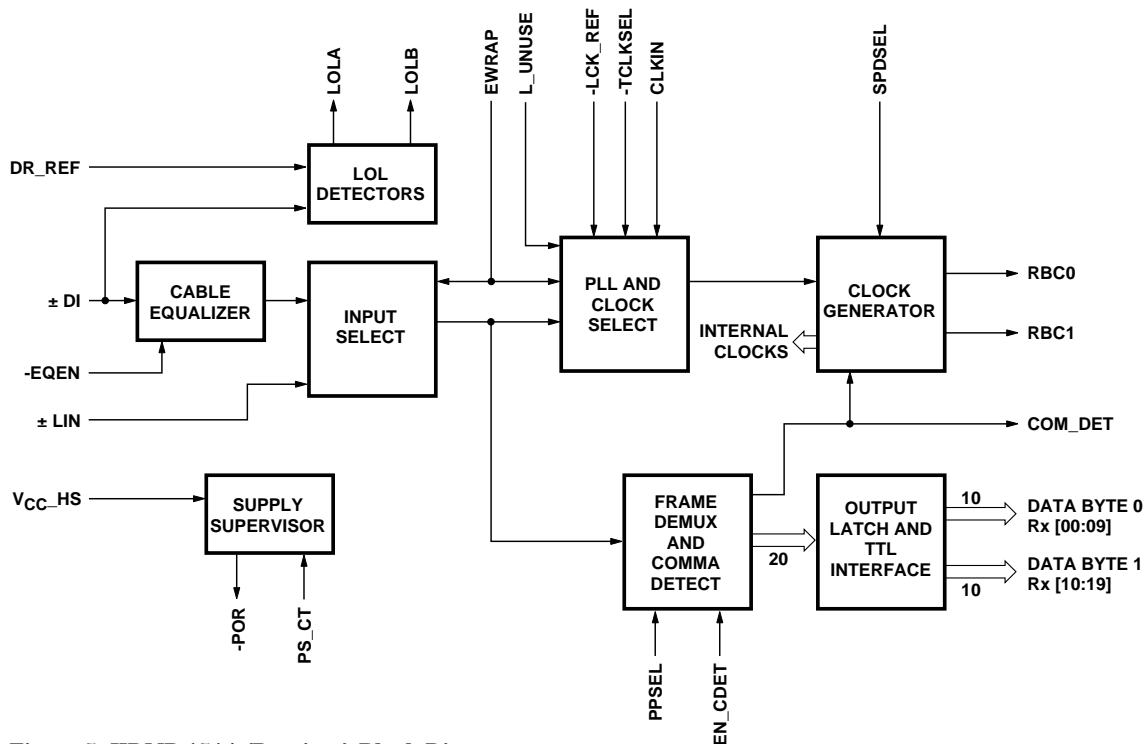

Figure 5. HDMP-1514 (Receiver) Block Diagram.

path using the -EQEN pin, # 32. Setting pin #32 high disables the equalizer. Setting pin # 32 low enables the equalizer. The typical performance of the input equalizer is shown in the (frequency response) plot of Figure 7. The impact of the equalizer is improved BER performance over long lengths of cable (10 to 20 meters).

Connected to the \pm DI input pins, prior to the equalizer, are the loss of light detectors, LOLA (pin 28) and LOLB (pin 29). Actually, since these detectors monitor the incoming serial electrical data stream, they can be thought of as loss of “signal” detectors. These signals can be used to determine if the incoming signal line is connected properly. In the case of a fiber optic system they can be used to shut down laser output power for laser safety considerations. The LOL detectors measure transitions in the incoming data stream that exceed a pre-set peak-to-peak differential signal or threshold level. The default peak-to-peak differential threshold voltage is 25 mV and can be adjusted by connecting a resistive divider to the DR_REF pin (#21) as shown in Figure 6. The rela-

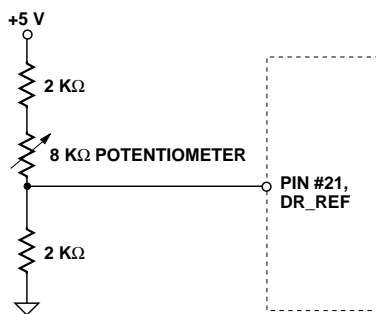

Figure 6. Simple Circuit Used to Adjust the Voltage on Rx pin # 21, DR_REF.

tionship of the DR_REF voltage to the peak-to-peak differential threshold voltage is shown in Figure 8. When the input signal level falls below the threshold voltage for 4 clock cycles, or 80 bit times, the signals at pins 28 and 29 will go high.

Once the serial data stream passes the cable equalizer function it is directed to an Input Select section. A second high speed serial data input, denoted \pm LIN, is applied at pins # 16 and # 17 and is connected directly to the Input Select section. This data input is intended for diagnostic purposes. It is not affected by the cable equalizer and has no effect on the loss of light detectors. The \pm LIN input should mainly be used when it is desired to directly connect the local transmitter serial output data stream to the local receiver (local loopback). The Input Select function uses the EWRAP signal, pin # 34, to determine which serial data stream to pass on to the rest of the receiver. If EWRAP is high, then the \pm LIN signal is used. If EWRAP is low the \pm DI signal is used.

The PLL and Clock select circuitry contains a monolithic, tunable, oscillator. This oscillator phase locks to the selected high speed data input and recovers the high speed serial clock. To keep the internal oscillator tuned close to the incoming signal frequency, an external reference oscillator is applied to the CLKIN input, pin # 7. The signal on the -LCK_REF input, pin # 36, controls whether the receiver oscillator locks to the reference oscillator or to the

incoming data stream. When -LCK_REF is toggled low, the receiver frequency locks to the signal at CLKIN. When the -LCK_REF pin is toggled high, the receiver phase locks to the selected high speed serial data input. This process of locking to a local reference oscillator, prior to receiving incoming data, improves (shortens) the overall time required by the receiver to acquire lock. The LUNUSE input, pin 73 will cause the receiver to frequency lock on the CLKIN signal under faulty or no input signal conditions. The LUNUSE signal needs to be provided to the receiver by an external open fiber control circuit or other control logic. Once the receiver has locked to the incoming data stream at \pm DI (EWRAP = 0 and -LCKREF = 1), if LUNUSE toggles high then the receiver will switch to frequency lock on CLKIN. If, however, the receiver is locked onto the local data wrapped back to the \pm LI input (EWRAP = 1 and -LCKREF = 1) then the receiver stays locked to the incoming signal at \pm LI even when LUNUSE goes high. In summary, when the LUNUSE input is set low, the receiver frequency locks to the CLKIN signal when the input to -LCKREF is low and phase locks to either the \pm DI or \pm LI signal, depending on which input is selected, when -LCKREF toggles high. LUNUSE then, is used to cause the receiver to frequency lock to the reference oscillator at CLKIN after the receiver has established phase lock to the incoming data signal at \pm DI, and the system determines the link is faulty and not in EWRAP mode.

-LCK_REF	EWRAP	LUNUSE	Rx Lock
0	x	x	CLKIN
1	0	0	DI
1	0	1	CLKIN
1	1	1	LI
1	1	0	LI

The table above illustrates these various settings.

Normally, the recovered serial clock is used by the clock generator to generate the various internal clocks the receiver uses including the receive clock outputs RBC0 (pin 69) and RBC1 (pin 67).

The final receiver clocking feature is included for test purposes only. By applying a low to the -TCLKSEL input, pin 5, the internal phase locked loop is bypassed and the receiver uses the CLKIN signal as the high speed serial clock. Under normal operating conditions the -TCLKSEL pin should be tied high.

In a Fibre Channel link, frame alignment is accomplished through the transmission and detection of the special character K28.5, also known as a comma character. Prior to actual data transmission the system will transmit a comma character over the physical link. To start, the receiver should be frequency locked to the local reference oscillator (-LCKREF set low). To ensure frequency lock is achieved, -LCKREF should be held low for a minimum of 500 μ sec (see Rx Timing Characteristics, t_{flock}). It then should be toggled high. At this point the receiver will phase lock to the

incoming data stream at the \pm DI input but the actual frame or word boundary will be undetermined. The EN_CDET pin (# 38) should be set high now. With the EN_CDET pin set high, the receiver will scan the incoming data stream for a comma character. Once a comma character is received, the internal clocks and registers are reset giving proper frame alignment. The receiver will reset on every comma character that is transmitted as long as EN_CDET is held high. When the internal clock generator is reset due to the detection of a comma character, internal circuitry prevents a clock “sliver” from appearing at the receive clock outputs (RBC0 and RBC1). This antisliver circuit assures each clock output high, or low, will be held for at least one half the frame rate time. When EN_CDET is set low the receiver ignores all incoming comma characters and assumes the current frame and bit alignment is correct. EN_CDET is automatically disabled when -LCKREF is set low. The COM_DET pin, #75, on the receiver will go high when a comma character is detected (see Figure 15).

Now that frame alignment has been achieved, the receiver is ready to receive full speed serial data and demultiplex it back to its original 10 bit or 20 bit

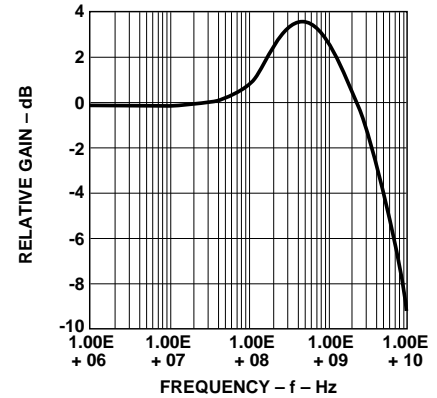

Figure 7. Typical Frequency Response Plot of the Internal Input Equalizer.

parallel word format. This data is then placed into the output latch. The data output is presented in the standard TTL output levels and characteristics specified in the dc and ac Electrical Specification tables. When operating in 531 Mbaud mode the receiver generates output data in a single byte wide (10 bits) output format. This is data byte 0 and is denoted RX[00:09] on pins 53 through 62. In 1063 Mbaud mode the data output is generated in a two byte wide (20 bits) format, data byte 0 and data byte 1. Data byte 0 is denoted RX[00:09] on pins 53 through 62 and data byte 1 is denoted RX[10:19] on pins 43 through 52. In standard operation data byte 0 and data byte 1 will both be clocked into the output latch at the same time, on the falling edge of RBC0. An alternate mode of operation is ping-pong mode. In ping-pong mode the data is clocked out 1 byte at a time with byte 0 clocked out on the falling edge of RBC0 and byte 1 clocked out on the falling edge of RBC1. To set the receiver to operate in ping-pong mode, the PPSEL pin, # 76, should be set high (otherwise it should be tied low).

Rx Power Supply Supervisor

A power supply supervisor feature has been designed into the receiver as a system aid during power-up. The -POR (pin # 27) output is held low until the power supply voltage (V_{CC}) crosses the nominal threshold of 4.25 volts. Then, following a delay time determined by the capacitor value connected to the PS_CT pin (# 22), the -POR output goes high. The typical delay time is 8 msec, with a 0.47 μ F capacitor attached to PS_CT.

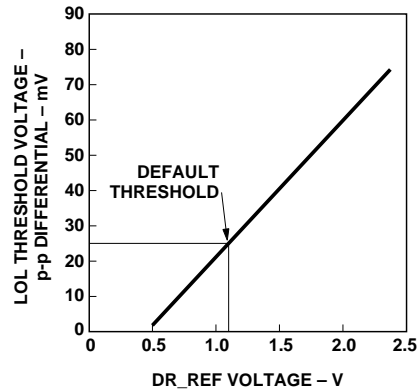

Figure 8. Typical Plot of Loss of Light Threshold Voltage vs. DR_REF Voltage.

Recommended Handling Precautions

Additional circuitry is built into the various input and output pins on these chips to protect them against low level electrostatic discharge, however, they are still ESD sensitive and standard procedures for static sensitive devices should be used in the handling and assembly of the HDMP-1512 and the HDMP-1514. The packing materials used for shipment of these devices was selected to provide ESD protection and to prevent mechanical damage.

During test and use, under power-up conditions, extreme care should be taken to prevent the high speed I/Os from being connected to ground as permanent damage to the device is likely.

HDMP-1512 (Tx), HDMP-1514 (Rx)

Absolute Maximum Ratings

Operation in excess of any one of these conditions may result in permanent damage.

Symbol	Parameter	Units	Min.	Max.
V_{CC}	Supply Voltage	V	-0.5	6.0
$V_{IN,TTL}$	TTL Input Voltage	V	-0.7	$V_{CC} + 0.7$
$V_{IN,H50}$	I-H50 Input Voltage, Figure 9	V	$V_{CC} - 2.0$	$V_{CC} + 0.7$
$I_{O,TTL}$	TTL Output Source Current	mA		13
T_{stg}	Storage Temperature	$^{\circ}$ C	-40	+130
T_J	Junction Operating Temperature	$^{\circ}$ C	0	+130
T_{max}	Maximum Assembly Temperature (for 10 seconds maximum)	$^{\circ}$ C	0	+260

HDMP-1512 (Tx), HDMP-1514 (Rx)

Specified Operating Rates

$T_C = 0^{\circ}$ C to $+85^{\circ}$ C, $V_{CC} = 4.5$ V to 5.5 V

SPDSEL	Transmit Byte Clock (TBC) (MHz)		Serial Baud Rate (MBaud/sec)	
	Min.	Max.	Min.	Max.
0	52.0	54.0	520	540
1	52.0	54.0	1040	1080

HDMP-1512 (Tx), HDMP-1514 (Rx)

Transmitter & Receiver Byte Rate Clock Requirements

$T_C = 0^\circ\text{C}$ to $+85^\circ\text{C}$, $V_{CC} = 4.5\text{ V}$ to 5.5 V

Symbol	Parameter	Unit	Min.	Typ.	Max.
f	Nominal Frequency	MHz	53.120	53.125	53.130
F _{tol}	Frequency Tolerance (For Fibre Channel Compliance)	ppm	-100		+100
Symm	Symmetry (Duty Cycle)	%	40		60

HDMP-1512 (Tx), HDMP-1514 (Rx)

AC Electrical Specifications

$T_C = 0^\circ\text{C}$ to $+85^\circ\text{C}$, $V_{CC} = 4.5\text{ V}$ to 5.5 V , Unless Otherwise Specified

Symbol	Parameter	Units	Min.	Typ.	Max.
$t_{r,TTLin}$	Input TTL Rise Time, 20% to 80%	nsec		2	
$t_{f,TTLin}$	Input TTL Fall Time, 20% to 80%	nsec		2	
$t_{r,TTLout}$	Output TTL Rise Time, 20% to 80%, 15 pF Load	nsec		2	4
$t_{f,TTLout}$	Output TTL Fall Time, 20% to 80%, 15 pF Load	nsec		2	4
$t_{r,BLL}$	BLL Rise Time, AC Coupled, 50 Ω source and load, 20% to 80%	psec		150	350
$t_{f,BLL}$	BLL Fall Time, AC Coupled, 50 Ω source and load, 20% to 80%	psec		150	350
VS _{WRi,H50}	H50 Input VSWR, AC Coupled, 50 Ω source and load			2.0	
VS _{WRo,BLL}	BLL Output VSWR, AC Coupled, 50 Ω source and load			2.0	
V _{IP,H50}	H50 Input Peak-to-Peak Differential Voltage, AC Coupled, 50 Ω Source	mV	50	1200	2000
LOL _{Th}	Loss of Light Threshold, Peak-to-Peak, Differential, $T_C = 60^\circ\text{C}$, $V_{CC} = 5.0\text{ V}$	mV	13	25	40
V _{OP,BLL}	BLL Output Peak-To-Peak Differential Voltage, AC Coupled, 50 Ω Load	mV	1200	1400	
PS _{DT}	Power Supervisor Delay Time, with PS_CT terminated in 0.47 μF	msec		15	

HDMP-1512 (Tx)

Output Jitter Characteristics

$T_C = 0^\circ\text{C}$ to $+85^\circ\text{C}$, $V_{CC} = 4.5\text{ V}$ to 5.5 V

Symbol	Parameter	Units	Min.	Typ.	Max.
RJ	RMS Random Jitter at SO, the High Speed Electrical Data Port	psec		10	
DJ	RMS Deterministic Jitter at SO, the High Speed Electrical Data Port	psec		22	

HDMP-1512 (Tx), HDMP-1514 (Rx)

DC Electrical Specifications

$T_C = 0^\circ\text{C}$ to $+85^\circ\text{C}$, $V_{CC} = 4.5\text{ V}$ to 5.5 V

Symbol	Parameter	Unit	Min.	Typ.	Max.
$V_{IH,TTL}$	TTL Input High Voltage Level, Guaranteed high signal for all inputs, $I_{IH} = 100\ \mu\text{A}$	V	2		5
$V_{IL,TTL}$	TTL Input Low Voltage Level, Guaranteed low signal for all inputs, $I_{IL} = -1\text{mA}$	V	0		0.8
$V_{OH,TTL}$	TTL Output High Voltage Level, $I_{OH} = 1\text{ mA}$	V	2.4		5
$V_{OL,TTL}$	TTL Output Low Voltage Level, $I_{OL} = -1\text{ mA}$	V	0		0.6
$I_{CC,Tx}$	Transmitter V_{CC} Supply Current, without laser biased	mA		320	450
$I_{CC,Rx}$	Receiver V_{CC} Supply Current, with TTL output data 50% 1's	mA		400	550
PS_{TH}	Power Supervisor DC Threshold Voltage	V	4.0	4.25	4.5

HDMP-1512 (Tx)

Laser Driver Characteristics

$T_C = 0^\circ\text{C}$ to $+85^\circ\text{C}$, $V_{CC} = 4.5\text{ V}$ to 5.5 V

Symbol	Parameter	Units	Min.	Typ.	Max.
I_{pb}	Laser Diode Prebias Current Set Range (Using External pnp Transistor, P1 in Figure 3, with $\beta > 100$)	mA		20	130
I_{mod}	Laser Diode Modulation Current Set Range (Peak to Peak) into $25\ \Omega$ Load	mA	25		
$t_{r,LZOUT}$	Laser Driver Rise Time, $25\ \Omega$ load, 20% to 80%	psec		325	
$t_{f,LZOUT}$	Laser Driver Fall Time, $25\ \Omega$ load, 20% to 80%	psec		325	
t_{LZTC}	Time for V_{LZTC} to Discharge to Fault Threshold when Terminated with $C = 0.1\ \mu\text{F}$	msec		2	
V_{LZCSE}	LZCSE Reference Voltage	V		0.4	
V_{LZBTP}	Bandgap Test Point Reference Voltage	V		2.3	
V_{LZMDF}	Laser Monitor Diode Feedback Voltage	V		1.85	
A_{DCOA}	Laser Driver DC Operational Amplifier Gain, Unloaded, see Figure 3	dB		35	
f_{-3dB}	Laser Driver DC Operational Amplifier Bandwidth	MHz		300	
V_{LZDC_OP}	Recommended LZDC Operating Range, Laser Diode DC Bias Control	V	$V_{CC} - 1.8$		$V_{CC} - 0.75$
V_{LZDC_DCL}	LZDC Laser DC Bias Low Voltage Setting	V			$V_{CC} - 2.0$
V_{LZDC_DCH}	LZDC Laser DC Bias High Voltage Setting	V	$V_{CC} - 0.6$		
I_{LZDC_L}	LZDC Load Current, over V_{LZDC_OP}	mA	1.3		
Z_{LZDC_ACO}	LZDC AC Output Impedance	Ω		400	
Z_{LZMDF_ACI}	LZMDF AC Input Impedance	Ω		10,000	
I_{LZMDF}	LZMDF Input Current	μA		6	15

HDMP-1512 (Tx)

Timing Characteristics

$T_C = 0^\circ\text{C}$ to $+85^\circ\text{C}$, $V_{CC} = 4.5\text{ V}$ to 5.5 V , PPSEL = 0, SPDSEL = 1

Symbol	Parameter	Units	Min.	Typ.	Max.
t_s	Setup Time	nsec			2
t_h	Hold Time	nsec			2.3
t_{txlat}	Transmit Latency ^[1]	nsec		18	

Note:

1. The Transmitter Latency is defined as the delay time from when a valid data word at TX[00:19] is clocked into the transmitter (triggered by the rising edge of TBC during the time t_h) and when the first serial bit is transmitted on pins \pm SO (defined by the leading edge of the first bit transmitted).

HDMP-1514 (Rx)

Timing Characteristics

$T_C = 0^\circ\text{C}$ to $+85^\circ\text{C}$, $V_{CC} = 4.5\text{ V}$ to 5.5 V , PPSEL = 0, SPDSEL = 1

Symbol	Parameter	Units	Min.	Typ.	Max.
t_{flock}	Frequency Lock Rate, Loop Filter Capacitor = $0.01\ \mu\text{F}$	kHz/ μsec		100	
BLT	Bit Lock Time	bit times			2500
t_s	Setup Time	nsec	2.5		
t_h	Hold Time	nsec	6.0		
t_s'	Setup Time for Data Rx[10:19] in Ping-Pong Mode	nsec		6	
t_h'	Hold Time for Data Rx[10:19] in Ping-Pong Mode	nsec		8	
t_{rxlat}	Receive Latency ^[1]	nsec		38	

Note:

1. The Receiver Latency is defined as the delay time from receiving the first serial bit of a parallel data word (defined by the rising edge of the first bit received at pins \pm DI), and when that word is first clocked out at RX[00:19] (as defined by the falling edge of RBC0 or RBC1, following time t_s).

HDMP-1512 (Tx), HDMP-1514 (Rx)

Thermal Characteristics, $T_C = 0^\circ\text{C}$ to $+85^\circ\text{C}$

Symbol	Parameter	Units	Typ.
$P_{D, Tx}$	Transmitter Power Dissipation, $V_{CC} = +5\text{ V}$	Watt	1.6
$P_{D, Rx}$	Receiver Power Dissipation, $V_{CC} = +5\text{ V}$	Watt	2
Θ_{jc}	Thermal Resistance, Junction to Case	$^\circ\text{C}/\text{Watt}$	12

I/O Type Definitions

I/O Type	Definition
I-TTL	Input TTL. Floats high when left open.
O-TTL	Output TTL.
O-BLL	50 Ω buffer line logic output driver. Should be ac coupled to drive 50 Ω loads. It can also drive the I-H50 inputs through differential direct coupling. Note: all unused outputs should be terminated with 50 Ω to V_{CC} .
I-H50	Input with internal 50 Ω terminations. Input is diode level shifted so that it can swing around V_{CC} . Can be driven with single-ended or differential, ac coupled configuration. To avoid permanent damage, these inputs should not be connected to ground.
C	External circuit node.
S	Power supply or ground.

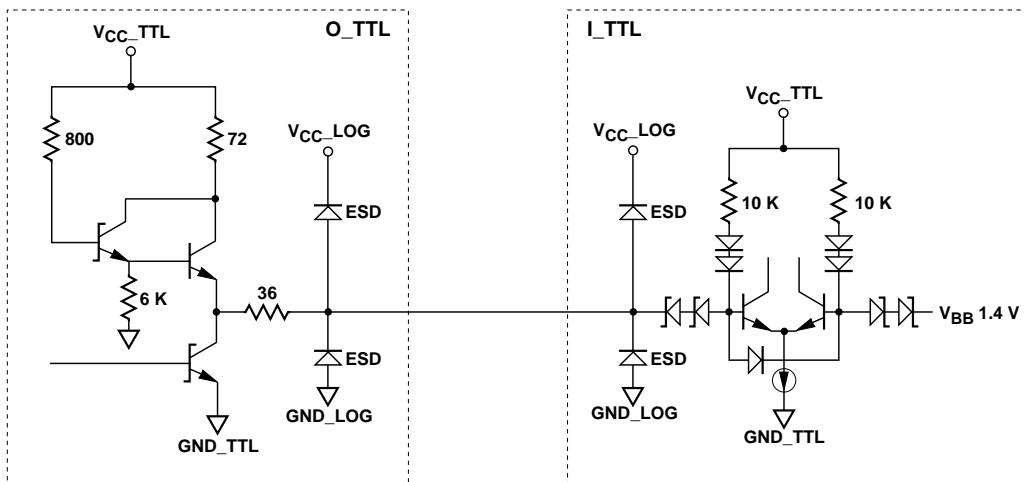

Figure 9. O-TTL and I-TTL Simplified Circuit Schematic.

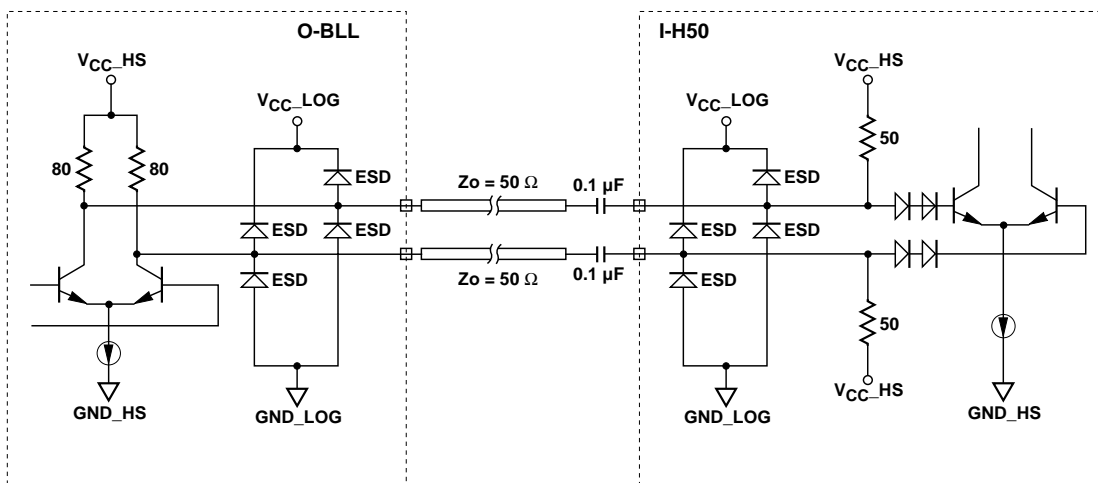

Figure 10. O-BLL and I-H50 Simplified Circuit Schematics. (Note: I-H50 Inputs Should Never Be Connected to Ground as Permanent Damage to the Device May Result.)

HDMP-1512 (Tx) Pin Assignments

Pin	Name	Pin	Name	Pin	Name	Pin	Name
01	CAP1A	21	LZDC	41	VCC_TTL	61	TX[18]
02	CAP1B	22	LZMDF	42	VCC_TTL	62	TX[19]
03	GND_A	23	VCC_LZ	43	TX[00]	63	VCC_TTL
04	GND_A	24	VCC_LZ	44	TX[01]	64	VCC_TTL
05	+SO	25	GND_LZ	45	TX[02]	65	GND_TTL
06	-SO	26	GND_LZ	46	TX[03]	66	GND_TTL
07	VCC_HS1	27	LZTC	47	TX[04]	67	SPDSEL
08	+LOUT	28	LZBTP	48	TX[05]	68	VCC_LOG
09	-LOUT	29	FAULT	49	TX[06]	69	-ECLKSEL
10	GND_LZHS	30	-LZON	50	TX[07]	70	GND_LOG
11	+SI	31	GND_LOG	51	TX[08]	71	EWRAP
12	-SI	32	-COMGEN	52	TX[09]	72	VCC_LOG
13	VCC_HS2	33	VCC_LOG	53	TX[10]	73	TBC
14	LZCSE	34	PPSEL	54	TX[11]	74	GND_LOG
15	VCC_LZBG	35	GND_LOG	55	TX[12]	75	TS2
16	VCC_LZ1	36	LZPWRON	56	TX[13]	76	TS1
17	VCC_LZAC	37	VCC_LOG	57	TX[14]	77	VCC_A
18	GND_LZHS	38	NC	58	TX[15]	78	VCC_A
19	+LZOUT	39	GND_TTL	59	TX[16]	79	CAP0A
20	-LZOUT	40	GND_TTL	60	TX[17]	80	CAP0B

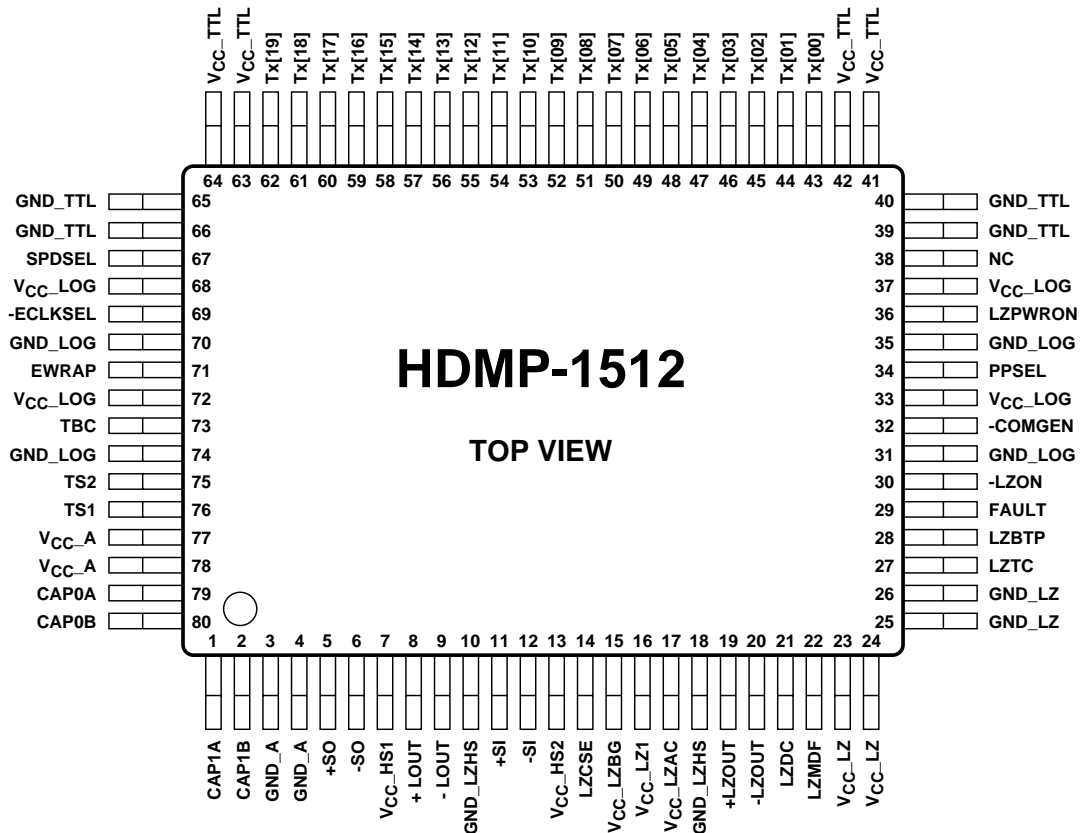

Figure 11. HDMP-1512 (Tx) Package Layout, Top View.

HDMP-1512 (Tx), Signal Definitions

Symbol	Signal Name	I/O	Logic Type	Description
CAPO[A:B]	Loop Filter Capacitor Pins [79,80]	C		PLL filter capacitor should be connected from pins 79 and 80 to pins 1 and 2 (typical value = 0.01 μ F). See Figures 18, 19, 20, and 21.
CAP1[A:B]	Loop Filter Capacitor Pins [1,2]	C		PLL filter capacitor should be connected from pins 79 and 80 to pins 1 and 2 (typical value = 0.01 μ F). See Figures 18, 19, 20, and 21.
-COMGEN	Comma Generate Pin [32]	Input	TTL	An active low input, causes the transmitter to internally generate the positive disparity K28.5 byte (0011111010) for transmission.
-ECLKSEL	External Clock Select Pin [69]	Input	TTL	An active low input, selects the TBC inputs to be used as the serial clock, bypassing the PLL. Used mainly for testing.
EWRAP	Enable Wrap Pin [71]	Input	TTL	Works in conjunction with TS1 and TS2 to specify input and output ports.
FAULT	Laser Fault Indicator Pin [29]	Output	TTL	Indicates the laser output level has moved outside of the window detector set boundary and the laser test capacitor (LZTC) has discharged to a fault level. This output is reset by the -LZON pin.
GND_A	Analog Ground Pins [3,4]	S		Normally 0 volts. Used to provide a clean ground plane for the critical PLL and high speed analog cells.
GND_LOG	Logic Ground Pins [31,35,70,74]	S		Normally 0 volts. Used for all internal PECL logic. Should be completely isolated from the noisy TTL ground.
GND_LZ	Laser Ground Pins [25,26]	S		Normally 0 volts. Used for all laser circuitry.
GND_LZHS	Laser High Speed Ground Pins [10,18]	S		Normally 0 volts.
GND_TTL	TTL Ground Pins [39,40,65,66]	S		Normally 0 volts. Used for all TTL I/O buffer cells.
\pm LOUT	Local Serial Data Pins [8,9]	Output	BLL	High speed data port, typically connected to the \pm LIN port on the local receiver during serial wrap mode.
LZBTP	Laser Bandgap Test Point Pin [28]	C		This pin is internally set to 2.3 VDC and normally should connect to one terminal of the laser DC bias resistor (pot1 Figure 3).
LZCSE	Laser Current Source Emitter Pin [14]	C		Used to set the bias current of the AC laser driver. Typical use is shown in Figure 3 where pot2 is used to set the laser modulation depth.
LZDC	Laser DC Drive Pin [21]	C		Used to control the laser diode DC bias (Figure 3).
\pm LZOUT	Laser Driver Serial Output Pins [19,20]	C		AC driver to the laser diode. The outputs should be AC coupled to the laser bias circuit.
LZMDF	Laser Monitor Diode Feedback Pin [22]	C		Connects to the laser monitor diode and one terminal of the laser DC bias resistor (pot1). Under normal operating conditions, the voltage on this pin will be 1.85 V.
-LZON	Laser Control and Reset Pin [30]	Input	TTL	The laser diode is turned on (active low) or off (high) with this input. In the off state the capacitor on pin LZTC charges, resetting the window detector (Figure 3).

HDMP-1512 (Tx), Signal Definitions (cont'd.)

Symbol	Signal Name	I/O	Logic Type	Description
LZPWRON	Laser Power On Pin [36]	Input	TTL	Used in conjunction with the dual loss of light detectors and the OFC circuit to assure the system is ready to power up the laser.
LZTC	Laser Timing Cap Pin [27]	C		The capacitor connected to this pin will be pre-charged at power-up. During operation, if the window detector detects the laser bias to be out of range, this capacitor will begin to discharge. If the condition lasts long enough, the capacitor voltage will fall below the fault level and the FAULT pin will go high. Nominal fault level is <1.0 volts.
PPSEL	Ping-Pong Select Pin [34]	Input	TTL	A high signal applied to this pin causes the transmitter to clock the data in by alternating between data byte 0 on the rising edge of TBC and data byte 1 one half clock cycle later. When this pin is low, both data bytes are clocked in on the rising edge of TBC.
± SI	Laser External Serial Input Pins [11,12]	Input	H50	The signal on this pin is input directly to the internal laser driver circuitry or the LOUT pin. This input is selected with the proper setting of TS1, TS2 and EWRAP (see Input/Output Select table).
± SO	Cable Serial Data Output Pins [5,6]	Output	BLL	High speed data output port. See Input/Output Select table to enable this output.
SPDSEL	Serial Speed Select Pin [67]	Input	TTL	Sets the chip to operate at the serial data rate of 1062.5 Mbaud (high) or 531.25 Mbaud (low).
TBC	Transmit Byte Clock Pin [73]	Input	TTL	A 53.125 Mhz clock supplied by the host system. This reference clock is multiplied by 10 or 20 to generate the serial bit clock (531.25 MHz or 1062.5 MHz).
TS[1:2]	Input/Output Select Input Pins [75,76]	Input	TTL	TS1 and TS2 work in conjunction with EWRAP to specify active input and output ports.
TX[00:19]	Data Inputs Pins [43:62]	Input	TTL	Two, 10 bit, pre-encoded data bytes. Byte 0 is comprised of bits TX[00:09] and byte 1 is comprised of bits TX[10:19]. The serialized bit stream is transmitted TX[00] through TX[09] then TX[10] through TX[19].
VCC_A	Analog Supply Pins [77, 78]	S		Provides a clean power source for the critical PLL and high speed analog cells. Normally +5.0 volts.
VCC_HS1	High Speed Supply 1 Pin [7]	S		Provides a clean power source for the high speed cells. Noise on this line should be minimized for best performance. Normally +5.0 volts.
VCC_HS2	High Speed Supply 2 Pin [13]	S		Provides a clean power source for the high speed cells. Noise on this line should be minimized for best performance. Normally +5.0 volts.
VCC_LOG	Logic Power Supply Pins [33,37,68,72]	S		Used for all internal PECL logic. Isolate from the noisy TTL supply. Normally +5.0 volts.
VCC_LZ	Laser Power Supply Pins [23,24]	S		Power supply for low speed laser driver circuitry. Normally +5.0 volts.
VCC_LZ1	Laser Power Supply Pin [16]	S		Power supply for all laser driver AC circuitry. Normally +5.0 volts.

HDMP-1512 (Tx), Signal Definitions (cont'd.)

Symbol	Signal Name	I/O	Logic Type	Description
VCC_LZAC	Laser Power Supply Pin [17]	S		Power supply for all high speed laser driver circuitry. Normally +5.0 volts.
VCC_LZBG	Laser Power Supply Pins [15]	S		Power supply for low speed laser driver circuitry. Normally +5.0 volts.
VCC_TTL	TTL Power Supply Pins [41,42,63,64]	S		Power supply for all TTL buffer I/O cells. Normally +5.0 volts.
NC	Pin [38]			No connection.

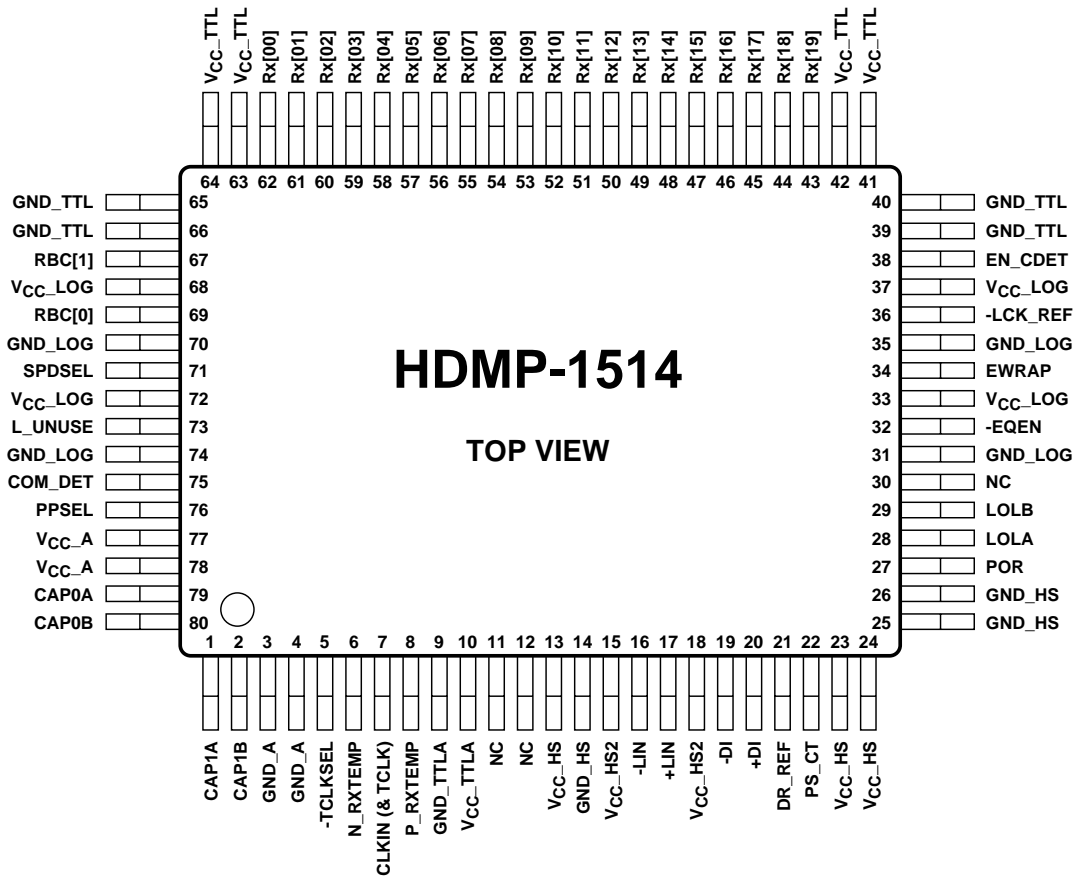

Figure 12. HDMP-1514 (Rx) Package Layout.

HDMP-1514 (Rx) Pin Assignments

Pin	Name	Pin	Name	Pin	Name	Pin	Name
01	CAP1A	21	DR_REF	41	VCC_TTL	61	RX[01]
02	CAP1B	22	PS_CT	42	VCC_TTL	62	RX[00]
03	GND_A	23	VCC_HS	43	RX[19]	63	VCC_TTL
04	GND_A	24	VCC_HS	44	RX[18]	64	VCC_TTL
05	-TCLKSEL	25	GND_HS	45	RX[17]	65	GND_TTL
06	N_RXTEMP	26	GND_HS	46	RX[16]	66	GND_TTL
07	CLKIN (TCLK)	27	-POR	47	RX[15]	67	RBC[1]
08	P_RXTEMP	28	LOLA	48	RX[14]	68	VCC_LOG
09	GND_TTLA	29	LOLB	49	RX[13]	69	RBC[0]
10	VCC_TTLA	30	NC	50	RX[12]	70	GND_LOG
11	NC	31	GND_LOG	51	RX[11]	71	SPDSEL
12	NC	32	-EQEN	52	RX[10]	72	VCC_LOG
13	VCC_HS	33	VCC_LOG	53	RX[09]	73	L_UNUSE
14	GND_HS	34	EWRAP	54	RX[08]	74	GND_LOG
15	VCC_HS2	35	GND_LOG	55	RX[07]	75	COM_DET
16	-LIN	36	-LCK_REF	56	RX[06]	76	PPSEL
17	+LIN	37	VCC_LOG	57	RX[05]	77	VCC_A
18	VCC_HS2	38	EN_CDET	58	RX[04]	78	VCC_A
19	-DI	39	GND_TTL	59	RX[03]	79	CAP0A
20	+DI	40	GND_TTL	60	RX[02]	80	CAP0B

HDMP-1514 (Rx), Signal Definitions

Symbol	Signal Name	I/O	Logic Type	Description
CAP0[A:B]	Loop Filter Capacitor Pins [79,80]	C		PLL filter capacitor should be connected from pins 79 and 80 to pins 1 and 2 (typical value = 0.01 μ F). See Figures 18, 19, 20, and 21.
CAP1[A:B]	Loop Filter Capacitor Pins [1,2]	C		PLL filter capacitor should be connected from pins 79 and 80 to pins 1 and 2 (typical value = 0.01 μ F). See Figures 18, 19, 20, and 21.
CLKIN (TCLK)	Receive Reference Clock Pin [7]	Input	TTL	A 53.125 MHz clock supplied by the host system. CLKIN is used by the internal PLL to acquire frequency lock when the -LCKREF input is brought low.
COM_DET	Comma Detect Pin [75]	Output	TTL	Indicates the detection of a comma character (K28.5 of positive disparity). It is only active when EN_CDET is high.
\pm DI	Serial Data Inputs Pins [19,20]	Input	H50	High speed serial data inputs, selected when EWRAP is set low. An optional cable equalizer may also be enabled, see EQEN.

HDMP-1514 (Rx), Signal Definitions (cont'd.)

Symbol	Signal Name	I/O	Logic Type	Description
DR_REF	Receiver Reference Pin [21]	C		This node is used to set the peak-to-peak signal level of the loss of light detection circuitry.
EN_CDET	Enable Comma Detect Pin [38]	Input	TTL	When high, the receiver will reset internal clocks and registers when an incoming comma character (K28.5) of positive disparity (001111xxx) is detected. When low, clocks and registers will not reset and the comma detect output is disabled. Comma detect is also disabled whenever -LCK_REF is set low.
-EQEN	Equalizer Enable Input Pin [32]	Input	TTL	When set low, the internal cable equalizer amplifier on the \pm DI lines is enabled.
EWRAP	Enable Wrap Pin [71]	Input	TTL	When set high, the high speed data is taken from the \pm LIN port, enabling the data input from the local transmitter. When this input is set low, the high speed input is taken from the \pm DI lines.
GND_A	Analog Ground Pins [3,4]	S		Normally 0 volts. Used to provide a clean ground plane for the critical PLL and high speed analog cells.
GND_HS	High Speed Ground Pins [14,25,26]	S		Normally 0 volts.
GND_LOG	Logic Ground Pins[31,35,70,74]	S		Normally 0 volts. Used for all internal PECL logic. Should be completely isolated from the noisy TTL ground.
GND_TTL	TTL Ground Pins [39,40,65,66]	S		Normally 0 volts. Used for all TTL I/O buffer cells.
GND_TTLA	TTL Ground Pin [9]	S		Normally 0 volts.
-LCK_REF	Lock to Reference Pin [36]	Input	TTL	A low input causes the internal PLL to acquire frequency lock on the external reference signal applied at CLKIN. To assure lock, this pin should be held low for at least 500 μ sec and held high at all other times. A low input disables the comma detect function.
L_UNUSE	Link Unusable Pin [73]	Input	TTL	Typically supplied from open fiber control circuitry. Used in conjunction with EWRAP and -LCK_REF to keep the internal Vco near operational frequency, optimizing frequency lock times.
\pm LIN	Local Serial Data Pins [16,17]	Input	H50	High speed data port, typically connected to the \pm LOUT port on the local transmitter when in serial wrap mode.
LOLA	Loss of Light Signal Pin [28]	Output	TTL	A high signal on this pin indicates the amplitude of the input serial data has fallen below a preset level (see DR_REF) or no transitions have been detected within 4 cycles of TBC.
LOLB	Loss of Light Signal Pin [29]	Output	TTL	A high signal on this pin indicates the amplitude of the input serial data has fallen below a preset level (see DR_REF) or no transitions have been detected within 4 cycles of TBC.
N_RXTEMP	Temperature Monitor Pin [6]	C		Used in conjunction with pin 8 (P_RXTEMP) to monitor the on-chip temperature diode (Cathode.)
P_RXTEMP	Temperature Monitor Pin [8]	C		Used in conjunction with pin 6 (N_RXTEMP) to monitor the on-chip temperature diode (Anode.)
-POR	Power on Reset Pin [27]	Output	TTL	Active low output. Monitors the power supply voltage on startup to assure V _{CC} is at the proper DC level.

HDMP-1514 (Rx), Signal Definitions (cont'd.)

Symbol	Signal Name	I/O	Logic Type	Description
PPSEL	Ping-Pong Select Pin [76]	Input	TTL	A high input instructs the receiver to clock the data out in ping-pong mode. Byte 0 will be clocked out on the falling edge of RBC0 and byte 1 will be clocked out on the falling edge of RBC1. A low input instructs the receiver to clock both data bytes out on the falling edge of RBC0.
PS_CT	Power Supply Timing Cap Pin [22]	C		Pin for connecting the timing capacitor for the power supervisor circuit.
RBC[0:1]	Receive Byte Clocks Pin [67, 69]	Output	TTL	Two clocks, 180° out of phase, generated from the recovered data. Used to clock out the two 10 bit data bytes.
RX[00:19]	Data Outputs Pins [43, 62]	Output	TTL	Two, 10 bit, bytes. Byte 0 is comprised of bits RX[00:09] and byte 1 is comprised of bits RX[10:19]. The serialized bit stream is received TX[00] through TX[09] then TX[10] through TX[19].
SPDSEL	Serial Speed Select Pin [71]	Input	TTL	Sets the chip to operate at the serial data rate of 1062.5 Mbaud (high) or 531.25 Mbaud (low).
-TCLKSEL	Test Clock Select Pin [5]	Input	TTL	An applied low selects CLKIN as the serial/bit-rate clock and bypasses the internal PLL. Used for testing only.
VCC_A	Analog Supply Pins [77, 78]	S		Provides a clean power source for the critical PLL and high speed analog cells. Normally +5.0 volts.
VCC_HS1	High Speed Supply Pins [13,23,24]	S		Provides a clean power source for the high speed receiver cell I-H50. Noise on this line should be minimized for best performance. Normally +5.0 volts.
VCC_HS2	High Speed Supply 2 Pins [15,18]	S		Provides a clean power source for the high speed receiver cell I-H50. Noise on this line should be minimized for best performance. Normally +5.0 volts.
VCC_LOG	Logic Power Supply Pins [33,37,68,72]	S		Used for all internal PECL logic. Isolate from the noisy TTL supply. Normally +5.0 volts.
VCC_TTL	TTL Power Supply Pins [41,42,63,64]	S		Power supply for all TTL buffer I/O cells. Normally +5.0 volts.
VCC_TTLA	TTL Power Supply Pin [10]	S		Power supply for all TTL I/O buffer cells. Normally +5.0 volts.
NC	Pins [11,12,30]			No connection.

Package Description and Assembly Recommendations

The HDMP-1512 and HDMP-1514 are available in the industry standard M-Quad 80 lead package. The outline dimensions conform to JEDEC plastic QFP specifications and are shown in Figure 13. The package material is aluminum. To facilitate surface mounting, the leads have been formed into a “GullWing” configuration. We recommend keeping the package temperature, T_C , below 85°C. Forced air cooling may be required.

M-Quad 80 Package Specifications

Item	Specification
Package Material	Aluminum
Lead Finish Material	85/15 Sn/Pb
Lead Finish Thickness	300-600 μ inches
Lead Coplanarity	0.004 inches maximum

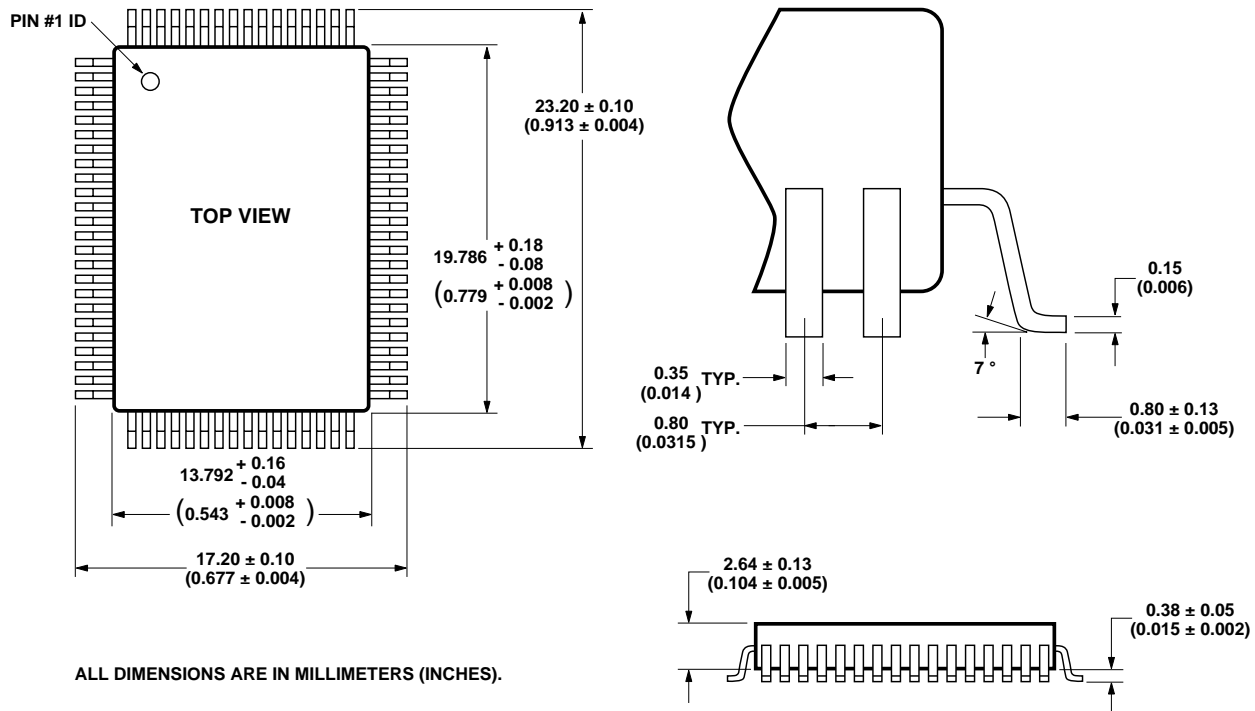

Figure 13. HDMP-1512 and HDMP-1514 Package Outline.

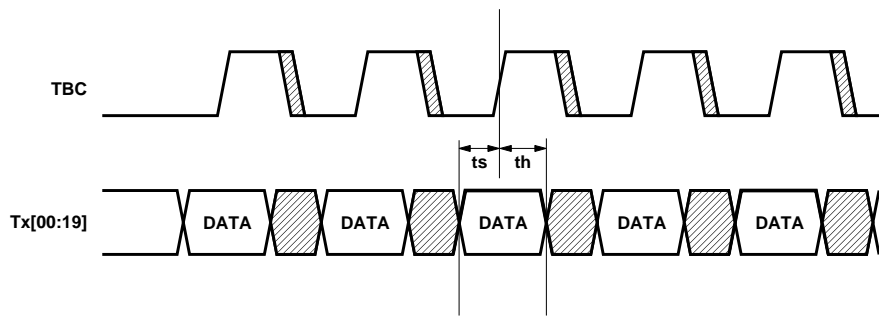

Figure 14. HDMP-1512 (Transmitter) Timing Diagram, with PPSEL = 0.

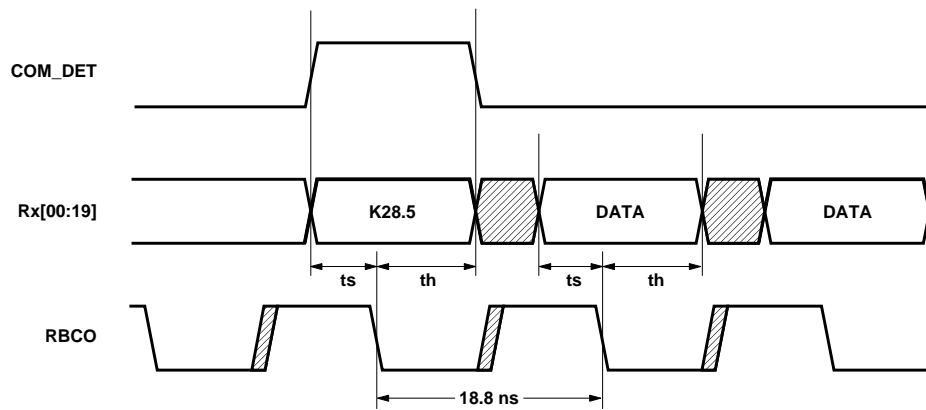

Figure 15. HDMP-1514 (Receiver) Timing Diagram, with PPSEL = 0.

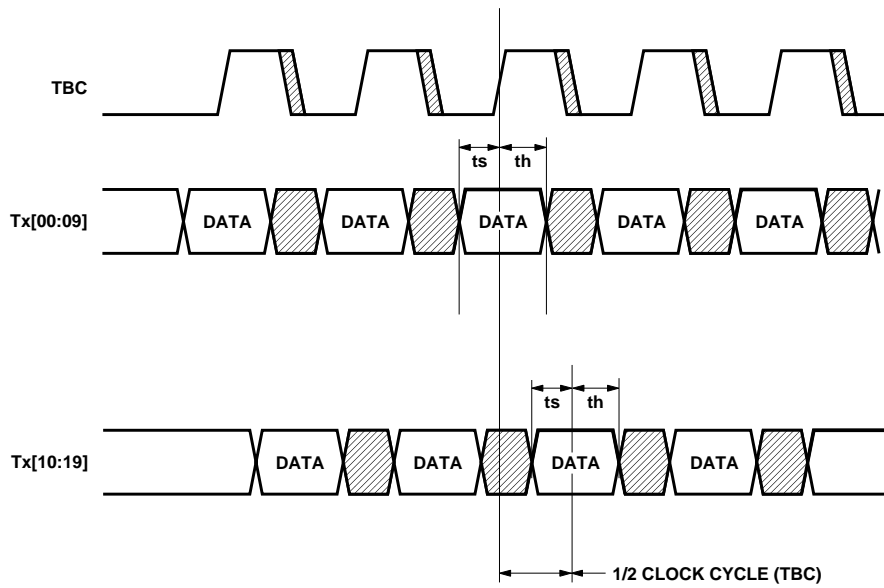

Figure 16. HDMP-1512 (Transmitter) Timing Diagram In Ping-Pong Mode, PPSEL = 1.

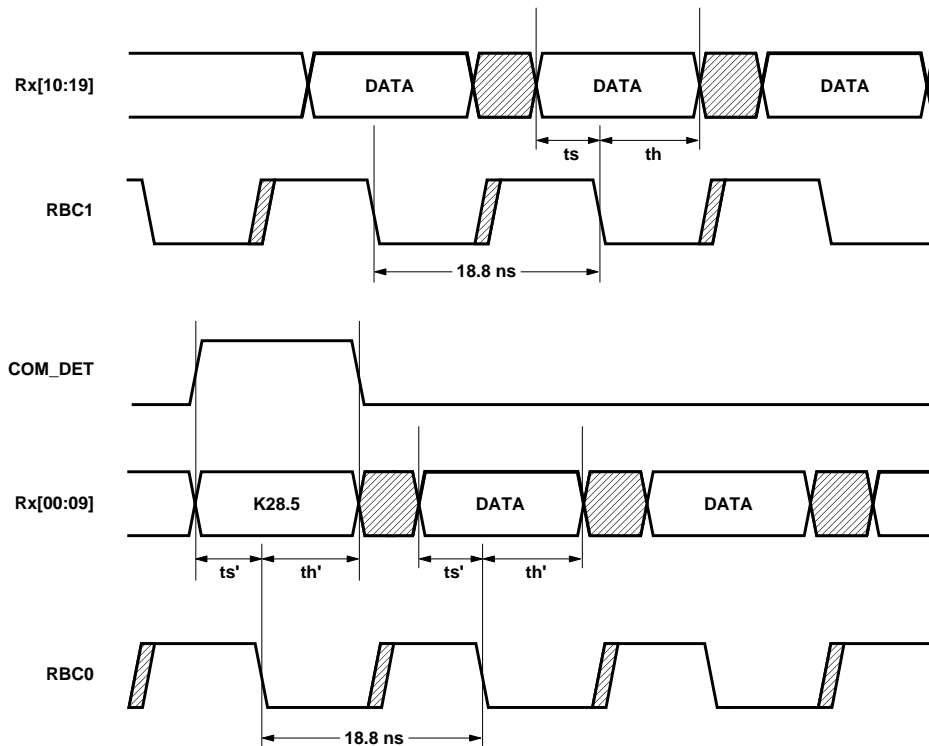

Figure 17. HDMP-1514 (Receiver) Timing Diagram in Ping-Pong Mode, with PPSEL = 1.

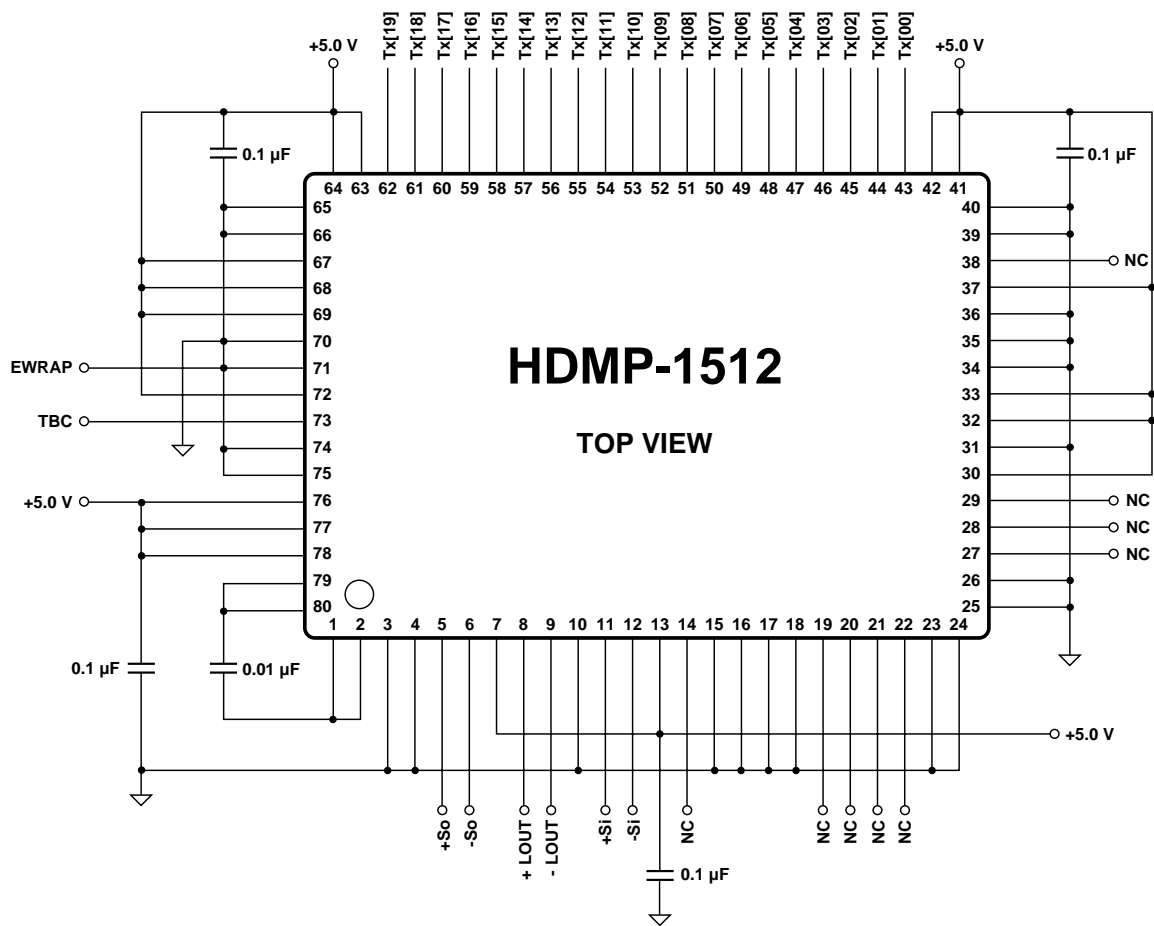

Figure 18. Typical Transmitter Pin Terminations for Applications Requiring High Speed Serial Copper Drivers (\pm So). Laser Driver Outputs are Disabled. For 1062.5 MBd Operation Only, SPDSEL (pin 67) Set High, Non Ping-Pong Mode (PPSEL = 0).

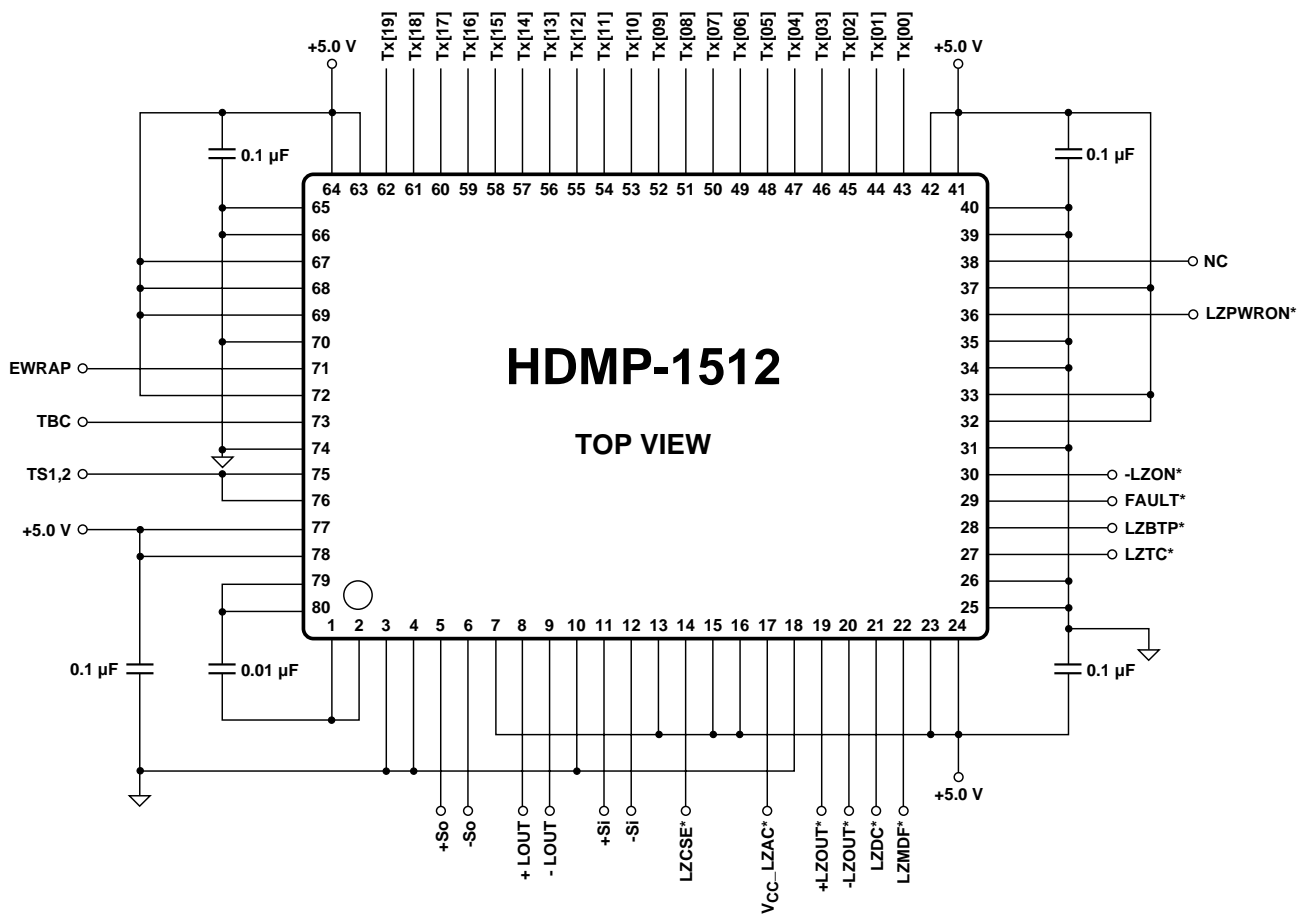

Figure 19. Typical Transmitter Pin Terminations for Applications Using the On-Chip Laser Driver. For Details of the Laser Driver Connections, Indicated by “*,” see Figure 3 on page 4. For 1062.5 MBd Operation Only, SPDSEL (pin 67) Set High, Non Ping-Pong Mode (PPSEL = 0).

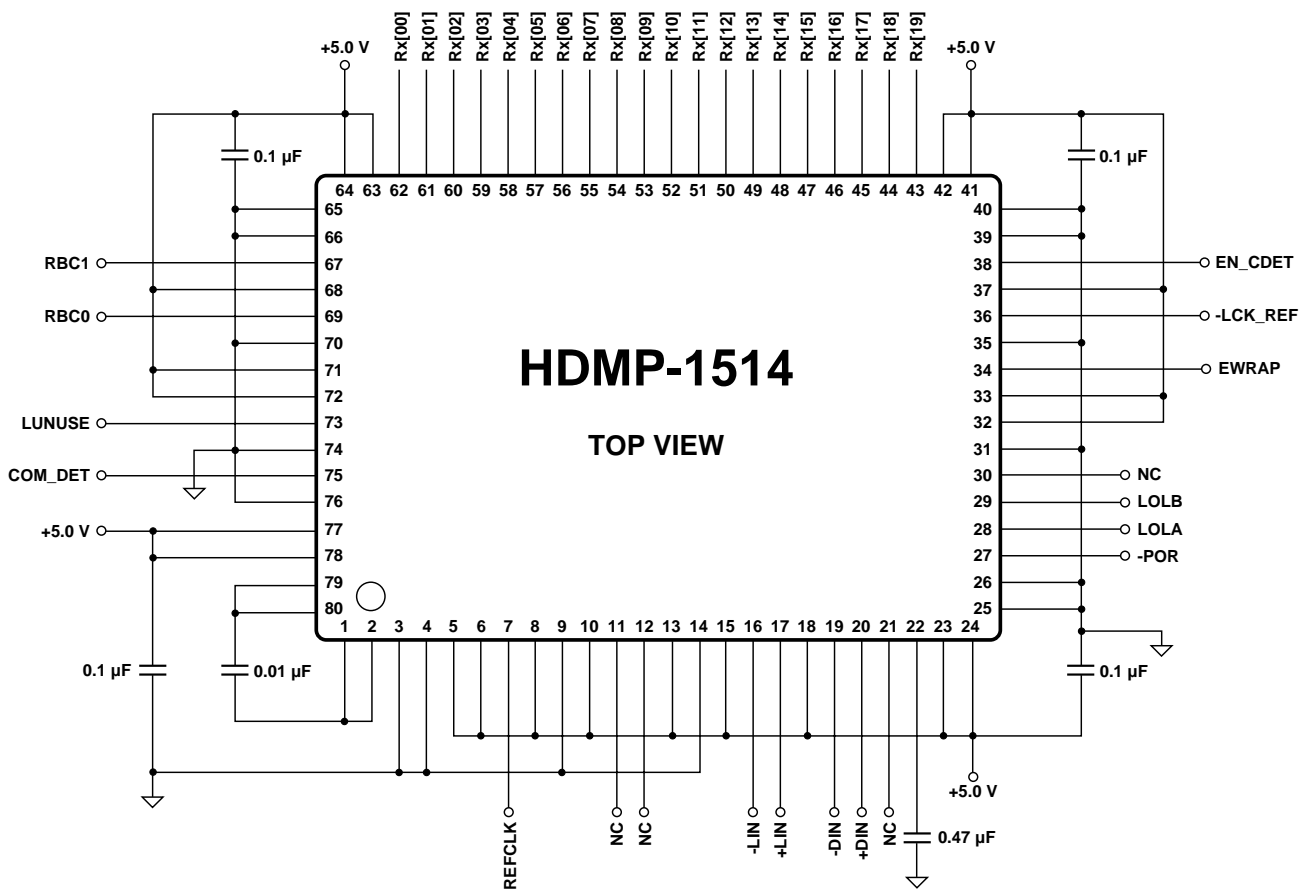

Figure 20. Typical Receiver Pin Terminations for Applications Using High Speed Serial Copper Links (\pm DIN). For 1062.5 MBd Operation Only, SPDSEL (pin 71) Set High, Non Ping-Pong Mode (PPSEL = 0).

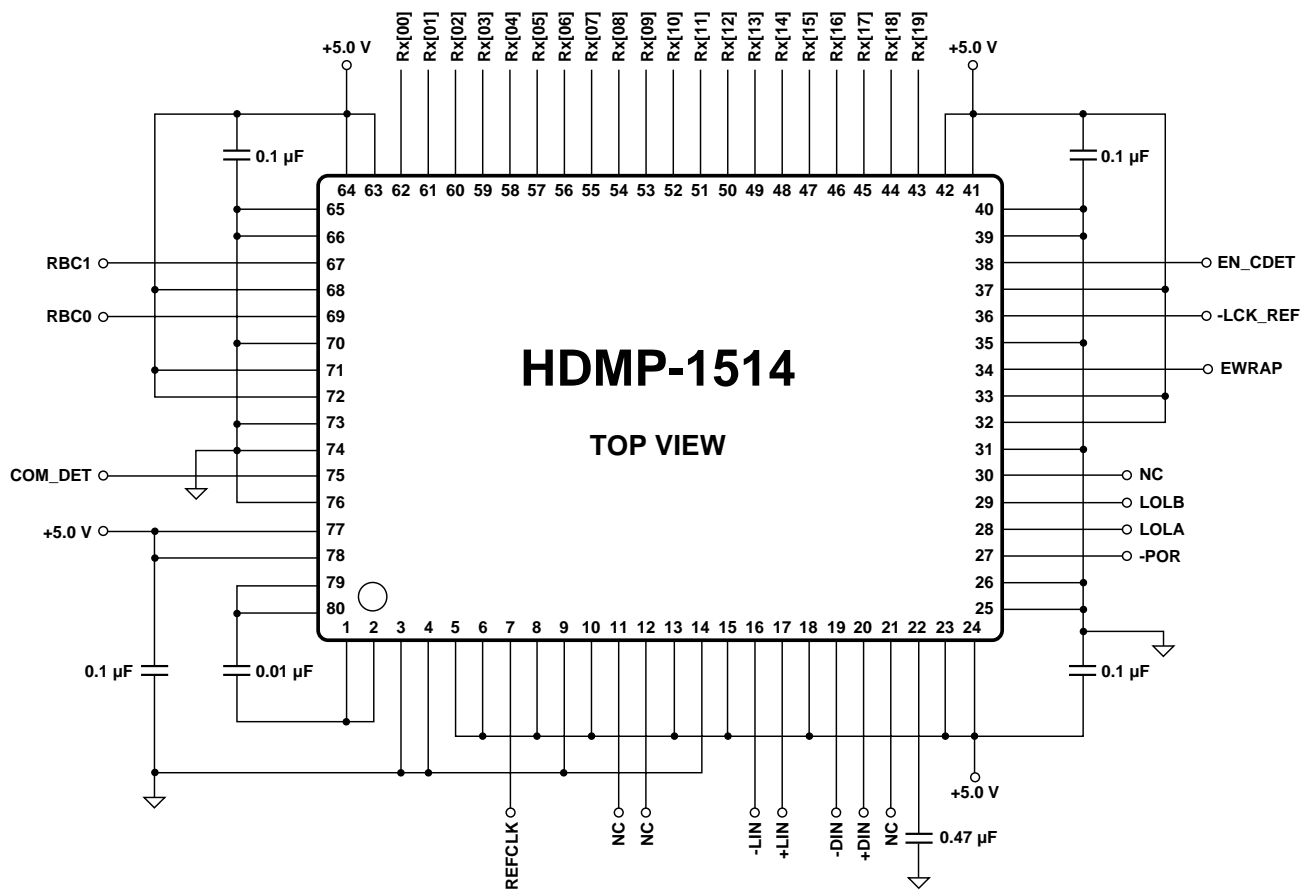

Figure 21. Typical Receiver Pin Terminations for Applications Using High Speed Fiber Links (\pm DIN). For 1062.5 MBd Operation Only, SPDSEL (pin 71) Set High, Non Ping-Pong Mode (PPSEL = 0).