

DATA SHEET

For a complete data sheet, please also download:

- The IC04 LOCMOS HE4000B Logic Family Specifications HEF, HEC
- The IC04 LOCMOS HE4000B Logic Package Outlines/Information HEF, HEC

HEF40192B

MSI

4-bit up/down decade counter

Product specification
File under Integrated Circuits, IC04

January 1995

4-bit up/down decade counter

HEF40192B MSI

DESCRIPTION

The HEF40192B is a 4-bit synchronous up/down decade counter. The counter has a count-up clock input (CP_U), a count-down clock input (CP_D), an asynchronous parallel load input (\overline{PL}), four parallel data inputs (P₀ to P₃), an asynchronous master reset input (MR), four counter outputs (O₀ to O₃), an active LOW terminal count-up (carry) output (\overline{TC}_U) and an active LOW terminal count-down (borrow) output (\overline{TC}_D).

The counter outputs change state on the LOW to HIGH transition of either clock input. However, for correct

counting, both clock inputs cannot be LOW simultaneously. The outputs \overline{TC}_U and \overline{TC}_D are normally HIGH. When the circuit has reached the maximum count state of '9', the next HIGH to LOW transition of CP_U will cause \overline{TC}_U to go LOW. \overline{TC}_U will stay LOW until CP_U goes HIGH again. Likewise, output \overline{TC}_D will go LOW when the circuit is in the zero state and CP_D goes LOW. When \overline{PL} is LOW, the information on P₀ to P₃ is asynchronously loaded into the counter. A HIGH on MR resets the counter independent of all other input conditions. The counter stages are of a static toggle type flip-flop.

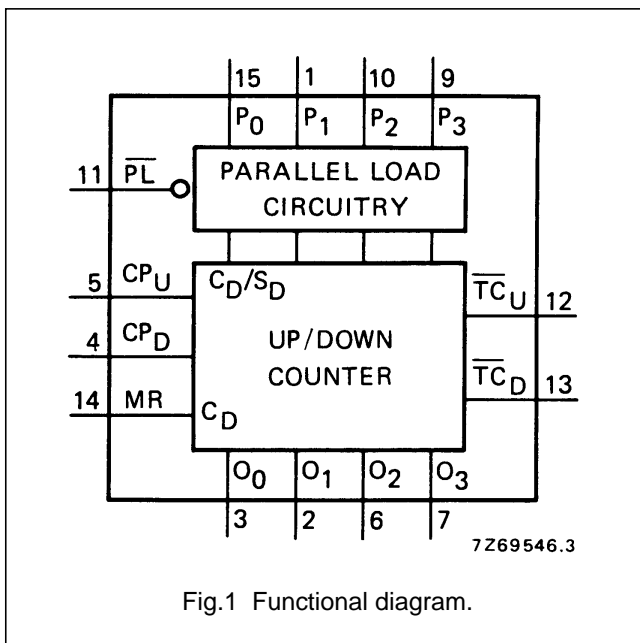

Fig.1 Functional diagram.

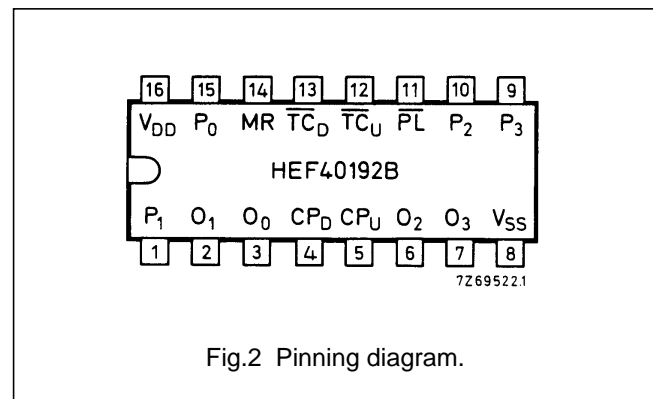

Fig.2 Pinning diagram.

PINNING

- \overline{PL} parallel load input (active LOW)
- P₀ to P₃ parallel data inputs
- CP_U count-up clock pulse input (LOW to HIGH, edge-triggered)
- CP_D count-down clock pulse input (LOW to HIGH, edge-triggered)
- MR master reset input (asynchronous)
- \overline{TC}_U buffered terminal count-up (carry) output (active LOW)
- \overline{TC}_D buffered terminal count-down (borrow) output (active LOW)
- O₀ to O₃ buffered counter outputs

- HEF40192BP(N): 16-lead DIL; plastic (SOT38-1)
- HEF40192BD(F): 16-lead DIL; ceramic (cerdip) (SOT74)
- HEF40192BT(D): 16-lead SO; plastic (SOT109-1)
- (): Package Designator North America

FAMILY DATA, I_{DD} LIMITS category MSI

See Family Specifications

4-bit up/down decade counter

HEF40192B
MSI

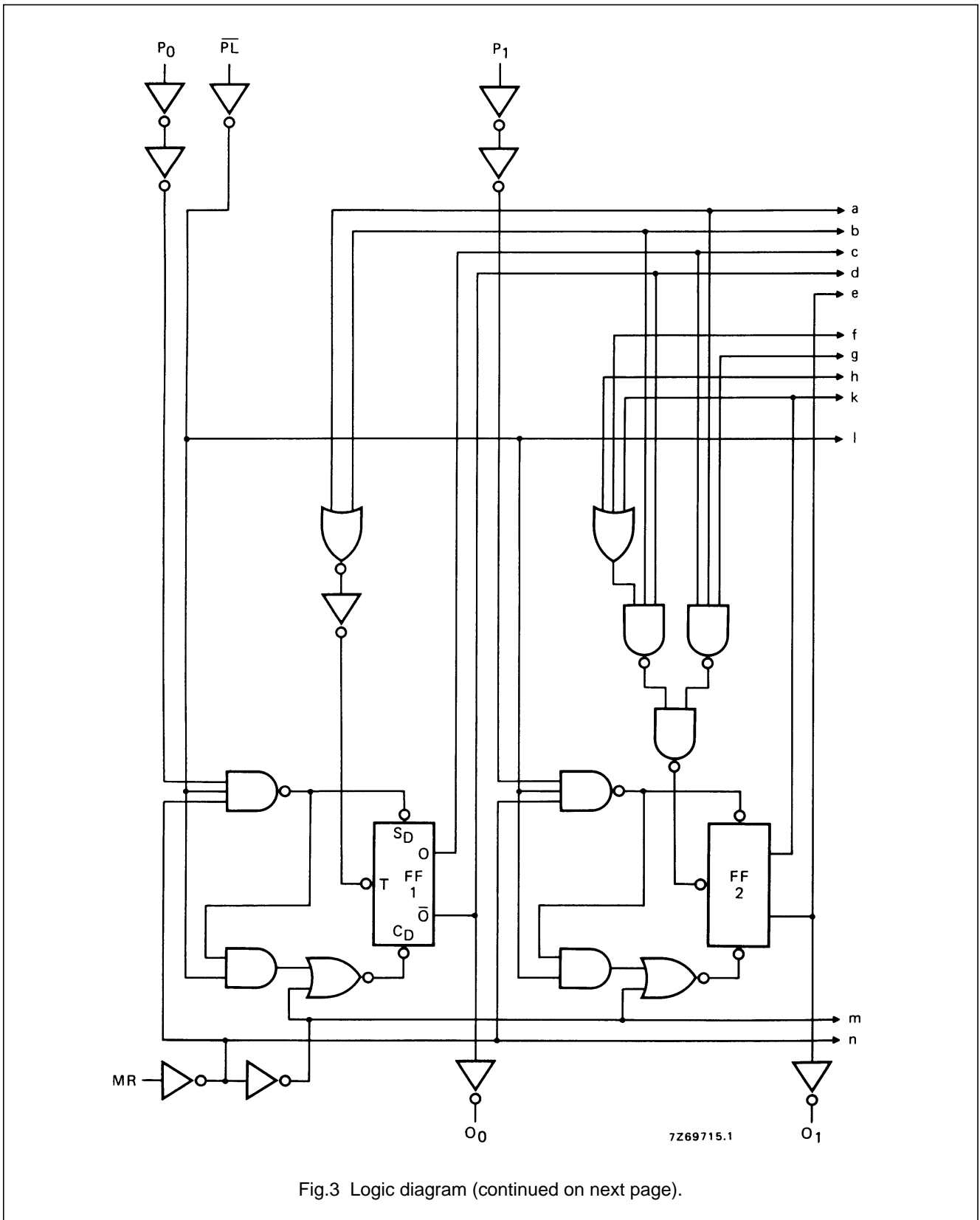

Fig.3 Logic diagram (continued on next page).

4-bit up/down decade counter

HEF40192B
MSI

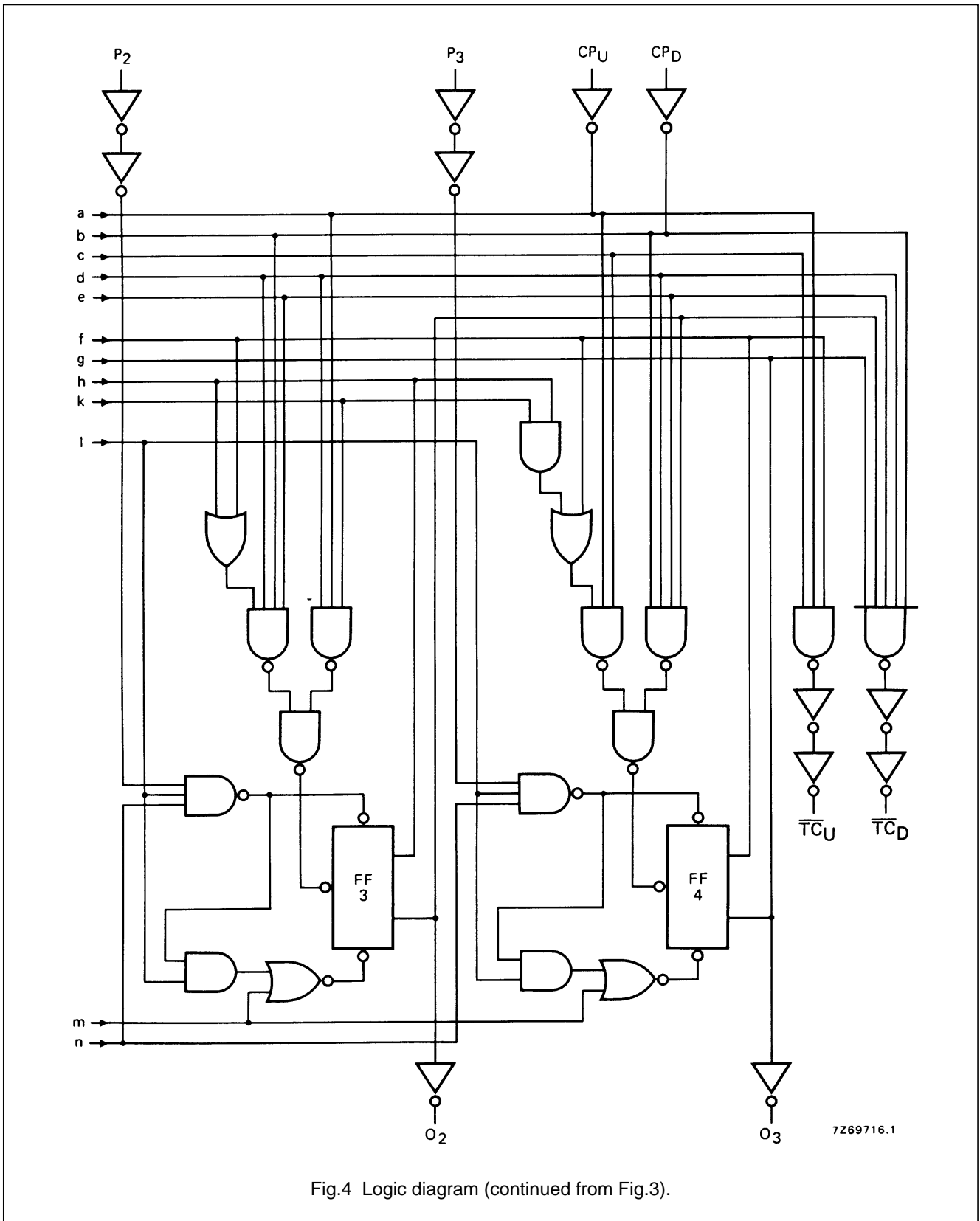



Fig.4 Logic diagram (continued from Fig.3).

4-bit up/down decade counter

HEF40192B
MSI

FUNCTION TABLE

MR	\overline{PL}	CP _U	CP _D	MODE
H	X	X	X	reset (asyn.)
L	L	X	X	parallel load
L	H		H	count-up
L	H	H		count-down

Notes

- H = HIGH state (the more positive voltage)
L = LOW state (the less positive voltage)
X = state is immaterial

 = positive-going transition

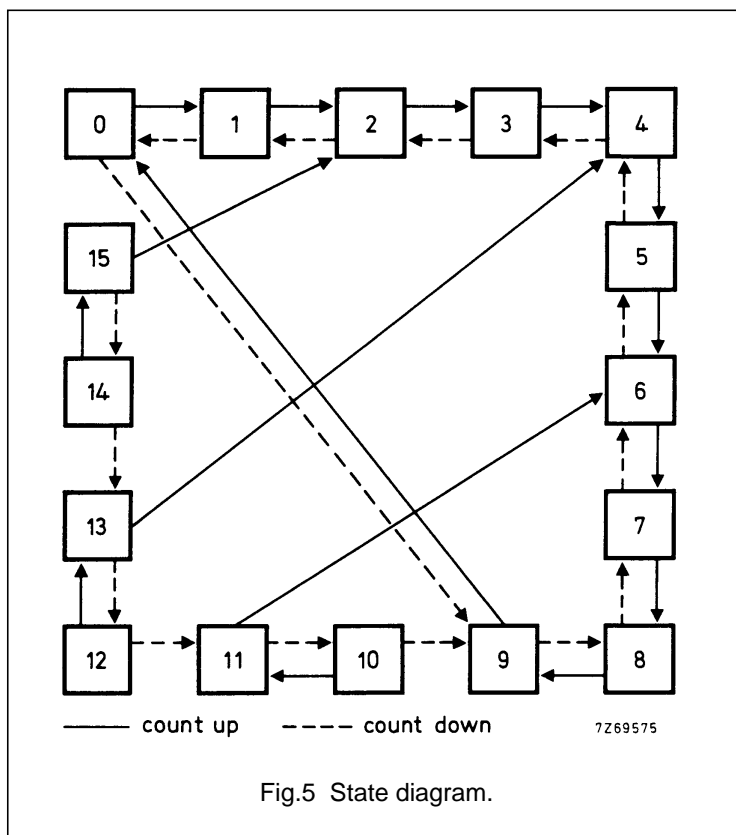

Logic equations for terminal count:

$$\overline{TC}_D = \overline{O_0 \cdot O_1 \cdot O_2 \cdot O_3 \cdot CP_D}$$

$$\overline{TC}_U = \overline{O_0 \cdot O_3 \cdot CP_U}$$

AC CHARACTERISTICS

V_{SS} = 0 V; T_{amb} = 25 °C; input transition times ≤ 20 ns

	V _{DD} V	TYPICAL FORMULA FOR P (μW)	
Dynamic power dissipation per package (P)	5 10 15	550 f _i + Σ(f _o C _L) × V _{DD} ² 2400 f _i + Σ(f _o C _L) × V _{DD} ² 6500 f _i + Σ(f _o C _L) × V _{DD} ²	where f _i = input freq. (MHz) f _o = output freq. (MHz) C _L = load capacitance (pF) Σ (f _o C _L) = sum of outputs V _{DD} = supply voltage (V)

4-bit up/down decade counter

HEF40192B
MSI

AC CHARACTERISTICS

 $V_{SS} = 0$ V; $T_{amb} = 25$ °C; $C_L = 50$ pF; input transition times ≤ 20 ns

	V_{DD} V	SYMBOL	MIN.	TYP.	MAX.	TYPICAL EXTRAPOLATION FORMULA		
Propagation delays $CP_U \rightarrow O_n$ HIGH to LOW	5	t_{PHL}		210	415	ns	$183 \text{ ns} + (0,55 \text{ ns/pF}) C_L$	
	10			85	165	ns	$74 \text{ ns} + (0,23 \text{ ns/pF}) C_L$	
	15			60	120	ns	$52 \text{ ns} + (0,16 \text{ ns/pF}) C_L$	
	LOW to HIGH	5	t_{PLH}		170	340	ns	$143 \text{ ns} + (0,55 \text{ ns/pF}) C_L$
		10			70	140	ns	$59 \text{ ns} + (0,23 \text{ ns/pF}) C_L$
		15			50	100	ns	$42 \text{ ns} + (0,16 \text{ ns/pF}) C_L$
$CP_D \rightarrow O_n$ HIGH to LOW	5	t_{PHL}		210	420	ns	$183 \text{ ns} + (0,55 \text{ ns/pF}) C_L$	
	10			85	170	ns	$74 \text{ ns} + (0,23 \text{ ns/pF}) C_L$	
	15			65	125	ns	$57 \text{ ns} + (0,16 \text{ ns/pF}) C_L$	
	LOW to HIGH	5	t_{PLH}		170	340	ns	$143 \text{ ns} + (0,55 \text{ ns/pF}) C_L$
		10			70	140	ns	$59 \text{ ns} + (0,23 \text{ ns/pF}) C_L$
		15			50	100	ns	$42 \text{ ns} + (0,16 \text{ ns/pF}) C_L$
$CP_U \rightarrow \overline{TC_U}$ HIGH to LOW	5	t_{PHL}		125	250	ns	$98 \text{ ns} + (0,55 \text{ ns/pF}) C_L$	
	10			50	100	ns	$39 \text{ ns} + (0,23 \text{ ns/pF}) C_L$	
	15			35	70	ns	$27 \text{ ns} + (0,16 \text{ ns/pF}) C_L$	
	LOW to HIGH	5	t_{PLH}		95	185	ns	$68 \text{ ns} + (0,55 \text{ ns/pF}) C_L$
		10			40	80	ns	$29 \text{ ns} + (0,23 \text{ ns/pF}) C_L$
		15			30	60	ns	$22 \text{ ns} + (0,16 \text{ ns/pF}) C_L$
$CP_D \rightarrow \overline{TC_D}$ HIGH to LOW	5	t_{PHL}		140	280	ns	$113 \text{ ns} + (0,55 \text{ ns/pF}) C_L$	
	10			55	110	ns	$44 \text{ ns} + (0,23 \text{ ns/pF}) C_L$	
	15			40	80	ns	$32 \text{ ns} + (0,16 \text{ ns/pF}) C_L$	
	LOW to HIGH	5	t_{PLH}		100	195	ns	$73 \text{ ns} + (0,55 \text{ ns/pF}) C_L$
		10			40	85	ns	$29 \text{ ns} + (0,23 \text{ ns/pF}) C_L$
		15			30	65	ns	$22 \text{ ns} + (0,16 \text{ ns/pF}) C_L$
$MR \rightarrow O_n$ HIGH to LOW	5	t_{PHL}		195	390	ns	$168 \text{ ns} + (0,55 \text{ ns/pF}) C_L$	
	10			80	160	ns	$69 \text{ ns} + (0,23 \text{ ns/pF}) C_L$	
	15			60	120	ns	$52 \text{ ns} + (0,16 \text{ ns/pF}) C_L$	
$MR \rightarrow \overline{TC_U}$ LOW to HIGH	5	t_{PLH}		145	285	ns	$118 \text{ ns} + (0,55 \text{ ns/pF}) C_L$	
	10			60	115	ns	$49 \text{ ns} + (0,23 \text{ ns/pF}) C_L$	
	15			45	90	ns	$37 \text{ ns} + (0,16 \text{ ns/pF}) C_L$	
$MR \rightarrow \overline{TC_D}$ HIGH to LOW	5	t_{PHL}		365	730	ns	$338 \text{ ns} + (0,55 \text{ ns/pF}) C_L$	
	10			130	265	ns	$119 \text{ ns} + (0,23 \text{ ns/pF}) C_L$	
	15			100	205	ns	$92 \text{ ns} + (0,16 \text{ ns/pF}) C_L$	
$\overline{PL} \rightarrow O_n$ HIGH to LOW	5	t_{PHL}		185	360	ns	$158 \text{ ns} + (0,55 \text{ ns/pF}) C_L$	
	10			75	150	ns	$64 \text{ ns} + (0,23 \text{ ns/pF}) C_L$	
	15			55	110	ns	$47 \text{ ns} + (0,16 \text{ ns/pF}) C_L$	

4-bit up/down decade counter

HEF40192B
MSI

	V _{DD} V	SYMBOL	MIN.	TYP.	MAX.	TYPICAL EXTRAPOLATION FORMULA	
LOW to HIGH	5	t _{PLH}		145	290	ns	118 ns + (0,55 ns/pF) C _L
	10			60	120	ns	49 ns + (0,23 ns/pF) C _L
	15			45	90	ns	37 ns + (0,16 ns/pF) C _L

AC CHARACTERISTICS

V_{SS} = 0 V; T_{amb} = 25 °C; C_L = 50 pF; input transition times ≤ 20 ns

	V _{DD} V	SYMBOL	MIN.	TYP.	MAX.	TYPICAL EXTRAPOLATION FORMULA	
Output transition times HIGH to LOW	5	t _{THL}		60	120	ns	10 ns + (1,0 ns/pF) C _L
	10			30	60	ns	9 ns + (0,42 ns/pF) C _L
	15			20	40	ns	6 ns + (0,28 ns/pF) C _L
LOW to HIGH	5	t _{TLH}		60	120	ns	10 ns + (1,0 ns/pF) C _L
	10			30	60	ns	9 ns + (0,42 ns/pF) C _L
	15			20	40	ns	6 ns + (0,28 ns/pF) C _L
Set-up time P _n → P _L	5	t _{su}	160	80		ns	see also waveforms Fig.6
	10		60	30		ns	
	15		50	25		ns	
Hold time P _n → P _L	5	t _{hold}	10	-70		ns	
	10		5	-25		ns	
	15		5	-20		ns	
Minimum CP _U or CP _D pulse width; LOW	5	t _{WCPL}	150	75		ns	
	10		50	25		ns	
	15		35	20		ns	
Minimum MR pulse width; HIGH	5	t _{WMRH}	180	90		ns	
	10		70	35		ns	
	15		60	30		ns	
Minimum P _L pulse width; LOW	5	t _{WPLL}	120	60		ns	
	10		45	20		ns	
	15		30	15		ns	
Recovery time for MR	5	t _{RMR}	125	65		ns	
	10		70	35		ns	
	15		50	25		ns	
Recovery time for P _L	5	t _{RPL}	90	45		ns	
	10		35	15		ns	
	15		25	10		ns	
Maximum clock pulse frequency	5	f _{max}	2,5	5		MHz	
	10		7	14		MHz	
	15		9	18		MHz	

4-bit up/down decade counter

HEF40192B
MSI

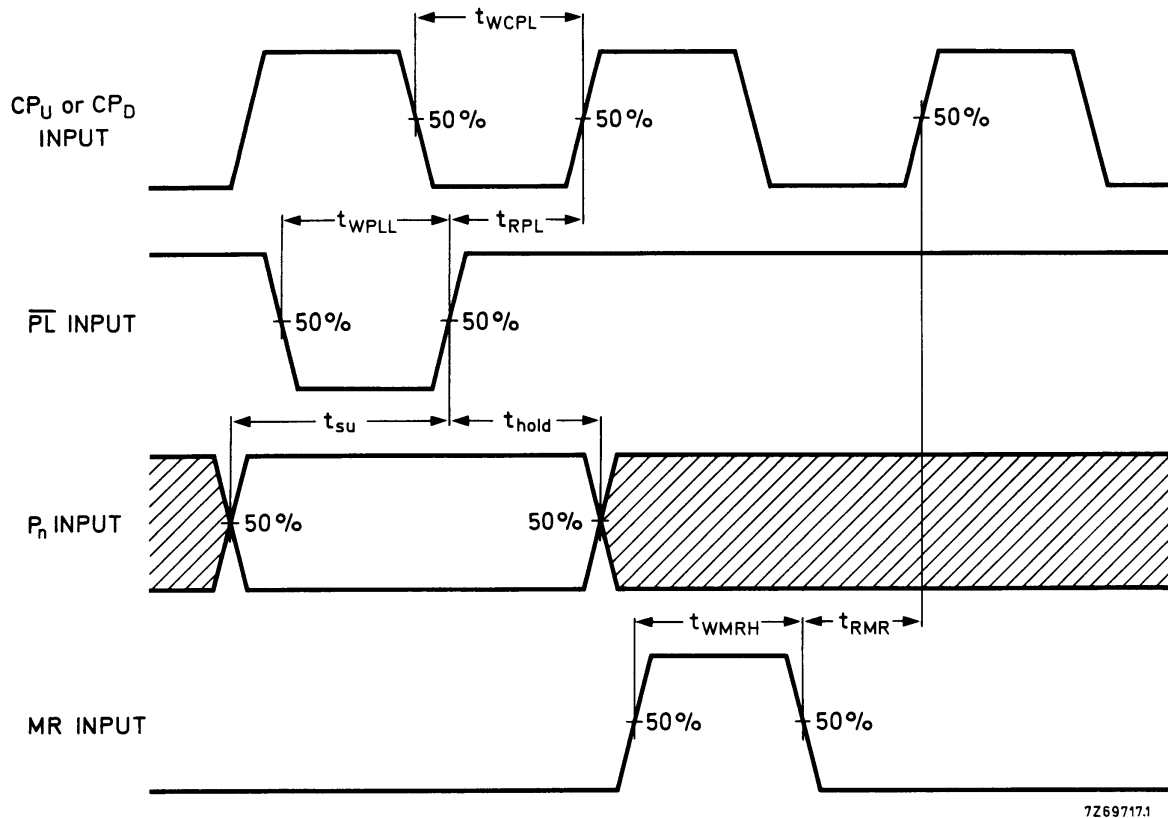

7269717.1

Fig.6 Waveforms showing recovery times for $\overline{P_L}$ and MR, minimum pulse widths for CP_U, CP_D, $\overline{P_L}$ and MR, and set-up and hold times for P to $\overline{P_L}$. Set-up times and hold times are shown as positive values but may be specified as negative values.

4-bit up/down decade counter

HEF40192B
MSI

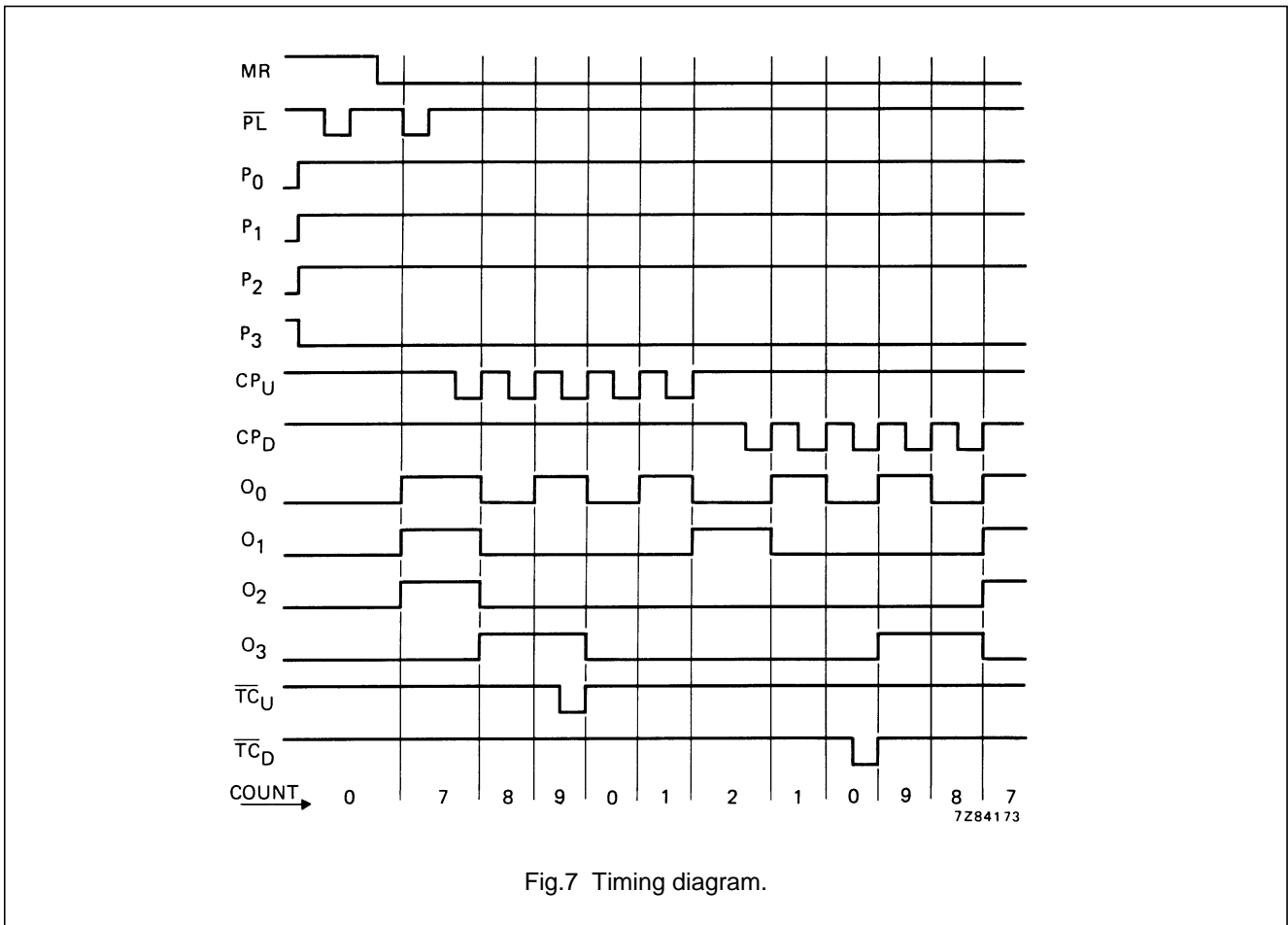

Fig.7 Timing diagram.

APPLICATION INFORMATION

Some examples of applications for the HEF40192B are:

- Up/down difference counting
- Multistage ripple counting
- Multistage synchronous counting.

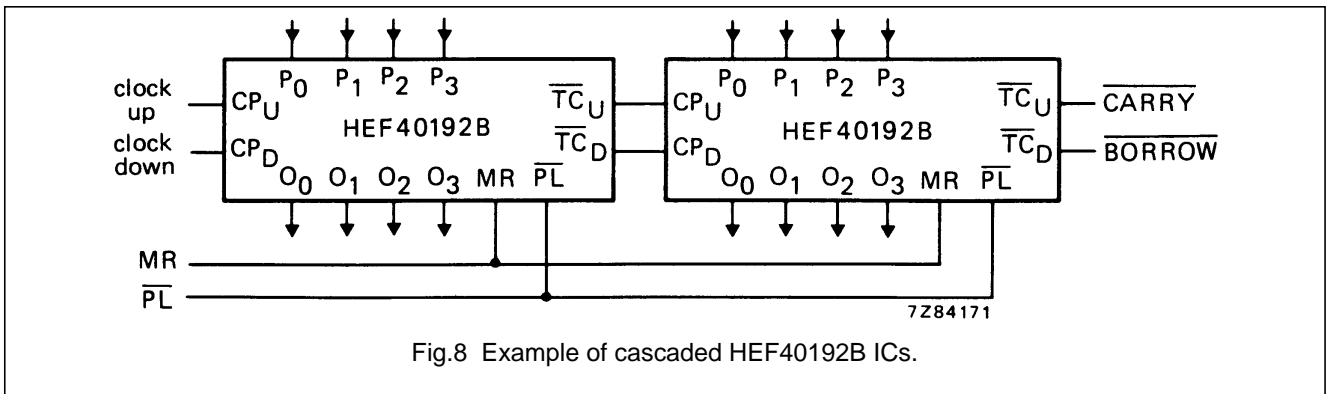

Fig.8 Example of cascaded HEF40192B ICs.