

# DATA SHEET

For a complete data sheet, please also download:

- The IC04 LOCMOS HE4000B Logic Family Specifications HEF, HEC
- The IC04 LOCMOS HE4000B Logic Package Outlines/Information HEF, HEC

## **HEF4031B**

## **MSI**

## **64-stage static shift register**

Product specification  
File under Integrated Circuits, IC04

January 1995

# 64-stage static shift register

# HEF4031B MSI

### DESCRIPTION

The HEF4031B is an edge-triggered 64-stage static shift register with two serial data inputs ( $D_A$ ,  $D_B$ ), a data select input  $\bar{A}/B$ , a clock input (CP), a buffered clock output (CO), and buffered outputs from the 64th bit position ( $O_{63}$ ,  $\bar{O}_{63}$ ). The output  $O_{63}$  is capable of driving one TTL load.

Data from  $D_A$  or  $D_B$ , as determined by the state of  $\bar{A}/B$ , is shifted into the first shift register position and all the data in

the register is shifted one position to the right on the LOW to HIGH transition of CP.  $D_A$  is selected by a LOW, and  $D_B$  by a HIGH on  $\bar{A}/B$ . Registers can be cascaded either by connecting all CP inputs together or by driving CP of the most right-hand register with the system clock and connecting CO to CP of the preceding register. When the second technique is used in the recirculating mode, a flip-flop must be used to store  $O_{63}$  of the most right-hand register until the most left-hand register is clocked.

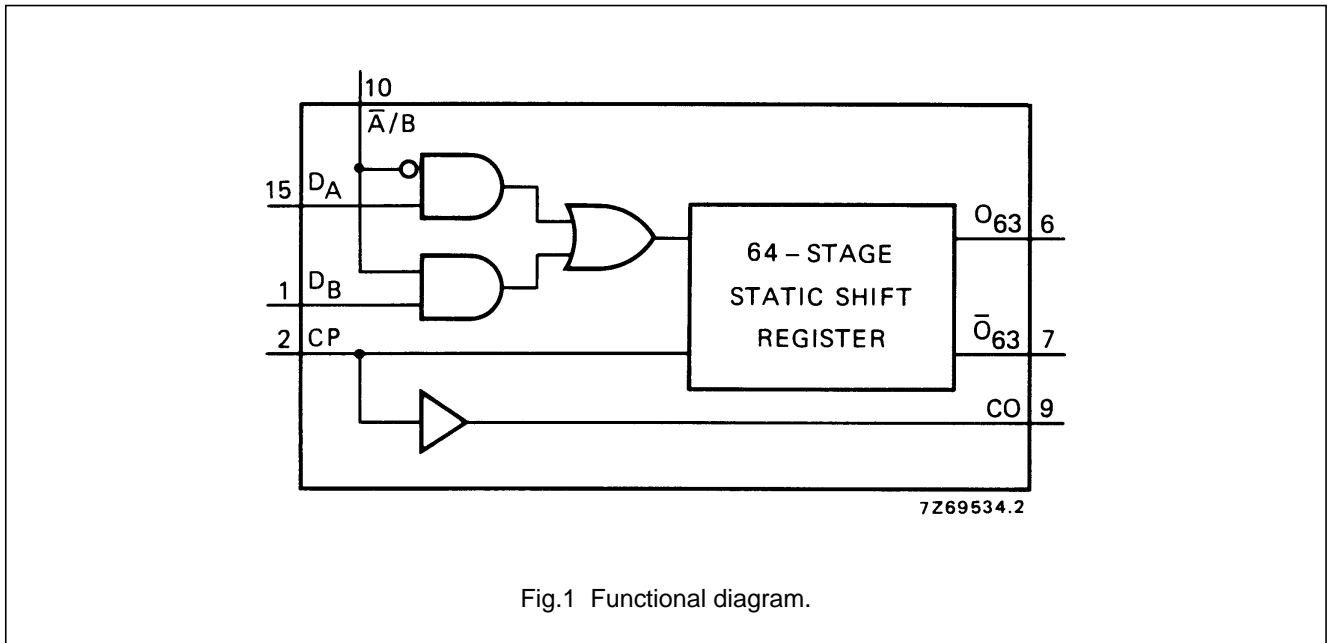

Fig.1 Functional diagram.

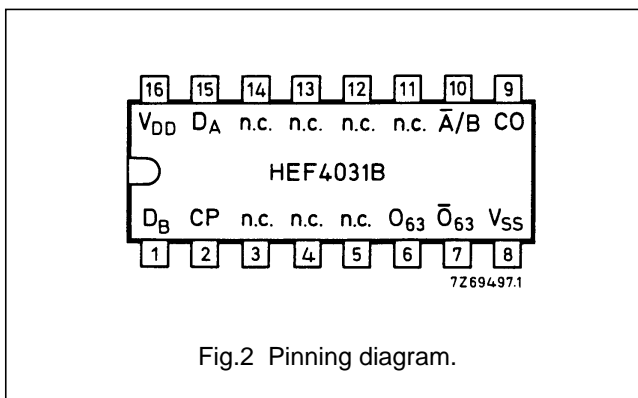

Fig.2 Pinning diagram.

### PINNING

- $D_A$ ,  $D_B$  data inputs
- $\bar{A}/B$  data select input
- CP clock input (LOW to HIGH edge-triggered)
- CO buffered clock output
- $O_{63}$  buffered output from the 64th stage
- $\bar{O}_{63}$  complementary buffered output from the 64th stage

### FAMILY DATA, $I_{DD}$ LIMITS category MSI

See Family Specifications

- HEF4031BP(N): 16-lead DIL; plastic (SOT38-1)
- HEF4031BD(F): 16-lead DIL; ceramic (cerdip) (SOT74)
- HEF4031BT(D): 16-lead SO; plastic (SOT109-1)
- ( ): Package Designator North America

64-stage static shift register

HEF4031B  
MSI

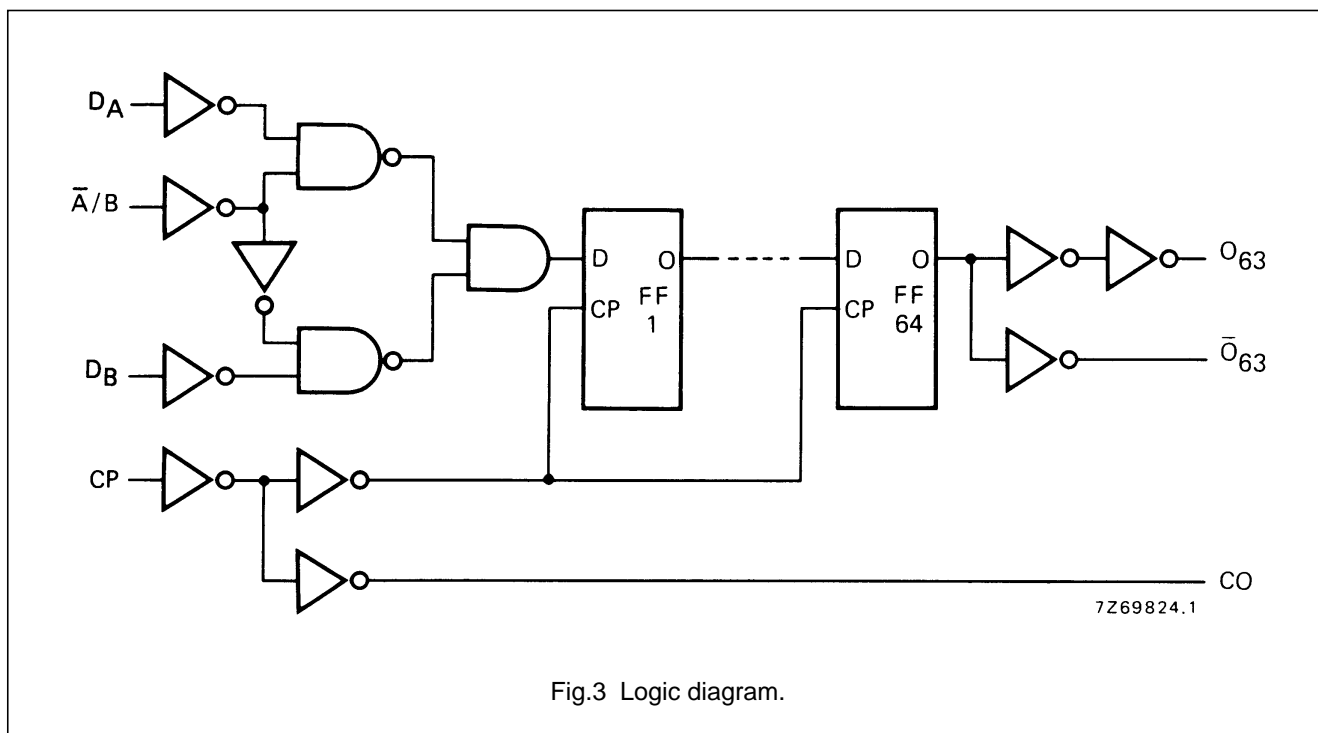

Fig.3 Logic diagram.

**DC CHARACTERISTICS**

$V_{SS} = 0\text{ V}$ ;  $V_I = V_{SS}$  or  $V_{DD}$

	$V_{DD}$ V	$V_{OH}$ V	$V_{OL}$ V	SYMBOL	$T_{amb}$ (°C)					
					-40		+ 25		+ 85	
					MIN.	MAX.	MIN.	MAX.	MIN.	MAX.
Output (source)	5	4, 6			1,0	0,85	0,65		mA	
current	10	9,5		$-I_{OH}$	3,0	2,5	2,0		mA	
HIGH; $O_{63}$	15	13,5			10,0	8,5	6,5		mA	
HIGH; $\bar{O}_{63}$	5	2,5		$-I_{OH}$	3,0	2,5	2,0		mA	
Output (sink)	4,75		0,4		2,7	2,3	1,8		mA	
current	10		0,5	$I_{OL}$	9,5	8,0	6,3		mA	
LOW; $O_{63}$	15		1,5		24,0	20,0	16,0		mA	

## 64-stage static shift register

HEF4031B  
MSI**AC CHARACTERISTICS** $V_{SS} = 0\text{ V}$ ;  $T_{amb} = 25\text{ }^{\circ}\text{C}$ ;  $C_L = 50\text{ pF}$ ; input transition times  $\leq 20\text{ ns}$ 

	$V_{DD}$ V	SYMBOL	MIN.	TYP.	MAX.	TYPICAL EXTRAPOLATION FORMULA							
Propagation delays	5	$t_{PHL}$		180	360	ns	$167\text{ ns} + (0,26\text{ ns/pF}) C_L$						
								CP $\rightarrow$ $O_{63}$					
								HIGH to LOW					
	10	$t_{PHL}$			65	130	ns	$57\text{ ns} + (0,16\text{ ns/pF}) C_L$					
									15	45	90	ns	$40\text{ ns} + (0,11\text{ ns/pF}) C_L$
									5	170	340	ns	$148\text{ ns} + (0,45\text{ ns/pF}) C_L$
	LOW to HIGH	$t_{PLH}$			65	130	ns	$56\text{ ns} + (0,19\text{ ns/pF}) C_L$					
									10	45	90	ns	$39\text{ ns} + (0,13\text{ ns/pF}) C_L$
									15	190	380	ns	$163\text{ ns} + (0,55\text{ ns/pF}) C_L$
	CP $\rightarrow$ $\overline{O}_{63}$	$t_{PHL}$			75	150	ns	$64\text{ ns} + (0,23\text{ ns/pF}) C_L$					
									10	50	100	ns	$42\text{ ns} + (0,16\text{ ns/pF}) C_L$
									15	190	380	ns	$163\text{ ns} + (0,55\text{ ns/pF}) C_L$
LOW to HIGH	$t_{PLH}$			75	150	ns	$64\text{ ns} + (0,23\text{ ns/pF}) C_L$						
								10	50	100	ns	$42\text{ ns} + (0,16\text{ ns/pF}) C_L$	
								15	70	140	ns	$43\text{ ns} + (0,55\text{ ns/pF}) C_L$	
CP $\rightarrow$ CO	$t_{PHL}$			35	70	ns	$24\text{ ns} + (0,23\text{ ns/pF}) C_L$						
								10	25	50	ns	$17\text{ ns} + (0,16\text{ ns/pF}) C_L$	
								15	55	110	ns	$28\text{ ns} + (0,55\text{ ns/pF}) C_L$	
LOW to HIGH	$t_{PLH}$			30	60	ns	$19\text{ ns} + (0,23\text{ ns/pF}) C_L$						
								10	25	50	ns	$17\text{ ns} + (0,16\text{ ns/pF}) C_L$	
								15	25	50	ns	$17\text{ ns} + (0,16\text{ ns/pF}) C_L$	
Output transition times; $O_{63}$	5	$t_{THL}$		25	50	ns	$5\text{ ns} + (0,40\text{ ns/pF}) C_L$						
								10	12	24	ns	$3\text{ ns} + (0,18\text{ ns/pF}) C_L$	
								15	8	16	ns	$2\text{ ns} + (0,13\text{ ns/pF}) C_L$	
	LOW to HIGH	$t_{TLH}$			40	80	ns	$8\text{ ns} + (0,65\text{ ns/pF}) C_L$					
									10	20	40	ns	$5\text{ ns} + (0,30\text{ ns/pF}) C_L$
									15	13	26	ns	$3\text{ ns} + (0,20\text{ ns/pF}) C_L$
Output transition times; $\overline{O}_{63}$ , CO	5	$t_{THL}$		60	120	ns	$10\text{ ns} + (1,0\text{ ns/pF}) C_L$						
								10	30	60	ns	$9\text{ ns} + (0,42\text{ ns/pF}) C_L$	
								15	20	40	ns	$6\text{ ns} + (0,28\text{ ns/pF}) C_L$	
	LOW to HIGH	$t_{TLH}$			60	120	ns	$10\text{ ns} + (1,0\text{ ns/pF}) C_L$					
									10	30	60	ns	$9\text{ ns} + (0,42\text{ ns/pF}) C_L$
									15	20	40	ns	$6\text{ ns} + (0,28\text{ ns/pF}) C_L$

64-stage static shift register

HEF4031B  
MSI

**AC CHARACTERISTICS**

V<sub>SS</sub> = 0 V; T<sub>amb</sub> = 25 °C; C<sub>L</sub> = 50 pF; input transition times ≤ 20 ns

	V <sub>DD</sub> V	SYMBOL	MIN.	TYP.	MAX.	TYPICAL EXTRAPOLATION FORMULA	
Set-up times D <sub>A</sub> , D <sub>B</sub> → CP	5	t <sub>su</sub>	25	0	ns	see also waveforms Fig.4	
	10		25	-5	ns		
	15		10	-10	ns		
	A̅/B → CP	5	t <sub>su</sub>	30	10		ns
		10		15	0		ns
		15		10	-5		ns
Hold times D <sub>A</sub> , D <sub>B</sub> → CP	5	t <sub>hold</sub>	40	10	ns		
	10		40	10	ns		
	15		40	10	ns		
	A̅/B → CP	5	t <sub>hold</sub>	40	10		ns
		10		40	10		ns
		15		40	10		ns
Minimum clock pulse width; LOW	5	t <sub>WCPL</sub>	180	90	ns		
	10		70	35	ns		
	15		50	25	ns		
Maximum clock pulse frequency	5	f <sub>max</sub>	2,5	5	MHz		
	10		7	14	MHz		
	15		10	20	MHz		

**AC CHARACTERISTICS**

V<sub>SS</sub> = 0 V; T<sub>amb</sub> = 25 °C; input transition times ≤ 20 ns

	V <sub>DD</sub> V	TYPICAL FORMULA FOR P (μW)	
Dynamic power dissipation per package (P)	5	4000 f <sub>i</sub> + ∑ (f <sub>o</sub> C <sub>L</sub> ) × V <sub>DD</sub> <sup>2</sup>	where f <sub>i</sub> = input freq. (MHz) f <sub>o</sub> = output freq. (MHz) C <sub>L</sub> = load capacitance (pF) ∑ (f <sub>o</sub> C <sub>L</sub> ) = sum of outputs V <sub>DD</sub> = supply voltage (V)
	10	19 000 f <sub>i</sub> + ∑ (f <sub>o</sub> C <sub>L</sub> ) × V <sub>DD</sub> <sup>2</sup>	
	15	54 000 f <sub>i</sub> + ∑ (f <sub>o</sub> C <sub>L</sub> ) × V <sub>DD</sub> <sup>2</sup>	

64-stage static shift register

HEF4031B  
MSI

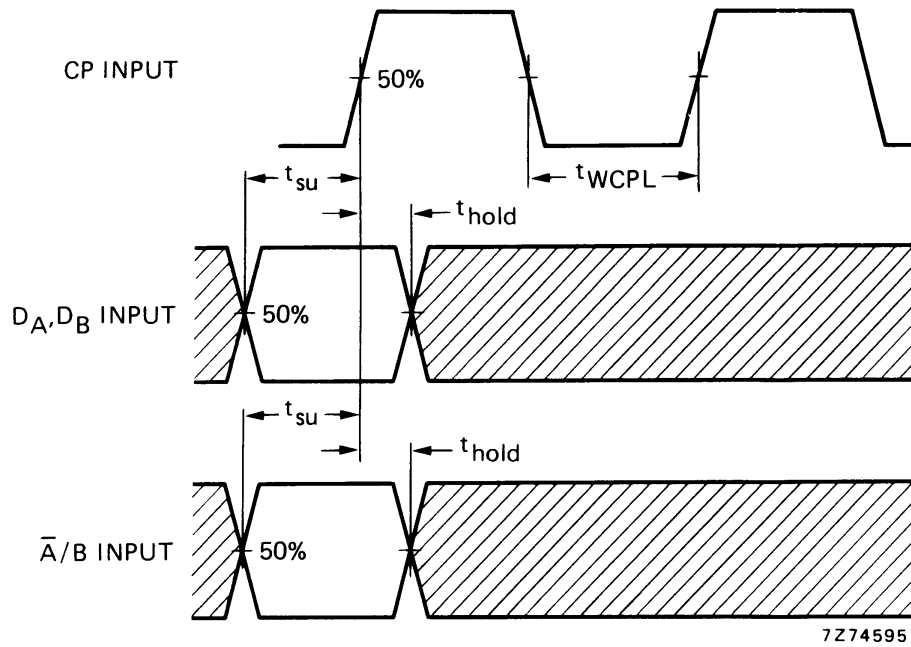

Fig.4 Waveforms showing minimum clock pulse width, set-up and hold times for  $D_A, D_B$  to CP and  $\bar{A}/B$  to CP. Set-up and hold times are shown as positive values but may be specified as negative values.

**APPLICATION INFORMATION**

An example of an application for the HEF4031B is:

- Serial shift register.

64-stage static shift register

HEF4031B  
MSI

APPLICATION INFORMATION

