

International IR Rectifier

HFA04SD60S

Ultrafast, Soft Recovery Diode

Features

- Ultrafast Recovery Time
- Ultrasoft Recovery
- Very Low I_{RRM}
- Very Low Q_{rr}
- Guaranteed Avalanche
- Specified at Operating Temperature

$t_{rr} = 38ns$
$I_{F(AV)} = 4Amp$
$V_R = 600V$

Benefits

- Reduced RFI and EMI
- Reduced Power Loss in Diode and Switching Transistor
- Higher Frequency Operation
- Reduced Snubbing
- Reduced Parts Count

Description/ Applications

These diodes are optimized to reduce losses and EMI/RFI in high frequency power conditioning systems. The softness of the recovery eliminates the need for a snubber in most applications. These devices are ideally suited for freewheeling, flyback, power converters, motor drives, and other applications where high speed and reduced switching losses are design requirements.

Package Outline

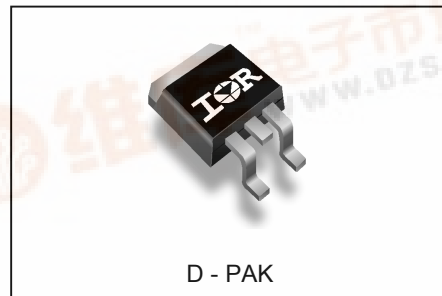

Absolute Maximum Ratings

Parameters	Max	Units
V_{RRM} Cathode-to-Anode Voltage	600	V
$I_{F(AV)}$ Continuous Forward Current $T_C = 100^\circ C$	4	A
I_{FSM} Single Pulse Forward Current	25	
I_{FRM} Peak Repetitive Forward Current $T_C = 116^\circ C$	16	
P_D Maximum Power Dissipation $T_C = 100^\circ C$	10	W
T_J, T_{STG} Operating Junction and Storage Temperatures	- 55 to 150	$^\circ C$

Electrical Characteristics @ T_J = 25°C (unless otherwise specified)

Parameters	Min	Typ	Max	Units	Test Conditions
V _{BR} , V _r Breakdown Voltage, Blocking Voltage	600	-	-	V	I _R = 100μA
V _F Forward Voltage See Fig. 1	-	1.5	1.8	V	I _F = 4A
	-	1.8	2.2	V	I _F = 8A
	-	1.4	1.7	V	I _F = 4A, T _J = 125°C
I _R Max. Reverse Leakage Current	-	0.17	3.0	μA	V _R = V _R Rated
	-	44	300	μA	T _J = 125°C, V _R = 0.8 x V _R Rated
C _T Junction Capacitance	-	4	8	pF	V _R = 200V
L _S Series Inductance	-	8.0	-	nH	Measured lead to lead 5mm from package body

Dynamic Recovery Characteristics @ T_J = 25°C (unless otherwise specified)

Parameters	Min	Typ	Max	Units	Test Conditions
t _{rr} Reverse Recovery Time	-	17	-	ns	I _F = 1.0A, di _F /dt = 200A/μA, V _R = 30V
	-	28	42		T _J = 25°C
	-	38	57		T _J = 125°C
I _{RRM} Peak Recovery Current	-	2.9	5.2	A	T _J = 25°C
	-	3.7	6.7		T _J = 125°C
Q _{rr} Reverse Recovery Charge	-	40	60	nC	T _J = 25°C
	-	70	105		T _J = 125°C
di _(rec) /dt Rate of Fall of recovery Current	-	280	-	A/μs	T _J = 25°C
	-	235	-		T _J = 125°C

Thermal - Mechanical Characteristics

Parameters	Min	Typ	Max	Units
T _J Max. Junction Temperature Range	-	-	-55 to 150	°C
T _{Stg} Max. Storage Temperature Range	-	-	-55 to 150	
T _S Soldering Temperature, 10 sec	-	-	240	
R _{thJC} Thermal Resistance, Junction to Case	-	-	5.0	°C/ W
R _{thJA} ^① Thermal Resistance, Junction to Ambient	-	-	80	
Wt Weight	-	2.0	-	g
	-	0.07	-	(oz)
T Mounting Torque	6.0	-	12	Kg*cm
	5.0	-	10	lbf*in

① Typical Socket Mount

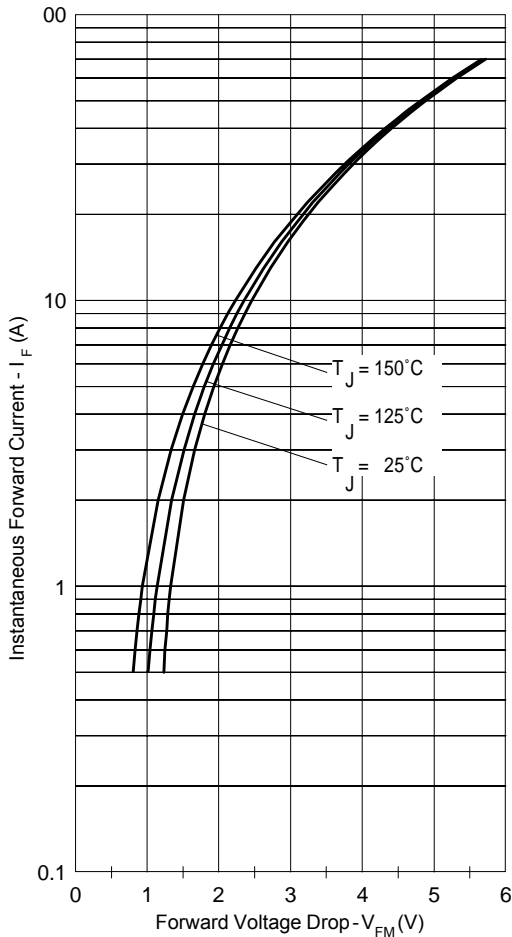

Fig. 1 - Typical Forward Voltage Drop Characteristics

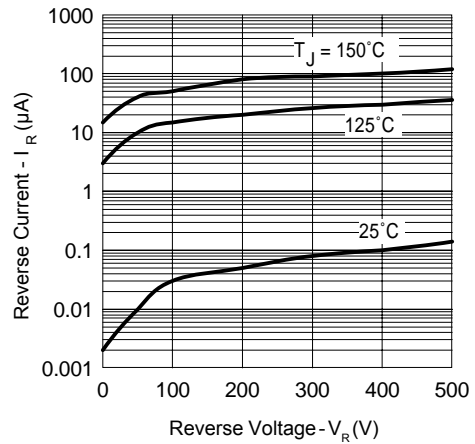

Fig. 2 - Typical Values Of Reverse Current Vs. Reverse Voltage

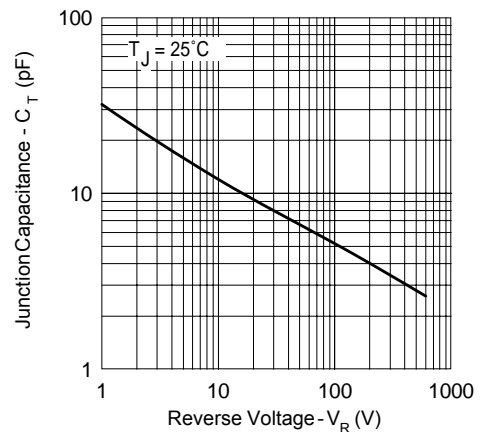

Fig. 3 - Typical Junction Capacitance Vs. Reverse Voltage

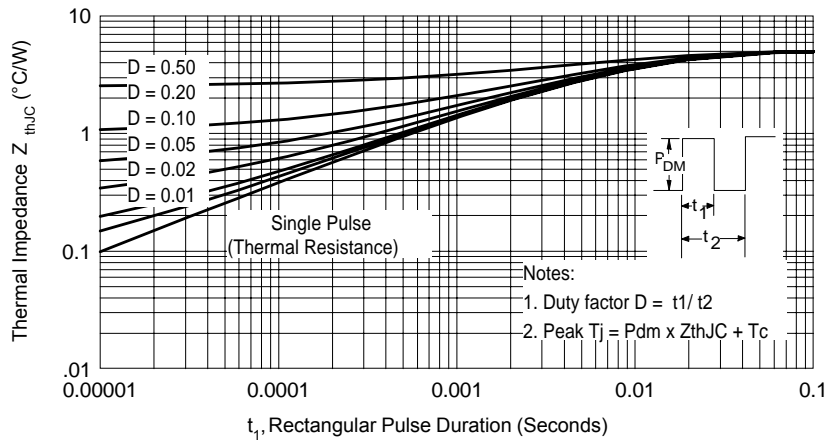

Fig. 4 - Max. Thermal Impedance Z_{thJC} Characteristics

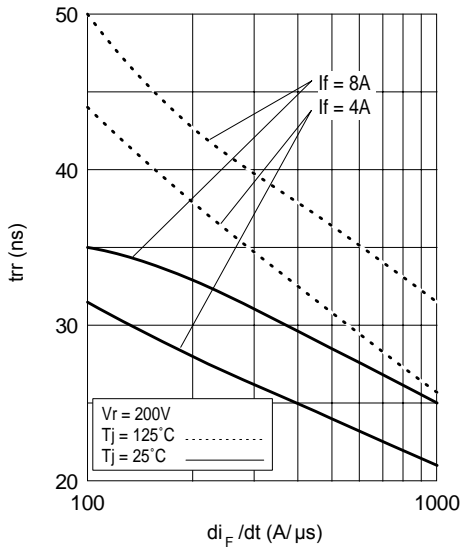

Fig. 5 - Typical Reverse Recovery vs. di_F/dt

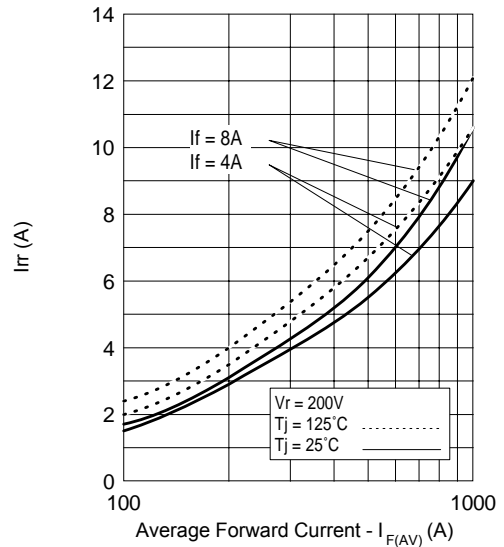

Fig. 6 - Typical Recovery Current vs. di_F/dt

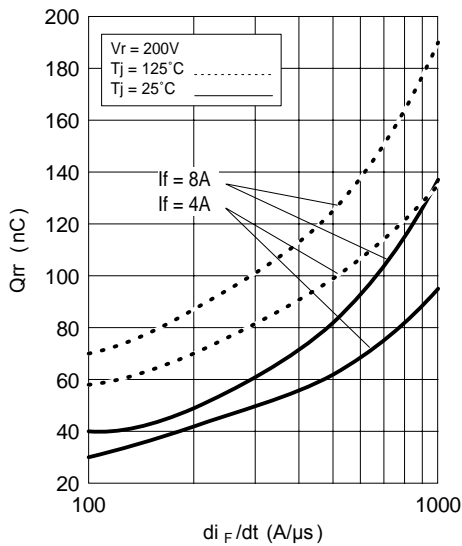

Fig. 7 - Typical Stored Charge vs. di_F/dt

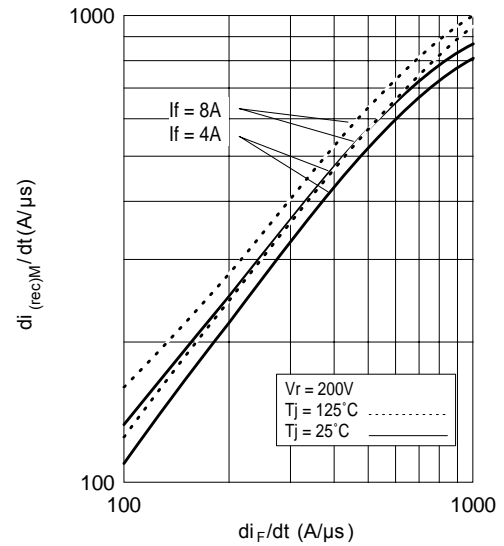

Fig. 8 - Typical $di_{(rec)M}/dt$ vs. di_F/dt

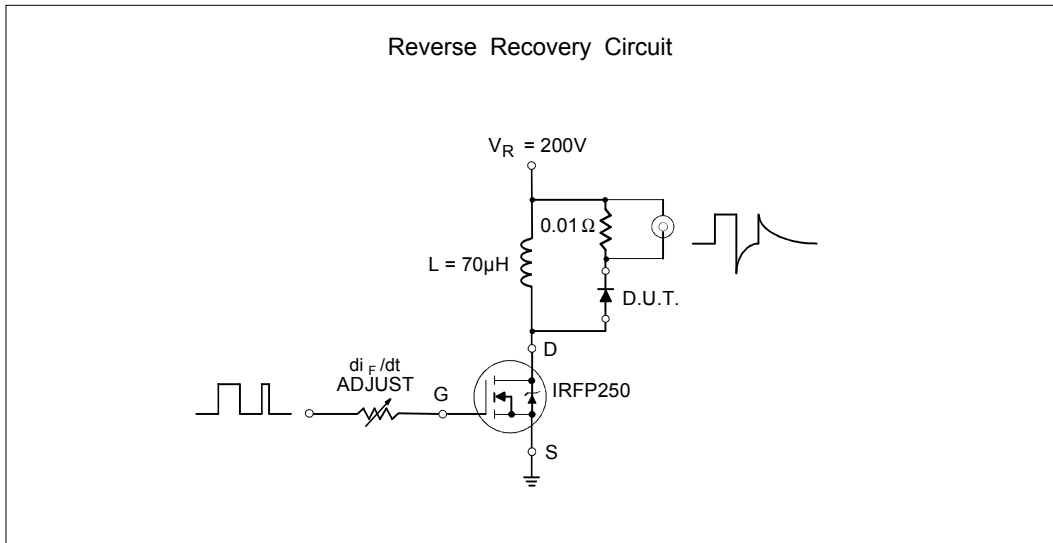

Fig. 9- Reverse Recovery Parameter Test Circuit

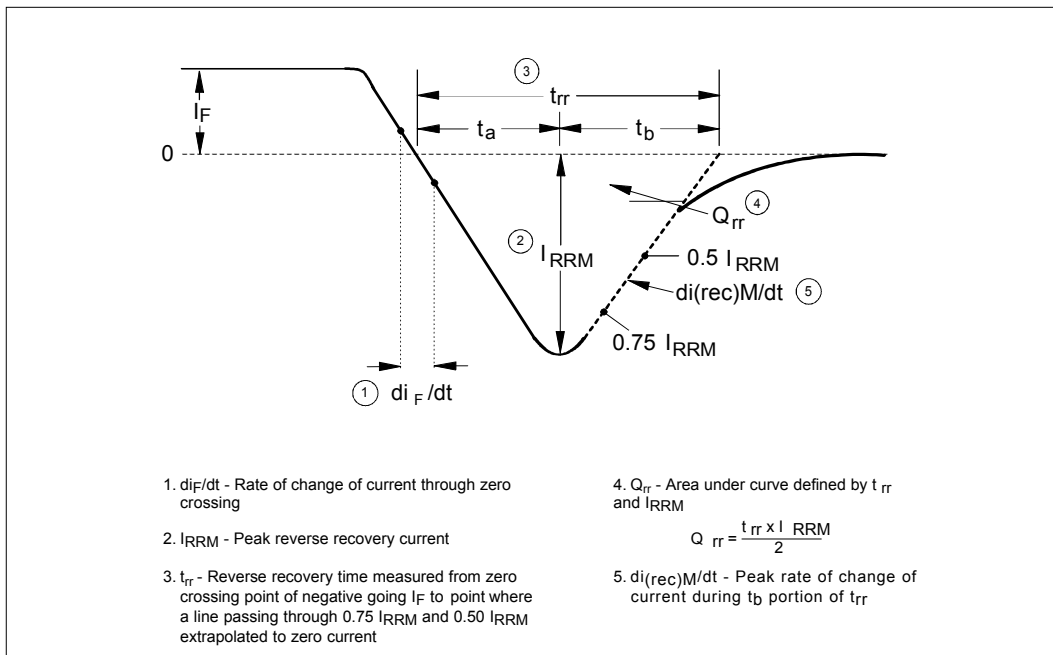
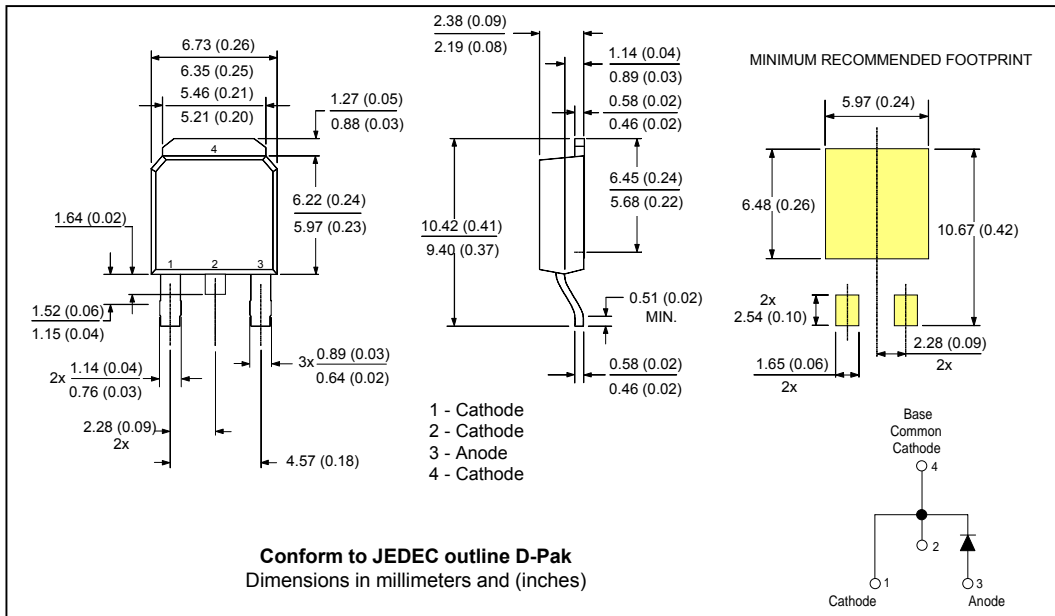
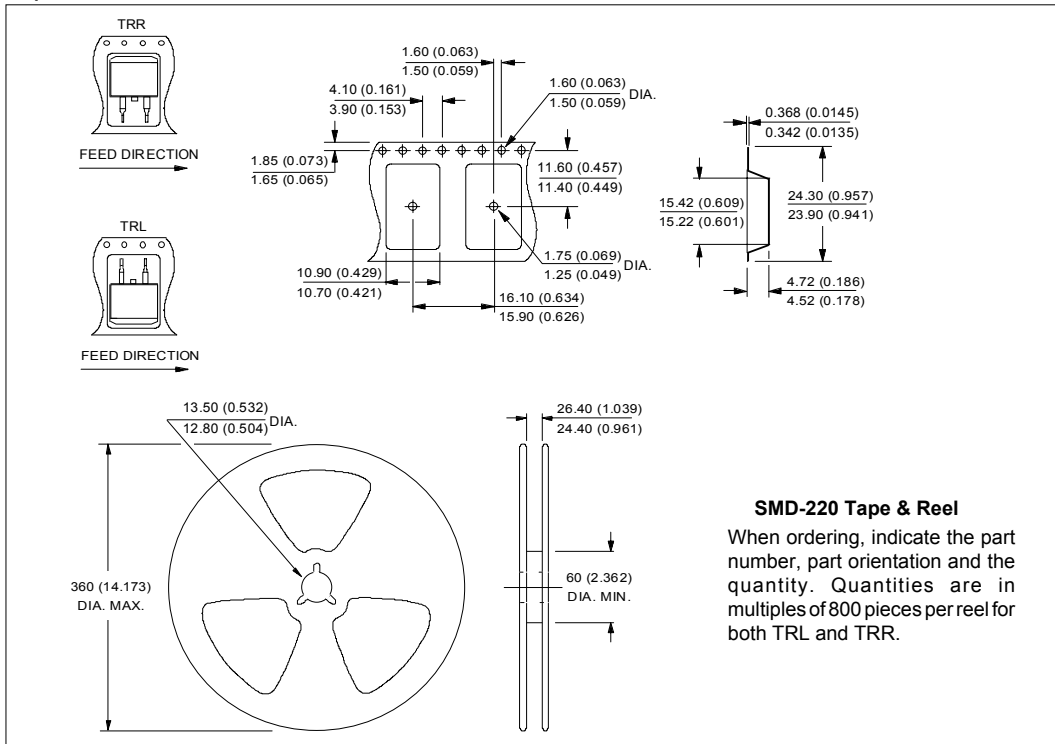

Fig. 10 - Reverse Recovery Waveform and Definitions

Outline Table



Tape & Reel Information



Marking Information

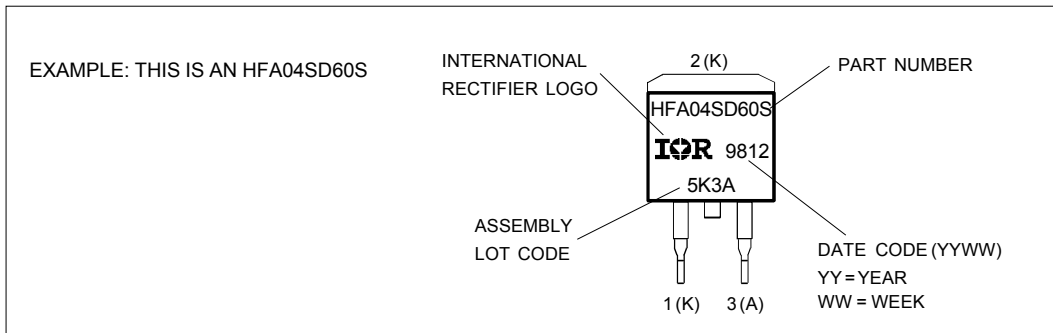

Ordering Information Table

Device Code

HF	A	04	SD	60	S
1	2	3	4	5	6

- 1** - Hexfred Family
- 2** - Electron Irradiated
- 3** - Current Rating (04 = 4A)
- 4** - D-PAK
- 5** - Voltage Rating (60 = 600V)
- 6** - Suffix

S	= D ² PAK/ Dpak
TR	= Tape & Reel
TRL	= Tape & Reel Left
TRR	= Tape & Reel Right

Data and specifications subject to change without notice.
 This product has been designed and qualified for Industrial Level.
 Qualification Standards can be found on IR's Web site.