



2.0GHz to 2.7GHz DownConverter



The HFA3661 is a monolithic bipolar device for down conversion applications in the 2.0GHz to 2.7GHz range. Manufactured in the Intersil UHF1X process, the device consists of a low

noise amplifier and down conversion mixer. An energy saving power enable control feature assures isolation between transmit and receive channels for TDMA and/or half duplex systems. The device is designed for a high Output IP3, while maintaining low current and 5.5V to 2.7V supply operation. It requires low drive levels from the local oscillator and is housed in a small outline 20 lead SSOP package ideally suited for PCMCIA card applications.

Ordering Information

PART NUMBER	TEMP. RANGE (°C)	PACKAGE	PKG. NO.
HFA3661IA	-40 to 85	20 Ld SSOP	M20.15
HFA3661IA96	-40 to 85	Tape and Reel	

Pinout

HFA3661 (SSOP) TOP VIEW

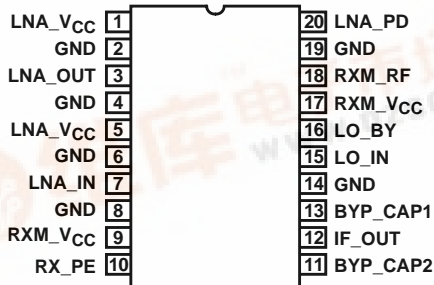

Features

- RF Frequency Range 2.0GHz to 2.7GHz
- IF Operation 10MHz to 250MHz
- High Conversion Gain 2.0GHz 40dB
2.7GHz 36dB
- High Output IP3 11dBm
- Single Supply Battery Operation 2.7V to 5.5V
- Power Enable Control
- LNA Bypass Control

Applications

- Wireless Local Loop Systems
- PCMCIA Wireless Transceiver
- Wireless Local Area Network Modems
- CDMA/TDMA Packet Protocol Radios
- Full Duplex Transceivers
- Portable Battery Powered Equipment

Block Diagram

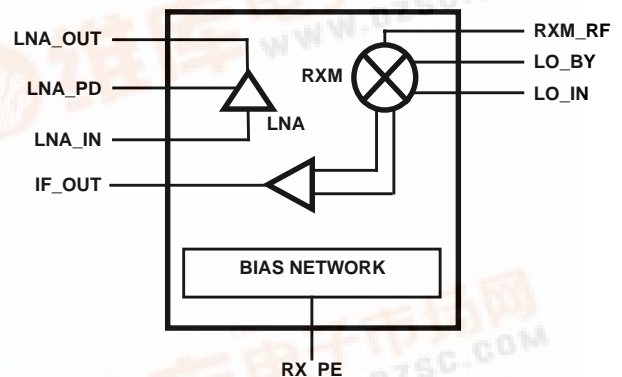

POWER CONTROL TRUTH TABLE

STATE	LNA_PD	RCV_PE
Power Down Mode (LNA, Mixer, and IF Buffer are Power Down)	High or Low	Low
Receive Mode (Mixer Active, LNA Active)	Low	High
Attenuated Receive Mode (LNA Power Down used for RF Signal Attenuation)	High	High

NOTE: LNA_PD and RCV_PE are floating pins.



HFA3661

Typical Application Diagram

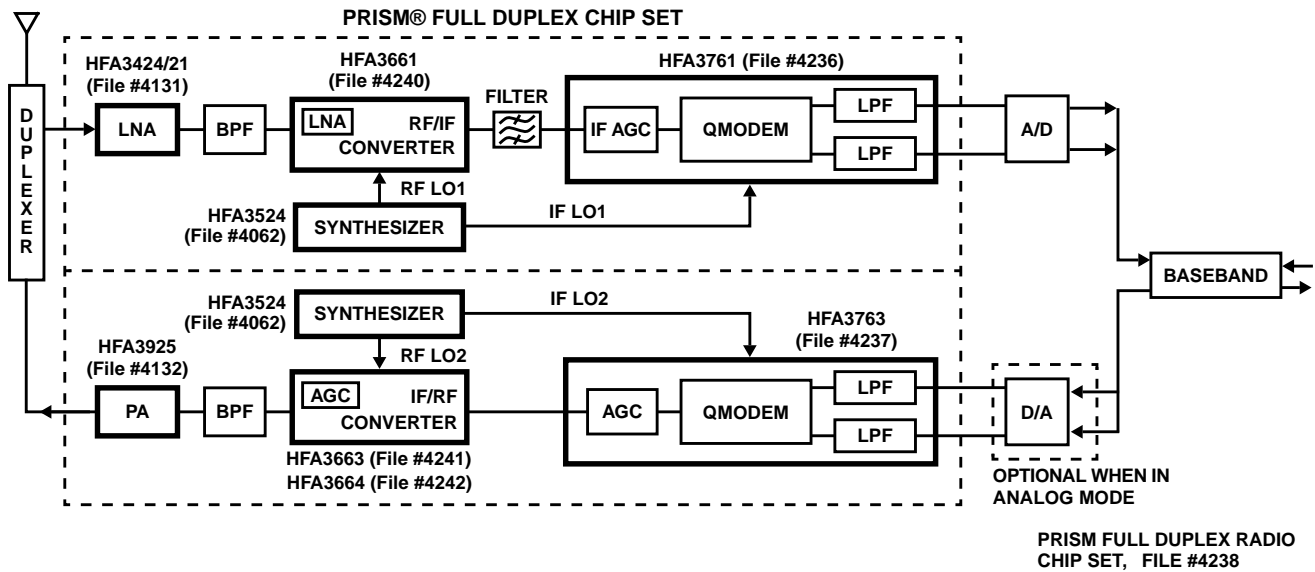

Pin Descriptions

PIN NO.	NAME	DESCRIPTION
1	LNA_VCC	Low Noise Amplifier Positive Power Supply (1 of 2)
2	GND	Low Noise Amplifier Ground
3	LNA_OUT	Low Noise Amplifier RF Output
4	GND	Low Noise Amplifier Ground
5	LNA_VCC	Low Noise Amplifier Positive Power Supply (2 of 2)
6	GND	Low Noise Amplifier Ground
7	LNA_IN	Low Noise Amplifier RF Input
8	GND	Low Noise Amplifier Ground
9	RXM_VCC	Receive Mixer Positive Power Supply
10	RX_PE	Receive Channel Power Enable (LNA, Mixer, and IF Buffer)
11	BYP_CAP2	Bypass Capacitor
12	IF_OUT	Receive Mixer Buffered IF Output
13	BYP_CAP1	Bypass Capacitor
14	GND	IF Buffer Ground
15	LO_IN	Receive Mixer Local Oscillator Input
16	LO_BY	Receive Mixer Local Oscillator Bypass
17	RXM_VCC	Receive Mixer Positive Power Supply
18	RXM_RF	Receive Mixer RF Input
19	GND	Receive Mixer Ground
20	LNA_PD	Low Noise Amplifier Power Down (Bypass mode used for RF Signal Attenuation)

HFA3661

Absolute Maximum Ratings

Supply Voltage -0.3 to 6.0V
 Voltage on Any Other Pin -0.3 to V_{CC} 0.3V

Operating Conditions

Supply Voltage Range 2.7V to 5.5V

Thermal Information

Thermal Resistance (Typical, Note 1) θ_{JA} (°C/W)
 20 Lead Plastic SSOP 110
 Package Power Dissipation at 70°C
 20 Lead Plastic SSOP 0.7W
 Maximum Junction Temperature (Plastic Package) 150°C
 Maximum Temperature Range $-40^{\circ}\text{C} \leq T_A \leq 85^{\circ}\text{C}$
 Maximum Storage Temperature Range $-65^{\circ}\text{C} \leq T_A \leq 150^{\circ}\text{C}$
 Maximum Lead Temperature (Soldering 10s) 300°C
 (At Lead Tips Only)

CAUTION: Stresses above those listed in "Absolute Maximum Ratings" may cause permanent damage to the device. This is a stress only rating and operation of the device at these or any other conditions above those indicated in the operational sections of this specification is not implied.

NOTE:

- θ_{JA} is measured with the component mounted on an evaluation PC board in free air.

Electrical Specifications $V_{CC} = 5.5\text{V}$, $Z_0 = 50\Omega$, Unless Otherwise Specified

PARAMETER		SYMBOL	(NOTE 2) TEST LEVEL	TEMP (°C)	MIN	TYP	MAX	UNITS
CASCADED CHARACTERISTICS (External Reactive Match on IF_OUT to 50Ω, -3dB Loss RF Image Filter, LO_IN = 2080MHz/-3dBm, RF = 2150MHz/-30dBm, Receive Mode)								
Cascaded Power Gain	2.0GHz	CRX_PG2.0	B	Full	-	40	-	dB
	2.7GHz	CRX_PG2.7	B	Full	-	36	-	dB
Cascaded OIP3 (RF = 2300.1MHz, 2299.9MHz/-30dBm)	2.0GHz	CRX_IP3_2.0	B	Full	-	14.9	-	dBm
	2.7GHz	CRX_IP3_2.7	B	Full	-	11.0	-	dBm
Cascaded Noise Figure at 2.4GHz		CRX_NF2.4	B	Full	-	4.4	-	dB
Cascaded Output 1dB Compression	2.0GHz	CRX_P1D2.0	B	Full	-	2.8	-	dBm
	2.7GHz	CRX_P1D2.7	B	Full	-	3.8	-	dBm
LO INPUT CHARACTERISTICS (LO_IN = 2080MHz/-3dBm, all unused inputs and outputs are terminated into 50Ω)								
LO Input Frequency Range		LO_f	B	Full	1600	-	2690	MHz
LO Input Drive Level		LO_dr	B	Full	-8	-3	+3	dBm
LO Input VSWR		LO_SWR	A	Full	-	1.5:1	2.0:1	-
LO Input Return Loss		LO_IRL	A	Full	9.5	14	-	dB
LOW NOISE AMPLIFIER (LNA) CHARACTERISTICS (LNA_IN = 2300MHz/-30dBm)								
LNA Frequency Range		LNA_f	B	Full	2.0	-	2.7	GHz
LNA Noise Figure at 2.4GHz		LNA_NF2.4	B	25	-	3.3	4.0	dB
LNA Power Gain	2.0GHz	LNA_PG2.0	A	25	19	22	-	dB
	2.7GHz	LNA_PG2.7	A	25	13	16	-	dB
LNA Reverse Isolation		LNA_ISO	B	25	-	30	-	dB
LNA OIP3 at 2300.1MHz, 2299.9MHz/-30dBm	2.0GHz	LNA_IP3_2.0	A	25	9	16	-	dBm
	2.7GHz	LNA_IP3_2.7	A	25	10.5	16	-	dBm
LNA Output 1dB Compression	2.0GHz	LNA_P1D_2.0	B	25	-	0	-	dBm
	2.7GHz	LNA_P1D_2.7	B	25	-	2	-	dBm
LNA Input VSWR	2.0GHz	LNA_ISWR_2	A	25	-	1.1:1	2.0:1	-
	2.7GHz	LNA_ISWR_7	A	25	-	1.4:1	2.0:1	-
LNA Input Return Loss	2.0GHz	LNA_IRL_2.0	A	25	9.5	15.6	-	dB
	2.7GHz	LNA_IRL_2.7	A	25	9.5	26.4	-	dB

HFA3661

Electrical Specifications $V_{CC} = 5.5V$, $Z_0 = 50\Omega$, Unless Otherwise Specified (Continued)

PARAMETER		SYMBOL	(NOTE 2) TEST LEVEL	TEMP (°C)	MIN	TYP	MAX	UNITS
LNA Output VSWR	2.0GHz	LNA_OSWR_2	A	25	-	1.4:1	2.0:1	-
	2.7GHz	LNA_OSWR_7	A	25	-	1.6:1	2.0:1	-
LNA Output Return Loss	2.0GHz	LNA_ORL_2.0	A	25	9.5	15.6	-	dB
	2.7GHz	LNA_ORL_2.7	A	25	9.5	12.7	-	dB
LNA Max Power In (Functional)		LNA_MP	B	25	-4	-	-	dBm
LNA Power Down Attenuation		LNA_PD	B	25	-	36	-	dB
RECEIVE MIXER CHARACTERISTICS (LO_IN = 2230MHz/-3dBm, RXM_RF = 2300MHz/-30dBm, IF_OUT load = 50Ω with external matching network at 70MHz)								
Rx Mixer RF Frequency Range		RXM_RFf	B	Full	2.0	-	2.7	GHz
Rx Mixer IF Frequency Range		RXM_IFf	B	Full	10	-	250	MHz
Rx Mixer SSB Noise Figure at 2.4GHz		RXM_NF	B	25	-	13	15.5	dB
Rx Mixer Power Conversion Gain	2.0GHz	RXM_PG_2.0	A	25	20	22	-	dB
	2.7GHz	RXM_PG_2.7	A	25	19	23	-	dB
MixerOIP3 at 2300.1MHz, 2299.9MHz/-30dBm	2.0GHz	RXM_IP3_2.0	A	25	11	15	-	dBm
	2.7GHz	RXM_IP3_2.7	A	25	8	11	-	dBm
Rx Mixer IF Output 1dB Compression	2.0GHz	RXM_P1D2.0	B	25	-	4	-	dBm
	2.7GHz	RXM_P1D2.7	B	25	-	3	-	dBm
Rx Mixer IF_OUT Resistance (IF = 70MHz)		RXM_ROUT	B	25	-	67	-	Ω
Rx Mixer IF_OUT Capacitance (IF = 70MHz)		RXM_COUT	B	25	-	1.1	-	pF
Rx Mixer LO to RF Isolation		RXM_LOR	B	25	-	22	-	dB
Rx Amplifier Max Power Input (Functional)		RXM_MP	B	25	12	-	-	dBm
POWER SUPPLY AND LOGIC CHARACTERISTICS								
Voltage Supply Range		V_{CC}	B	Full	2.7	-	5.5	V
Receive Mode Supply Current	RCV_I _{CC}		A	25	-	48	65	mA
	RCV_I _{CC}		B	Full	-	58	75	mA
Attenuated Receive Mode Supply Current PE = V_{CC} , LNA_PD = V_{CC}	ATTN_I _{CC}		B	25	-	19	23	mA
	ATTN_I _{CC}		B	Full	-	19	25	mA
Power Down Mode Supply Current LNA_PD = GND	PD_I _{CC}		A	25	-	1	100	μA
	PD_I _{CC}		B	Full	-	1	100	μA
Logic Input Low Level		V_{IL}	A	Full	-0.2	-	0.8	V
Logic Input High Level		V_{IH}	A	Full	2.4	-	V_{CC}	V
Logic Low Input Bias Current (0V)		I_{B_LO}	B	25	-	-	5	μA
Logic High Input Bias Current (5.5V)		I_{B_HI}	B	25	-	-	50	μA
LNA_PD Power Enable Time		LNA_Et	B	Full	-	-	10	μs
LNA_PD Power Disable Time		LNA_Dt	B	Full	-	-	10	μs
RX_PE Power Enable Time		PEt	B	Full	-	-	10	μs
RX_PE Power Disable Time		PDt	B	Full	-	-	10	μs

NOTE:

- Test Level A = 100% production tested, B = Typical or Limit based on characterization data, C = Design information, goal or condition.

HFA3661

Typical Application Circuit

