

2.3GHz UpConverter with Gain Control



The HFA3663 UpConverter with Gain Control is a monolithic bipolar device for up conversion applications in the 2.0GHz to 2.3GHz range.

Manufactured in the Intersil UHF1X process, the device consists of a double balanced mixer followed by a variable gain power preamp. An energy saving, TTL Compatible, power enable input provides on/off bias current control to the mixer and amplifier. The device requires low drive levels from the local oscillator and is housed in a small outline 20 lead SSOP package ideally suited for PCMCIA card applications.

Ordering Information

PART NUMBER	TEMP. RANGE (°C)	PACKAGE	PKG. NO.
HFA3663IA	-40 to 85	20 Ld SSOP	M20.15
HFA3663IA96	-40 to 85	Tape and Reel	

Features

- RF Frequency Range 2.0GHz to 2.3GHz
- IF Operation 10MHz to 400MHz
- Gain Control Range20dB
- Single Supply Operation. 2.7V to 5.5V
- High Output 1dB Compression. 6dBm
- High Power Gain18dB
- Power Enable/Disable Control

Applications

- Wireless Local Loop Systems
- PCMCIA Wireless Transceiver
- Wireless Local Area Network Modems
- CDMA/TDMA Packet Protocol Radios
- Full Duplex Transceivers
- Portable Battery Powered Equipment

Pinout

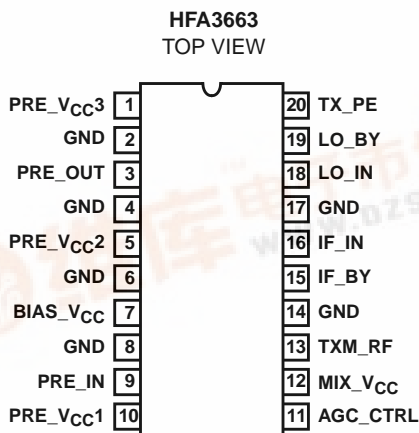

Block Diagram

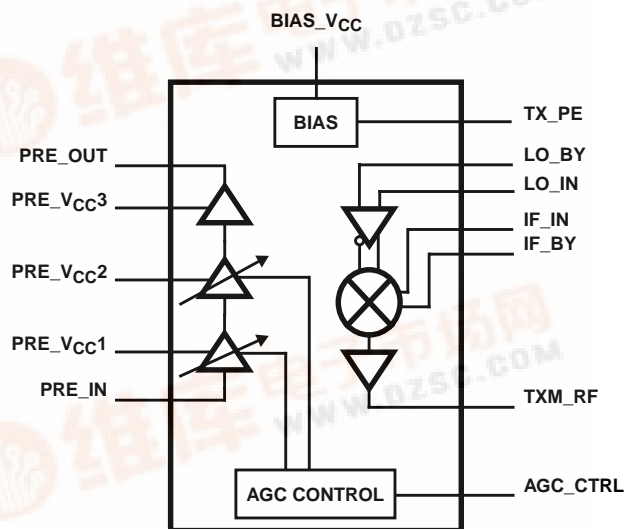

POWER CONTROL TRUTH TABLE

STATE	TX_PE
Power Down - Energy Saving Mode	Low
Transmit Mode	High



HFA3663

Typical Application Diagram

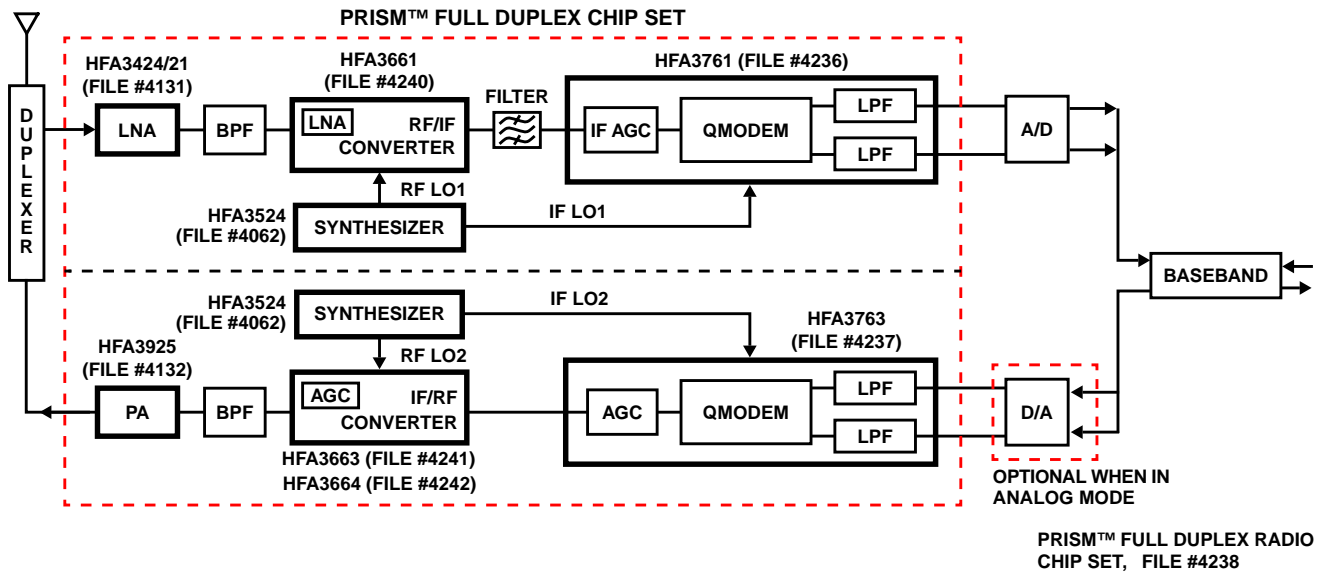

Pin Description

NAME	DESCRIPTION
LO_IN	Local Oscillator Input.
LO_BY	Local Oscillator Input Bypass (AC coupled to GND).
PRE_IN	Power Pre-Amplifier Input.
PRE_OUT	Power Pre-Amplifier Output.
PRE_VCC1	Power Pre-Amplifier 1st Stage Positive Power Supply. Use high quality RF decoupling capacitors.
PRE_VCC2	Power Pre-Amplifier 2nd Stage Positive Power Supply. Use high quality RF decoupling capacitors.
PRE_VCC3	Power Pre-Amplifier 3rd Stage Positive Power Supply. Use high quality RF decoupling capacitors.
BIAS_VCC	LO Buffer, Bias, Mixer and AGC Control Positive Power Supply. Requires an isolation coil to V _{CC} .
MIX_VCC	Transmit Mixer Output Stage Positive Power Supply. Use high quality RF decoupling capacitors.
RX_PE	Power Enable Control Input. Refer to the Power Control Truth Table.
TXM_RF	Transmit Mixer RF Output.
IF_IN	Transmit Mixer Positive IF Input. Requires external bias resistor to V _{CC} .
IF_BY	Transmit Mixer Negative IF Input (AC coupled to GND).
GND	Circuit Ground Pins (Qty 6). Internally connected with the exception of pin 17.

HFA3663

Absolute Maximum Ratings

Supply Voltage -0.3 to 6.0V
 Voltage on Any Other Pin -0.3 to V_{CC} 0.3V

Operating Conditions

Supply Voltage Range 2.7V to 5.5V

Thermal Information

Thermal Resistance (Typical, Note 1) θ_{JA} (°C/W)
 20 Lead SSOP 110
 Package Power Dissipation at 70°C
 20 Lead SSOP 0.7W
 Maximum Junction Temperature (Plastic Package) 150°C
 Maximum Temperature Range $-40^{\circ}\text{C} \leq T_A \leq 85^{\circ}\text{C}$
 Maximum Storage Temperature Range $-65^{\circ}\text{C} \leq T_A \leq 150^{\circ}\text{C}$
 Maximum Lead Temperature (Soldering 10s) 300°C
 (Lead Tips Only)

CAUTION: Stresses above those listed in "Absolute Maximum Ratings" may cause permanent damage to the device. This is a stress only rating and operation of the device at these or any other conditions above those indicated in the operational sections of this specification is not implied.

NOTE:

- θ_{JA} is measured with the component mounted on an evaluation PC board in free air.

Electrical Specifications

$V_{CC} = 5.5\text{V}$, LO = 2050MHz, IF = 100MHz, RF = 2150MHz, $Z_O = 50\Omega$,
 Unless Otherwise Specified

PARAMETER	SYMBOL	(NOTE 2) TEST LEVEL	TEMP (°C)	MIN	TYP	MAX	UNITS
CASCADED CHARACTERISTICS (-3dB Loss RF Image Filter with 35dB LO Suppression, LO_IN = 2050MHz/-6dBm, IF_IN = 100MHz/-30dBm, AGC_CTRL = 0.7V (Max Gain))							
Cascaded Output 1dB Compression	CTX_P1D	B	25	6	7.5	-	dBm
Cascaded Output Third Order Intercept	CTX_IP3	C	25	-	14	-	dBm
Cascaded Power Gain	CTX_PG	B	25	18	22	-	dB
Cascaded Power Gain Flatness (2.0GHz to 2.3GHz)	CTX_PGF	C	25	-2.5	0	+2.5	dB
Cascaded LO Leakage	CTX_LEAK	B	25	-	-20	-	dBm
LO INPUT CHARACTERISTICS (LO_IN = 2050MHz/-6dBm, all unused inputs and outputs are terminated into 50Ω)							
LO Input Frequency Range	LO_f	B	25	1.6	-	2.29	GHz
LO Input Drive Level	LO_dr	A	25	-	-6	-	dBm
LO Input VSWR	LO_SWR	A	25, 85	-	1.62:1	2.0:1	-
LO Input Return Loss	LO_IRL	A	25, 85	9.4	12.5	-	dB
TRANSMIT MIXER CHARACTERISTICS (LO_IN = 2050MHz/-6dBm, TXM_IF = 100MHz/-30dBm)							
IF Input Frequency Range	TXM_IFf	B	25	10	-	400	MHz
IF Input VSWR	TXM_SWR	A	25, 85	-	1.22:1	2.0:1	-
IF Input Return Loss	TXM_IRL	A	25, 85	9.4	23	-	dB
Power Conversion Gain (Note 3)	$V_{CC} = 5.5\text{V}$ TXM_PGH	A	25, 85	3.0	5.6	TBD	dB
Transmit Mixer LO Leakage	TXM_LEAK	A	25, 85	-	-20	-10	dBm
RF Output Frequency Range	TXM_RFf	B	25	2.0	-	2.3	GHz
RF Output VSWR	TXM_OSWR	A	25, 85	-	1.68:1	2.0:1	-
RF Output Return Loss	TXM_ORL	A	25, 85	9.4	17.4	-	dB
RF Output 1dB Compression (Note 3)	$V_{CC} = 5.5\text{V}$ TXM_P1DH	A	25	-7.8	-6.5	-	dBm
RF Output Third Order Intercept	TXM_IP3	C	25	-	2.7	-	dBm
Transmit Mixer Noise Figure	TXM_NF	B	25	-	18	-	dB

HFA3663

Electrical Specifications

$V_{CC} = 5.5V$, LO = 2050MHz, IF = 100MHz, RF = 2150MHz, $Z_O = 50\Omega$,
Unless Otherwise Specified **(Continued)**

PARAMETER	SYMBOL	(NOTE 2) TEST LEVEL	TEMP (°C)	MIN	TYP	MAX	UNITS
TRANSMIT POWER PREAMP CHARACTERISTICS (PRE_IN = 2150MHz/-30dBm, AGC_CTRL = 0.7V (Max Gain))							
Frequency Range	PRE_f	B	25	2.0	-	2.3	GHz
Power Gain (AGC_CTRL = 0.7V)	$V_{CC} = 5.5V$ PRE_PGH	A	25, 85	18	24	-	dB
Pre-Amp Noise Figure (Max Gain)	PRE_NF	B	25	-	8	-	dB
Pre-Amp AGC Range (Max - Min Gain)	PRE_AGC	A	25	20	30	-	dB
AGC Control Voltage Range	AGC_V	A	25	0.7	-	1.7	V
AGC Control Linearity	AGC_LIN	B	25	-	5:1	-	-
AGC Settling Time (Min to Max Gain)	AGC_T1	B	25	-	8.0	-	μS
AGC Settling Time (Max to Min Gain)	AGC_T2	B	25	-	0.1	-	μS
Pre-Amp RF Output 1dB Compression	$V_{CC} = 5.5V$ PRE_P1DH	A	25	8	10	-	dBm
RF Output Third Order Intercept	PRE_IP3	C	25	-	17	-	dBm
Input VSWR	PRE_ISWR	A	25, 85	-	2.7:1	3.0:1	-
Input Return Loss	PRE_IRL	A	25, 85	6.02	9.0	-	dB
Output VSWR	PRE_OSWR	A	25, 85	1.0	1.17:1	2.0:1	-
Output Return Loss	PRE_ORL	A	25, 85	9.4	15.4	-	dB
POWER SUPPLY AND LOGIC CHARACTERISTICS							
Voltage Supply Range	V_{CC}	A	25	4.5	-	5.5	V
Supply Current ($V_{CC} = 5.5V$)	I_{CC_HI}	A	25, 85	9.0	100	110	mA
	$I_{CC_HI}^T$	C	Full	-	-	110	mA
Power Down Supply Current ($V_{CC} = 5.5V$)	I_{CC_PD}	A	25	0.004	2.8	4	mA
Logic Input Low Level	V_{IL}	A	25	-0.2	-	0.8	V
Logic Input High Level	V_{IH}	A	25	2.0	-	V_{CC}	V
Logic Low Input Bias Current ($V_{PE} = 0V$, $V_{CC} = 5.5V$)	I_{B_LO}	A	25	-	-5.0	5.0	μA
Logic High Input Bias Current ($V_{PE} = 5.5V$, $V_{CC} = 5.5V$)	I_{B_HI}	A	25	-	-5.0	5.0	μA
Vagc High Input Bias Current ($V_{agc} = 2.1V$, $V_{CC} = 5.5V$)	I_{vagc_HI}	A	25	-	10	400	μA
Vagc Low Input Bias Current ($V_{agc} = 0.7V$, $V_{CC} = 5.5V$)	I_{vagc_LO}	A	25	-400	-10	-	μA
Power Enable Time (50% V_{PE} to 90% I_{CC})	PEt	B	25	-	5	10	μs
Power Disable Time (50% V_{PE} to 10% I_{CC})	PDt	B	25	-	0.1	10	μs

NOTES:

2. Test Level: A = 100% production tested, B = Typical or Limit based on characterization data, C = Design information, goal or condition.
3. Bias Resistor at pin 16 changes according to the relationship mentioned in Note 4 of the Typical Applications Circuit.

HFA3663

Typical Application Circuit

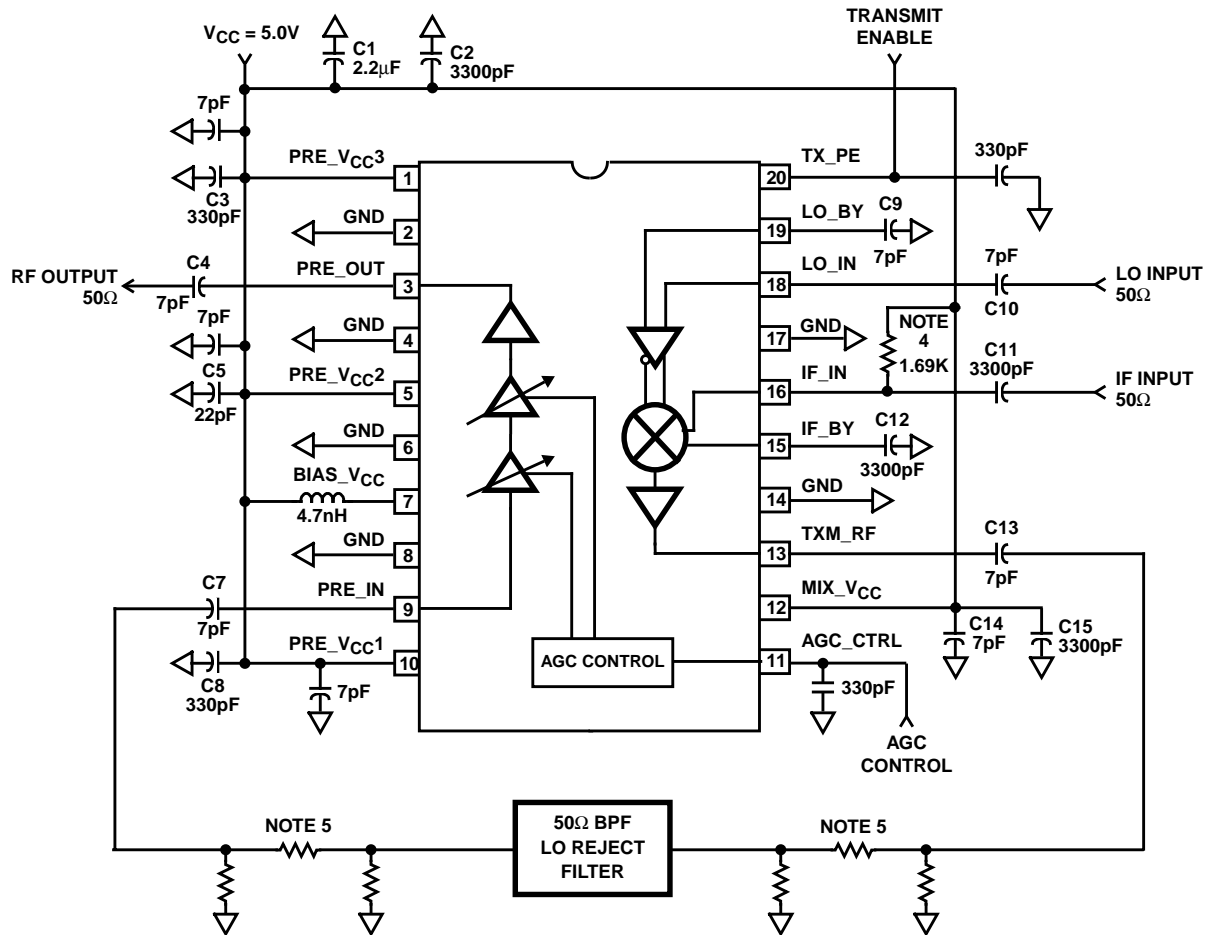

NOTES:

4. Required external resistor for Mixer biasing. Value optimized for 2.7mA bias current with $R = (V_{CC} - 0.93) / 2.7\text{mA}$. Most Mixer cell characteristics like Gain, NF etc., can be affected when biasing is outside the optimum value.
5. The combination of these attenuator pads and the Band Pass Filter insertion loss shall bring the overall Cascaded Gain at the desired frequency of operation from 21dB to 22dB for best performance. The selection of these values is optional. The total gain, LO feedthru, Mixer and Pre-amplifier interaction (stability) and output compression point performances can be manipulated according to the user needs.

All Intersil semiconductor products are manufactured, assembled and tested under **ISO9000** quality systems certification.

Intersil semiconductor products are sold by description only. Intersil Corporation reserves the right to make changes in circuit design and/or specifications at any time without notice. Accordingly, the reader is cautioned to verify that data sheets are current before placing orders. Information furnished by Intersil is believed to be accurate and reliable. However, no responsibility is assumed by Intersil or its subsidiaries for its use; nor for any infringements of patents or other rights of third parties which may result from its use. No license is granted by implication or otherwise under any patent or patent rights of Intersil or its subsidiaries.

For information regarding Intersil Corporation and its products, see web site <http://www.intersil.com>

Sales Office Headquarters

NORTH AMERICA

Intersil Corporation
P. O. Box 883, Mail Stop 53-204
Melbourne, FL 32902
TEL: (407) 724-7000
FAX: (407) 724-7240

EUROPE

Intersil SA
Mercure Center
100, Rue de la Fusee
1130 Brussels, Belgium
TEL: (32) 2.724.2111
FAX: (32) 2.724.22.05

ASIA

Intersil (Taiwan) Ltd.
7F-6, No. 101 Fu Hsing North Road
Taipei, Taiwan
Republic of China
TEL: (886) 2 2716 9310
FAX: (886) 2 2715 3029