



400MHz AGC and Quadrature IF Demodulator



The HFA3761 is a highly integrated baseband converter for quadrature demodulation applications. The HFA3761 400MHz AGC and quadrature IF demodulator is one of the seven chips in the PRISM® full duplex chip set (see Typical Application Diagram). It features all the necessary blocks for baseband demodulation of I and Q signals. It has a two stage integrated AGC IF amplifier with 82dB of voltage gain and 76dB of gain control range. Baseband antialiasing and shaping filters are integrated in the design. Four filter bandwidths are programmable via a two bit digital control interface. In addition, these filters are continuously tunable over a ±20% frequency range via one external resistor. To achieve broadband operation, the Local Oscillator frequency input is required to be twice the desired frequency of demodulation. A selectable buffered divide by 2 LO output and a stable reference voltage are provided for convenience of the user. The device is housed in a thin 80 lead TQFP package well suited for PCMCIA board applications.

Ordering Information

PART NUMBER	TEMP. RANGE (°C)	PACKAGE	PKG. NO.
HFA3761IN	-40 to 85	80 Ld TQFP	Q80.14x14

Features

- Integrates all IF and AGC Receive Functions
- Broad Frequency Range 10MHz to 400MHz
- I/Q Amplitude and Phase Balance 0.2dB, 2 Degrees
- 5th Order Programmable Low Pass Filter 2.2MHz to 17.6MHz
- 400MHz AGC Gain Strip 82dB
- AGC Range 75dB
- Low LO Drive Level -15dBm
- Fast AGC Switching 1µs
- Power Management/Standby Mode
- Single Supply 2.7V to 5.5V Operation

Applications

- Wireless Local Loop
- Wireless Local Area Networks
- PCMCIA Wireless Transceivers
- ISM Systems
- CDMA Radios
- PCS/Wireless PBX

Simplified Block Diagram

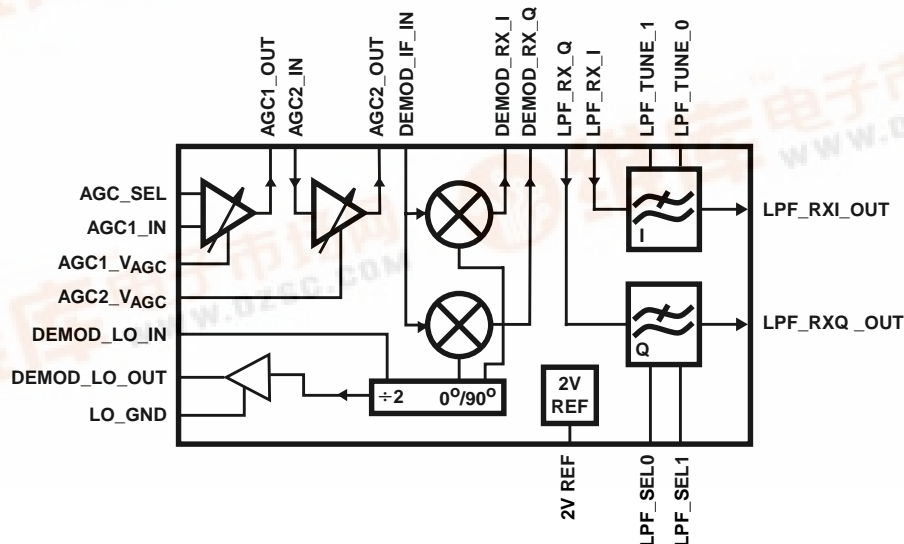

HFA3761

Block Diagram

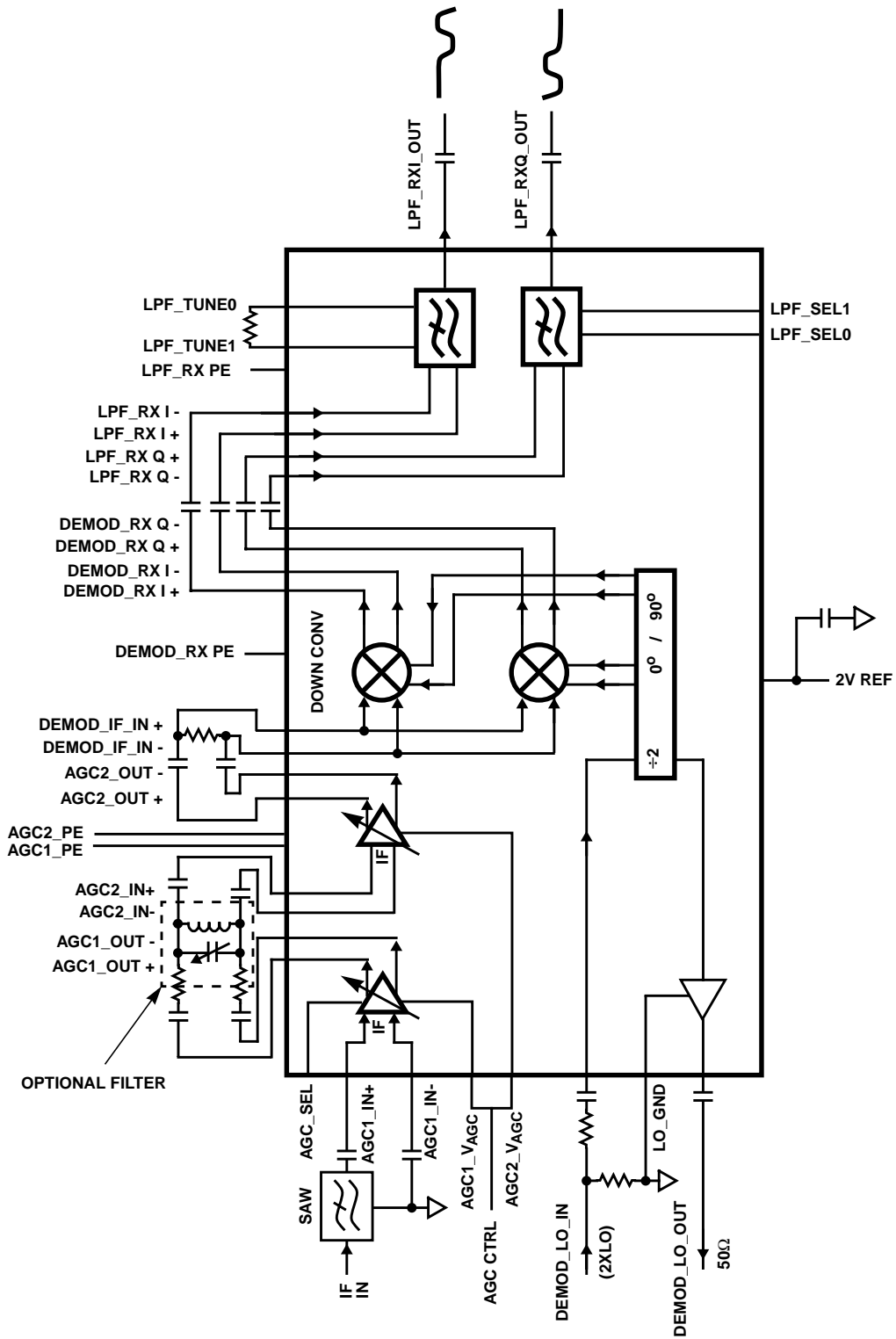

NOTE: V_{CC}, GND and Bypass capacitors not shown.

HFA3761

Pin Descriptions

PIN	SYMBOL	DESCRIPTION																		
1	AGC1_BYP+	DC feedback pin for AGC amplifier 1. Requires good decoupling and minimum wire length to a solid signal ground.																		
2	AGC1_In+	Non-inverting analog input of AGC amplifier 1.																		
3	GND	Ground. Connect to a solid ground plane.																		
4	AGC_Sel	This pin selects either differential or single ended input configuration for the first stage AGC. Ground this pin for differential input configuration. Leave it floating for single ended input configuration.																		
5,	AGC1_In-	Inverting analog input of AGC amplifier 1.																		
6,	AGC1_BYP-	DC feedback pin for AGC amplifier 1. Requires good decoupling and minimum wire length to a solid signal ground.																		
7, 8	GND	Ground. Connect to a solid ground plane.																		
9	LPF_VCC	Supply pin for the Low pass filter. Use high quality decoupling capacitors right at the pin.																		
10	2V REF	Stable 2V reference voltage output for external applications. Loading must be higher than 10kΩ. A bypass capacitor of at least 0.1μF is required.																		
11	LPF_BYP	Internal reference bypass pin. This is the common voltage (V _{CM}) used for the LPF digital thresholds. Requires 0.1μF decoupling capacitor.																		
12	NC	Connected internally for test purposes. Pin must be left floating.																		
13	NC	Connected internally for test purposes. Pin must be left floating.																		
14	LPF_RXI_Out	Low pass filter in phase (I) channel receive output. Requires AC coupling.																		
15	LPF_RXQ_Out	Low pass filter quadrature (Q) channel receive output. Requires AC coupling.																		
16	LPF_Sel1	Digital control input pins. Selects four programmed cut off frequencies for the receive channel. Tuning speed from one cutoff to another is less than 1μs.																		
17	LPF_Sel0																			
			<table style="width: 100%; border-collapse: collapse;"> <thead> <tr> <th style="text-align: left;">SEL1</th> <th style="text-align: left;">SEL0</th> <th style="text-align: left;">CUTOFF FREQUENCY</th> <th style="text-align: left;">SEL1</th> <th style="text-align: left;">SEL0</th> <th style="text-align: left;">CUTOFF FREQUENCY</th> </tr> </thead> <tbody> <tr> <td>LO</td> <td>LO</td> <td>2.2MHz</td> <td>HI</td> <td>LO</td> <td>8.8MHz</td> </tr> <tr> <td>LO</td> <td>HI</td> <td>4.4MHz</td> <td>HI</td> <td>HI</td> <td>17.6MHz</td> </tr> </tbody> </table>	SEL1	SEL0	CUTOFF FREQUENCY	SEL1	SEL0	CUTOFF FREQUENCY	LO	LO	2.2MHz	HI	LO	8.8MHz	LO	HI	4.4MHz	HI	HI
SEL1	SEL0	CUTOFF FREQUENCY	SEL1	SEL0	CUTOFF FREQUENCY															
LO	LO	2.2MHz	HI	LO	8.8MHz															
LO	HI	4.4MHz	HI	HI	17.6MHz															
18	LPF_Tune1	These two pins are used to fine tune the Low pass filter cutoff frequency. A resistor connected between the two pins (R _{TUNE}) will fine tune both transmit and receive filters. Refer to the tuning equation in the LPF AC specifications.																		
19	LPF_Tune0																			
20	GND	Ground. Connect to a solid ground plane.																		
21	LPF_RX_PE	Digital input control pin to enable the LPF receive mode of operation. Enable logic level is High.																		
22	GND	Ground. Connect to a solid ground plane.																		
23	NC	Connected internally for test purposes. Pin must be left floating.																		
24	NC	Connected internally for test purposes. Pin must be left floating.																		
25	NC	Connected internally for test purposes. Pin must be left floating.																		
26	NC	Connected internally for test purposes. Pin must be left floating.																		
27	LPF_RXQ-	Low pass filter inverting input of the receive quadrature channel. AC coupling is required. This input is normally coupled to the negative output of the quadrature demodulator (Mod_RXQ-), pin 36.																		
28	LPF_RXQ+	Low pass filter non inverting input of the receive quadrature channel. AC coupling is required. This input is normally coupled to the positive output of the quadrature demodulator (Mod_RXQ+), pin 35.																		
29	LPF_RXI-	Low pass filter inverting input of the receive in phase channel. AC coupling is required. This input is normally coupled to the negative output of the in phase demodulator (Mod_RXI-), pin 34.																		
30	LPF_RXI+	Low pass filter non inverting input of the receive in phase channel. AC coupling is required. This input is normally coupled to the positive output of the in phase demodulator (DEM0D_RXI-), pin 33.																		
31, 32	GND	Ground. Connect to a solid ground plane.																		
33	DEM0D_RXI+	In phase demodulator positive output. AC coupling is required. Normally connects to the non inverting input of the Low pass filter (LPF_RXI+), pin 30.																		
34	DEM0D_RXI-	In phase demodulator negative output. AC coupling is required. Normally connects to the inverting input of the Low pass filter (LPF_RXI-), pin 29.																		

HFA3761

Pin Descriptions (Continued)

PIN	SYMBOL	DESCRIPTION
35	DEM0D_RXQ+	Quadrature demodulator positive output. AC coupling is required. Normally connects to the non inverting input of the Low pass filter (LPF_RXQ+), pin 28.
36	DEM0D_RXQ-	Quadrature demodulator negative output. AC coupling is required. Normally connects to the inverting input of the Low pass filter (LPF_RXQ+), pin 27.
37	NC	Connected internally for test purposes. Pin must be left floating.
38	NC	Connected internally for test purposes. Pin must be left floating.
39	NC	Connected internally for test purposes. Pin must be left floating.
40	NC	Connected internally for test purposes. Pin must be left floating.
41	GND	Ground. Connect to a solid ground plane.
42	DEM0D_VCC	Supply pin for the Demodulator. Use high quality decoupling capacitors right at the pin.
43	DEM_RX_PE	Digital input control to enable the demodulator section. Enable logic level is High.
44	DEM_LO_In (2XLO)	Single ended local oscillator current input. Frequency of input signal must be twice the required demodulator LO frequency. Input current is optimum at 200 μ A _{RMS} . Input matching networks and filters can be designed for a wide range of power and impedances at this port. Typical input impedance is 130 Ω . This pin requires AC coupling. NOTE: High second harmonic content input waveforms may degrade I/Q phase accuracy.
45	DEM0D_VCC	Supply pin for the Demodulator. Use high quality decoupling capacitors right at the pin.
46	DEM_LO_Out	Divide by 2 buffered output reference from "DEM0D_LO_in" input. Used for external applications where the demodulating carrier reference frequency is required. 50 Ω single end driving capability. This output can be disabled by use of pin 50. AC coupling is required.
47	DEM0D_VCC	Supply pin for the Demodulator. Use high quality decoupling capacitors right at the pin.
48	DEM0D_IFIN+	Demodulator, non-inverting input. Requires AC coupling.
49	DEM0D_IFIN-	Demodulator, inverting input. Requires AC coupling.
50	LO_GND	When grounded, this pin enables the LO buffer (DEM0D_LO_Out). When open (NC) it disables the LO buffer.
51, 52, 53	GND	Ground. Connect to a solid ground plane.
54	AGC2_VCC	Supply pin for the AGC amplifier 2. Use high quality decoupling capacitors right at the pin.
55	AGC2_Out-	Positive output of AGC amplifier 2. Requires AC coupling.
56	AGC2_Out+	Negative output of AGC amplifier 2. Requires AC coupling.
57	AGC2_PE	Digital input control to enable the AGC amplifier 2. Enable logic level is High.
58	AGC2_VCC	Supply pin for the AGC amplifier 2. Use high quality decoupling capacitors right at the pin.
59	GND	Ground. Connect to a solid ground plane.
60	AGC2_VAGC	AGC amplifier 2, AGC control input.
61	AGC2_BYP+	DC feedback pin for AGC amplifier 2. Requires good decoupling and minimum wire length to a solid signal ground.
62	AGC2_In+	Non-inverting analog input of AGC amplifier 2.
63	GND	Ground. Connect to a solid ground plane.
64	AGC2_In-	Inverting input of AGC amplifier 2.
65	AGC2_BYP-	DC feedback pin for AGC amplifier 2. Requires good decoupling and minimum wire length to a solid signal ground.
66 - 73	GND	Ground. Connect to a solid ground plane.
74	AGC1_VCC	AGC amplifier 1 supply pin. Use high quality decoupling capacitors right at the pin.
75	AGC1_Out-	Negative output of AGC amplifier 1. Requires AC coupling.
76	AGC1_Out+	Positive output of AGC amplifier 1. Requires AC coupling.
77	AGC1_PE	Digital input control to enable the AGC amplifier 1. Enable logic level is High.
78	AGC1_VCC	AGC amplifier 1 supply pin. Use high quality decoupling capacitors right at the pin.
79	GND	Ground. Connect to a solid ground plane.
80	AGC1_VAGC	AGC amplifier 1, AGC control input.

HFA3761

Absolute Maximum Ratings

Supply Voltage -0.3V to +6.0V
 Voltage on Any Other Pin -0.3V to $V_{CC} + 0.3V$

Operating Conditions

Supply Voltage Range 2.7 to 5.5V
 Operating Temperature Range $-40^{\circ}C \leq T_A \leq 85^{\circ}C$

Thermal Information

Thermal Resistance (Typical, Note 1) θ_{JA} ($^{\circ}C/W$)
 TQFP Package 75
 Package Power Dissipation at $70^{\circ}C$
 TQFP Package 1.1W
 Maximum Junction Temperature (Plastic Package) $150^{\circ}C$
 Maximum Storage Temperature Range $-65^{\circ}C \leq T_A \leq 150^{\circ}C$
 Maximum Lead Temperature (Soldering 10s) $300^{\circ}C$
 (TQFP - Lead Tips Only)

CAUTION: Stresses above those listed in "Absolute Maximum Ratings" may cause permanent damage to the device. This is a stress only rating and operation of the device at these or any other conditions above those indicated in the operational sections of this specification is not implied.

NOTE:

1. θ_{JA} is measured with the component mounted on an evaluation PC board in free air.

Cascaded DC Electrical Specifications $V_{CC} = 4.5V$ to $5.5V$, Unless Otherwise Specified

PARAMETER	(NOTE 2) TEST LEVEL	TEMP ($^{\circ}C$)	MIN	TYP	MAX	UNITS
Total Supply Current, at 5.5V	A	Full	-	80	112	mA
Shutdown (Standby) Current at 5.5V	A	Full	-	.8	1.5	mA
All Digital Inputs V_{IH} (TTL Threshold for All V_{CC})	A	Full	2.0	-	V_{CC}	V
All Digital Inputs V_{IL} (TTL Threshold for All V_{CC})	A	Full	-0.2	-	0.8	V
High Level Input Current at 5.5V V_{CC} for pins 16 and 21 with $V_{IN} = 2.4V$	A	Full	-200	-65	0	μA
High Level Input Current at 5.5V V_{CC} for pins 16 and 21 with $V_{IN} = 4.0V$	A	Full	-150	-30	0	μA
Low Level Input Current at 5.5V V_{CC} for pins 16 and 21 with $V_{IN} = 0.8V$	A	Full	-300	-95	0	μA
High Level Input Current at 5.5V V_{CC} for pin 17, with $V_{IN} = 2.4V$	A	Full	0	50	200	μA
High Level Input Current at 5.5V V_{CC} for pin 17, with $V_{IN} = 4.0V$	A	Full	0	80	300	μA
Low Level Input Current at 5.5V V_{CC} for pin 17, with $V_{IN} = 0.8V$	A	Full	0	15	150	μA
High Level Input Current at 5.5V V_{CC} for pin 43 with $V_{IN} = 2.4V$	A	Full	-20	1	20	μA
High Level Input Current at 5.5V V_{CC} for pin 43 with $V_{IN} = 4.0V$	A	Full	0	110	300	μA
Low Level Input Current at 5.5V V_{CC} for pin 43 with $V_{IN} = 0.8V$	A	Full	-20	.1	20	μA
V_{AGC} Input for Max Gain (Note 5)	A	25	.8	1.1	-	V
V_{AGC} Input for Min Gain (Note 5)	A	25	-	2.1	2.2	V
V_{AGC} Control Input Impedance (Per Stage) (Note 3)	C	25	-	410	-	Ω
V_{AGC} Control Input Current (Per Stage) at Max Control Voltage	A	25	-	.5	2.0	mA
Full Range AGC Switching Large Signal Recovery (Note 4)	B	25	-	400	-	ns
Full Range AGC Switching 1dB Settling Time (Note 4)	B	25	-	1.5	-	μs
Power Down/Up Switching Speed (Note 4)	B	25	-	2	-	μs
Reference Voltage	A	Full	1.85	2.0	2.15	V
Reference Voltage Variation Over Temperature	B	25	-	800	-	$\mu V/^{\circ}C$
Reference Voltage Variation Over Supply Voltage	B	25	-	1.6	-	mV/V
Reference Voltage Minimum Load Resistance	C	25	10	-	-	k Ω

NOTES:

2. A = Production Tested, B = Based on Characterization, C = By Design.
3. 1.2V reference source in series with 410 Ω .
4. Determined by external components.
5. Measured at probe.

HFA3761

Cascaded AC Electrical Specifications, Demodulator Chain Performance $V_{CC} = 4.5\text{V}$ to 5.5V , LO = 560 MHz, and IF=280 MHz, Unless Otherwise Specified

PARAMETER	(NOTE 6) TEST LEVEL	TEMP. (°C)	MIN	TYP	MAX	UNITS
IF Demodulator I and Q Outputs Voltage Swing (IF input Range of -70 dBm to -30 dBm)	A	Full	250	-	-	mV _{p-p}
IF Demodulator I and Q Channels Output Drive Capability ($Z_{OUT} = 50\Omega$, $C_{MAX} = 10\text{pF}$, $V_{OUT} = 500\text{mV}_{p-p}$)	C	25	1.2	2	-	k Ω
IF Demodulator I/Q Amplitude Balance, IFin = -70dBm at 50 Ω	A	Full	-1.0	0	+1.0	dB
IF Demodulator I/Q Phase Balance, IFin = -70dBm at 50 Ω	A	Full	-4.0	0	+4.0	Degrees
IF Demodulator Output, P1dB	TBD	TBD	TBD	TBD	TBD	mV

NOTES:

- 6. A = Production Tested, B = Based on Characterization, C = By Design.
- 7. Determined by external components.

AC Electrical Specifications, Cascaded AGC Stages Performance $V_{CC} = 4.5\text{V}$ to 5.5V

PARAMETER	(NOTE 8) TEST LEVEL	TEMP. (°C)	MIN	TYP	MAX	UNITS
Frequency Range (Note 9)	B	25	10	-	400	MHz
Voltage Gain at Max Gain (Note 10) ($V_{AGC} = 0.8\text{V}$, $R_S = 50\Omega$, $R_L = 500\Omega$)	A	25	78	82	-	dB
Voltage Gain at Min Gain ($V_{AGC} = 2.1\text{V}$, $R_S = 50\Omega$, $R_L = 500\Omega$)	B	25	-	7	-	dB
Noise Figure at Max Gain, $R_S = 50\Omega$	B	25	-	10	11	dB
Output P 1dB at Min Gain, $R_S = 50\Omega$, dBm into $R_L = 500\Omega$	B	25	-16	-13	-	dBm
Input P 1dB at Min Gain, $R_S = 50\Omega$	B	25	-13	-10	-	dBm
Output IP3 at Min Gain, dBm into $R_L = 500\Omega$	B	25	-5	-2	-	dBm
Input IP3 at Min Gain, $R_S = 50\Omega$	B	25	-2	1	-	dBm
Group Delay, 20MHz Bandwidth	B	25	-	2.0	-	ns _{p-p}
Single Ended Input Impedance, AGC_SEL = floating	B	25	-	50	-	Ω
Differential Input Impedance, AGC_SEL = ground	B	25	-	100	-	Ω
Differential Output Impedance	B	25	-	80	-	Ω

NOTES:

- 8. A = Production Tested, B = Based on Characterization, C = By Design.
- 9. Determined by external components.
- 10. Measured at probe.

AC Electrical Specifications, I/Q Down Converter Individual Performance $V_{CC} = 4.5\text{V}$ to 5.5V

PARAMETER	(NOTE 11) TEST LEVEL	TEMP. (°C)	MIN	TYP	MAX	UNITS
Quadrature Demodulator Input Frequency Range	B	25	10	-	400	MHz
Demodulator Baseband I/Q Frequency Range	C	25	-	-	30	MHz
Demodulator Voltage Gain Over Frequency Range	B	25	6	8	9	dB
Demodulator Differential Input Resistance	C	25	-	1	-	k Ω
Demodulator Differential Input Capacitance	C	25	-	0.5	-	pF

HFA3761

AC Electrical Specifications, I/Q Down Converter Individual Performance $V_{CC} = 4.5V$ to $5.5V$ (Continued)

PARAMETER	(NOTE 11) TEST LEVEL	TEMP. (°C)	MIN	TYP	MAX	UNITS
Demodulator Differential Output Level at 4K Load, (Output Controlled By AGC Action)	B	25	400	500	560	mV _{P-P}
Demodulator Amplitude Balance	A	25	-1.0	-	1.0	dB
Demodulator Phase Balance at 286MHz	A	25	-4	-	4	Degrees
Demodulator Phase Balance at 400MHz	B	25	-4	-	4	Degrees
Demodulator Output 1dB Compression Voltage at 4K Load	B	25	-	1.25	-	V _{P-P}

NOTE:

11. A = Production Tested, B = Based on Characterization, C = By Design.

AC Electrical Specifications, LO Individual Performance $V_{CC} = 4.5V$ to $5.5V$

PARAMETER	(NOTE 12) TEST LEVEL	TEMP. (°C)	MIN	TYP	MAX	UNITS
2XLO Input Frequency Range (2 X Input Range)	B	25	20	-	800	MHz
2XLO Input Current Range	C	25	50	200	300	μA _{RMS}
2XLO Input Impedance	C	25	-	130	-	Ω
Buffered LO Output Voltage, Single Ended	C	25	50	100	-	mV _{P-P}
Buffered LO Output Impedance	C	25	-	50	-	Ω

NOTE:

12. A = Production Tested, B = Based on Characterization, C = By Design.

AC Electrical Specifications, RX 5TH Order LPF Individual Performance $V_{CC} = 4.5V$ to $5.5V$

PARAMETER	(NOTE 13) TEST LEVEL	TEMP. (°C)	MIN	TYP	MAX	UNITS
RX LPF 3dB Bandwidth, Sel0 = 0, Sel1 = 0	A	25	1.8	2.20	2.4	MHz
RX LPF 3dB Bandwidth, Sel0 = 1, Sel1 = 0	A	25	3.6	4.40	4.8	MHz
RX LPF 3dB Bandwidth, Sel0 = 0, Sel1 = 1	A	25	7.4	8.80	9.6	MHz
RX LPF 3dB Bandwidth, Sel0 = 1, Sel1 = 1	A	25	14.8	17.60	19.2	MHz
RX LPF Sel0, Sel1 Tuning Speed	B	25	-	-	1	μs
RX LPF 3dB Bandwidth Tuning	A	25	-20	-	+20	%
LPF Tune Nominal Resistance	B	25	-	787	-	Ω
RX LPF Voltage Gain	A	25	-1.0	0	1.0	dB
RX LPF Single Ended Output Voltage Swing at 2kΩ Load (Controlled By AGC Action)	B	25	-	-	550	mV _{P-P}
RX LPF Differential Input Impedance	A	25	4	5	-	kΩ
RX I/Q Channel Amplitude Match	A	Full	-1	-	1	dB
RX I/Q Channel Phase Match	A	Full	-4	-	4	Degrees
RX LPF Total Harmonic Distortion	B	25	-	3	6	%
LPF Output Impedance, Single-Ended	C	25	-	50	-	Ω

NOTE:

13. A = Production Tested, B = Based on Characterization, C = By Design.

HFA3761

TABLE 1. LOW PASS FILTER PROGRAMING AND TUNING INFORMATION

MODE	LPF SEL1	LPF SEL0	f _{3dB} (NOMINAL R _{TUNE})
BW0	0	0	2.2MHz
BW1	0	1	4.4MHz
BW2	1	0	8.8MHz
BW3	1	1	17.6MHz

$$f_{\text{TUNED } 3\text{dB}} = \frac{f_{3\text{dB NOMINAL}} * 787}{R_{\text{TUNE}}}$$

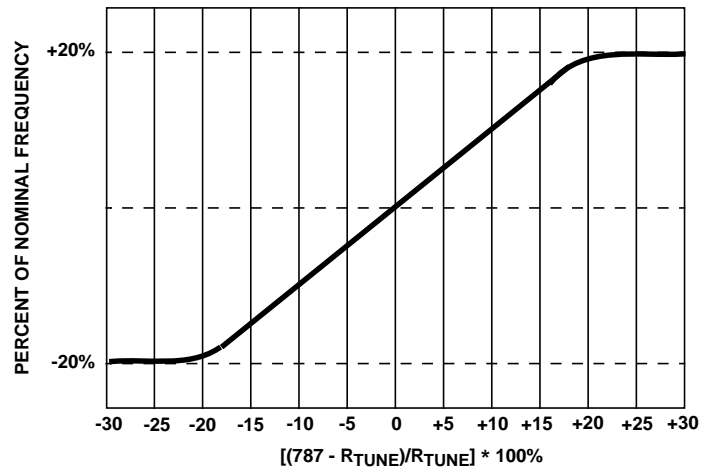

FREQUENCY	R _{TUNE}
20% Low	984Ω
Nominal	787Ω
20% High	656Ω

FIGURE 1. TYPICAL f_{3dB} vs R_{TUNE}