

Ceramic High Pass Filter

NEW!
HFCN-2100

2500 to 6000 MHz

Maximum Ratings

Operating Temperature	-55°C to 100°C
Storage Temperature	-55°C to 100°C
RF Power Input*	7W max. at 25°C

*Passband rating, derate linearly to 3W at 100°C ambient.

Pin Connections

RF IN	1**
RF OUT	3**
GROUND	2,4

** RF IN & RF OUT can be interchanged

Outline Drawing

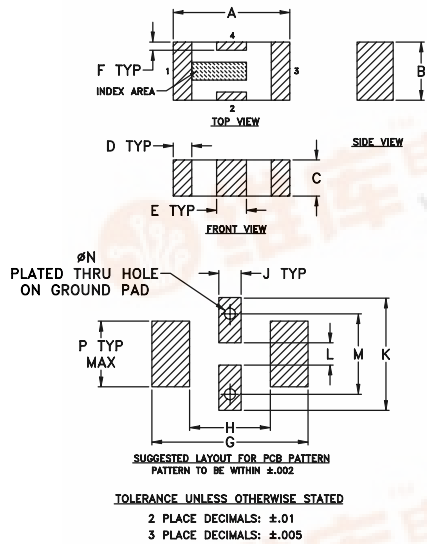

Outline Dimensions (inch/mm)

A	B	C	D	E	F	G
.126	.063	.037	.020	.032	.009	.169
3.20	1.60	0.94	0.51	0.81	0.23	4.29

H	J	K	L	M	N	P	wt
.087	.024	.122	.024	.087	.012	.071	grams
2.21	0.61	3.10	0.61	2.21	0.30	1.80	.020

Demo Board MCL P/N: TB-270
Suggested PCB Layout (PL-137)

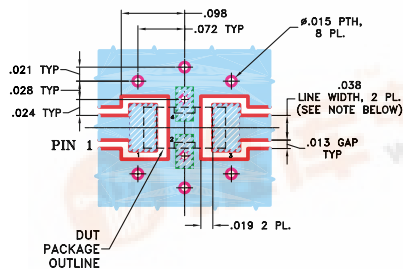

NOTE: 1. TRACE WIDTH IS SHOWN FOR ROGERS RO4350 WITH DIELECTRIC THICKNESS .020" ± .0015". COPPER: 1/2 OZ. EACH SIDE. FOR OTHER MATERIALS TRACE WIDTH MAY NEED TO BE MODIFIED.
2. BOTTOM SIDE OF THE PCB IS CONTINUOUS GROUND PLANE.

① DENOTES PCB COPPER LAYOUT
② DENOTES COPPER LAND PATTERN FREE OF SOLDERMASK

Features

- low cost
- small size
- 7 sections
- temperature stable
- excellent power handling, 7W

Applications

- sub-harmonic rejection
- transmitters/receivers
- lab use



BLUE CELL™

CASE STYLE: FV1206

Model	Price	Qty.
HFCN-2100	\$1.99	(10-49)
HFCN-2100D	\$2.49	(10-49)

High Pass Filter Electrical Specifications¹ (T_{AMB}=25°C)

MODEL NO.	STOP BAND (MHz)		f _{co} , MHz Nom. Typ.	PASSBAND (MHz)		VSWR Typ. Frequency (MHz) 1.5:1	POWER INPUT (W)	NO. OF SECTIONS
	(loss>40 dB)	(loss>20 dB)		(loss<1.3 dB) Max.	(loss<2 dB) Typ.			
HFCN-2100	1050	1530	2100	2500-5000	2200-6000	20:1	2400-5200	7

1. For Applications requiring DC voltage to be applied to the Input or output, use HFCN-2100D (DC Resistance to ground is 100 Mohms min.)

typical frequency response

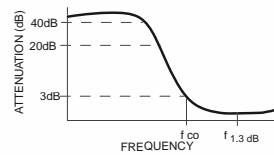

schematic

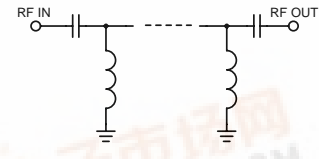

Typical Performance Data at 25°C

Frequency (MHz)	Insertion Loss (dB)	VSWR (:1)
1.00	87.12	>20
500.00	57.51	>20
1200.00	57.51	>20
1530.00	27.57	>20
1800.00	14.13	>20
2100.00	2.96	2.96
2500.00	0.86	1.29
3000.00	0.77	1.45
4000.00	0.67	1.39
5000.00	0.70	1.28
5681.00	1.24	1.82
6000.00	1.55	2.14
7000.00	2.69	3.34
8000.00	3.65	4.67
9000.00	4.72	6.30

