

GENERAL DESCRIPTION

The HI-3182, HI-3183, HI-3184, HI-3185, HI-3186, HI-3187 and HI-3188 bus interface products are silicon gate CMOS devices designed as a line driver in accordance with the ARINC 429 bus specifications. In addition to being functional upgrades of Holt's HI-8382 & HI-8383 products, they are also alternate sources for the HS-3182 (Intersil/Harris), the RM3182 (Fairchild/Raytheon) and a variety of similar DEI/DDC line driver products.

Inputs are provided for clocking and synchronization. These signals are AND'd with the DATA inputs to enhance system performance and allow the HI-318X series of products to be used in a variety of applications. Both logic and synchronization inputs feature built-in 2,000V minimum ESD input protection as well as TTL and CMOS compatibility.

The differential outputs of the HI-318X series of products are independently programmable to either the high speed or low speed ARINC 429 output rise and fall time specifications through the use of two external capacitors. The output voltage swing is also adjustable by the application of an external voltage to the VREF input. Products with 0, 13 or 37.5 ohm resistors in series with each ARINC output are available. In addition, the HI-3182, HI-3184 and HI-3187 products also have a fuse in series with each output.

The HI-318X series of line drivers are intended for use where logic signals must be converted to ARINC 429 levels such as when using an ASIC, the HI-8282 ARINC 429 Serial Transmitter/Dual Receiver, the HI-6010 ARINC 429 Transmitter/Receiver or the HI-8783 ARINC Interface Device. Holt products are readily available for both industrial and military applications. Please contact the Holt Sales Department for additional information.

FEATURES

- Low power CMOS
- TTL and CMOS compatible inputs
- Programmable output voltage swing
- Adjustable ARINC rise and fall times
- Plastic 14 & 16-pin thermally enhanced SOIC packages available
- Pin-for-Pin alternative for DEI/DDC/Intersil/Fairchild applications
- Operates at data rates up to 100 Kbits
- Overvoltage protection

Industrial and Military temperature ranges

PIN CONFIGURATION (Top View)

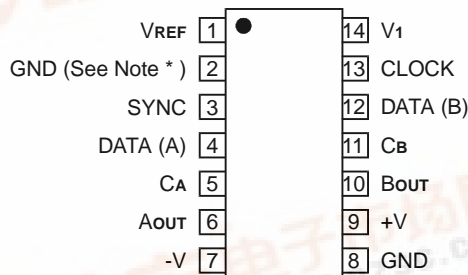

HI-3184PS, HI-3185PS, HI-3186PS & HI-3187PS

14 - PIN PLASTIC SMALL OUTLINE (ESQIC)**

Notes: * Pin 2 may be left floating
** Thermally Enhanced SOIC Package

(See Page 5 for additional package pin configurations)

FUNCTION

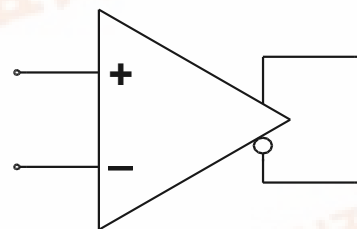

ARINC 429 DIFFERENTIAL LINE DRIVER

TRUTH TABLE

SYNC	CLOCK	DATA(A)	DATA(B)	AOUT	BOUT	COMMENTS
X	L	X	X	0V	0V	NULL
L	X	X	X	0V	0V	NULL
H	H	L	L	0V	0V	NULL
H	H	L	H	-VREF	+VREF	LOW
H	H	H	L	+VREF	-VREF	HIGH
H	H	H	H	0V	0V	NULL



HI-3182, HI-3183, HI-3184, HI-3185, HI-3186, HI-3187, HI-3188

FUNCTIONAL DESCRIPTION

The SYNC and CLOCK inputs establish data synchronization utilizing two AND gates, one for each data input. Each logic input, including the power enable (STROBE) input, are TTL/CMOS compatible.

Figure 1 illustrates a typical ARINC 429 bus application. Three power supplies are necessary to operate the HI-3182; typically +15V, -15V and +5V. The chip also works with $\pm 12V$ supplies. The +5V supply can also provide a reference voltage that determines the output voltage swing. The differential output voltage swing will equal $2V_{REF}$. If a value of V_{REF} other than +5V is needed, a separate +5V power supply is required for pin V1.

With the DATA (A) input at a logic high and DATA (B) input at a logic low, AOUT will switch to the +VREF rail and BOUT will switch to the -VREF rail (ARINC HIGH state). With both data input signals at a logic low state, the outputs will both switch to 0V (ARINC NULL state).

The driver output impedance, R_{OUT} , is nominally 75, 26 or 0 ohms depending on the option chosen. The rise and fall times of the outputs can be calibrated through the selection of two external capacitor values that are connected to the CA and CB input pins. Typical values for high-speed operation (100KBPS) are $C_A = C_B = 75pF$ and for low-speed operation (12.5 to 14KBPS) $C_A = C_B = 500pF$.

The CA and CB pins swing between +5V and ground allowing the switching of capacitor values with an external single-supply analog switch.

The ARINC outputs can be put in a tri-state mode by applying a logic high to the STROBE input pin. If this feature is not being used, the pin should be tied to ground. The STROBE function is not available in the 14 & 16-pin SOIC package configurations where the pin is internally connected to ground.

The ARINC outputs of the HI-3182, HI-3184 and HI-3187 are protected by internal fuses capable of sinking between 800 - 900 mA for short periods of time (125 μ s).

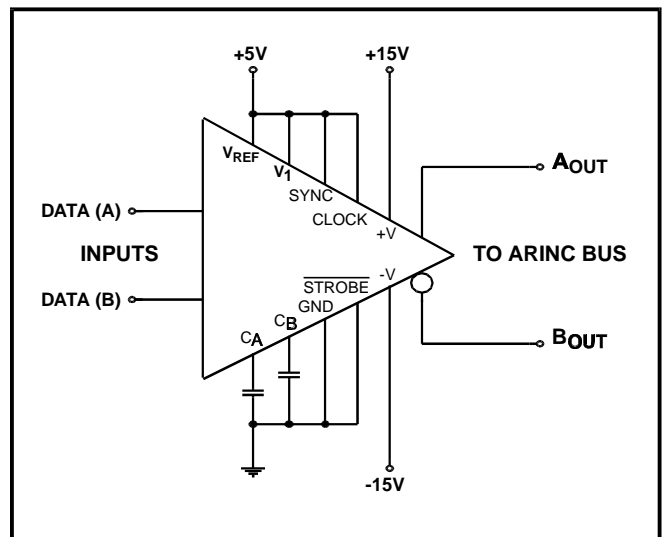

Figure 1. ARINC 429 BUS APPLICATION

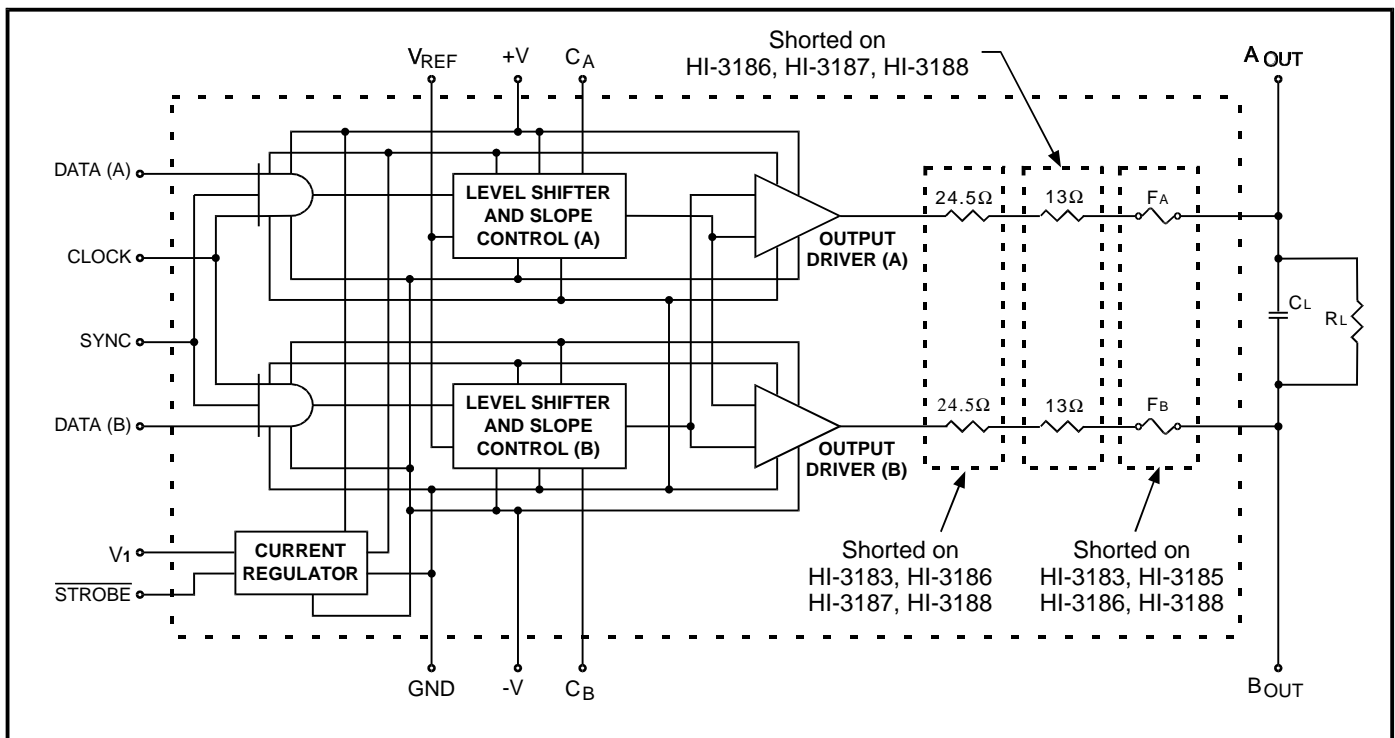

Figure 2. FUNCTIONAL BLOCK DIAGRAM

HI-3182, HI-3183, HI-3184, HI-3185, HI-3186, HI-3187, HI-3188

PIN DESCRIPTIONS

SYMBOL	FUNCTION	DESCRIPTION
V _{REF}	POWER	Reference voltage used to determine the output voltage swing
$\overline{\text{STROBE}}$	INPUT	A logic high tri-states the ARINC outputs. Not available in the 14-pin SOIC package (tied to GND internally).
SYNC	INPUT	Synchronizes data inputs
DATA (A)	INPUT	Data input terminal A
C _A	INPUT	Connection for DATA (A) slew-rate capacitor
A _{OUT}	OUTPUT	ARINC output terminal A
-V	POWER	-12V to -15V
GND	POWER	0.0V
+V	POWER	+12V to +15V
B _{OUT}	OUTPUT	ARINC output terminal B
C _B	INPUT	Connection for DATA (B) slew-rate capacitor
DATA (B)	INPUT	Data input terminal B
CLOCK	INPUT	Synchronizes data inputs
V ₁	POWER	+5V \pm 5%

ABSOLUTE MAXIMUM RATINGS

All Voltages referenced to GND, T_A = Operating Temperature Range (unless otherwise specified)

PARAMETER	SYMBOL	CONDITIONS	OPERATING RANGE	MAXIMUM	UNIT
Differential Voltage	V _{DIF}	Voltage between +V and -V terminals		40	V
Supply Voltage	+V -V V ₁		+10.8 to +16.5 -10.8 to -16.5 +5 \pm 10%	+7	V V V
Voltage Reference	V _{REF}	For ARINC 429 For Applications other than ARINC	+5 \pm 5% 0 to 6	6 6	V V
Input Voltage Range	V _{IN}			\geq GND -0.3 \leq V ₁ +0.3	V V
Output Short-Circuit Duration		See Note: 1			
Output Overvoltage Protection		See Note: 2			
Operating Temperature Range	T _A	Hi-temp & Military Industrial	-55 to +125 -40 to +85		$^{\circ}$ C $^{\circ}$ C
Storage Temperature Range	T _{STG}	Ceramic & Plastic	-65 to +150		$^{\circ}$ C
Lead Temperature		Soldering, 10 seconds		+275	$^{\circ}$ C
Junction Temperature	T _J			+175	$^{\circ}$ C

Note 1. Heatsinking may be required for Output Short Circuit at +125 $^{\circ}$ C and for 100KBPS at +125 $^{\circ}$ C.
 Note 2. The fuses used for Output Overvoltage Protection may be blown by the presence of a voltage at either output that is greater than \pm 12.0V with respect to GND. (HI-3182, 3184 & 3187 only)

NOTE: Stresses above those listed under "Absolute Maximum Ratings" may cause permanent damage to the device. These are stress ratings only. Functional operation of the device at these or any other conditions above those indicated in the operational sections of the specifications is not implied. Exposure to absolute maximum rating conditions for extended periods may affect device reliability.

HI-3182, HI-3183, HI-3184, HI-3185, HI-3186, HI-3187, HI-3188

DC ELECTRICAL CHARACTERISTICS

+V = +15V, -V = -15V, V₁ = V_{REF} = +5.0V, T_A = Operating Temperature Range (unless otherwise specified).

PARAMETER	SYMBOL	CONDITION	MIN	TYP	MAX	UNITS
Supply Current +V (Operating)	ICCOP (+V)	No Load (0 - 100KBPS)			+16	mA
Supply Current -V (Operating)	ICCOP (-V)	No Load (0 - 100KBPS)	-16			mA
Supply Current V ₁ (Operating)	ICCOP (V ₁)	No Load (0 - 100KBPS)			500	μA
Supply Current V _{REF} (Operating)	ICCOP (V _{REF})	No Load, V _{REF} = 5V (0 - 100KBPS)	-1.0			mA
Supply Current +V (During Short Circuit Test)	I _{SC} (+V)	Short to Ground (See Note: 1)			150	mA
Supply Current -V (During Short Circuit Test)	I _{SC} (-V)	Short to Ground (See Note: 1)	-150			mA
Output Short Circuit Current (Output High)	I _{OHSC}	Short to Ground V _{MIN} =0 (See Note: 2)			-80	mA
Output Short Circuit Current (Output Low)	I _{OLSC}	Short to Ground V _{MIN} =0 (See Note: 2)	+80			mA
Input Current (Input High)	I _{IH}				1.0	μA
Input Current (Input Low)	I _{IL}		-1.0			μA
Input Voltage High	V _{IH}		2.0			V
Input Voltage Low	V _{IL}				0.5	V
Output Voltage High (Output to Ground)	V _{OH}	No Load (0 -100KBPS)	+V _{REF} -0.25		+V _{REF} +0.25	V
Output Voltage Low (Output to Ground)	V _{OL}	No Load (0 -100KBPS)	-V _{REF} -0.25		-V _{REF} +0.25	V
Output Voltage Null	V _{NULL}	No Load (0-100KBPS)	-250		+250	mV
Input Capacitance	C _{IN}	See Note 1		15		pF

Note 1. Not tested, but characterized at initial device design and after major process and/or design change which affects this parameter.

Note 2. Interchangeability of force and sense is acceptable.

AC ELECTRICAL CHARACTERISTICS

+V = +15V, -V = -15V, V₁ = V_{REF} = +5.0V, T_A = Operating Temperature Range (unless otherwise specified).

PARAMETER	SYMBOL	CONDITION	MIN	TYP	MAX	UNITS
Rise Time (A _{OUT} , B _{OUT})	t _R	C _A = C _B = 75pF See Figure 3.	1.0		2.0	μs
Fall Time (A _{OUT} , B _{OUT})	t _F	C _A = C _B = 75pF See Figure 3.	1.0		2.0	μs
Propagation Delay Input to Output	t _{PLH}	C _A = C _B = 75pF See Figure 3.			3.0	μs
Propagation Delay Input to Output	t _{PHL}	C _A = C _B = 75pF See Figure 3.			3.0	μs

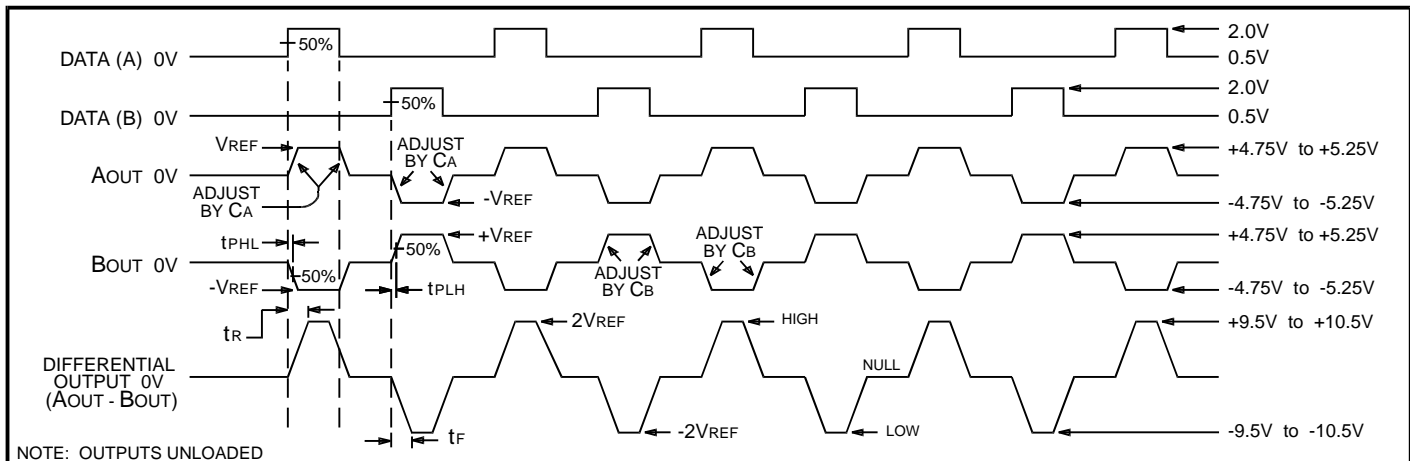
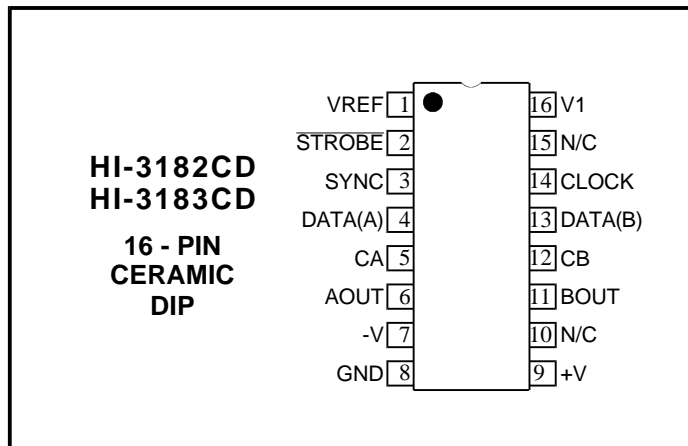
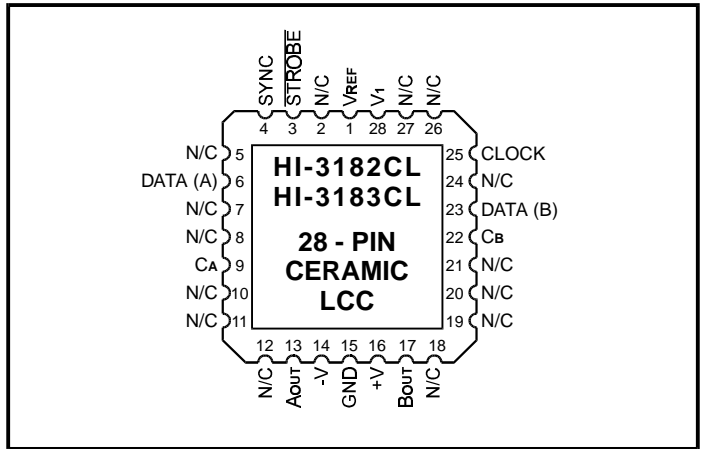
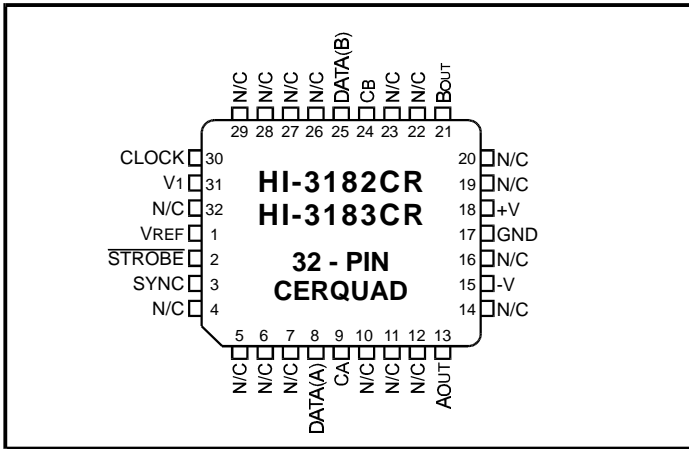
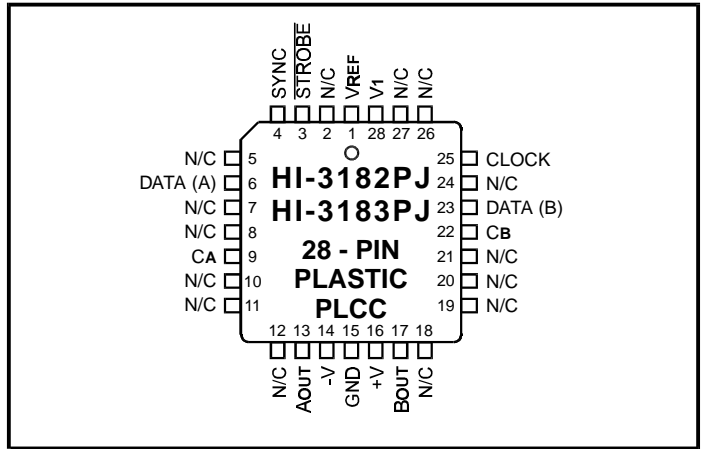
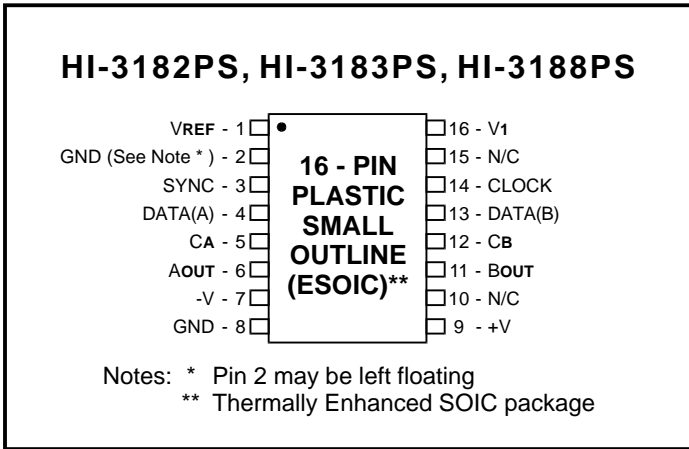

Figure 3. SWITCHING WAVEFORMS

HI-3182, HI-3183, HI-3184, HI-3185, HI-3186, HI-3187, HI-3188

ADDITIONAL PIN CONFIGURATIONS (See page 1 for 14-Pin Small Outline SOIC)



HI-3182, HI-3183, HI-3184, HI-3185, HI-3186, HI-3187, HI-3188

ORDERING INFORMATION

PART NUMBER	PACKAGE DESCRIPTION	TEMPERATURE RANGE	OUTPUT SERIES		FLOW	BURN IN	LEAD FINISH
			RESISTANCE	FUSE			
HI-3182CDI	16 PIN CERAMIC SIDE BRAZED DIP	-40°C TO +85°C	37.5	YES	I	NO	GOLD
HI-3182CDT	16 PIN CERAMIC SIDE BRAZED DIP	-55°C TO +125°C	37.5	YES	T	NO	GOLD
HI-3182CDM	16 PIN CERAMIC SIDE BRAZED DIP	-55°C TO +125°C	37.5	YES	M	YES	SOLDER
HI-3182CLI	28 PIN CERAMIC LEADLESS CHIP CARRIER (LCC)	-40°C TO +85°C	37.5	YES	I	NO	GOLD
HI-3182CLT	28 PIN CERAMIC LEADLESS CHIP CARRIER (LCC)	-55°C TO +125°C	37.5	YES	T	NO	GOLD
HI-3182CLM	28 PIN CERAMIC LEADLESS CHIP CARRIER (LCC)	-55°C TO +125°C	37.5	YES	M	YES	SOLDER
HI-3182CRI	32 PIN J-LEAD CERQUAD	-40°C TO +85°C	37.5	YES	I	NO	SOLDER
HI-3182CRT	32 PIN J-LEAD CERQUAD	-55°C TO +125°C	37.5	YES	T	NO	SOLDER
HI-3182PJI	28 PIN PLASTIC J - LEAD PLCC	-40°C TO +85°C	37.5	YES	I	NO	SOLDER
HI-3182PJT	28 PIN PLASTIC J - LEAD PLCC	-55°C TO +125°C	37.5	YES	T	NO	SOLDER
HI-3182PSI	16 PIN PLASTIC SMALL OUTLINE - WB (ESOIC)	-40°C TO +85°C	37.5	YES	I	NO	SOLDER
HI-3182PST	16 PIN PLASTIC SMALL OUTLINE - WB (ESOIC)	-55°C TO +125°C	37.5	YES	T	NO	SOLDER
HI-3183CDI	16 PIN CERAMIC SIDE BRAZED DIP	-40°C TO +85°C	13	NO	I	NO	GOLD
HI-3183CDT	16 PIN CERAMIC SIDE BRAZED DIP	-55°C TO +125°C	13	NO	T	NO	GOLD
HI-3183CDM	16 PIN CERAMIC SIDE BRAZED DIP	-55°C TO +125°C	13	NO	M	YES	SOLDER
HI-3183CLI	28 PIN CERAMIC LEADLESS CHIP CARRIER (LCC)	-40°C TO +85°C	13	NO	I	NO	GOLD
HI-3183CLT	28 PIN CERAMIC LEADLESS CHIP CARRIER (LCC)	-55°C TO +125°C	13	NO	T	NO	GOLD
HI-3183CLM	28 PIN CERAMIC LEADLESS CHIP CARRIER (LCC)	-55°C TO +125°C	13	NO	M	YES	SOLDER
HI-3183CRI	32 PIN J-LEAD CERQUAD	-40°C TO +85°C	13	NO	I	NO	SOLDER
HI-3183CRT	32 PIN J-LEAD CERQUAD	-55°C TO +125°C	13	NO	T	NO	SOLDER
HI-3183PJI	28 PIN PLASTIC J - LEAD PLCC	-40°C TO +85°C	13	NO	I	NO	SOLDER
HI-3183PJT	28 PIN PLASTIC J - LEAD PLCC	-55°C TO +125°C	13	NO	T	NO	SOLDER
HI-3183PSI	16 PIN PLASTIC SMALL OUTLINE - WB (ESOIC)	-40°C TO +85°C	13	NO	I	NO	SOLDER
HI-3183PST	16 PIN PLASTIC SMALL OUTLINE - WB (ESOIC)	-55°C TO +125°C	13	NO	T	NO	SOLDER
HI-3184PSI	14 PIN PLASTIC SMALL OUTLINE - NB (ESOIC)	-40°C TO +85°C	37.5	YES	I	NO	SOLDER
HI-3184PST	14 PIN PLASTIC SMALL OUTLINE - NB (ESOIC)	-55°C TO +125°C	37.5	YES	T	NO	SOLDER
HI-3185PSI	14 PIN PLASTIC SMALL OUTLINE - NB (ESOIC)	-40°C TO +85°C	37.5	NO	I	NO	SOLDER
HI-3185PST	14 PIN PLASTIC SMALL OUTLINE - NB (ESOIC)	-55°C TO +125°C	37.5	NO	T	NO	SOLDER
HI-3186PSI	14 PIN PLASTIC SMALL OUTLINE - NB (ESOIC)	-40°C TO +85°C	0	NO	I	NO	SOLDER
HI-3186PST	14 PIN PLASTIC SMALL OUTLINE - NB (ESOIC)	-55°C TO +125°C	0	NO	T	NO	SOLDER
HI-3187PSI	14 PIN PLASTIC SMALL OUTLINE - NB (ESOIC)	-40°C TO +85°C	0	YES	I	NO	SOLDER
HI-3187PST	14 PIN PLASTIC SMALL OUTLINE - NB (ESOIC)	-55°C TO +125°C	0	YES	T	NO	SOLDER
HI-3188PSI	16 PIN PLASTIC SMALL OUTLINE - NB (ESOIC)	-40°C TO +85°C	0	NO	I	NO	SOLDER
HI-3188PST	16 PIN PLASTIC SMALL OUTLINE - NB (ESOIC)	-55°C TO +125°C	0	NO	T	NO	SOLDER

Legend: ESOIC - Thermally Enhanced Small Outline Package (SOIC w/built-in heat sink)
 NB - Narrow Body
 WB - Wide Body

14-PIN PLASTIC SMALL OUTLINE (ESQIC) - NB
(Narrow Body, Thermally Enhanced)

Package Type: 14HNE

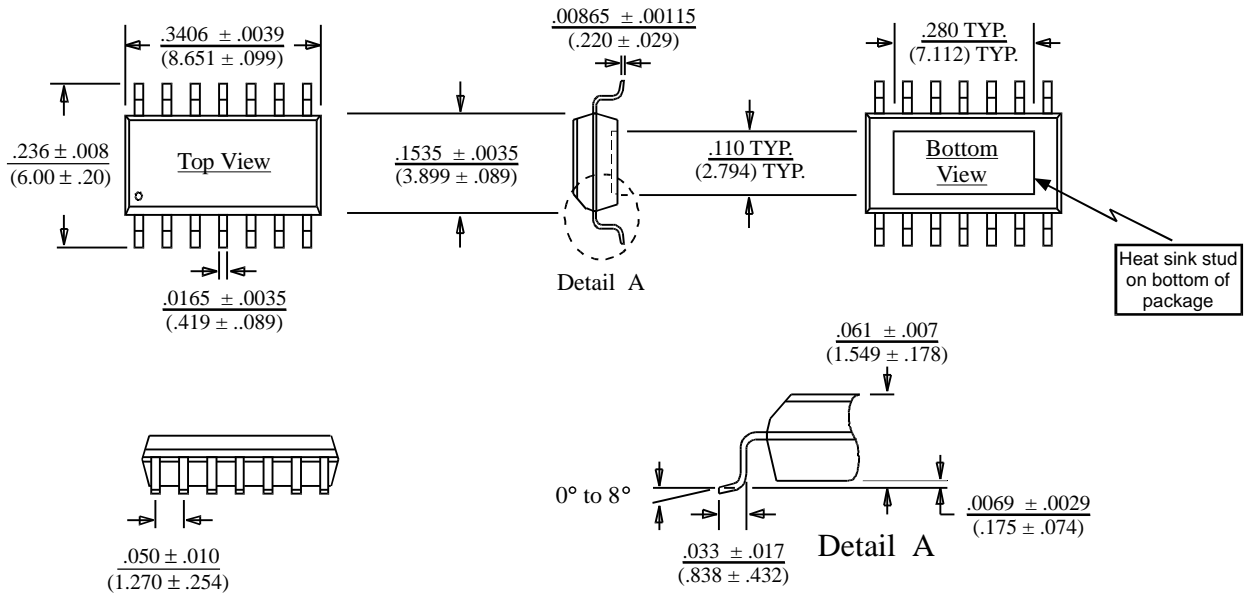

16-PIN PLASTIC SMALL OUTLINE (ESQIC) - NB
(Narrow Body, Thermally Enhanced)

Package Type: 16HNE

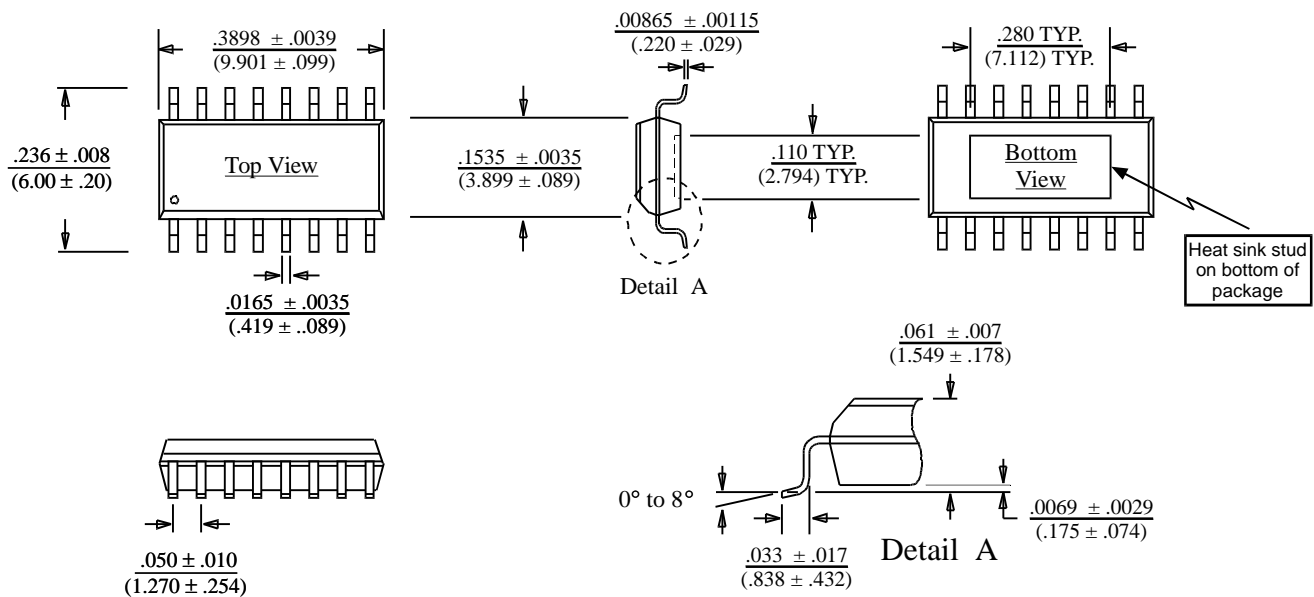

16-PIN PLASTIC SMALL OUTLINE (ESOC) - WB
(Wide Body, Thermally Enhanced)

Package Type: 16HWE

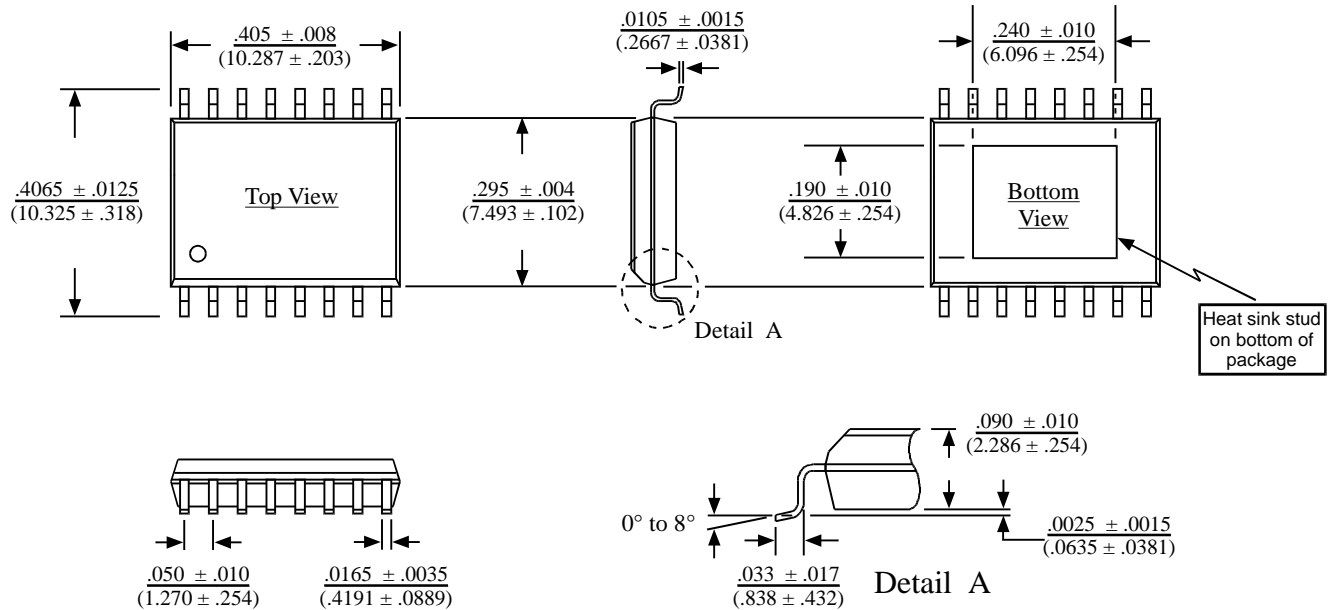

16-PIN CERAMIC SIDE-BRAZED DIP

Package Type: 16C

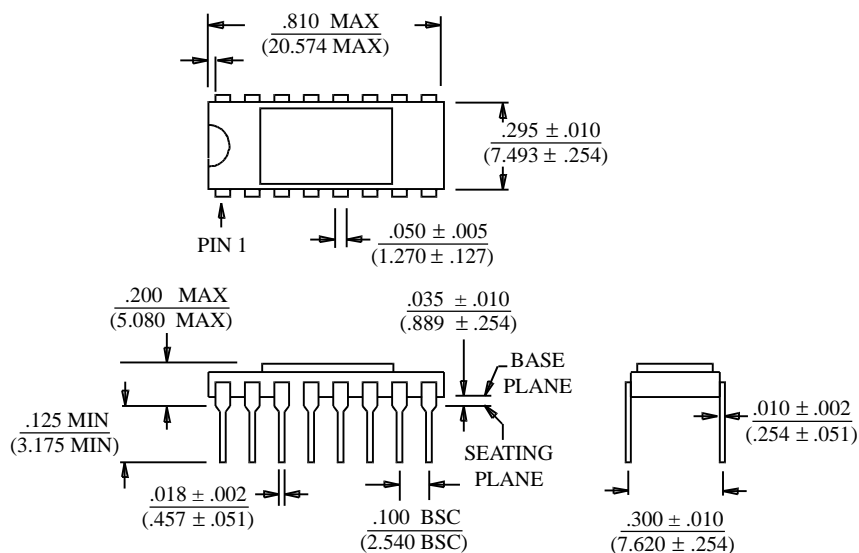

28-PIN PLASTIC PLCC

Package Type: 28J

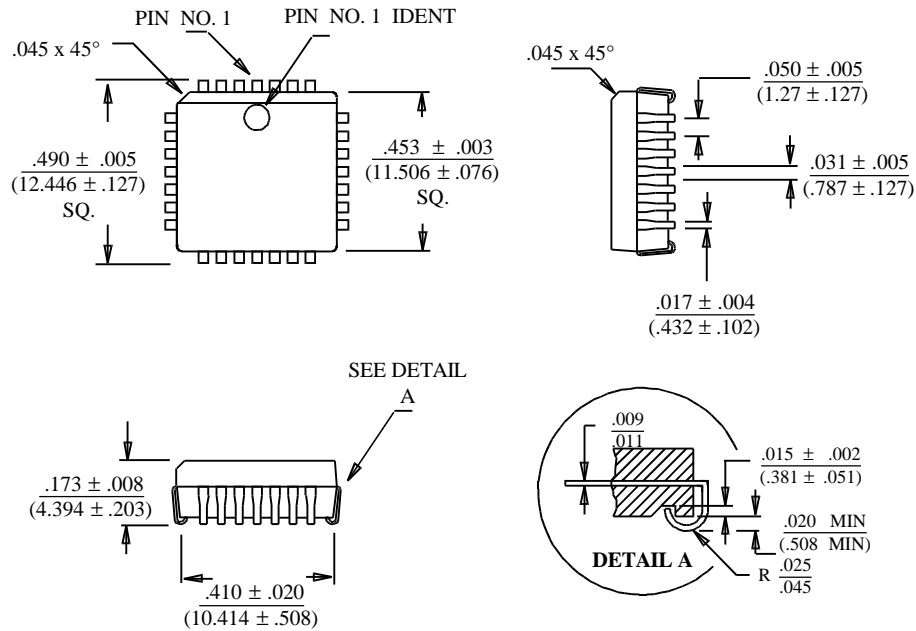

28-PIN CERAMIC LEADLESS CHIP CARRIER

Package Type: 28S

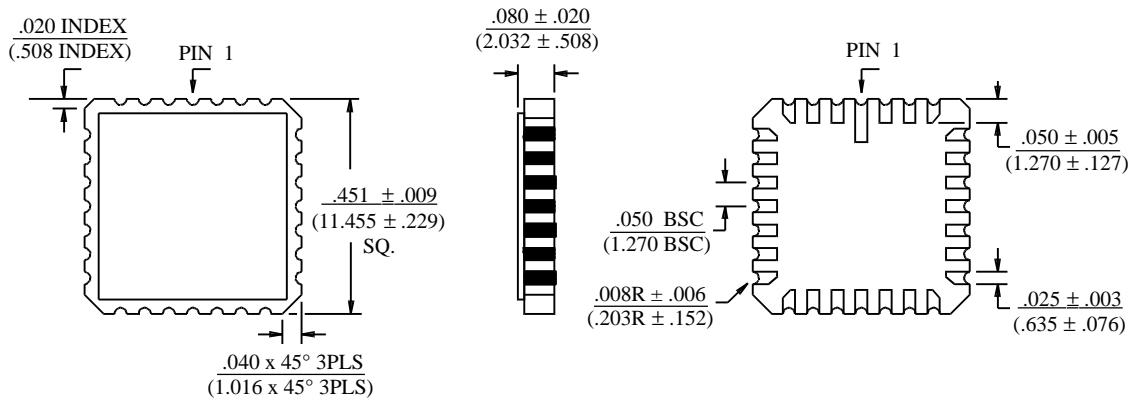

32-PIN J-LEAD CERQUAD

