

July 1998

3¹/₂ Digit, LCD/LED Display, A/D Converter

Features

- Guaranteed Zero Reading for 0V Input on All Scales
- True Polarity at Zero for Precise Null Detection
- 1pA Typical Input Current
- True Differential Input and Reference, Direct Display Drive
- Low Noise - Less Than 15µV_{p-p}
- On Chip Clock and Reference
- Low Power Dissipation - Typically Less Than 10mW
- No Additional Active Circuits Required
- Enhanced Display Stability
- Enhanced VCOM Reference Stability

Description

The Intersil HI7106 is a high performance, low power, 3¹/₂ digit A/D converter. Included are seven segment decoders, display drivers, a reference, and a clock. The HI7106 is designed to interface with a liquid crystal display (LCD) and includes a multiplexed backplane drive.

The HI7106 brings together a combination of high accuracy, versatility, and true economy. It features auto-zero to less than 10µV, zero drift of less than 1µV/°C, input bias current of 10pA (Max), and rollover error of less than one count. True differential inputs and reference are useful in all systems, but give the designer an uncommon advantage when measuring load cells, strain gauges and other bridge type transducers. Finally, the true economy of single power supply operation enables a high performance panel meter to be built with the addition of only 10 passive components and a display.

Ordering Information

PART NO.	TEMP. RANGE (°C)	PACKAGE	PKG. NO.
HI7106CPL	0 to 70	40 Ld PDIP	E40.6
HI7106CM44	0 to 70	44 Ld MQFP	Q44.10x10
HI7106C/D	0 to 70	DIE	

Pinouts

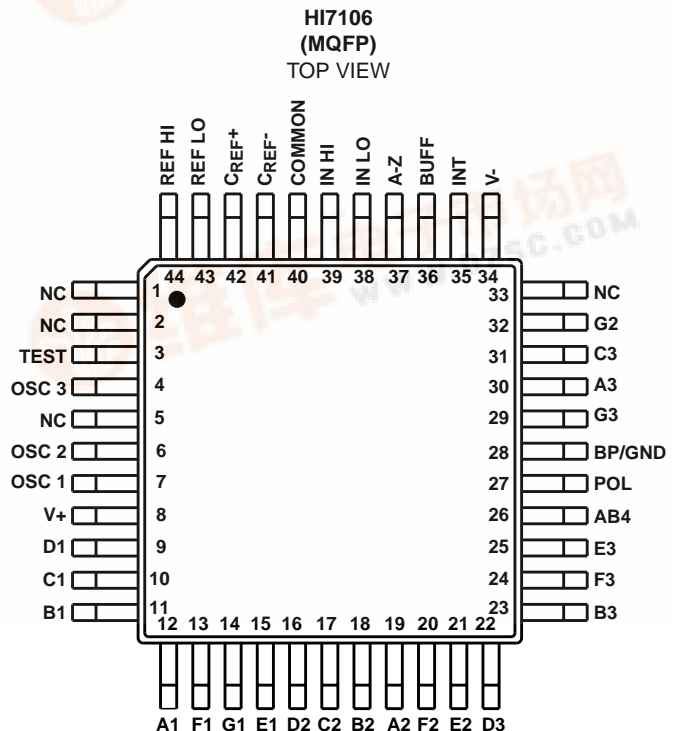
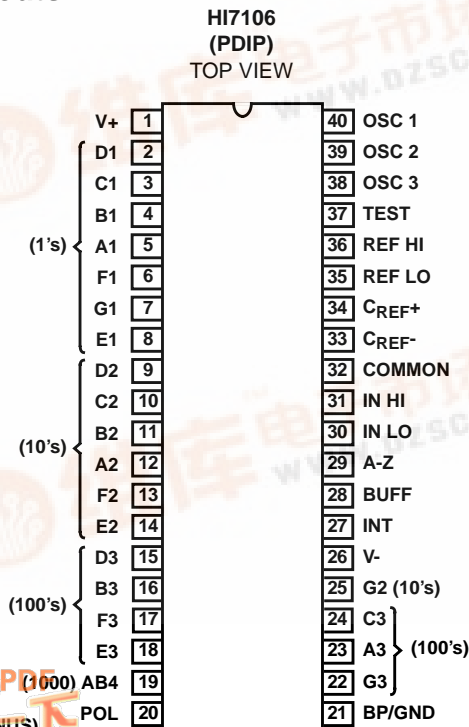

HI7106

Absolute Maximum Ratings

Supply Voltage	
HI7106, V+ to V-	15V
Analog Input Voltage (Either Input) (Note 1)	V+ to V-
Reference Input Voltage (Either Input)	V+ to V-
Clock Input	
HI7106	TEST to V+

Thermal Information

Thermal Resistance (Typical, Note 2)	θ_{JA} (°C/W)
PDIP Package	50
MQFP Package	80
Maximum Junction Temperature	150°C
Maximum Storage Temperature Range	-65°C to 150°C
Maximum Lead Temperature (Soldering 10s)	300°C
(MQFP - Lead Tips Only)	

Operating Conditions

Temperature Range 0°C to 70°C

CAUTION: Stresses above those listed in "Absolute Maximum Ratings" may cause permanent damage to the device. This is a stress only rating and operation of the device at these or any other conditions above those indicated in the operational sections of this specification is not implied.

NOTES:

1. Input voltages may exceed the supply voltages provided the input current is limited to $\pm 100\mu\text{A}$.
2. θ_{JA} is measured with the component mounted on an evaluation PC board in free air.

Electrical Specifications (Note 3)

PARAMETER	TEST CONDITIONS	MIN	TYP	MAX	UNIT
SYSTEM PERFORMANCE					
Zero Input Reading	$V_{IN} = 0.0\text{V}$, Full Scale = 200mV	-000.0	± 000.0	+000.0	Digital Reading
Stability (Last Digit)	Fixed Input Voltage (Note 6)	-000.1	± 000.0	+000.1	Digital Reading
Ratiometric Reading	$V_{IN} = V_{REF}$, $V_{REF} = 100\text{mV}$	999	999/1000	1000	Digital Reading
Rollover Error	$-V_{IN} = +V_{IN} \cong 200\text{mV}$ Difference in Reading for Equal Positive and Negative Inputs Near Full Scale	-	± 0.2	± 1	Counts
Linearity	Full Scale = 200mV or Full Scale = 2V Maximum Deviation from Best Straight Line Fit (Note 6)	-	± 0.2	± 1	Counts
Common Mode Rejection Ratio	$V_{CM} = 1\text{V}$, $V_{IN} = 0\text{V}$, Full Scale = 200mV (Note 6)	-	50	-	$\mu\text{V}/\text{V}$
Noise	$V_{IN} = 0\text{V}$, Full Scale = 200mV (Peak-To-Peak Value Not Exceeded 95% of Time)	-	15	-	μV
Leakage Current Input	$V_{IN} = 0$ (Note 6)	-	1	10	pA
Zero Reading Drift	$V_{IN} = 0$, 0°C To 70°C (Note 6)	-	0.2	1	$\mu\text{V}/^\circ\text{C}$
Scale Factor Temperature Coefficient	$V_{IN} = 199\text{mV}$, 0°C To 70°C, (Ext. Ref. 0ppm/°C) (Note 6)	-	1	5	ppm/°C
End Power Supply Character V+ Supply Current	$V_{IN} = 0$	-	0.6	1.8	mA
COMMON Pin Analog Common Voltage	25k Ω Between Common and Positive Supply (With Respect to + Supply)	2.4	2.8	3.2	V
Temperature Coefficient of Analog Common	25k Ω Between Common and Positive Supply (With Respect to + Supply)	-	80	-	ppm/°C
DISPLAY DRIVER					
Peak-To-Peak Segment Drive Voltage	V+ = to V- = 9V (Note 5)	4	5	6	V
Peak-To-Peak Backplane Drive Voltage					

NOTES:

3. Dissipation rating assumes device is mounted with all leads soldered to printed circuit board.
4. Unless otherwise noted, specifications apply to both the HI7106 and ICL7107 at $T_A = 25^\circ\text{C}$, $f_{\text{CLOCK}} = 48\text{kHz}$. HI7106 is tested in the circuit of Figure 1.
5. Back plane drive is in phase with segment drive for 'off' segment, 180 degrees out of phase for 'on' segment. Frequency is 20 times conversion rate. Average DC component is less than 50mV.
6. Not tested, guaranteed by design.

HI7106

Typical Application and Test Circuit

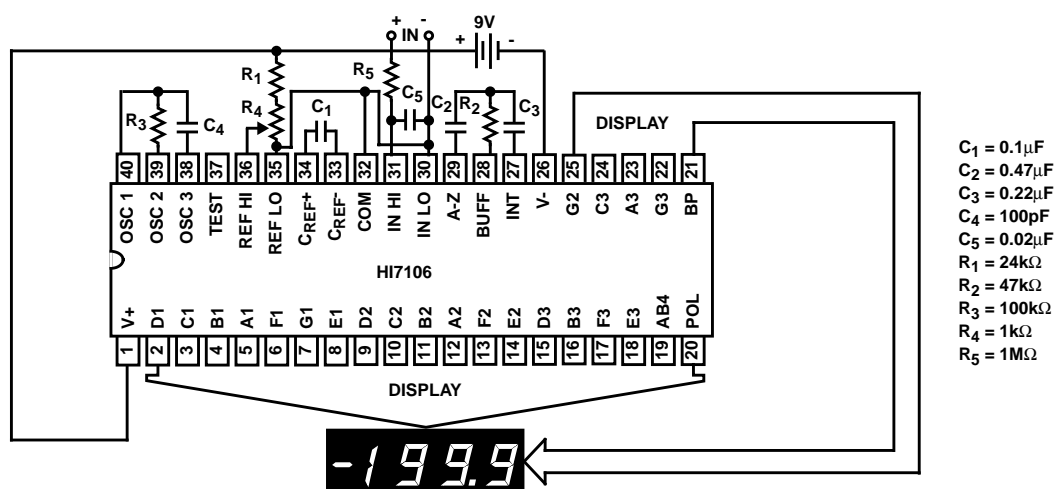

FIGURE 1. HI7106 TEST CIRCUIT AND TYPICAL APPLICATION WITH LCD DISPLAY COMPONENTS SELECTED FOR 200mV FULL SCALE

Design Information Summary Sheet

• OSCILLATOR FREQUENCY

$$f_{\text{OSC}} = 0.45/RC$$

$$C_{\text{OSC}} > 50\text{pF}; R_{\text{OSC}} > 50\text{k}\Omega$$

$$f_{\text{OSC}} (\text{Typ}) = 48\text{kHz}$$

• OSCILLATOR PERIOD

$$t_{\text{OSC}} = RC/0.45$$

• INTEGRATION CLOCK FREQUENCY

$$f_{\text{CLOCK}} = f_{\text{OSC}}/4$$

• INTEGRATION PERIOD

$$t_{\text{INT}} = 1000 \times (4/f_{\text{OSC}})$$

• 60/50Hz REJECTION CRITERION

$$t_{\text{INT}}/t_{60\text{Hz}} \text{ or } t_{\text{INT}}/t_{50\text{Hz}} = \text{Integer}$$

• OPTIMUM INTEGRATION CURRENT

$$I_{\text{INT}} = 4\mu\text{A}$$

• FULL SCALE ANALOG INPUT VOLTAGE

$$V_{\text{INFS}} (\text{Typ}) = 200\text{mV or } 2\text{V}$$

• INTEGRATE RESISTOR

$$R_{\text{INT}} = \frac{V_{\text{INFS}}}{I_{\text{INT}}}$$

• INTEGRATE CAPACITOR

$$C_{\text{INT}} = \frac{(t_{\text{INT}})(I_{\text{INT}})}{V_{\text{INT}}}$$

• INTEGRATOR OUTPUT VOLTAGE SWING

$$V_{\text{INT}} = \frac{(t_{\text{INT}})(I_{\text{INT}})}{C_{\text{INT}}}$$

• V_{INT} MAXIMUM SWING:

$$(V_- + 0.5\text{V}) < V_{\text{INT}} < (V_+ - 0.5\text{V}), V_{\text{INT}} (\text{Typ}) = 2\text{V}$$

• DISPLAY COUNT

$$\text{COUNT} = 1000 \times \frac{V_{\text{IN}}}{V_{\text{REF}}}$$

• CONVERSION CYCLE

$$t_{\text{CYC}} = t_{\text{CLOCK}} \times 4000$$

$$t_{\text{CYC}} = t_{\text{OSC}} \times 16,000$$

when $f_{\text{OSC}} = 48\text{kHz}$; $t_{\text{CYC}} = 333\text{ms}$

• COMMON MODE INPUT VOLTAGE

$$(V_- + 1\text{V}) < V_{\text{IN}} < (V_+ - 0.5\text{V})$$

• AUTO-ZERO CAPACITOR

$$0.01\mu\text{F} < C_{\text{AZ}} < 1\mu\text{F}$$

• REFERENCE CAPACITOR

$$0.1\mu\text{F} < C_{\text{REF}} < 1\mu\text{F}$$

• V_{COM}

Biased between V_i and V_- .

• $V_{\text{COM}} \cong V_+ - 2.8\text{V}$

Regulation lost when V_+ to $V_- < \cong 6.8\text{V}$
If V_{COM} is externally pulled down to $(V_+ \text{ to } V_-)/2$, the V_{COM} circuit will turn off.

• HI7106 POWER SUPPLY: SINGLE 9V

$V_+ - V_- = 9\text{V}$
Digital supply is generated internally
 $V_{\text{GND}} \cong V_+ - 4.5\text{V}$

• HI7106 DISPLAY: LCD

Type: Direct drive with digital logic supply amplitude.

HI7106

Typical Integrator Amplifier Output Waveform (INT Pin)

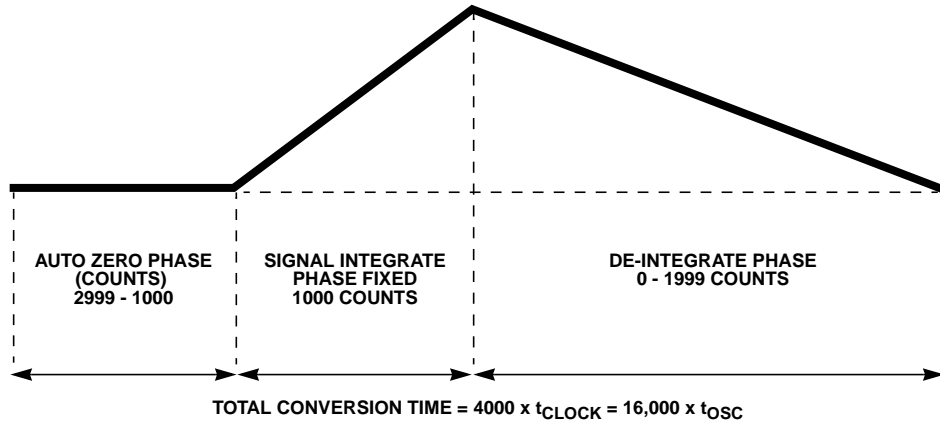

Detailed Description

Analog Section

Figure 2 shows the Analog Section for the HI7106. Each measurement cycle is divided into three phases. They are (1) auto-zero (A-Z), (2) signal integrate (INT) and (3) de-integrate (DE).

Auto-Zero Phase

During auto-zero three things happen. First, input high and low are disconnected from the pins and internally shorted to analog COMMON. Second, the reference capacitor is charged to the reference voltage. Third, a feedback loop is closed around the system to charge the auto-zero capacitor C_{AZ} to compensate for offset voltages in the buffer amplifier, integrator, and comparator. Since the comparator is included in the loop, the A-Z accuracy is limited only by the noise of

the system. In any case, the offset referred to the input is less than $10\mu\text{V}$.

Signal Integrate Phase

During signal integrate, the auto-zero loop is opened, the internal short is removed, and the internal input high and low are connected to the external pins. The converter then integrates the differential voltage between IN HI and IN LO for a fixed time. This differential voltage can be within a wide common mode range: up to 1V from either supply. If, on the other hand, the input signal has no return with respect to the converter power supply, IN LO can be tied to analog COMMON to establish the correct common mode voltage. At the end of this phase, the polarity of the integrated signal is determined.

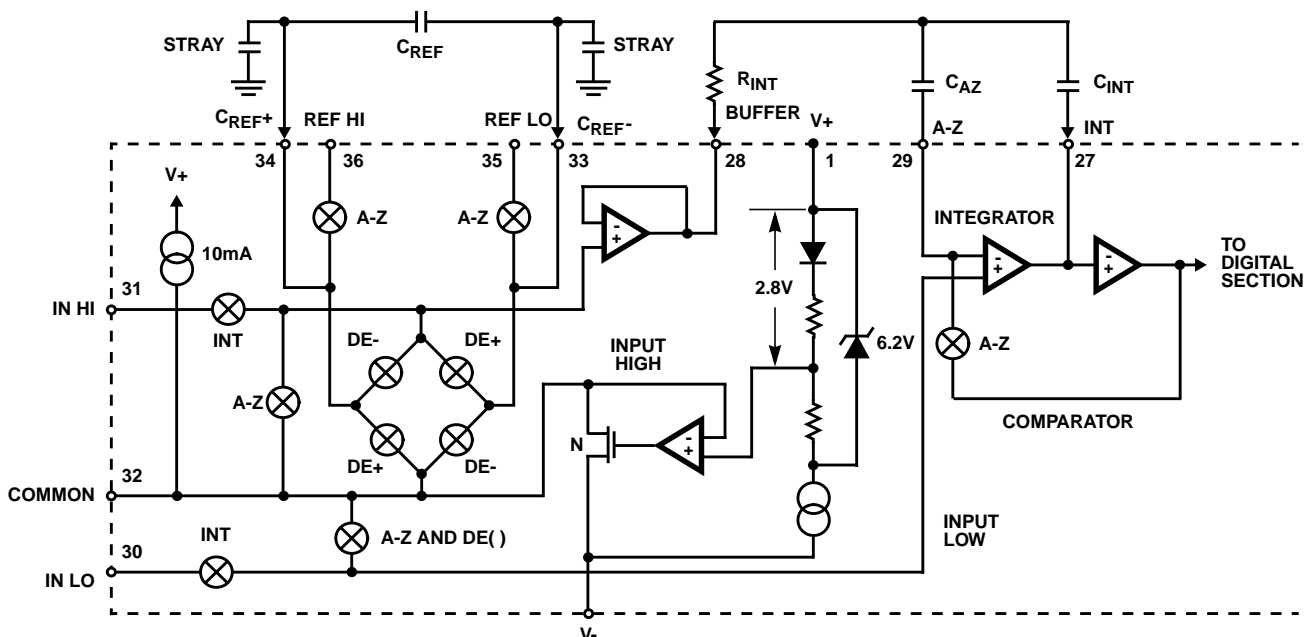

FIGURE 2. ANALOG SECTION OF HI7106

HI7106

De-Integrate Phase

The final phase is de-integrate, or reference integrate. Input low is internally connected to analog COMMON and input high is connected across the previously charged reference capacitor. Circuitry within the chip ensures that the capacitor will be connected with the correct polarity to cause the integrator output to return to zero. The time required for the output to return to zero is proportional to the input signal. Specifically the digital reading displayed is:

$$\text{DISPLAY COUNT} = 1000 \left(\frac{V_{\text{IN}}}{V_{\text{REF}}} \right).$$

Differential Input

The input can accept differential voltages anywhere within the common mode range of the input amplifier, or specifically from 0.5V below the positive supply to 1V above the negative supply. In this range, the system has a CMRR of 86dB typical. However, care must be exercised to assure the integrator output does not saturate. A worst case condition would be a large positive common mode voltage with a near full scale negative differential input voltage. The negative input signal drives the integrator positive when most of its swing has been used up by the positive common mode voltage. For these critical applications the integrator output swing can be reduced to less than the recommended 2V full scale swing with little loss of accuracy. The integrator output can swing to within 0.3V of either supply without loss of linearity.

Differential Reference

The reference voltage can be generated anywhere within the power supply voltage of the converter. The main source of common mode error is a roll-over voltage caused by the reference capacitor losing or gaining charge to stray capacity on its nodes. If there is a large common mode voltage, the reference capacitor can gain charge (increase voltage) when called up to de-integrate a positive signal but lose charge (decrease voltage) when called up to de-integrate a negative input signal. This difference in reference for positive or negative input voltage will give a roll-over error. However, by selecting the reference capacitor such that it is large enough in comparison to the stray capacitance, this error can be held to less than 0.5 count worst case. (See Component Value Selection.)

Analog COMMON

This pin is included primarily to set the common mode voltage for battery operation or for any system where the input signals are floating with respect to the power supply. The COMMON pin sets a voltage that is approximately 2.8V more negative than the positive supply. This is selected to give a minimum end-of-life battery voltage of about 6V. However, analog COMMON has some of the attributes of a reference voltage. When the total supply voltage is large enough to cause the zener to regulate (>7V), the COMMON voltage will have a low voltage coefficient (0.001%/V), low output impedance ($\approx 15\Omega$), and a temperature coefficient typically less than 80ppm/ $^{\circ}\text{C}$. An external reference can easily be added, as shown in Figure 3.

Analog COMMON is also used as the input low return during auto-zero and de-integrate. If IN LO is different from analog COMMON, a common mode voltage exists in the system and is taken care of by the excellent CMRR of the converter. However, in some applications IN LO will be set at a fixed known voltage (power supply common for instance). In this application, analog COMMON should be tied to the same point, thus removing the common mode voltage from the converter. The same holds true for the reference voltage. If reference can be conveniently tied to analog COMMON, it should be since this removes the common mode voltage from the reference system.

Within the IC, analog COMMON is tied to an N-Channel FET that can sink approximately 30mA of current to hold the voltage 2.8V below the positive supply (when a load is trying to pull the common line positive). However, there is only 10 μA of source current, so COMMON may easily be tied to a more negative voltage thus overriding the internal reference.

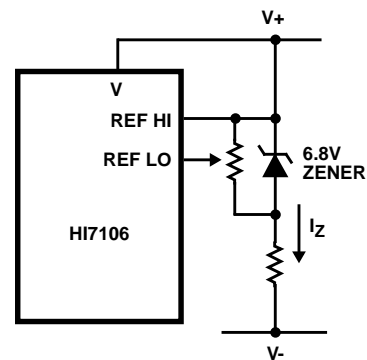

FIGURE 3A.

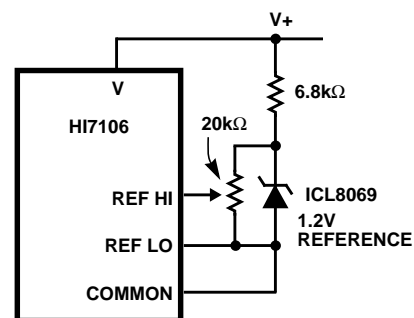

FIGURE 3B.

FIGURE 3. USING AN EXTERNAL REFERENCE

TEST

The TEST pin serves two functions. On the HI7106 it is coupled to the internally generated digital supply through a 500 Ω resistor. Thus it can be used as the negative supply for externally generated segment drivers such as decimal points or any other presentation the user may want to include on the LCD display. Figures 4 and 5 show such an application. No more than a 1mA load should be applied.

HI7106

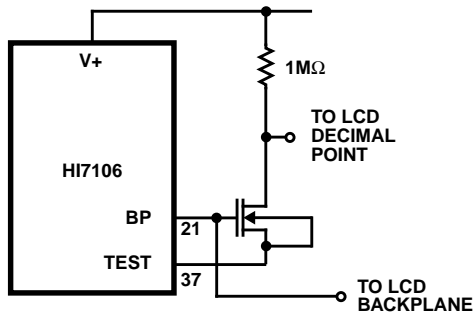

FIGURE 4. SIMPLE INVERTER FOR FIXED DECIMAL POINT

The second function is a "lamp test". When TEST is pulled high (to V+) all segments will be turned on and the display should read "1888". The TEST pin will sink about 15mA under these conditions.

CAUTION: In the lamp test mode, the segments have a constant DC voltage (no square-wave). This may burn the LCD display if maintained for extended periods.

Digital Section

Figure 6 shows the digital section for the HI7106. In the HI7106, an internal digital ground is generated from a 6V Zener diode and a large P-Channel source follower.

This supply is made stiff to absorb the relative large capacitive currents when the back plane (BP) voltage is switched. The BP frequency is the clock frequency divided by 800. For three readings/sec., this is a 60Hz square wave with a nominal amplitude of 5V. The segments are driven at the same frequency and amplitude and are in phase with BP when OFF, but out of phase when ON. In all cases negligible DC voltage exists across the segments.

The polarity indication is "on" for negative analog inputs. If IN LO and IN HI are reversed, this indication can be reversed also, if desired.

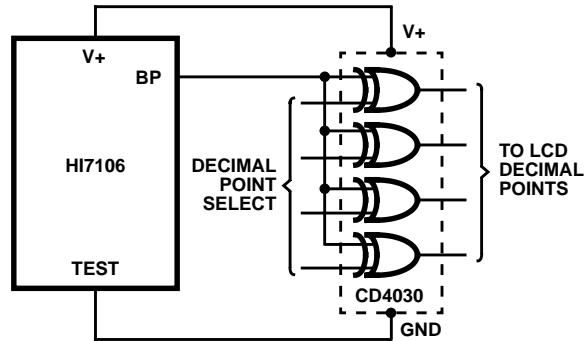

FIGURE 5. EXCLUSIVE 'OR' GATE FOR DECIMAL POINT DRIVE

0123456789

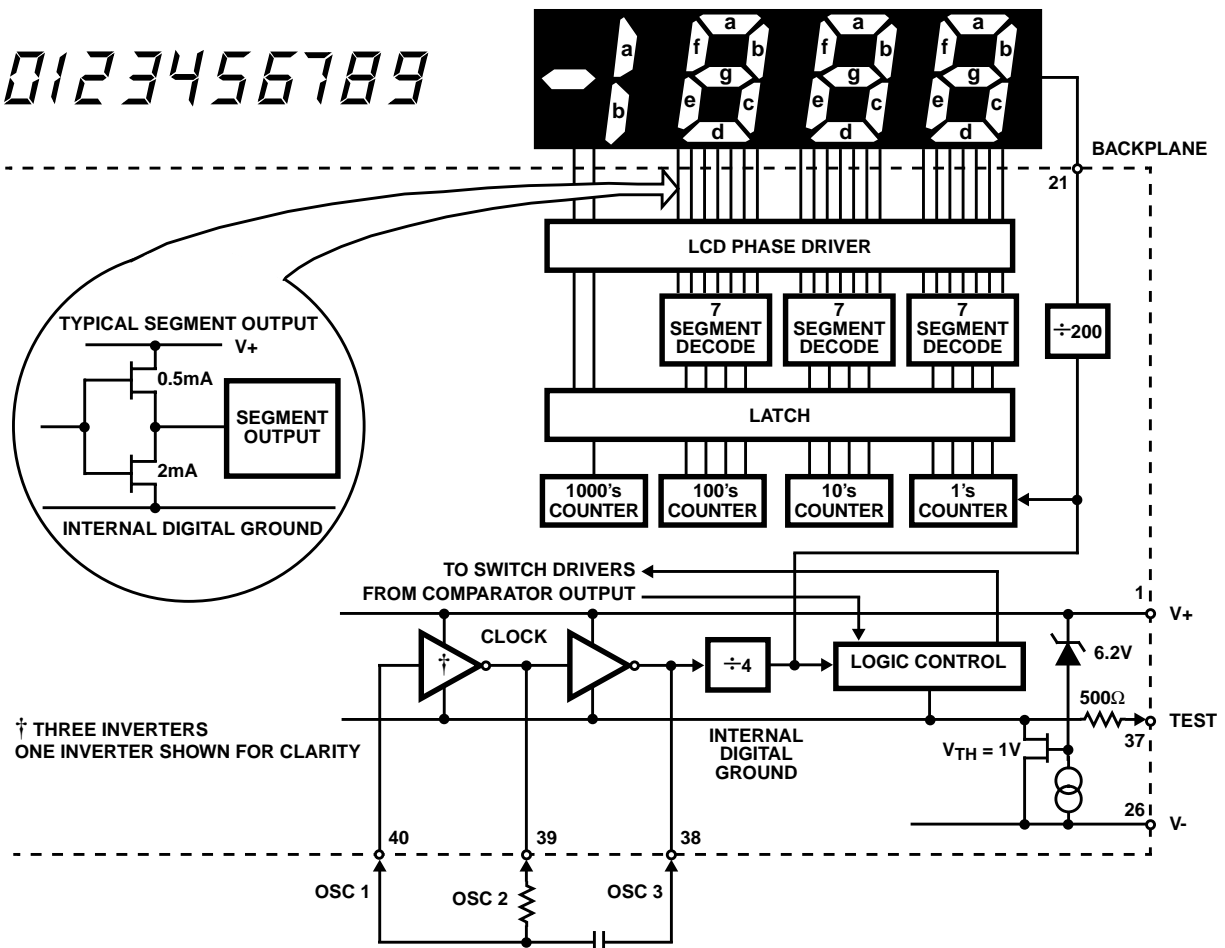

FIGURE 6. HI7106 DIGITAL SECTION

HI7106

System Timing

Figure 7 shows the clocking arrangement used in the HI7106. Two basic clocking arrangements can be used:

- Figure 7A. An external oscillator connected to pin 40.
- Figure 7B. An R-C oscillator using all three pins.

The oscillator frequency is divided by four before it clocks the decade counters. It is then further divided to form the three convert-cycle phases. These are signal integrate (1000 counts), reference de-integrate (0 to 2000 counts) and auto-zero (1000 to 3000 counts). For signals less than full scale, auto-zero gets the unused portion of reference de-integrate. This makes a complete measure cycle of 4,000 counts (16,000 clock pulses) independent of input voltage. For three readings/second, an oscillator frequency of 48kHz would be used.

To achieve maximum rejection of 60Hz pickup, the signal integrate cycle should be a multiple of 60Hz. Oscillator frequencies of 240kHz, 120kHz, 80kHz, 60kHz, 48kHz, 40kHz, $33\frac{1}{3}$ kHz, etc. should be selected. For 50Hz rejection, Oscillator frequencies of 200kHz, 100kHz, $66\frac{2}{3}$ kHz, 50kHz, 40kHz, etc. would be suitable. Note that 40kHz (2.5 readings/second) will reject both 50Hz and 60Hz (also 400Hz and 440Hz).

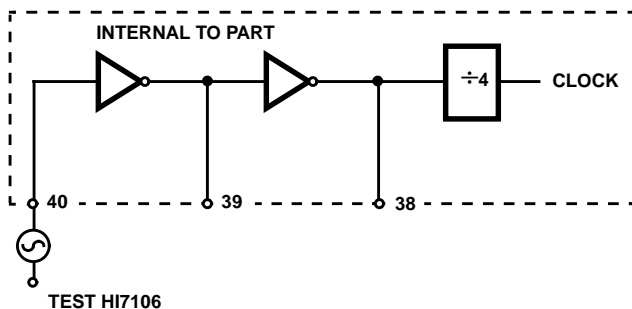

FIGURE 7A.

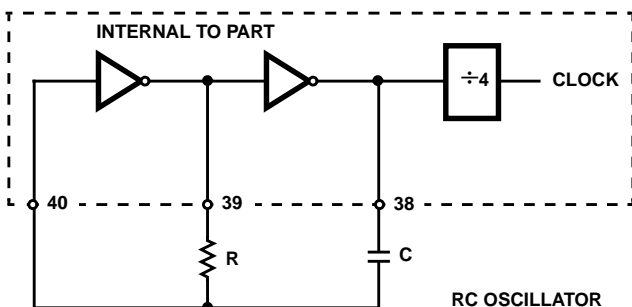

FIGURE 7B.

FIGURE 7. CLOCK CIRCUITS

Component Value Selection

Integrating Resistor

Both the buffer amplifier and the integrator have a class A output stage with $100\mu\text{A}$ of quiescent current. They can

supply $4\mu\text{A}$ of drive current with negligible nonlinearity. The integrating resistor should be large enough to remain in this very linear region over the input voltage range, but small enough that undue leakage requirements are not placed on the PC board. For 2V full scale, $470\text{k}\Omega$ is near optimum and similarly a $47\text{k}\Omega$ for a 200mV scale.

Integrating Capacitor

The integrating capacitor should be selected to give the maximum voltage swing that ensures tolerance buildup will not saturate the integrator swing (approximately 0.3V from either supply). In the HI7106, when the analog COMMON is used as a reference, a nominal +2V full-scale integrator swing is fine. For three readings/second (48kHz clock) nominal values for C_{INT} are $0.22\mu\text{F}$ and $0.10\mu\text{F}$, respectively. Of course, if different oscillator frequencies are used, these values should be changed in inverse proportion to maintain the same output swing.

An additional requirement of the integrating capacitor is that it must have a low dielectric absorption to prevent roll-over errors. While other types of capacitors are adequate for this application, polypropylene capacitors give undetectable errors at reasonable cost.

Auto-Zero Capacitor

The size of the auto-zero capacitor has some influence on the noise of the system. For 200mV full scale where noise is very important, a $0.47\mu\text{F}$ capacitor is recommended. On the 2V scale, a $0.047\mu\text{F}$ capacitor increases the speed of recovery from overload and is adequate for noise on this scale.

Reference Capacitor

A $0.1\mu\text{F}$ capacitor gives good results in most applications. However, where a large common mode voltage exists (i.e., the REF LO pin is not at analog COMMON) and a 200mV scale is used, a larger value is required to prevent roll-over error. Generally $1\mu\text{F}$ will hold the roll-over error to 0.5 count in this instance.

Oscillator Components

For all ranges of frequency a $100\text{k}\Omega$ resistor is recommended and the capacitor is selected from the equation:

$$f = \frac{0.45}{RC} \text{ For } 48\text{kHz Clock (3 Readings/sec),}$$

$$C = 100\text{pF.}$$

Reference Voltage

The analog input required to generate full scale output (2000 counts) is: $V_{\text{IN}} = 2V_{\text{REF}}$. Thus, for the 200mV and 2V scale, V_{REF} should equal 100mV and 1V, respectively. However, in many applications where the A/D is connected to a transducer, there will exist a scale factor other than unity between the input voltage and the digital reading. For instance, in a weighing system, the designer might like to have a full scale reading when the voltage from the transducer is 0.662V. Instead of dividing the input down to 200mV, the designer should use the input voltage directly

HI7106

and select $V_{REF} = 0.341V$. Suitable values for integrating resistor and capacitor would be $20k\Omega$ and $0.22\mu F$. This makes the system slightly quieter and also avoids a divider network on the input. Another advantage of this system occurs when a digital reading of zero is desired for $V_{IN} \neq 0$. Temperature and weighing systems with a variable fare are examples. This offset reading can be conveniently generated by connecting the voltage transducer between IN HI and COMMON and the variable (or fixed) offset voltage between COMMON and IN LO.

Typical Applications

The HI7106 may be used in a wide variety of configurations. The circuits which follow show some of the possibilities, and serve to illustrate the exceptional versatility of this A/D converter.

Typical Applications

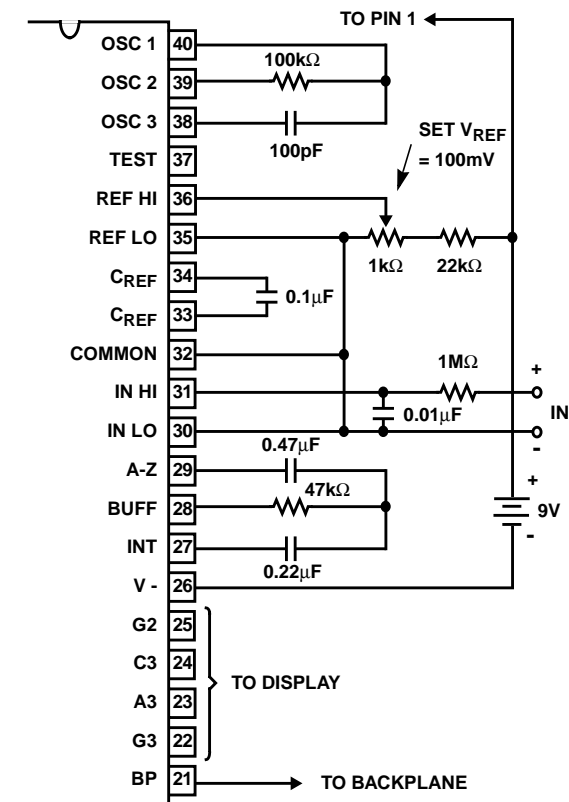

Values shown are for 200mV full scale, 3 readings/sec., floating supply voltage (9V battery).

FIGURE 8. HI7106 USING THE INTERNAL REFERENCE

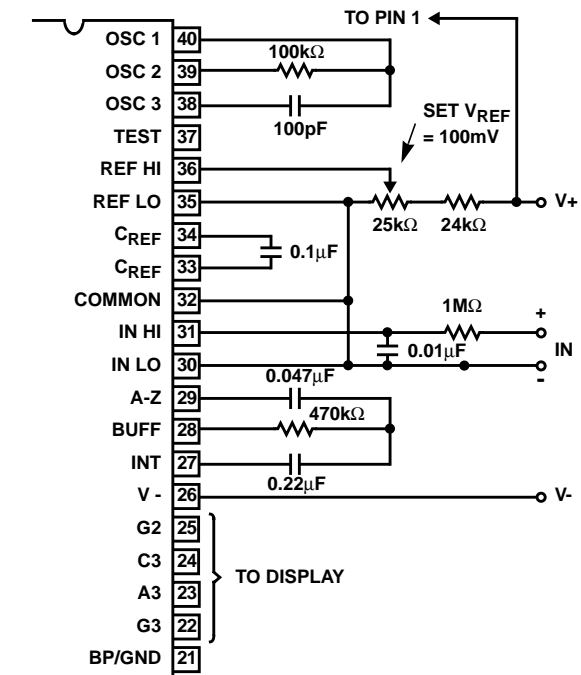
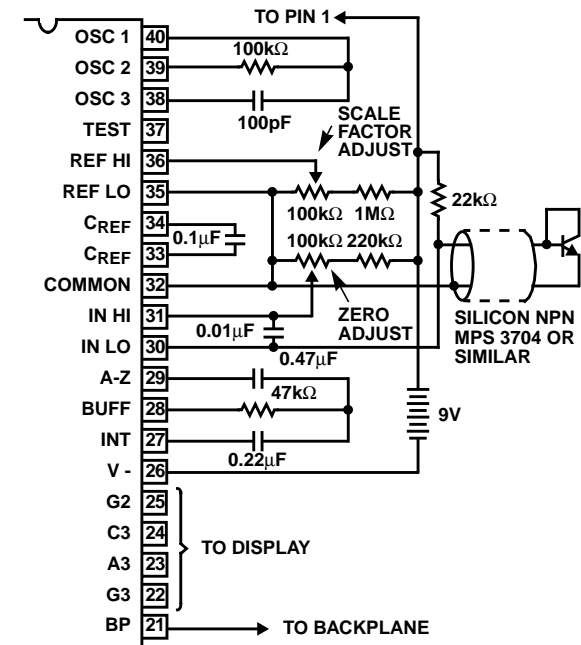

FIGURE 9. HI7106 RECOMMENDED COMPONENT VALUES FOR 2V FULL SCALE

HI7106

Typical Applications (Continued)



NOTE: A silicon diode-connected transistor has a temperature coefficient of about $-2\text{mV}/^\circ\text{C}$. Calibration is achieved by placing the sensing transistor in ice water and adjusting the zeroing potentiometer for a 000.0 reading. The sensor should then be placed in boiling water and the scale-factor potentiometer adjusted for a 100.0 reading.

FIGURE 10. HI7106 USED AS A DIGITAL CENTIGRADE THERMOMETER

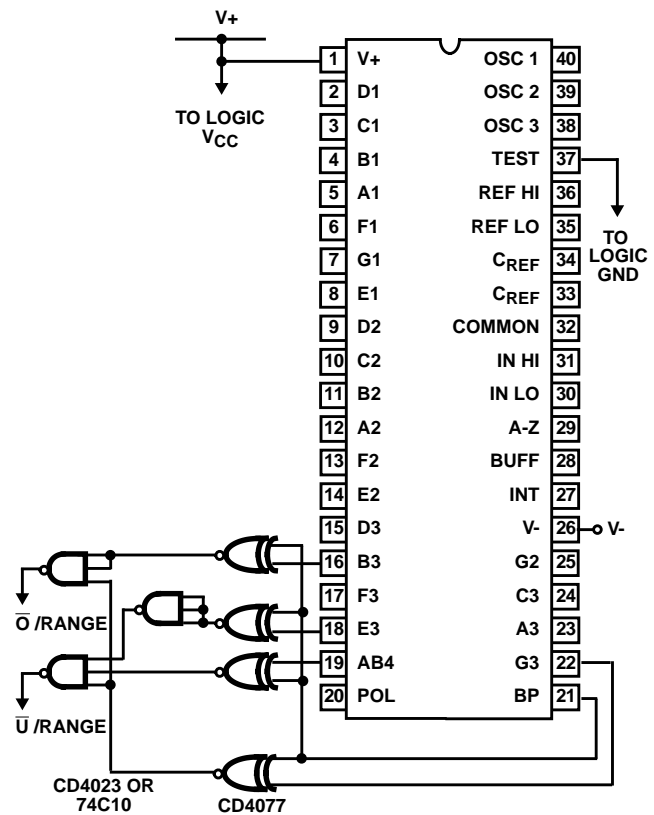
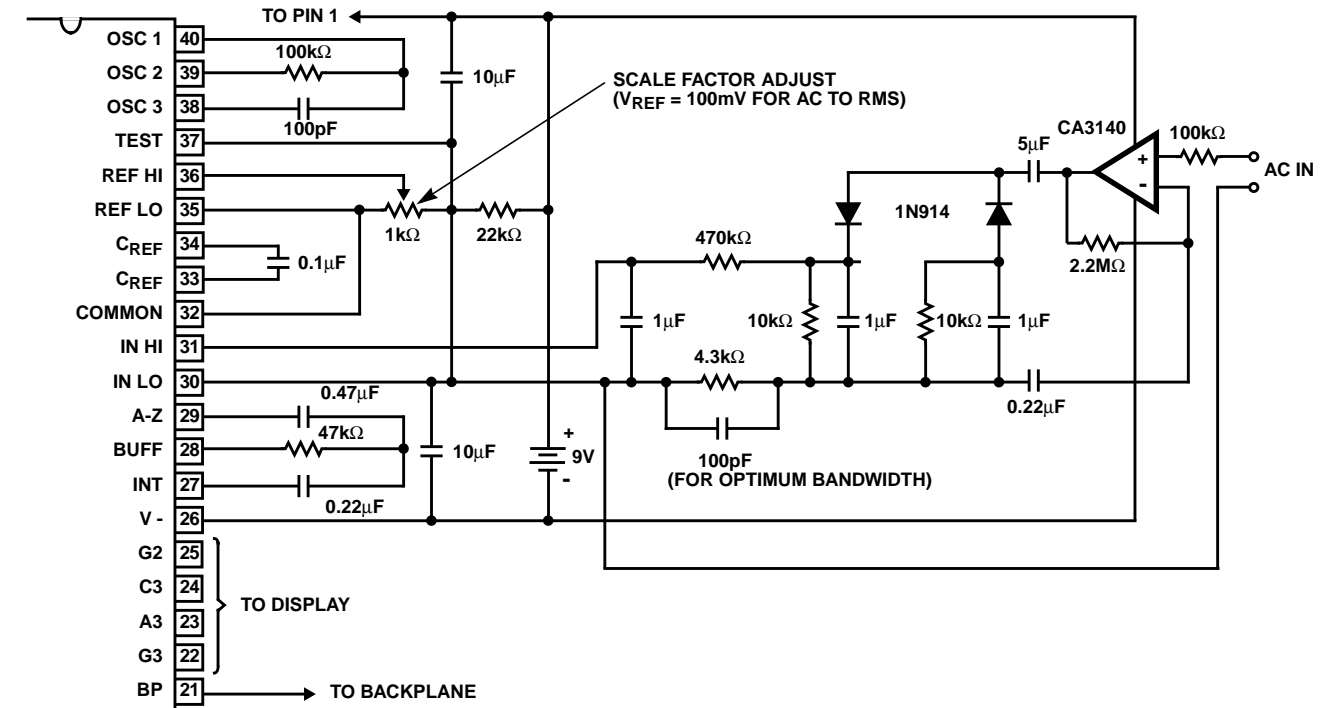

FIGURE 11. CIRCUIT FOR DEVELOPING UNDERRANGE AND OVERRANGE SIGNAL FROM HI7106 OUTPUTS



NOTE: Test is used as a common-mode reference level to ensure compatibility with most op amps.

FIGURE 12. AC TO DC CONVERTER WITH HI7106

HI7106

Dual-In-Line Plastic Packages (PDIP)

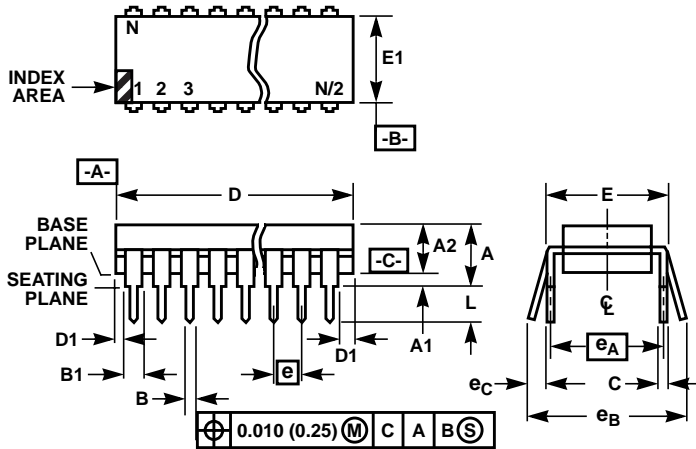

NOTES:

1. Controlling Dimensions: INCH. In case of conflict between English and Metric dimensions, the inch dimensions control.
2. Dimensioning and tolerancing per ANSI Y14.5M-1982.
3. Symbols are defined in the "MO Series Symbol List" in Section 2.2 of Publication No. 95.
4. Dimensions A, A1 and L are measured with the package seated in JEDEC seating plane gauge GS-3.
5. D, D1, and E1 dimensions do not include mold flash or protrusions. Mold flash or protrusions shall not exceed 0.010 inch (0.25mm).
6. E and e_A are measured with the leads constrained to be perpendicular to datum $-C-$.
7. e_B and e_C are measured at the lead tips with the leads unconstrained. e_C must be zero or greater.
8. B1 maximum dimensions do not include dambar protrusions. Dambar protrusions shall not exceed 0.010 inch (0.25mm).
9. N is the maximum number of terminal positions.
10. Corner leads (1, N, N/2 and N/2 + 1) for E8.3, E16.3, E18.3, E28.3, E42.6 will have a B1 dimension of 0.030 - 0.045 inch (0.76 - 1.14mm).

E40.6 (JEDEC MS-011-AC ISSUE B) 40 LEAD DUAL-IN-LINE PLASTIC PACKAGE

SYMBOL	INCHES		MILLIMETERS		NOTES
	MIN	MAX	MIN	MAX	
A	-	0.250	-	6.35	4
A1	0.015	-	0.39	-	4
A2	0.125	0.195	3.18	4.95	-
B	0.014	0.022	0.356	0.558	-
B1	0.030	0.070	0.77	1.77	8
C	0.008	0.015	0.204	0.381	-
D	1.980	2.095	50.3	53.2	5
D1	0.005	-	0.13	-	5
E	0.600	0.625	15.24	15.87	6
E1	0.485	0.580	12.32	14.73	5
e	0.100 BSC		2.54 BSC		-
e_A	0.600 BSC		15.24 BSC		6
e_B	-	0.700	-	17.78	7
L	0.115	0.200	2.93	5.08	4
N	40		40		9

Rev. 0 12/93

HI7106

Metric Plastic Quad Flatpack Packages (MQFP/PQFP)

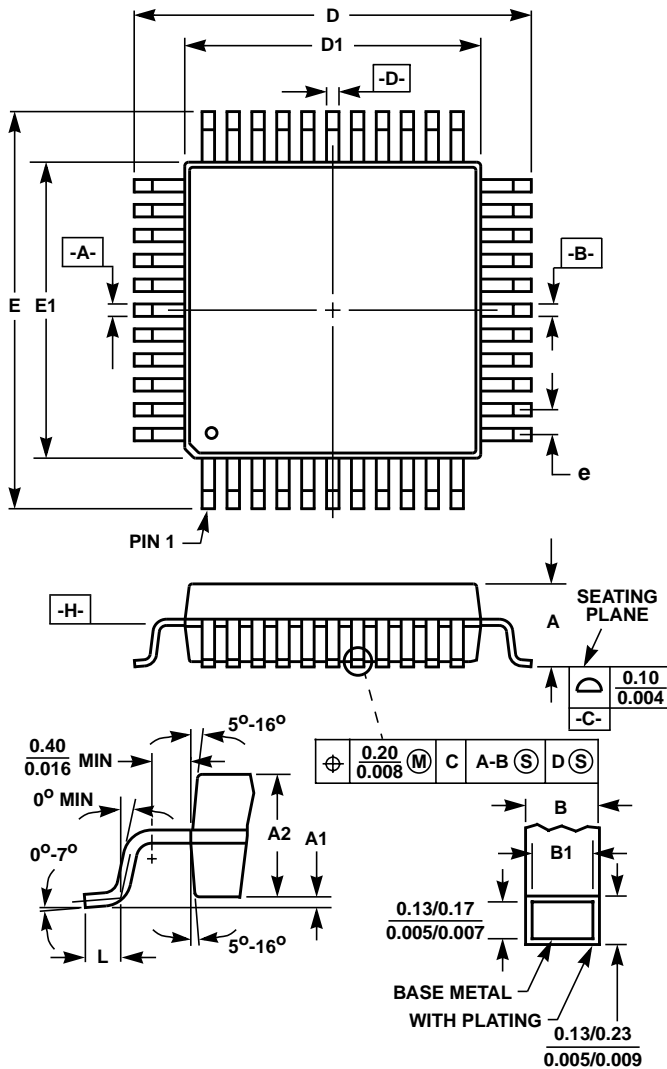

Q44.10x10 (JEDEC MO-108AA-2 ISSUE A) 44 LEAD METRIC PLASTIC QUAD FLATPACK PACKAGE

SYM-BOL	INCHES		MILLIMETERS		NOTES
	MIN	MAX	MIN	MAX	
A	-	0.093	-	2.35	-
A1	0.004	0.010	0.10	0.25	-
A2	0.077	0.083	1.95	2.10	-
B	0.012	0.018	0.30	0.45	6
B1	0.012	0.016	0.30	0.40	-
D	0.510	0.530	12.95	13.45	3
D1	0.390	0.398	9.90	10.10	4, 5
E	0.510	0.530	12.95	13.45	3
E1	0.390	0.398	9.90	10.10	4, 5
L	0.026	0.037	0.65	0.95	-
N	44		44		7
e	0.032 BSC		0.80 BSC		-

Rev. 1 1/94

NOTES:

- Controlling dimension: MILLIMETER. Converted inch dimensions are not necessarily exact.
- All dimensions and tolerances per ANSI Y14.5M-1982.
- Dimensions D and E to be determined at seating plane [-C-].
- Dimensions D1 and E1 to be determined at datum plane [-H-].
- Dimensions D1 and E1 do not include mold protrusion. Allowable protrusion is 0.25mm (0.010 inch) per side.
- Dimension B does not include dambar protrusion. Allowable dambar protrusion shall be 0.08mm (0.003 inch) total.
- "N" is the number of terminal positions.

All Intersil semiconductor products are manufactured, assembled and tested under **ISO9000** quality systems certification.

Intersil products are sold by description only. Intersil Corporation reserves the right to make changes in circuit design and/or specifications at any time without notice. Accordingly, the reader is cautioned to verify that data sheets are current before placing orders. Information furnished by Intersil is believed to be accurate and reliable. However, no responsibility is assumed by Intersil or its subsidiaries for its use; nor for any infringements of patents or other rights of third parties which may result from its use. No license is granted by implication or otherwise under any patent or patent rights of Intersil or its subsidiaries.

For information regarding Intersil Corporation and its products, see web site <http://www.intersil.com>

Sales Office Headquarters

NORTH AMERICA
Intersil Corporation
P. O. Box 883, Mail Stop 53-204
Melbourne, FL 32902
TEL: (407) 724-7000
FAX: (407) 724-7240

EUROPE
Intersil SA
Mercure Center
100, Rue de la Fusee
1130 Brussels, Belgium
TEL: (32) 2.724.2111
FAX: (32) 2.724.22.05

ASIA
Intersil (Taiwan) Ltd.
Taiwan Limited
7F-6, No. 101 Fu Hsing North Road
Taipei, Taiwan
Republic of China
TEL: (886) 2 2716 9310
FAX: (886) 2 2715 3029