



v02.1203

HMC232C8

GaAs MMIC SMT HIGH ISOLATION SPDT SWITCH, DC - 8.0 GHz

Typical Applications

The HMC232C8 is ideal for:

- Telecom Infrastructure
- Microwave Radio & VSAT
- Military Radios, Radar & ECM
- Test Instrumentation

Features

- Isolation: 55 dB @ 2.0 GHz
43 dB @ 6.0 GHz
- Insertion Loss: 1.6 dB Typical @ 6.0 GHz
- Non-Reflective Design
- Surface Mount Ceramic Package
- Direct Replacement for HMC132C8

Functional Diagram

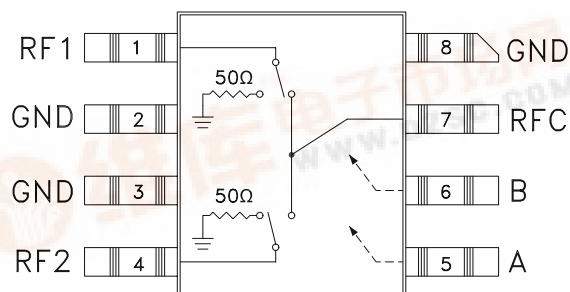

General Description

The HMC232C8 is a broadband high isolation non-reflective GaAs MESFET SPDT switch in a non-hermetic surface mount ceramic package. Covering DC to 8.0 GHz, the switch features >55 dB isolation up to 2 GHz and >42 dB isolation up to 8.0 GHz. The switch operates using complementary negative control voltage logic lines of -5/0V and requires no bias supply. This product is a form, fit & functional replacement for the HMC132C8.

Electrical Specifications, $T_A = +25^\circ C$, With 0/-5V Control, 50 Ohm System

Parameter	Frequency	Min.	Typ.	Max.	Units
Insertion Loss	DC - 2.0 GHz		1.2	1.5	dB
	DC - 6.0 GHz		1.6	2.0	dB
	DC - 8.0 GHz		2.2	2.8	dB
Isolation	DC - 2.0 GHz	50	55		dB
	DC - 6.0 GHz	38	43		dB
	DC - 8.0 GHz	37	42		dB
Return Loss	DC - 2.0 GHz		19		dB
	DC - 6.0 GHz		12		dB
	DC - 8.0 GHz		10		dB
Return Loss RF1, RF2	DC - 2.0 GHz		13		dB
	DC - 6.0 GHz		8		dB
	DC - 8.0 GHz		7		dB
Input Power for 1 dB Compression	0.5 - 8.0 GHz	22	26		dBm
Input Third Order Intercept (Two-Tone Input Power= +7 dBm Each Tone, 1 MHz Tone Separation)	0.5 - 8.0 GHz	40	46		dBm
Switching Characteristics	DC - 8.0 GHz	tRISE, tFALL (10/90% RF)	3		ns
		tON, tOFF (50% CTL to 10/90% RF)	5		ns



GaAs MMIC SMT HIGH ISOLATION SPDT SWITCH, DC - 8.0 GHz

Insertion Loss

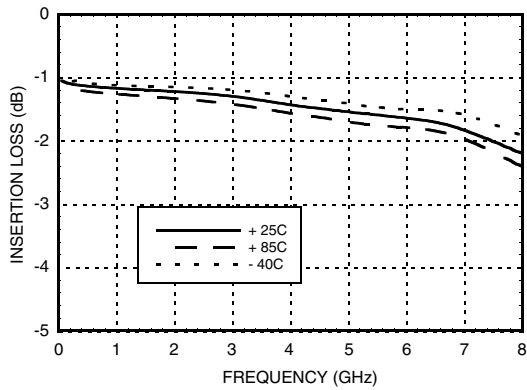

Isolation

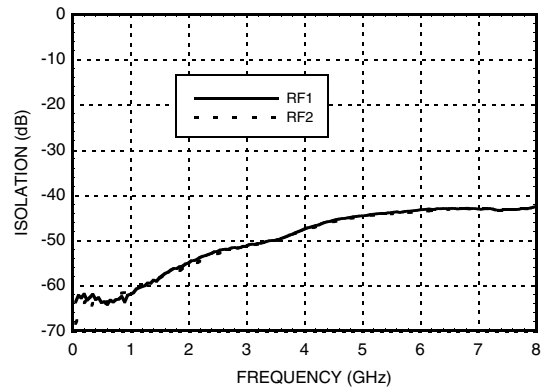

Return Loss

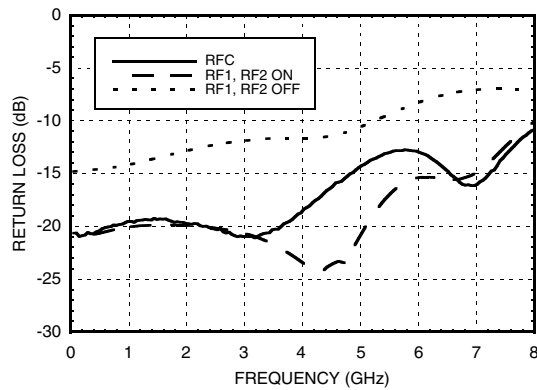

0.1 and 1 dB Input Compression Point

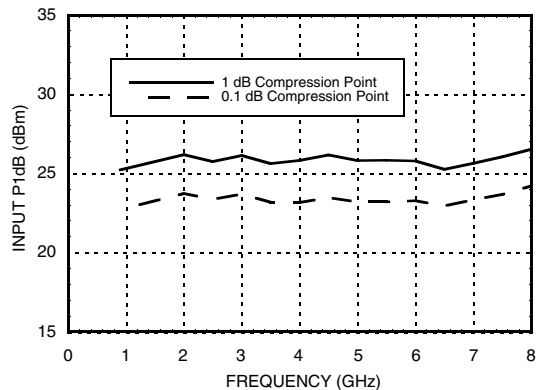

Input Third Order Intercept Point

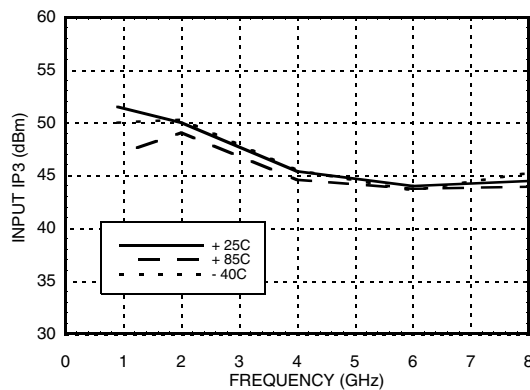

GaAs MMIC SMT HIGH ISOLATION SPDT SWITCH, DC - 8.0 GHz

Control Voltages

State	Bias Condition
Low	0 to -0.2V @ 10 uA Max.
High	-5V @ 10 uA Typ. to -7V @ 45 uA Typ.

Truth Table

Control Input		Signal Path State	
A	B	RFC to RF1	RFC to RF2
High	Low	ON	OFF
Low	High	OFF	ON

Absolute Maximum Ratings

RF Input Power (Vctl= -5V) (0.5 - 8 GHz)	+30 dBm (@ +50 °C)
Control Voltage Range (A & B)	+1.0V to -7.5 Vdc
Channel Temperature	150 °C
Thermal Resistance	94 °C/W
Storage Temperature	-65 to +150 °C
Operating Temperature	-40 to +85 °C

Caution: Do not "Hot Switch" power levels greater than +26 dBm (Vctl = 0/-5 Vdc).

Outline Drawing

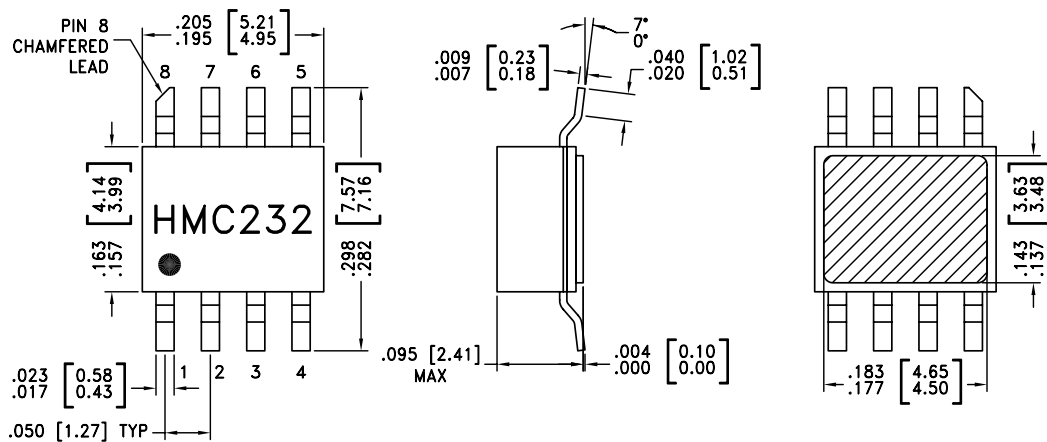

NOTES:

1. PACKAGE BODY MATERIAL: WHITE ALUMINA 92%
2. LEAD, PACKAGE BOTTOM MATERIAL: COPPER
3. PLATING: ELECTROLYTIC GOLD 100-200 MICROINCHES, OVER ELECTROLYTIC NICKEL 100-250 MICROINCHES.
4. DIMENSIONS ARE IN INCHES [MILLIMETERS].
5. PACKAGE LENGTH AND WIDTH DIMENSIONS DO NOT INCLUDE LID SEAL PROTRUSION .005 PER SIDE.
6. ALL GROUND LEADS AND GROUND PADDLE MUST BE SOLDERED TO PCB RF GROUND.

GaAs MMIC SMT HIGH ISOLATION SPDT SWITCH, DC - 8.0 GHz

Suggested Driver Circuit

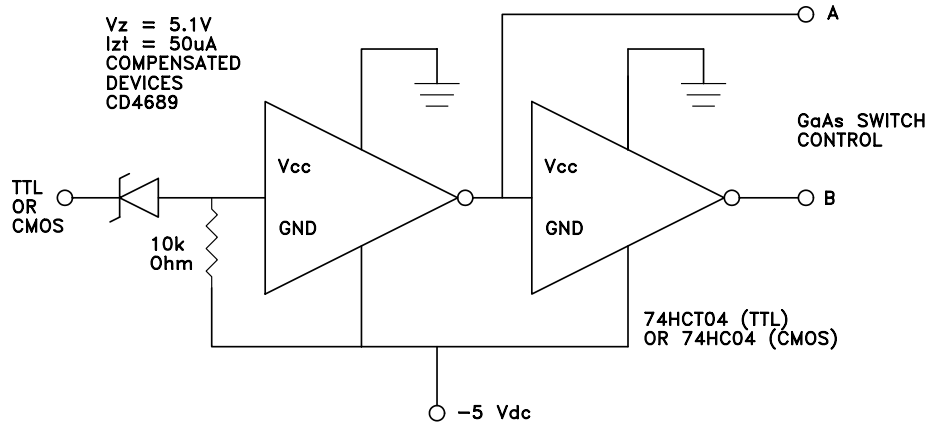

Pin Descriptions

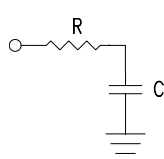
Pin Number	Function	Description	Interface Schematic
1, 4, 7	RF1, RF2, RFC	This pin is DC coupled and matched to 50 Ohm. Blocking capacitors are required if RF line potential is not equal to 0V.	
2, 3, 8	GND	Package bottom must also be connected to PCB RF ground.	
5	A	See truth table and control voltage table.	
6	B	See truth table and control voltage table.	

GaAs MMIC SMT HIGH ISOLATION SPDT SWITCH, DC - 8.0 GHz

Evaluation PCB

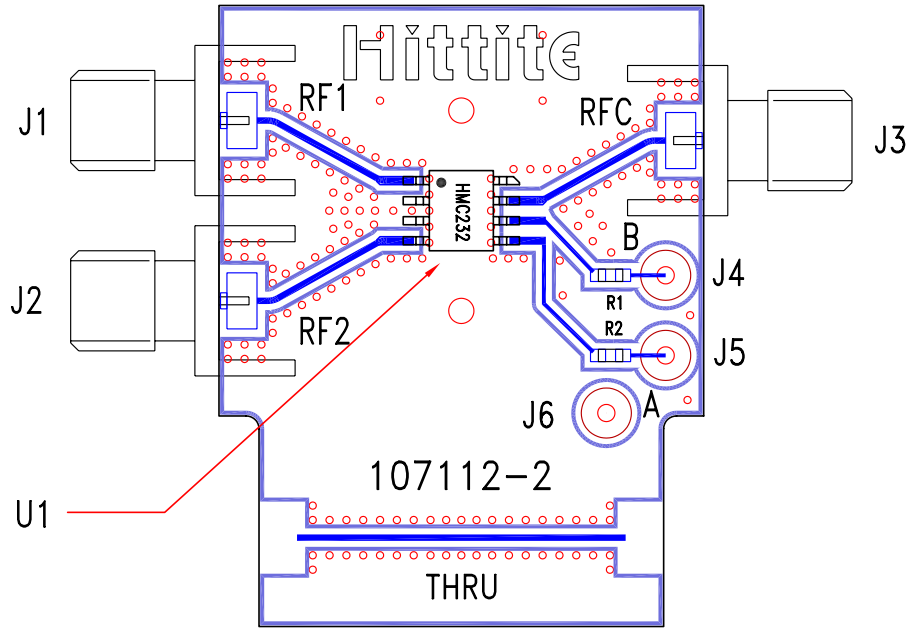

List of Material

Item	Description
J1 - J3	PC Mount SMA RF Connector
J4 - J6	DC Pin
R1, R2	100 Ohm Resistor, 0603 Pkg.
U1	HMC232C8 SPDT Switch
PCB*	107112 Evaluation PCB

* Circuit Board Material: Rogers 4350

The circuit board used in the final application should be generated with proper RF circuit design techniques. Signal lines at the RF port should have 50 ohm impedance and the package ground leads and package bottom should be connected directly to the ground plane similar to that shown above. The evaluation circuit board shown above is available from Hittite Microwave Corporation upon request.



v02.1203

HMC232C8

***GaAs MMIC SMT HIGH ISOLATION
SPDT SWITCH, DC - 8.0 GHz***

Notes: