



v04.1201

HMC283LM1

SMT MEDIUM POWER GaAs MMIC AMPLIFIER, 17 - 40 GHz

Typical Applications

The HMC283LM1 is ideal for:

- Millimeterwave Point-to-Point Radios
- LMDS
- SATCOM

Functional Diagram

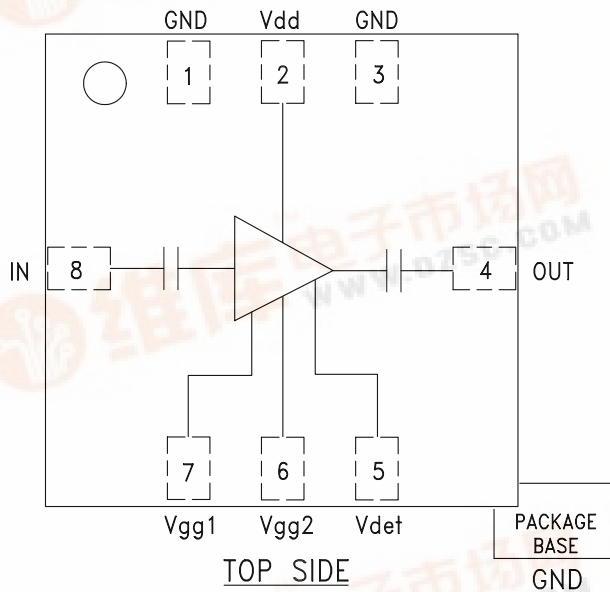

Features

- SMT mmWave Package
- Psat Output Power: +21 dBm
- High Gain: 21 dB
- No External Matching Required

General Description

The HMC283LM1 is a Medium Power Amplifier (MPA) in a SMT leadless chip carrier package covering 17 to 40 GHz. The LM1 is a true surface mount broadband millimeterwave package offering low loss & excellent I/O match preserving MMIC chip performance. Utilizing a GaAs PHEMT process, the device offers 20 dB gain and +21 dBm output power from a bias supply of +3.5V @ 300mA. As an alternative to chip-and-wire hybrid assemblies the HMC283LM1 eliminates the need for wirebonding, thereby providing a consistent connection interface for the customer. The amplifier may be used as a frequency doubler. A built-in-test pad (Vdet) allows monitoring of microwave output power. All data is with the non-hermetic, epoxy sealed LM1 packaged MPA device mounted in a 50 ohm test fixture.

Electrical Specifications, $T_A = +25^\circ C$, $V_{dd} = +3.5V^*$, $I_{dd} = 300 mA$

Parameter	Min.	Typ.	Max.	Min.	Typ.	Max.	Units
Frequency Range	17 - 40			21 - 30			GHz
Gain	15	20		17	22		dB
Gain Variation over Temperature		0.05	0.07		0.05	0.07	dB/°C
Input Return Loss	6	10		6	12		dB
Output Return Loss	4	7		4	8		dB
Reverse Isolation	30	40		35	45		dB
Output Power for 1 dB Compression (P1dB)	14	18		14	18		dBm
Saturated Output Power (Psat)	17	21		17	21		dBm
Output Third Order Intercept (IP3)	22	27		21	27		dBm
Noise Figure		10			10		dB
Supply Current (Idd)		300	330		300	330	mA

*Vdd = +3.5V, adjust Vgg = Vgg1, Vgg2 between -2.0 to +0.4V to achieve Idd = 300 mA typical.



SMT MEDIUM POWER GaAs MMIC AMPLIFIER, 17 - 40 GHz

Broadband Gain & Return Loss

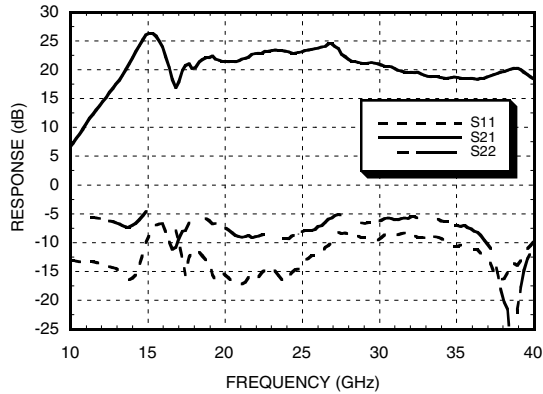

Gain vs. Temperature

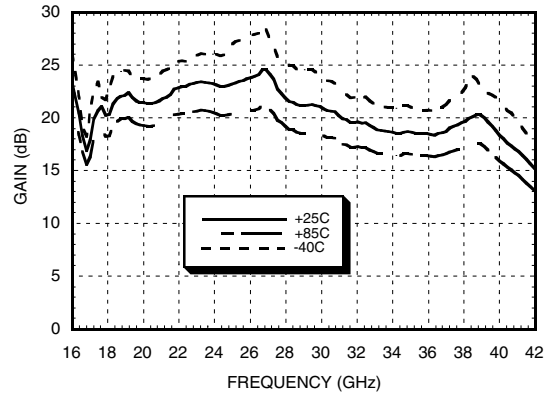

Reverse Isolation vs. Temperature

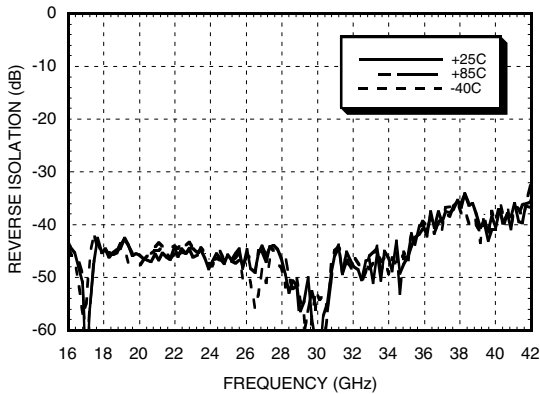

Input Return Loss vs. Temperature

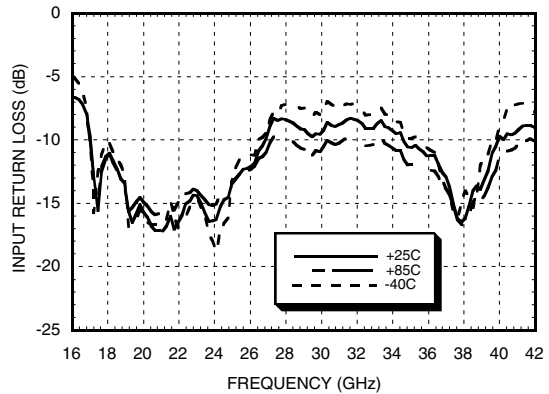

P1dB and Psat @ 25 °C

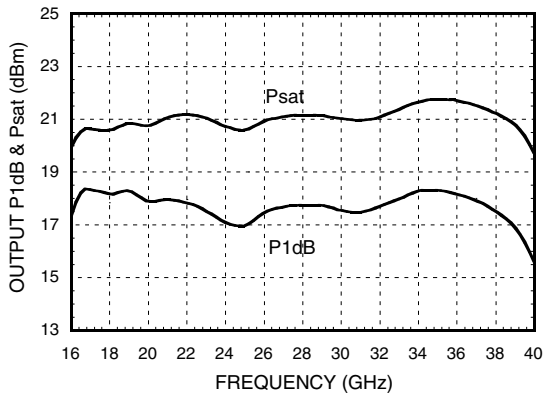

Output Return Loss vs. Temperature

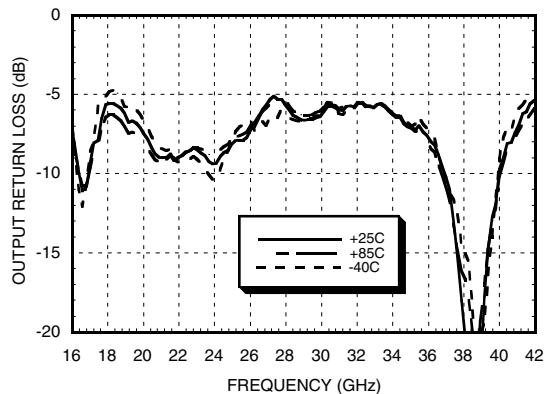

SMT MEDIUM POWER GaAs MMIC AMPLIFIER, 17 - 40 GHz

P1dB vs. Temperature

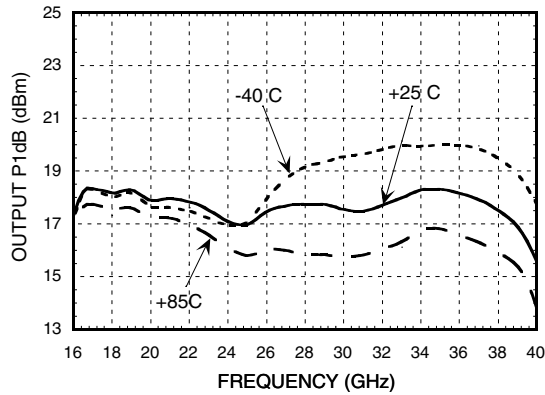

Power Compression @ 20 GHz

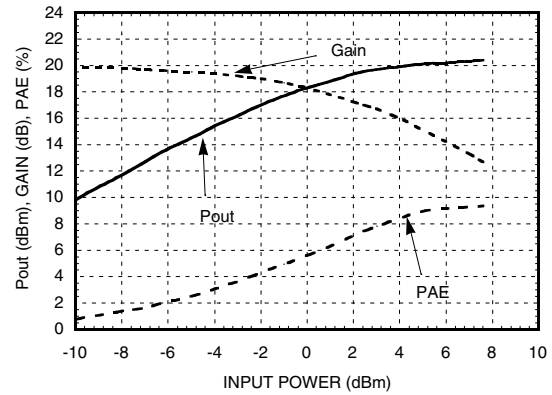

Psat vs. Temperature

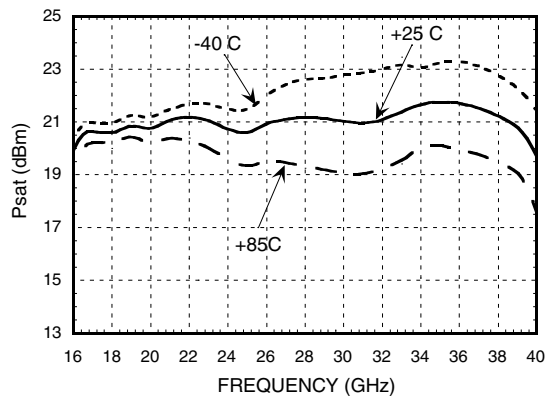

Power Compression @ 28 GHz

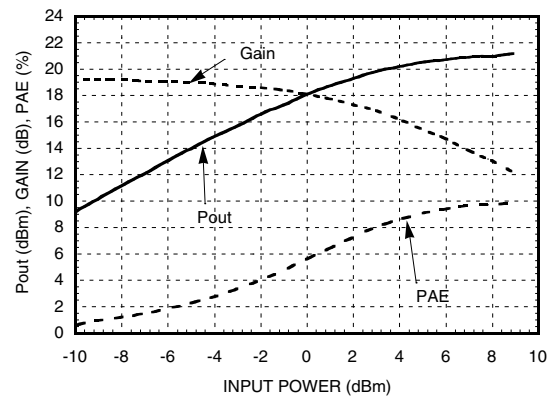

Output IP3 vs. Temperature

Temperature	Frequency (GHz)		
	20	28	38
-40 °C	29.0	28.0	31.0
+25 °C	28.5	27.5	28.5
+85 °C	27.5	26.0	24.5

All levels in dBm

Power Compression @ 39 GHz

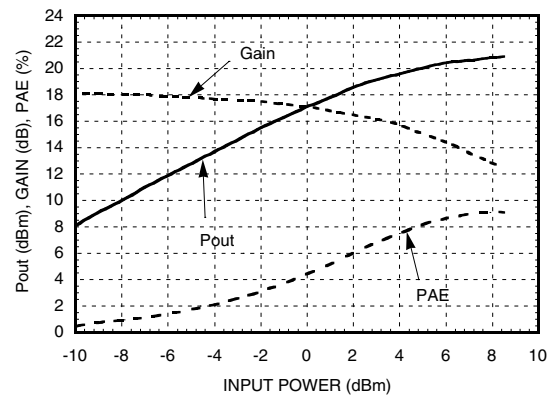

SMT MEDIUM POWER GaAs MMIC AMPLIFIER, 17 - 40 GHz

Absolute Maximum Ratings

Drain Bias Voltage (Vdd)	+5.0 Vdc
Drain Bias Current (Idd)	400 mA
Gate Bias Voltage (Vgg1, Vgg2)	-2.0 to +0.4 Vdc
Gate Bias Current (Igg)	4.0 mA
RF Input Power (RFIn)(Vdd = +3.5 Vdc)	+10 dBm
Channel Temperature	175 °C
Continuous Pdiss (T = 85 °C) (derate 16 mW/°C above 85 °C)	1.44 W
Thermal Resistance (channel to ground paddle)	62.5 °C/W
Storage Temperature	-65 to +150 °C
Operating Temperature	-40 to +85 °C

Outline Drawing

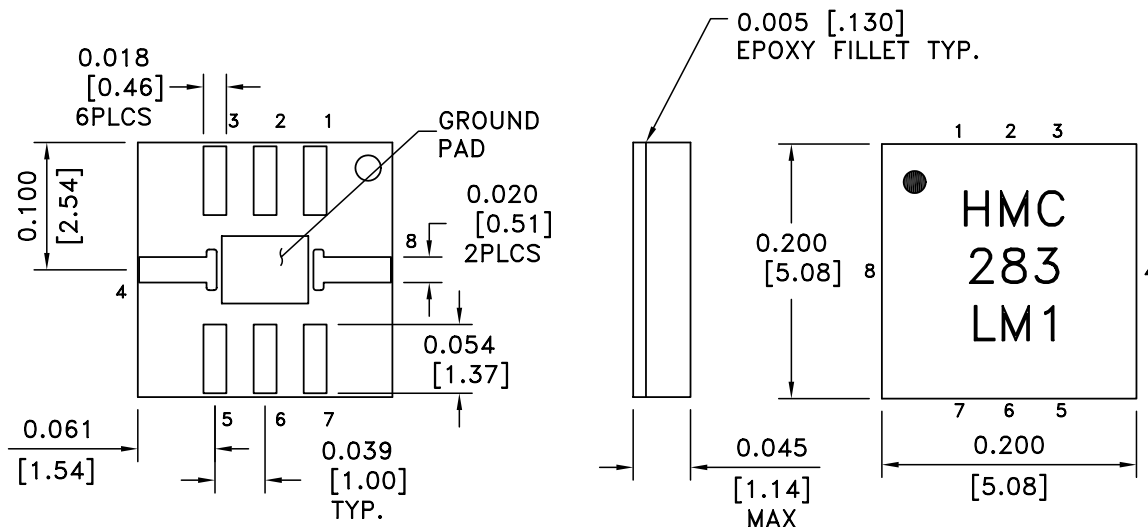

Pin	Function
1	GND
2	Vdd
3	GND
4	RF OUT
5	VDET
6	Vgg2
7	Vgg1
8	RF IN

NOTES:

1. MATERIAL: PLASTIC
2. PLATING: GOLD OVER NICKEL
3. DIMENSIONS ARE IN INCHES [MILLIMETERS].
4. ALL TOLERANCES ARE ± 0.005 [± 0.13].
5. ALL GROUNDS MUST BE SOLDERED TO PCB RF GROUND.
6. ● INDICATES PIN 1

SMT MEDIUM POWER GaAs MMIC AMPLIFIER, 17 - 40 GHz

Evaluation PCB

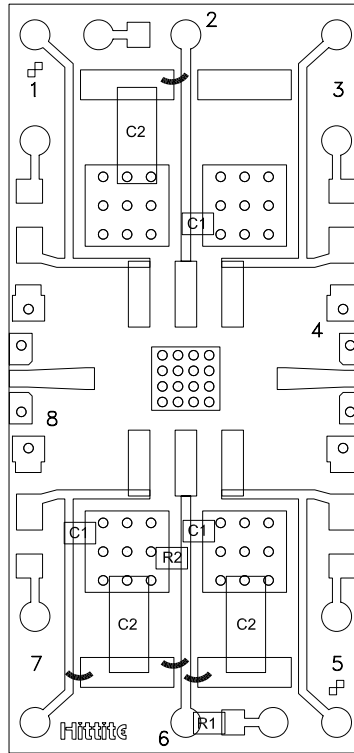

LM1 Evaluation PCB

The grounded Co-Planar Wave Guide (CPWG) PCB input/output transitions allow use of Ground-Signal-Ground (GSG) probes for testing. Suggested probe pitch is 400um (16 mils). Alternatively, the board can be mounted in a metal housing with 2.4 mm coaxial connectors.

Evaluation Circuit Board Layout Design Details

Layout Technique	Micro Strip to CPWG
Material	Rogers 4003 with 1/2 oz. Cu
Dielectric Thickness	0.008" (0.20 mm)
Microstrip Line Width	0.018" (0.46 mm)
CPWG Line Width	0.016" (0.41 mm)
CPWG Line to GND Gap	0.005" (0.13 mm)
Ground Via Hole Diameter	0.008" (0.20 mm)
C1	100 pF Capacitor, 0402 Pkg.
C2	33,000 pF Capacitor, 1206 Pkg.
R1	1,000 Ohm Resistor, 0402 Pkg.
R2	100 Ohm Resistor, 0402 Pkg.

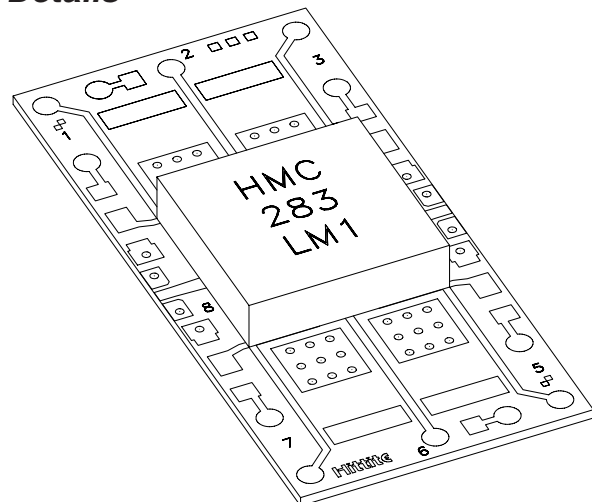

LM1 Package Mounted to Evaluation PCB

SMT MEDIUM POWER GaAs MMIC AMPLIFIER, 17 - 40 GHz

Suggested LM1 PCB Land Pattern Tolerance: ± 0.003" (± 0.08 mm)

UPDATED 12-5-01

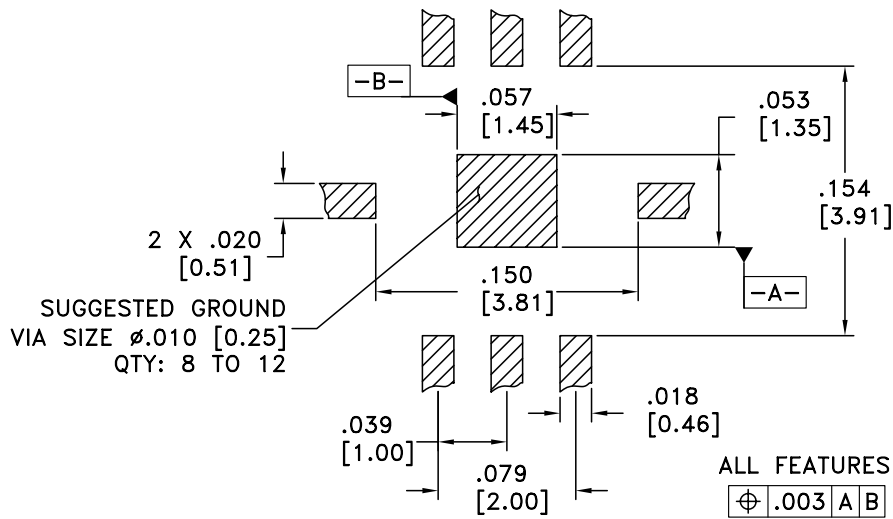

Amplifier Application Circuit

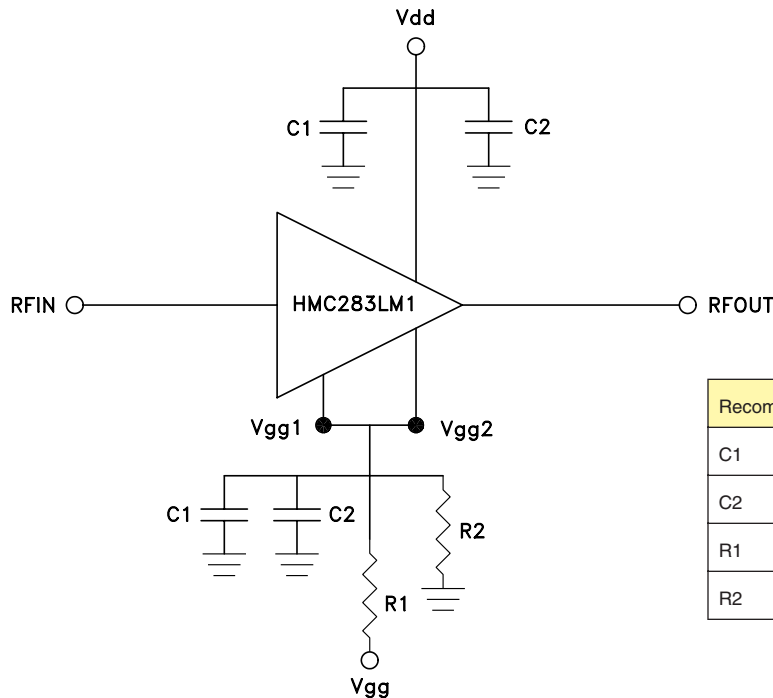

Recommended Component Values	
C1	100 pF
C2	33,000 pF
R1	1,000 Ohm
R2	100 Ohm

Note: Vgg1 and Vgg2 may be connected to a common Vgg feed. For optimal stable operation, it is recommended that a voltage divider network be employed as shown above with Vgg set to achieve I_{dd} = 300 mA typical.

**SMT MEDIUM POWER GaAs MMIC
AMPLIFIER, 17 - 40 GHz****Recommended SMT Attachment Technique****Preparation & Handling of the LM1 Millimeterwave Package for Surface Mounting**

The HMC LM1 package was designed to be compatible with high volume surface mount PCB assembly processes. The LM1 package requires a specific mounting pattern to allow proper mechanical attachment and to optimize electrical performance at millimeterwave frequencies. The PCB layout pattern can be found on each LM1 product data sheet. It can also be provided as an electronic drawing upon request from Hittite Sales & Application Engineering.

Follow these precautions to avoid permanent damage:
Cleanliness: Observe proper handling procedures to ensure clean devices and PCBs. LM1 devices should remain in their original packaging until component placement to ensure no contamination or damage to RF, DC & ground contact areas.

Static Sensitivity: Follow ESD precautions to protect against ESD strikes.

General Handling: Handle the LM1 package on the top with a vacuum collet or along the edges with a sharp pair of bent tweezers. Avoid damaging the RF, DC, & ground contacts on the package bottom. Do not apply excess pressure to the top of the lid.

Solder Materials & Temperature Profile: Follow the information contained in the application note. Hand soldering is not recommended. Conductive epoxy attachment is not recommended.

Solder Paste

Solder paste should be selected based on the user's experience and should be compatible with the metallization systems used. See the LM1 data sheet Outline drawing for pin & ground contact metallization schemes.

Solder Paste Application

Solder paste is generally applied to the PCB using either a stencil printer or dot placement. The volume of solder paste will be dependent on PCB and component layout and should be controlled to ensure consistent mechanical & electrical performance. Excess solder may create unwanted electrical parasitics at high frequencies.

Solder Reflow

The soldering process is usually accomplished in a reflow oven but may also use a vapor phase process. A solder reflow profile is suggested above.

Prior to reflowing product, temperature profiles should be measured using the same mass as the actual assemblies. The thermocouple should be moved to various positions on the board to account for edge and corner effects and varying component masses. The final profile should be determined by mounting the thermocouple to the PCB at the location of the device.

Follow solder paste and oven vendor's recommendations when developing a solder reflow profile. A standard profile will have a steady ramp up from room temperature to the pre-heat temperature to avoid damage due to thermal shock. Allow enough time between reaching pre-heat temperature and reflow for the solvent in the paste to evaporate and the flux to completely activate. Reflow must then occur prior to the flux being completely driven off. The duration of peak reflow temperature should not exceed 15 seconds. Packages have been qualified to withstand a peak temperature of 235°C for 15 seconds. Verify that the profile will not expose the device to temperatures in excess of 235°C.

Cleaning

A water-based flux wash may be used.

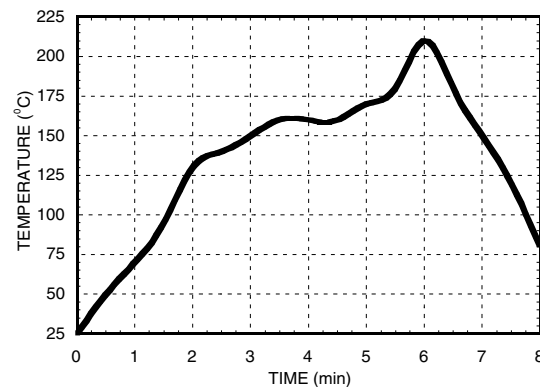

**Recommended solder reflow profile
for HMC LM1 SMT package**

SMT MEDIUM POWER GaAs AMPLIFIER, 17 - 40 GHz

Alternate Applications: Frequency Multiplier Performance

HMC283LM1 can also perform as a frequency multiplier. This is accomplished by biasing V_{g1} into its pinchoff region - typically -1V to -2V. By adjusting the V_{g1} bias, the device will operate as a doubler or tripler. V_{g2} may also be adjusted to minimize the levels of unwanted harmonics. The plot shows the performance of HMC283 operated as a doubler with $V_{g1} = -1V$ and the remaining gate voltages ($V_{g2}, 3, 4$) set to -0.15V. In this condition the amplifier draws 310mA at 3.5V drain bias (V_{dd}) and provides +5dB to -5dB conversion loss dependent upon the output frequency.

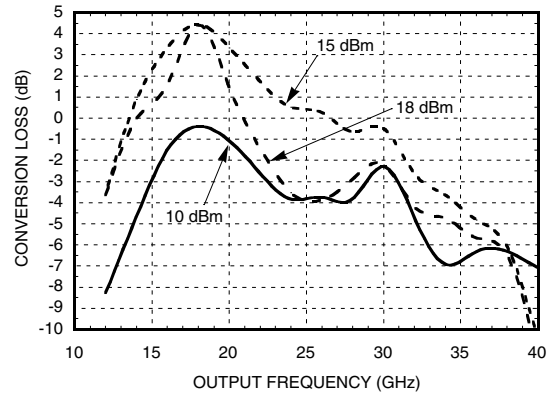

Voltage Detector, Built-In-Test (B.I.T.)

By connecting the V_{det} port to a 10k Ohm resistor and monitoring the voltage, a B.I.T. circuit can be created to monitor changes in the device output power. This circuit is extremely well compensated for temperature variations as shown in the first plot. The detected voltage does change with frequency and the second plot shows its variation.

