



v02.1202

HMC327MS8G

GaAs InGaP HBT MMIC POWER AMPLIFIER, 3.0 - 4.0 GHz

Typical Applications

This amplifier is ideal for use as a power amplifier for 3.3 - 3.6 GHz applications:

- Wireless Local Loop

Features

- Gain: 21 dB
- Saturated Power: +30 dBm
- 45% PAE
- Supply Voltage: +5.0 V
- Power Down Capability
- Low External Part Count

Functional Diagram

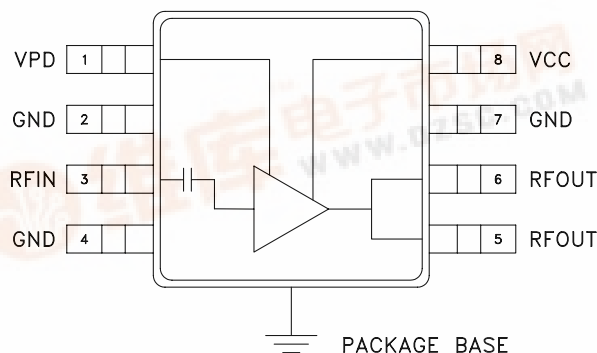

General Description

The HMC327MS8G is a high efficiency GaAs InGaP Heterojunction Bipolar Transistor (HBT) MMIC Power amplifier which operates between 3.0 and 4.0 GHz. The amplifier is packaged in a low cost, surface mount 8 leaded package with an exposed base for improved RF and thermal performance. With a minimum of external components, the amplifier provides 21 dB of gain, +30 dBm of saturated power at 45% PAE from a +5.0V supply voltage. Power down capability is available to conserve current consumption when the amplifier is not in use.

Electrical Specifications, $T_A = +25^\circ C$, $V_s = 5V$, $V_{ctl} = 5V$

Parameter	Min.	Typ.	Max.	Units
Frequency Range	3.0 - 4.0			GHz
Gain	17	21	24	dB
Gain Variation Over Temperature		0.025	0.035	dB / °C
Input Return Loss		15		dB
Output Return Loss		8		dB
Output Power for 1dB Compression (P1dB)	24	27		dBm
Saturated Output Power (Psat)		30		dBm
Output Third Order Intercept (IP3)	36	40		dBm
Noise Figure		5.0		dB
Supply Current (Icq)	Vpd = 0V/5V		0.002 / 250	mA
Control Current (Ipd)	Vpd = 5V		7	mA
Switching Speed	tON, tOFF		40	ns



GaAs InGaP HBT MMIC POWER AMPLIFIER, 3.0 - 4.0 GHz

Broadband Gain & Return Loss

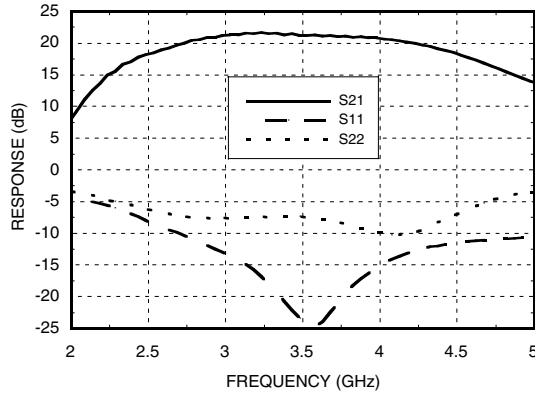

Gain vs. Temperature

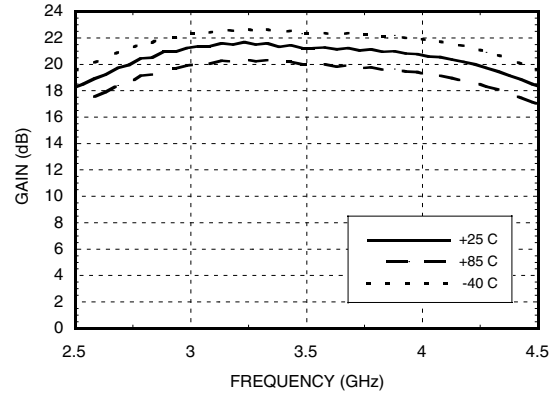

Input Return Loss vs. Temperature

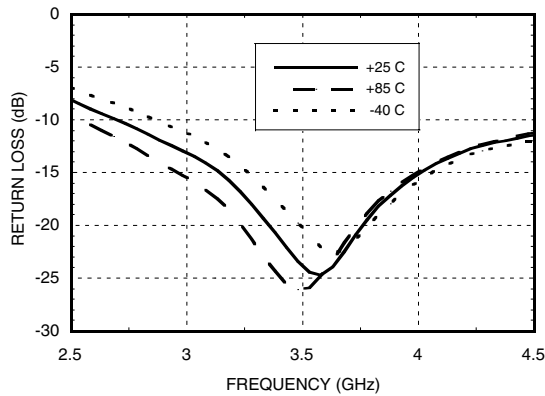

Output Return Loss vs. Temperature

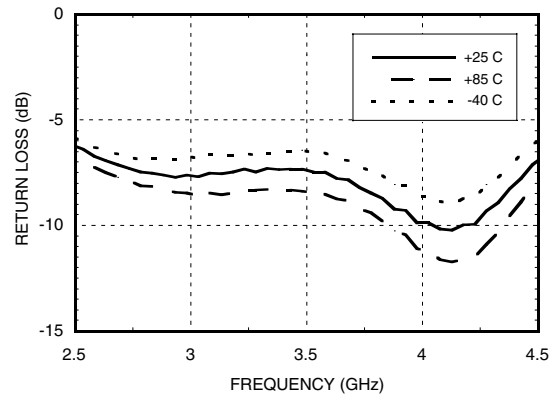

P1dB vs. Temperature

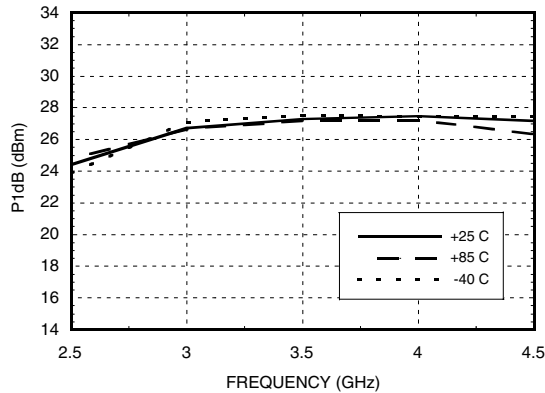

Psat vs. Temperature

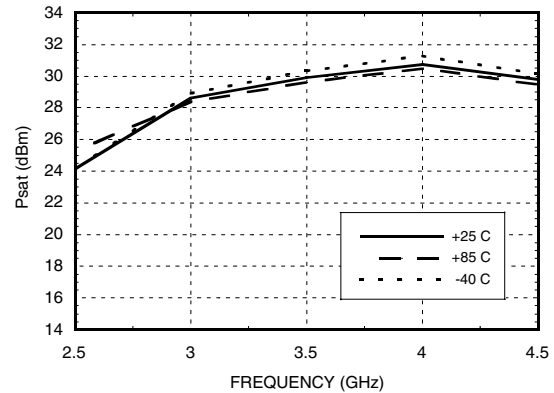

GaAs InGaP HBT MMIC POWER AMPLIFIER, 3.0 - 4.0 GHz

Power Compression @ 3.5 GHz

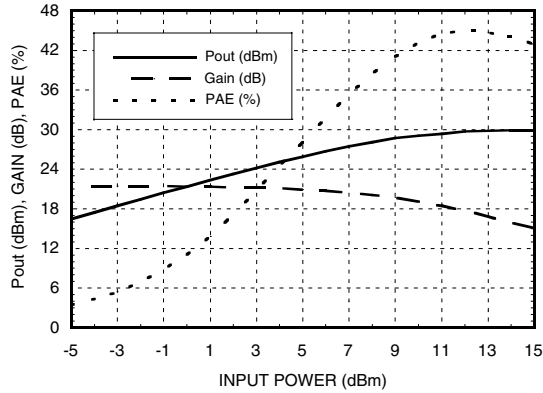

Output IP3 vs. Temperature

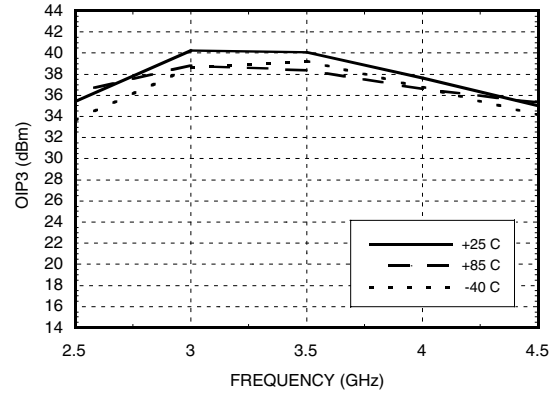

Noise Figure vs. Temperature

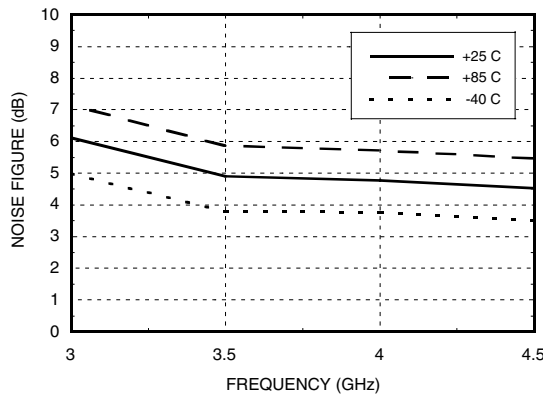

Gain & Power vs. Supply Voltage

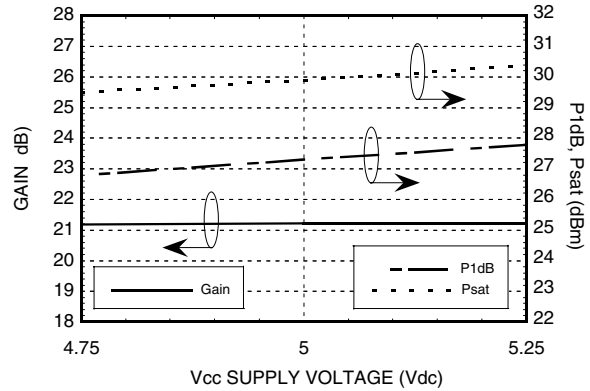

Reverse Isolation vs. Temperature

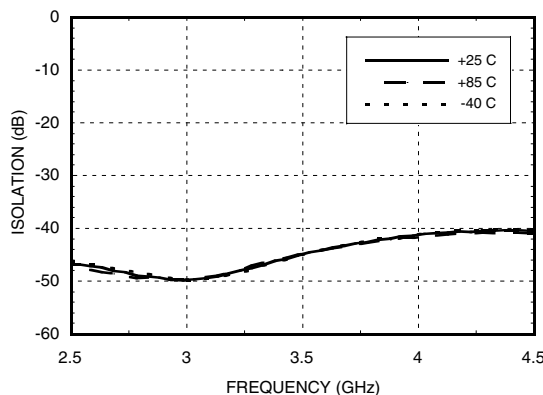

Power Down Isolation

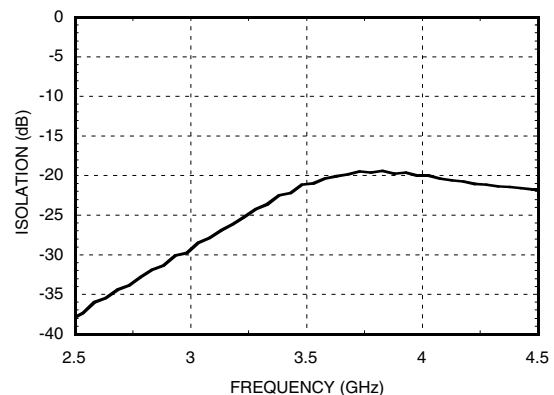

GaAs InGaP HBT MMIC POWER AMPLIFIER, 3.0 - 4.0 GHz

Gain, Power & Quiescent Supply Current vs. Vpd @ 3.5 GHz

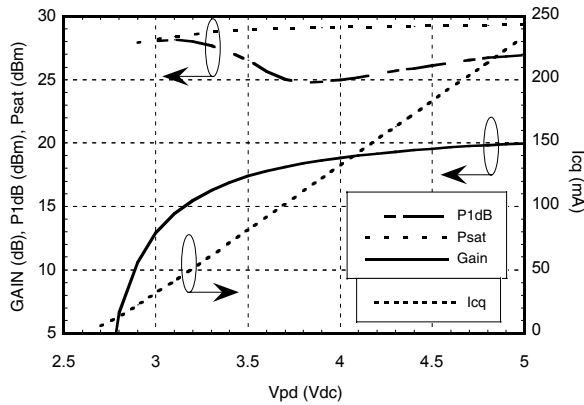

Absolute Maximum Ratings

Collector Bias Voltage (Vcc)	+5.5 Vdc
Control Voltage (Vpd)	+5.5 Vdc
RF Input Power (RFIn)(Vs = Vctl = +5.0 Vdc)	+20 dBm
Junction Temperature	150 °C
Continuous Pdiss (T = 85 °C) (derate 29 mW/°C above 85 °C)	1.88 W
Thermal Resistance (junction to ground paddle)	34 °C/W
Storage Temperature	-65 to +150 °C
Operating Temperature	-40 to +85 °C

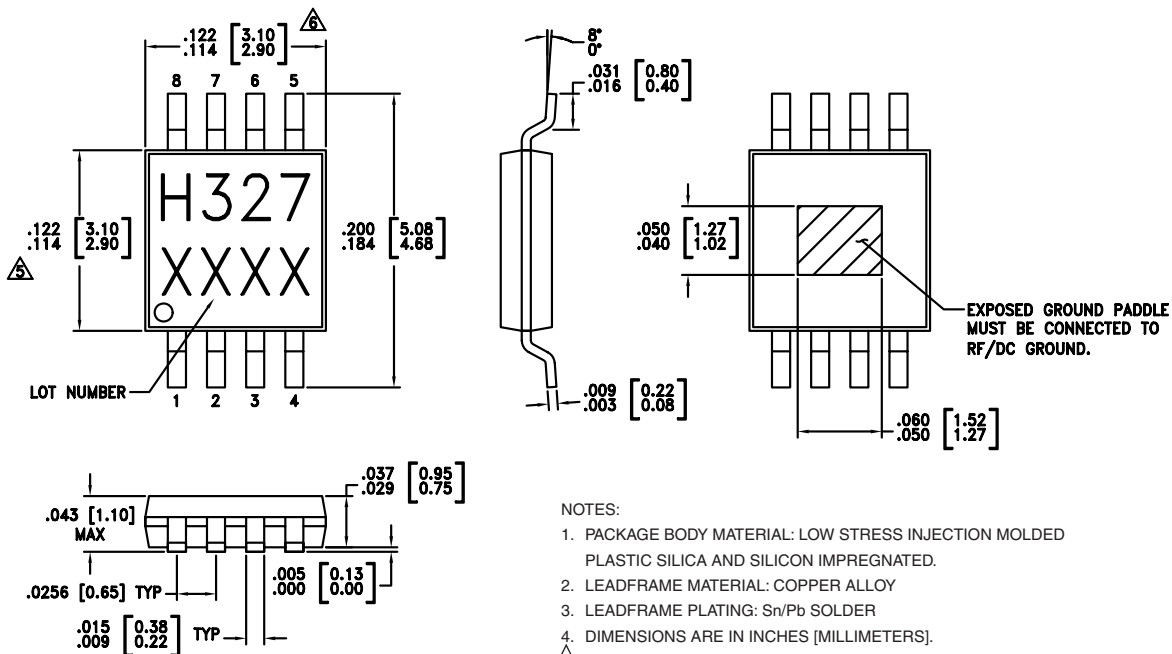

Outline Drawing



- NOTES:
1. PACKAGE BODY MATERIAL: LOW STRESS INJECTION MOLDED PLASTIC SILICA AND SILICON IMPREGNATED.
 2. LEADFRAME MATERIAL: COPPER ALLOY
 3. LEADFRAME PLATING: Sn/Pb SOLDER
 4. DIMENSIONS ARE IN INCHES [MILLIMETERS].
 5. DIMENSION DOES NOT INCLUDE MOLDFLASH OF 0.15mm PER SIDE.
 6. DIMENSION DOES NOT INCLUDE MOLDFLASH OF 0.25mm PER SIDE.
 7. ALL GROUND LEADS AND GROUND PADDLE MUST BE SOLDERED TO PCB RF GROUND.

GaAs InGaP HBT MMIC POWER AMPLIFIER, 3.0 - 4.0 GHz

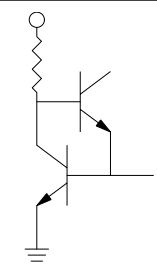
Pin Descriptions

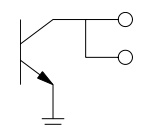
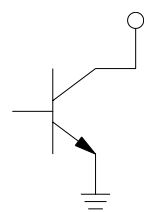
Pin Number	Function	Description	Interface Schematic
1	Vpd	Power Control Pin. For maximum power, this pin should be connected to 5.0V. A higher voltage is not recommended. For lower idle current, this voltage can be reduced.	
2, 4, 7	GND	Ground: Backside of package has exposed metal ground slug that must be connected to ground thru a short path. Vias under the device are required.	
3	RF IN	This pin is AC coupled and matched to 50 Ohms from 3.0 to 4.0 GHz.	
5, 6	RF OUT	RF output and bias for the output stage. The power supply for the output device needs to be supplied to these pins.	
8	Vcc	Power supply voltage for the first amplifier stage. An external bypass capacitor of 330 pF is required. This capacitor should be placed as close to the device as possible.	

GaAs InGaP HBT MMIC POWER AMPLIFIER, 3.0 - 4.0 GHz

Evaluation PCB

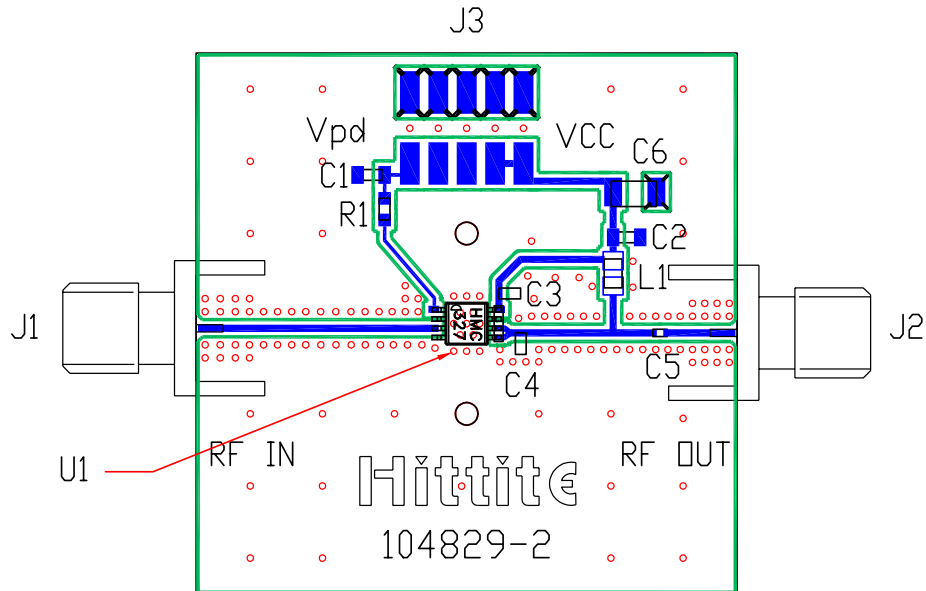

List of Material

Item	Description
J1 - J2	PC Mount SMA RF Connector
J3	2 mm DC Header
C1 - C3	330 pF Capacitor, 0603 Pkg.
C4	1.2 pF Capacitor, 0603 Pkg.
C5	2.0 pF Capacitor, 0402 Pkg.
C6	2.2 μ F Capacitor, Tantalum
L1	3.0 nH Inductor, 0805 Pkg.
R1	130 Ohm Resistor, 0603 Pkg.
U1	HMC327MS8G Amplifier
PCB*	104829 Eval Board
* Circuit Board Material: Rogers 4350	

The circuit board used in the final application should use RF circuit design techniques. Signal lines should have 50 ohm impedance while the package ground leads and exposed paddle should be connected directly to the ground plane similar to that shown. A sufficient number of VIA holes should be used to connect the top and bottom ground planes. The evaluation board should be mounted to an appropriate heat sink. The evaluation circuit board shown is available from Hittite upon request.

GaAs InGaP HBT MMIC POWER AMPLIFIER, 3.0 - 4.0 GHz

Application Circuit

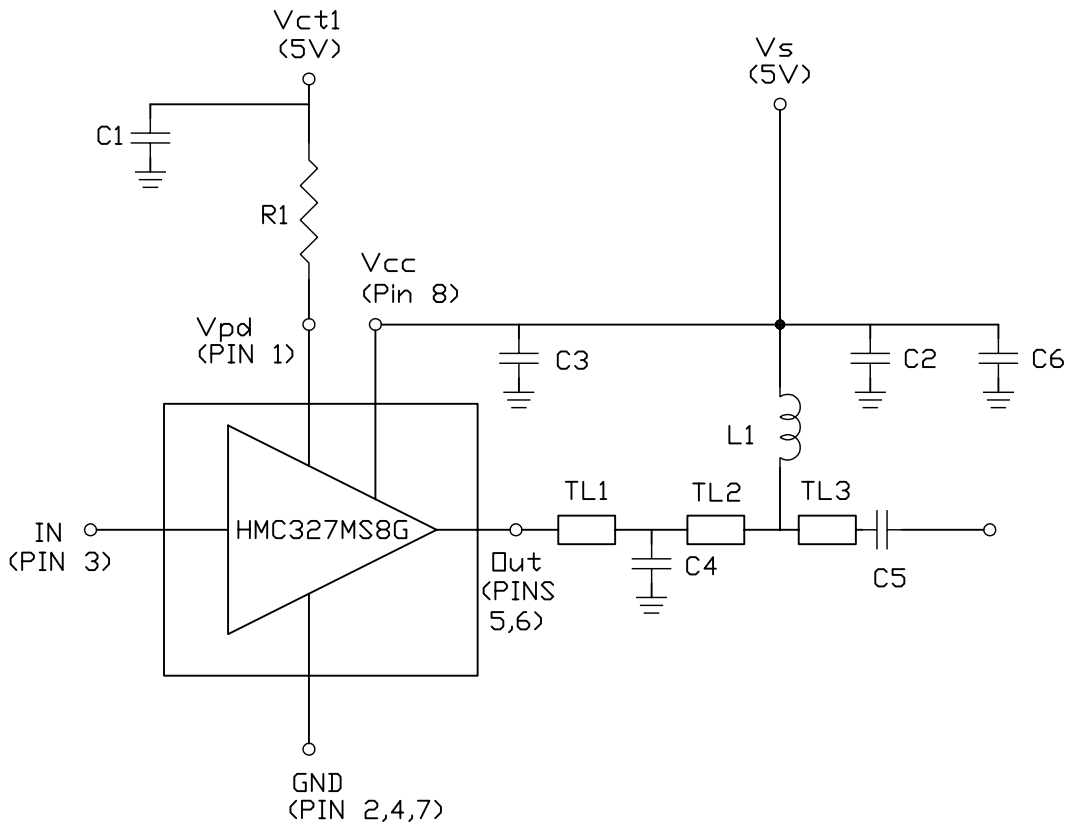

Note 1: C3 should be located < 0.020" from Pin 8 (Vcc)

Note 2: C2 should be located < 0.020" from L1.

	TL1	TL2	TL3
Impedance	50 Ohm	50 Ohm	50 Ohm
Length	0.038"	0.231"	0.1"



v02.1202

HMC327MS8G

***GaAs InGaP HBT MMIC
POWER AMPLIFIER, 3.0 - 4.0 GHz***

Notes:

8

AMPLIFIERS - SMT