

MAGNACHIP SEMICONDUCTOR LTD.  
8-BIT SINGLE-CHIP MICROCONTROLLERS

**HMS87C1808B/16B**

**HMS87C1708B/16B**

**HMS87C1608B/16B**

**HMS87C1508B/16B**

**HMS87C1404B/08B/16B**

*User's Manual (Ver. 1.03)*



## **REVISION HISTORY**

### **VERSION 1.03 (SEP. 2004) This book**

The company name, Hynix Semiconductor Inc. changed to MagnaChip Semiconductor Ltd.

### **VERSION 1.02 (MAR. 2004)**

Correct the external RC oscillation characteristics  
Fixed some errata.

### **VERSION 1.01 (MAY. 2003)**

Fixed some errata.

---

### **Version 1.03**

**Published by**  
**MCU Application Team**

**©2004 MagnaChip Semiconductor Ltd. All right reserved.**

---

Additional information of this manual may be served by MagnaChip Semiconductor offices in Korea or Distributors and Representatives.

MagnaChip Semiconductor reserves the right to make changes to any information here in at any time without notice.

The information, diagrams and other data in this manual are correct and reliable; however, MagnaChip Semiconductor is in no way responsible for any violations of patents or other rights of the third party generated by the use of this manual.

<b>1. OVERVIEW</b> .....	<b>1</b>	8-bit Timer/Counter Mode .....	45
Description .....	1	16-bit Timer/Counter Mode .....	46
Features .....	1	8-bit Compare Output (16-bit) .....	47
Development Tools .....	2	8-bit Capture Mode .....	47
Ordering Information .....	3	16-bit Capture Mode .....	50
<b>2. BLOCK DIAGRAM</b> .....	<b>4</b>	PWM Mode .....	50
<b>3. PIN ASSIGNMENT</b> .....	<b>5</b>	<b>13. Serial Peripheral Interface</b> .....	<b>53</b>
<b>4. PACKAGE DRAWING</b> .....	<b>7</b>	<b>14. Buzzer Output function</b> .....	<b>55</b>
<b>5. PIN FUNCTION</b> .....	<b>10</b>	<b>15. ANALOG TO DIGITAL CONVERTER</b> .....	<b>56</b>
<b>6. PORT STRUCTURES</b> .....	<b>12</b>	<b>16. INTERRUPTS</b> .....	<b>59</b>
<b>7. ELECTRICAL CHARACTERISTICS</b> .....	<b>17</b>	Interrupt Sequence .....	61
Absolute Maximum Ratings .....	17	BRK Interrupt .....	62
Recommended Operating Conditions .....	17	Multi Interrupt .....	62
A/D Converter Characteristics .....	17	External Interrupt .....	64
DC Electrical Characteristics .....	18	<b>17. WATCHDOG TIMER</b> .....	<b>66</b>
AC Characteristics .....	19	<b>18. Power Saving Mode</b> .....	<b>67</b>
Typical Characteristics .....	20	Stop Mode .....	67
<b>8. MEMORY ORGANIZATION</b> .....	<b>23</b>	STOP Mode using Internal RCWDT .....	69
Registers .....	23	Wake-up Timer Mode .....	70
Program Memory .....	25	Minimizing Current Consumption .....	71
Data Memory .....	28	<b>19. RESET</b> .....	<b>73</b>
Addressing Mode .....	32	<b>20. POWER FAIL PROCESSOR</b> .....	<b>75</b>
<b>9. I/O PORTS</b> .....	<b>36</b>	<b>21. COUNTERMEASURE OF NOISE</b> .....	<b>77</b>
RA and RAIO registers .....	36	Oscillation Noise Protector .....	77
RB and RBIO registers .....	37	Oscillation Fail Processor .....	78
RC and RCIO registers .....	39	Device Configuration Area .....	78
RD and RDIO registers .....	40	Examples of ONP .....	79
RE and REIO registers .....	40	<b>22. OTP PROGRAMMING</b> .....	<b>80</b>
<b>10. CLOCK GENERATOR</b> .....	<b>41</b>	EPROM Mode .....	80
Oscillation Circuit .....	41	<b>23. APPENDIX</b> .....	<b>i</b>
<b>11. Basic Interval Timer</b> .....	<b>43</b>	A. INSTRUCTION MAP .....	i
<b>12. TIMER / COUNTER</b> .....	<b>44</b>	B. INSTRUCTION SET .....	ii



# HMS87C1808B / 16B HMS87C1708B / 16B HMS87C1608B / 16B HMS87C1508B / 16B HMS87C1404B / 08B / 16B

## CMOS SINGLE-CHIP 8-BIT MICROCONTROLLER

### 1. OVERVIEW

#### 1.1 Description

The HMS87C1X04B/08B/16B is an advanced CMOS 8-bit microcontroller with 4K/8K/16K bytes of ROM. The MagnaChip semiconductor's HMS87C1X04B/08B/16B is a powerful microcontroller which provides a highly flexible and cost effective solution to many embedded control applications. The HMS87C1X04B/08B/16B provides the following standard features: 4K/8K/16K bytes of ROM, 448 bytes of RAM, 8-bit timer/counter, 8-bit A/D converter, 10-bit high speed PWM output, programmable buzzer driving port, 8-bit serial communication port, on-chip oscillator and clock circuitry. In addition, the HMS87C1X04B/08B/16B support power saving modes to reduce power consumption.

This document is **only explained for the base HMS87C1816B**, the other's eliminated functions are same as below.

Device name	EPROM	RAM	EXT.INT	BUZ	Operating Voltage	I/O	Package
HMS87C14XXB	4,8,16K bytes	448bytes	4	O	2.3 ~ 5.5V	23	28 SKDIP or SOP
HMS87C15XXB	8,16K bytes					27	32 PDIP
HMS87C16XXB						35	40 PDIP
HMS87C17XXB						37	42 SDIP
HMS87C18XXB						39	44 QFP

#### 1.2 Features

- 4K/8K/16 Bytes On-chip Program Memory
- 448 Bytes of On-chip Data RAM (Included stack memory)
- Instruction Cycle Time:
  - 250nS at 8MHz
- Programmable I/O pins (LED direct driving can be source and sink)
  - HMS87C14XXB : 23
  - HMS87C15XXB : 27
  - HMS87C16XXB : 35
  - HMS87C17XXB : 37
  - HMS87C18XXB : 39
- Operating Voltage & Frequency
  - 2.3V ~ 5.5V (at 1 ~ 4.2MHz)
- 4.5V ~ 5.5V (at 1 ~ 8.0MHz)
- Eight 8-bit A/D Converter
- Four External Interrupt Ports.
- One 8-bit Basic Interval Timer
- Four 8-bit Timer / Counters
- Two 10-bit High Speed PWM Outputs
- Watchdog timer (can be operate with internal RC-oscillation)
- One 8-bit Serial Peripheral Interface
- Twelve Interrupt sources
  - External input: 4
  - A/D Conversion: 1

- Serial Peripheral Interface: 1
- Timer: 6
- One Programmable Buzzer Driving port
  - 500Hz ~ 130kHz
- Noise Immunity Circuit
  - Power Fail Processor
  - Oscillation Noise Protector
  - Oscillation Fail Processor

- Oscillator Type
  - Crystal
  - Ceramic Resonator
  - RC Oscillator ( C can be omitted )
  - Internal Oscillator ( approx. 4MHz )
- Power Down Mode
  - STOP mode
  - Wake-up Timer mode

**1.3 Development Tools**

The HMS87C1X04B/08B/16B is supported by a full-featured macro assembler, C compiler and an in-circuit emulator CHOICE-Dr™ and OTP programmers.

The macro assembler and C compiler operate under the MS-Windows 95/98, 2000, XP™.

The OTP programmer can be supplied three types of programmer such as emulator add-on board type single programmer (PGM-plus™), universal stand-alone type single programmer (CHOICE-SIGMA™) and gang type programmer (CHOICE-GANG4™).

<b>In Circuit Emulators</b>	CHOICE-Dr.™
<b>Assembler</b>	MagnaChip Macro Assembler
<b>OTP Programmer</b>	Single Programmer : PGM-plus™
	Universal Programmer : CHOICE-SIGMA™
	Gang Programmer : CHOICE-GANG4™

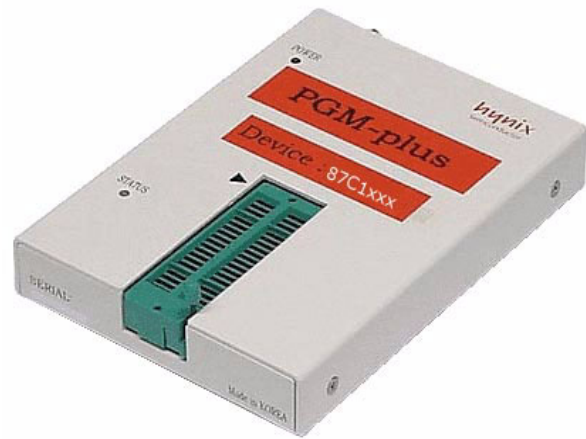

Figure 1-2 OTP Single Programmer PGM-plus™



Figure 1-1 In Circuit Emulator CHOICE-Dr.™

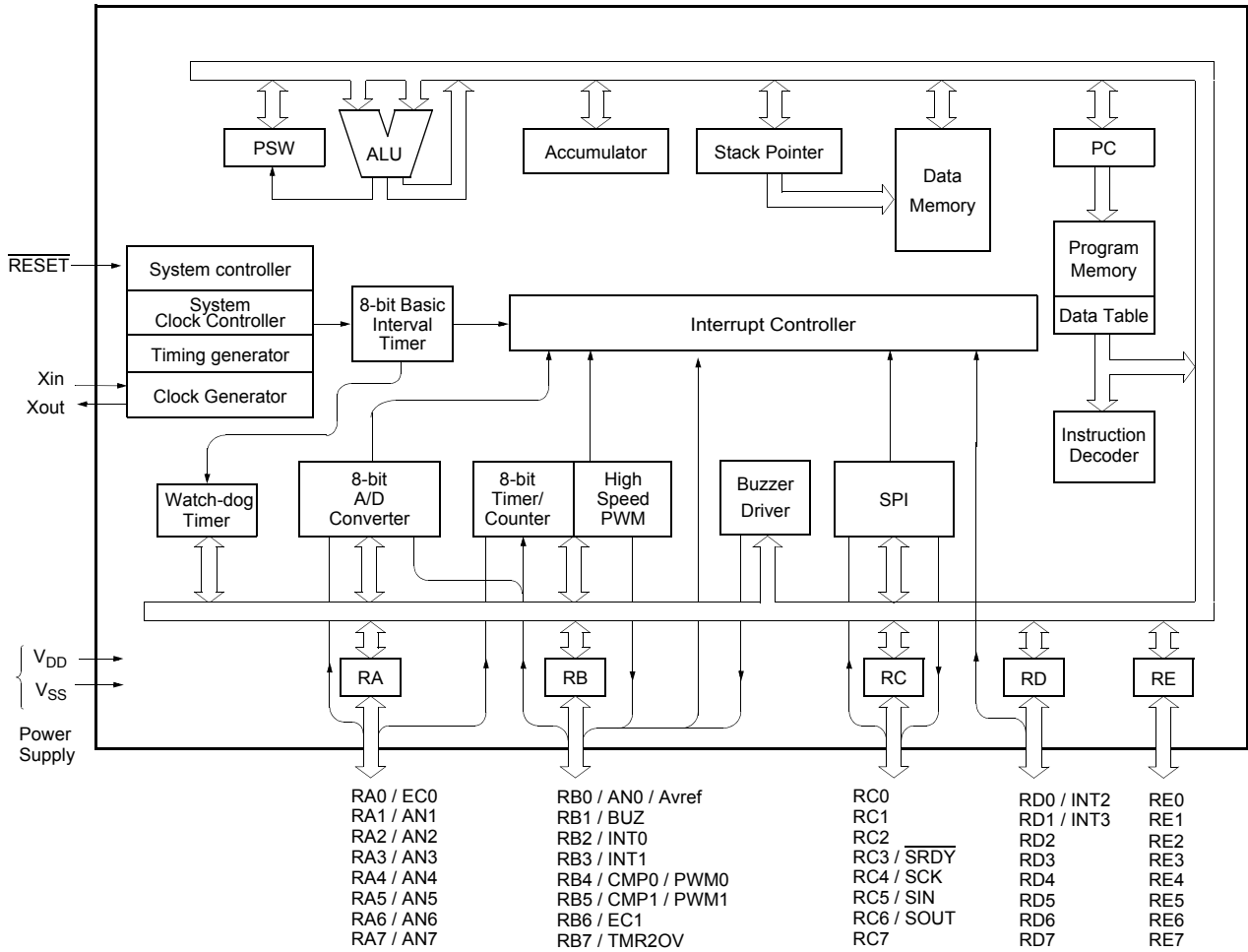

Figure 1-3 OTP Gang Programmer CHOICE-GANG4™

#### 1.4 Ordering Information

ROM Size	Package Type	Ordering Device Code	Operating Temperature
4K bytes (OTP)	28 SKDIP	HMS87C1404B SK	-40 ~ +85°C
	28 SOP	HMS87C1404B D	
8K bytes (OTP)	28 SKDIP	HMS87C1408B SK	
	28 SOP	HMS87C1408B D	
	32 PDIP	HMS87C1508B	
	40 PDIP	HMS87C1608B	
	42 SDIP	HMS87C1708B K	
	44 MQFP	HMS87C1808B Q	
16K bytes (OTP)	28 SKDIP	HMS87C1416B SK	
	28 SOP	HMS87C1416B D	
	32 PDIP	HMS87C1516B	
	40 PDIP	HMS87C1616B	
	42 SDIP	HMS87C1716B K	
	44 MQFP	HMS87C1816B Q	

2. BLOCK DIAGRAM





### 3. PIN ASSIGNMENT

#### HMS87C14XXB SK

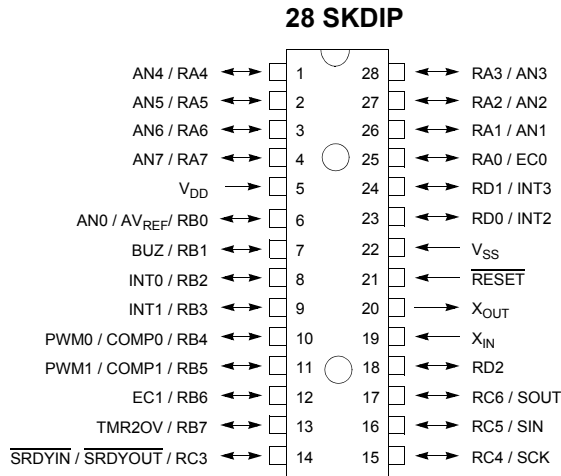

#### HMS87C14XXB D

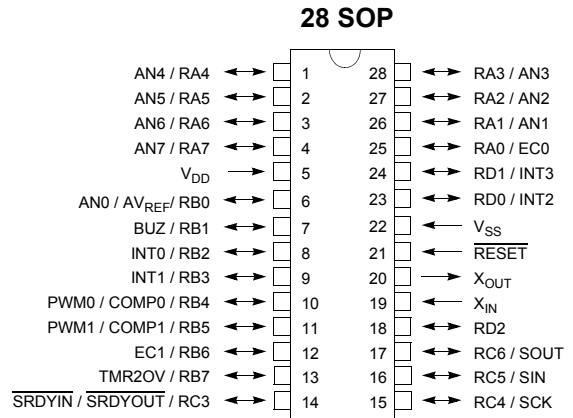

#### HMS87C15XXB

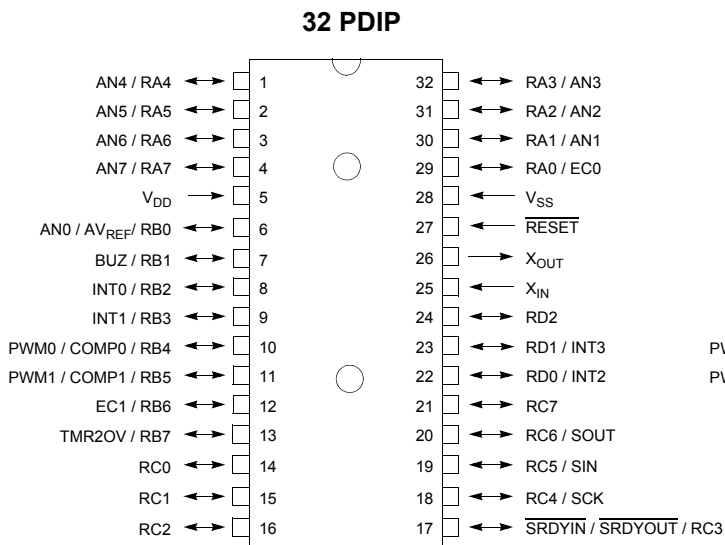

#### HMS87C16XXB

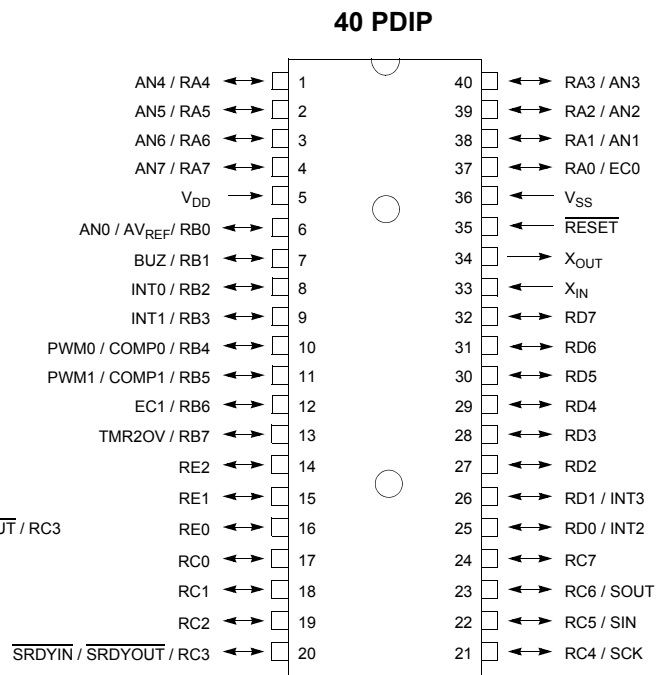

**HMS87C17XXB K**

**42 SDIP**

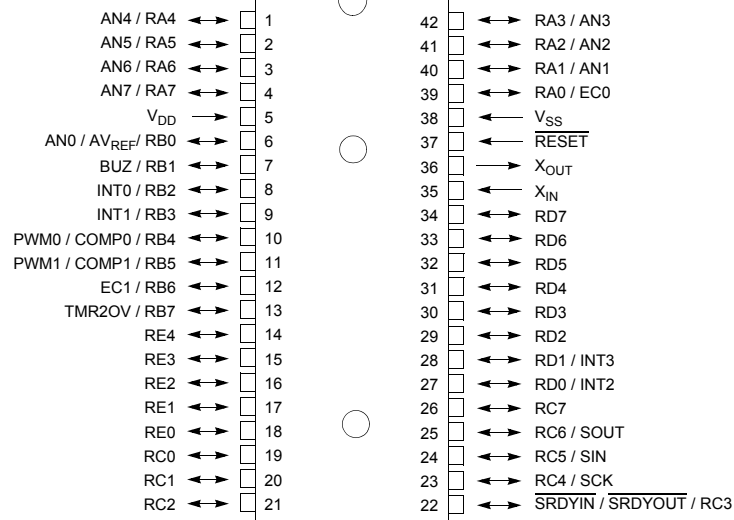

**HMS87C18XXB Q**

**44 MQFP**

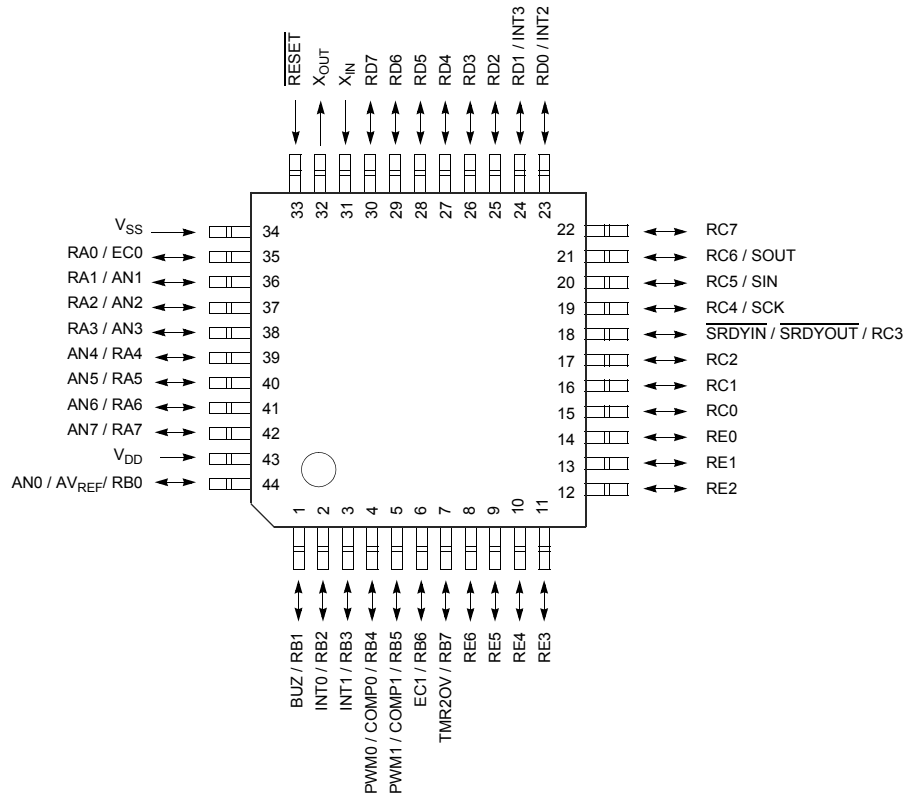

4. PACKAGE DRAWING

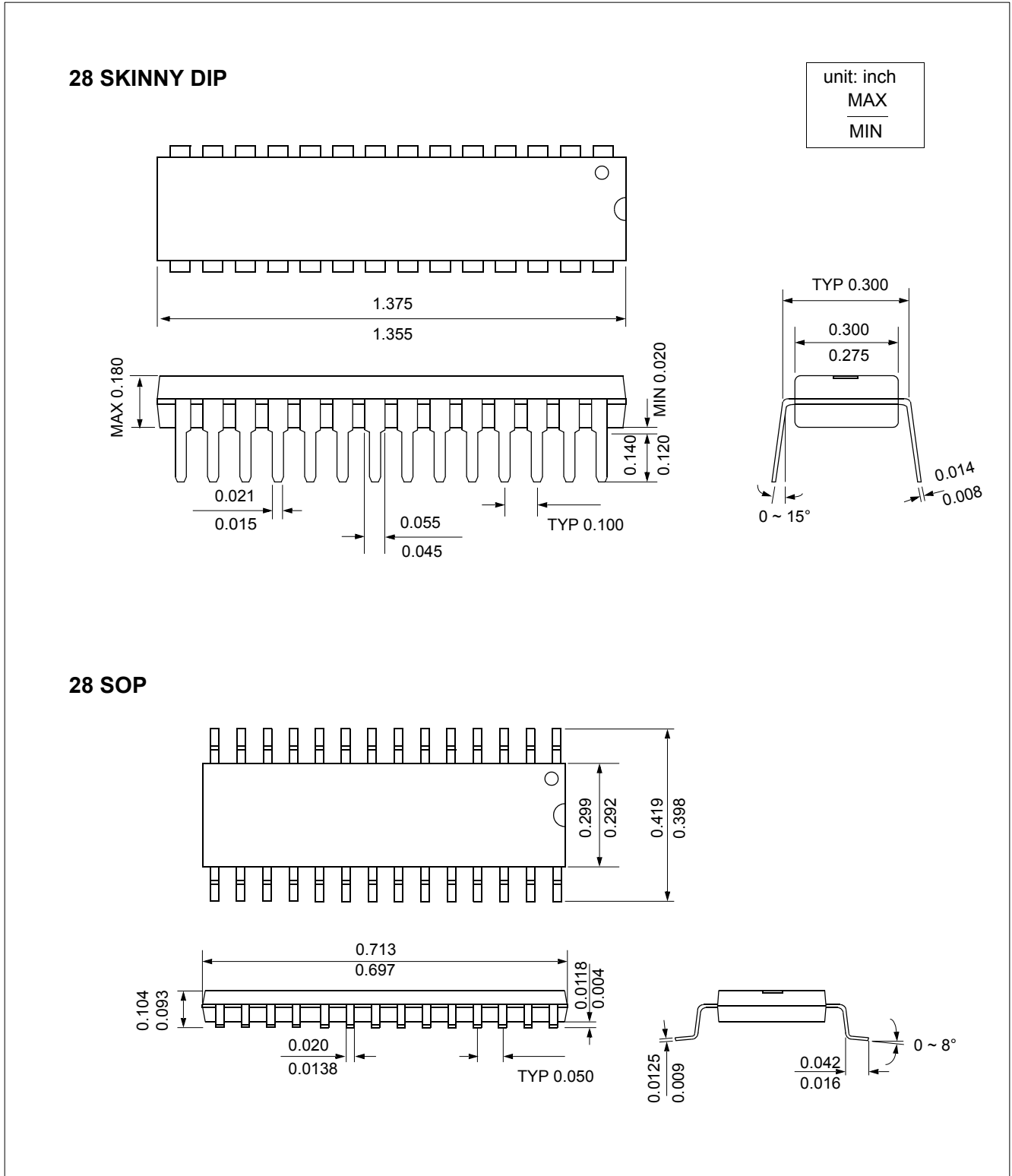

**32 PDIP**

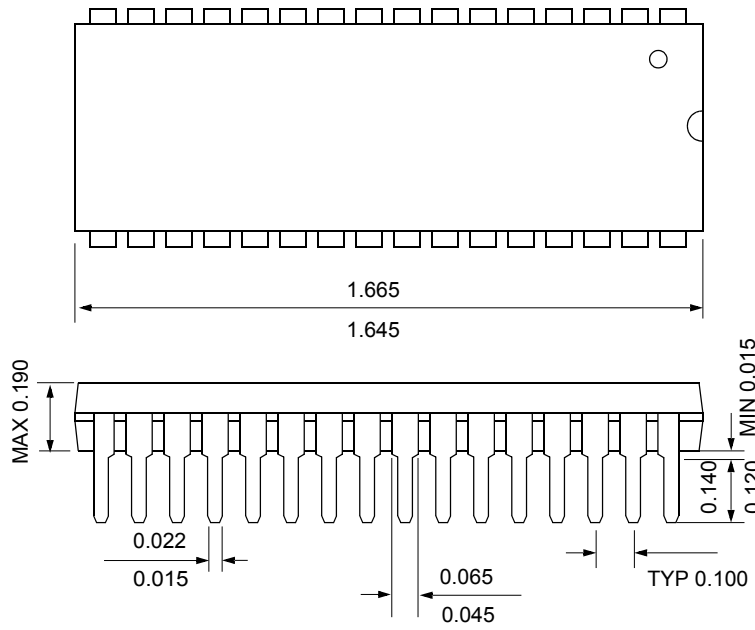

unit: inch  
MAX  
MIN

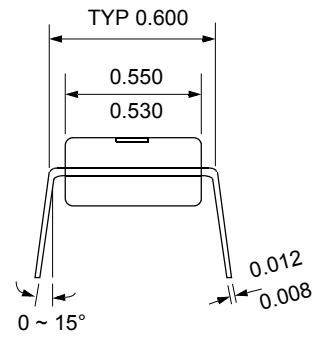

**40 PDIP**

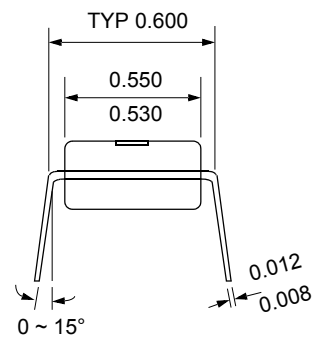
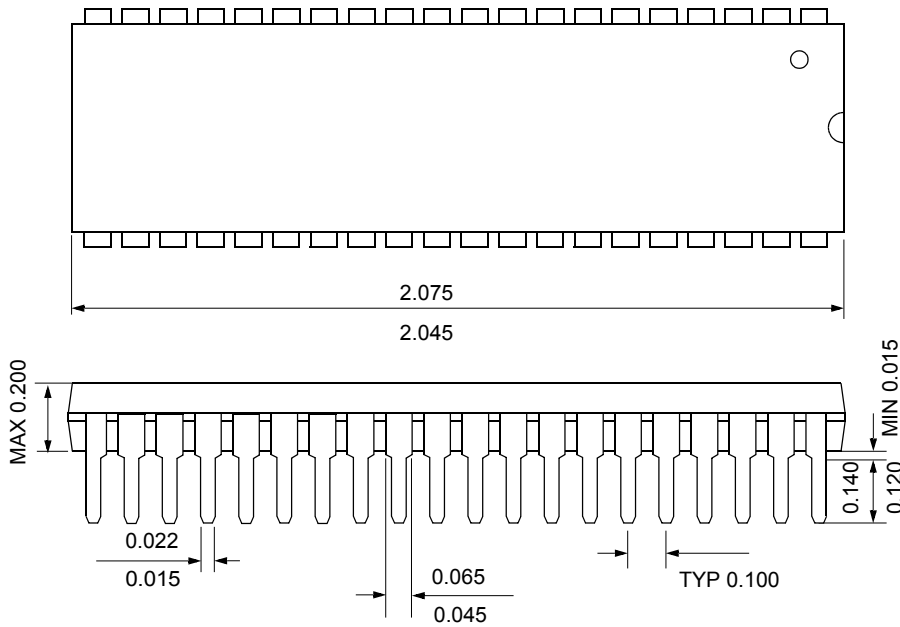

42 SDIP

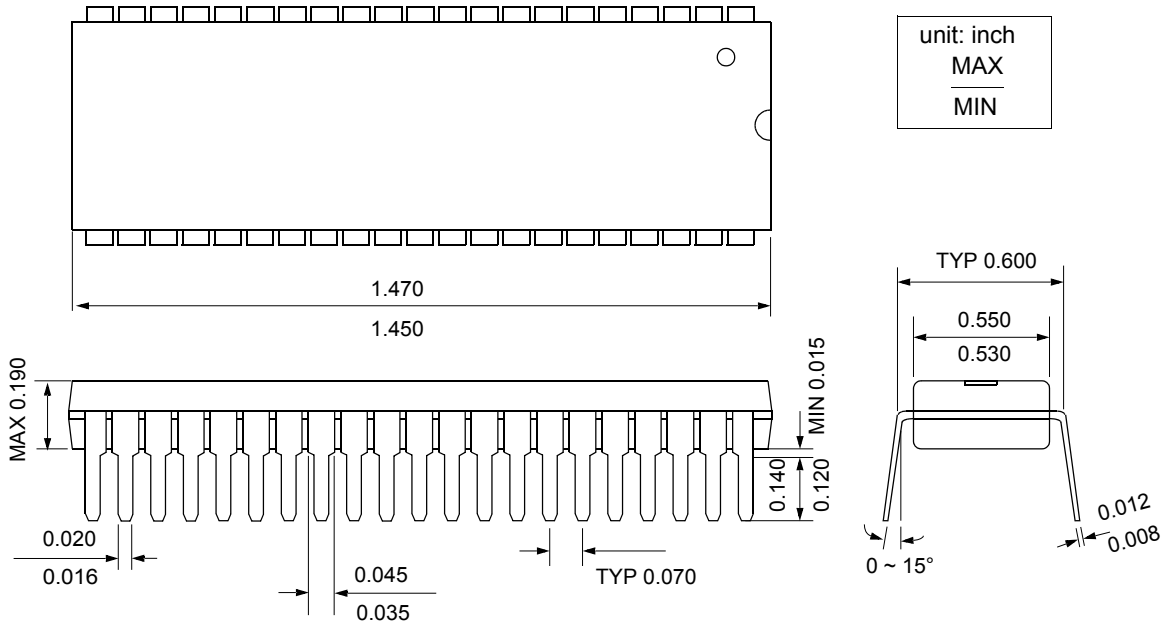

44 MQFP

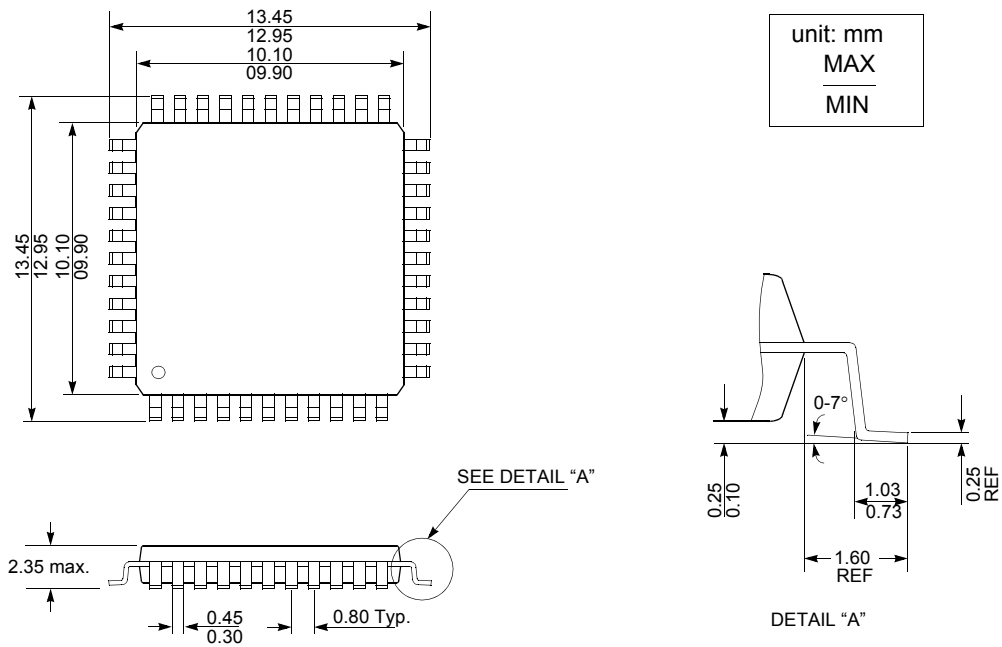

## 5. PIN FUNCTION

$V_{DD}$ : Supply voltage.

$V_{SS}$ : Circuit ground.

**RESET**: Reset the MCU.

$X_{IN}$ : Input to the inverting oscillator amplifier and input to the internal main clock operating circuit.

$X_{OUT}$ : Output from the inverting oscillator amplifier.

**RA0~RA7**: RA is an 8-bit, CMOS, bidirectional I/O port. RA pins can be used as outputs or inputs according to “1” or “0” written the their Port Direction Register(RAIO).

Port pin	Alternate function
RA0	EC0 ( Event Counter Input Source )
RA1	AN1 ( Analog Input Port 1 )
RA2	AN2 ( Analog Input Port 2 )
RA3	AN3 ( Analog Input Port 3 )
RA4	AN4 ( Analog Input Port 4 )
RA5	AN5 ( Analog Input Port 5 )
RA6	AN6 ( Analog Input Port 6 )
RA7	AN7 ( Analog Input Port 7 )

**Table 5-1 RA Port**

In addition, RA serves the functions of the various special features in Table 5-1 .

**RB0~RB7**: RB is an 8-bit, CMOS, bidirectional I/O port. RB pins can be used as outputs or inputs according to “1” or “0” written the their Port Direction Register (RBIO).

RB serves the functions of the various following special features in Table 5-2

Port pin	Alternate function
RB0	AN0 ( Analog Input Port 0 ) AVref ( External Analog Reference Pin )
RB1	BUZ ( Buzzer Driving Output Port )
RB2	INT0 ( External Interrupt Input Port 0 )
RB3	INT1 ( External Interrupt Input Port 1 )
RB4	PWM0 (PWM0 Output) COMP0 (Timer1 Compare Output)
RB5	PWM1 (PWM1 Output) COMP1 (Timer3 Compare Output)
RB6	EC1 (Event Counter Input Source)
RB7	TMR2OV (Timer2 Overflow Output)

**Table 5-2 RB Port**

PIN NAME	Pin No.	In/Out	Function
$V_{DD}$	43	-	Supply voltage
$V_{SS}$	34	-	Circuit ground

**Table 5-5 Pin Description**

**RC0~RC7**: RC is an 8-bit, CMOS, bidirectional I/O port. RC pins can be used as outputs or inputs according to “1” or “0” written the their Port Direction Register (RCIO).

RC serves the functions of the serial interface following special features in Table 5-3 .

Port pin	Alternate function
RC0	$\overline{SRDYIN}$ (SPI Ready Input) SRDYOUT (SPI Ready Output)
RC1	
RC2	
RC3	
RC4	SCKI (SPI CLK Input) SCKO (SPI CLK Output)
RC5	SIN (SPI Serial Data Input)
RC6	SOUT (SPI Serial Data Output)
RC7	

**Table 5-3 RC Port**

**RD0~RD7**: RD is an 8-bit, CMOS, bidirectional I/O port. RC pins can be used as outputs or inputs according to “1” or “0” written the their Port Direction Register (RDIO).

RD serves the functions of the external interrupt following special features in Table 5-4

Port pin	Alternate function
RD0	INT2 (External Interrupt Input Port 2) INT3 (External Interrupt Input Port 3)
RD1	
RD2	
RD3	
RD4	
RD5	
RD6	
RD7	

**Table 5-4 RD Port**

**RE0~RE6**: RE is a 7-bit, CMOS, bidirectional I/O port. RC pins can be used as outputs or inputs according to “1” or “0” written the their Port Direction Register (REIO).

PIN NAME	Pin No.	In/Out	Function	
RESET	33	I	Reset signal input	
X <sub>IN</sub>	31	I	Oscillation Input	
X <sub>OUT</sub>	32	O	Oscillation Output	
RA0 (EC0)	35	I/O (Input)	Normal I/O Ports	External Event Counter input 0
RA1 (AN1)	36			Analog Input Port 1
RA2 (AN2)	37			Analog Input Port 2
RA3 (AN3)	38			Analog Input Port 3
RA4 (AN4)	39			Analog Input Port 4
RA5 (AN5)	40			Analog Input Port 5
RA6 (AN6)	41			Analog Input Port 6
RA7 (AN7)	42			Analog Input Port 7
RB0 (AVref/AN0)	44	I/O (Input/Input)		Analog Reference / Analog Input Port 0
RB1 (BUZ)	1	I/O (Output)		Buzzer Driving Output
RB2 (INT0)	2	I/O (Input)		External Interrupt Input 0
RB3 (INT1)	3	I/O (Input)		External Interrupt Input 1
RB4 (PWM0/COMP0)	4	I/O (Output/Output)		PWM0 Output or Timer1 Compare Output
RB5 (PWM1/COMP1)	5	I/O (Output/Output)		PWM1 Output or Timer3 Compare Output
RB6 (EC1)	6	I/O (Input)		External Event Counter input 1
RB7 (TMR2OV)	7	I/O (Output)		Timer2 Overflow Output
RC0 ~ RC2	15 ~ 17	I/O		
RC3 (SRDYIN/SRDYOUT)	18	I/O (Input/Output)		SPI READY Input/Output
RC4 (SCK)	19	I/O (Input/Output)		SPI CLK Input/Output
RC5 (SIN)	20	I/O (Input)		SPI DATA Input
RC6 (SOUT)	21	I/O (Output)		SPI DATA Output
RC7	22	I/O		
RD0 (INT2)	23	I/O (Input)		External Interrupt Input 2
RD1 (INT3)	24	I/O (Input)		External Interrupt Input 3
RD2	25	I/O		
RD3 ~ RD7	26 ~ 30			
RE0 ~ RE6	14 ~ 8			

**Table 5-5 Pin Description**

## 6. PORT STRUCTURES

- **RESET**

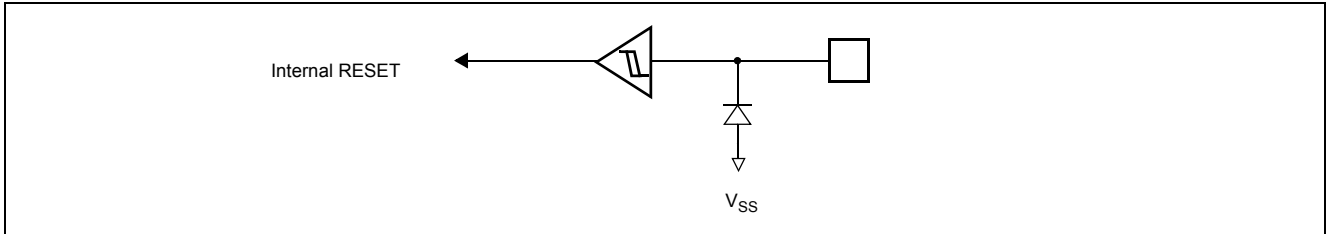

- **Xin, Xout (Crystal or Ceramic Resonator)**

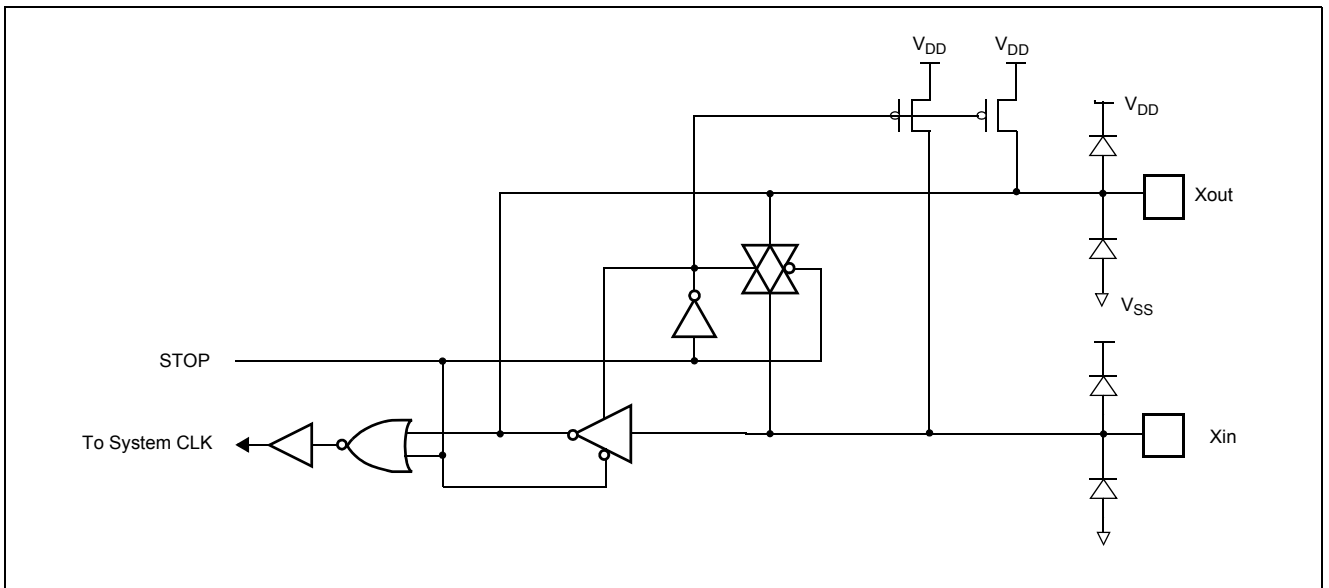

- **Xin, Xout (RC or R oscillation)**

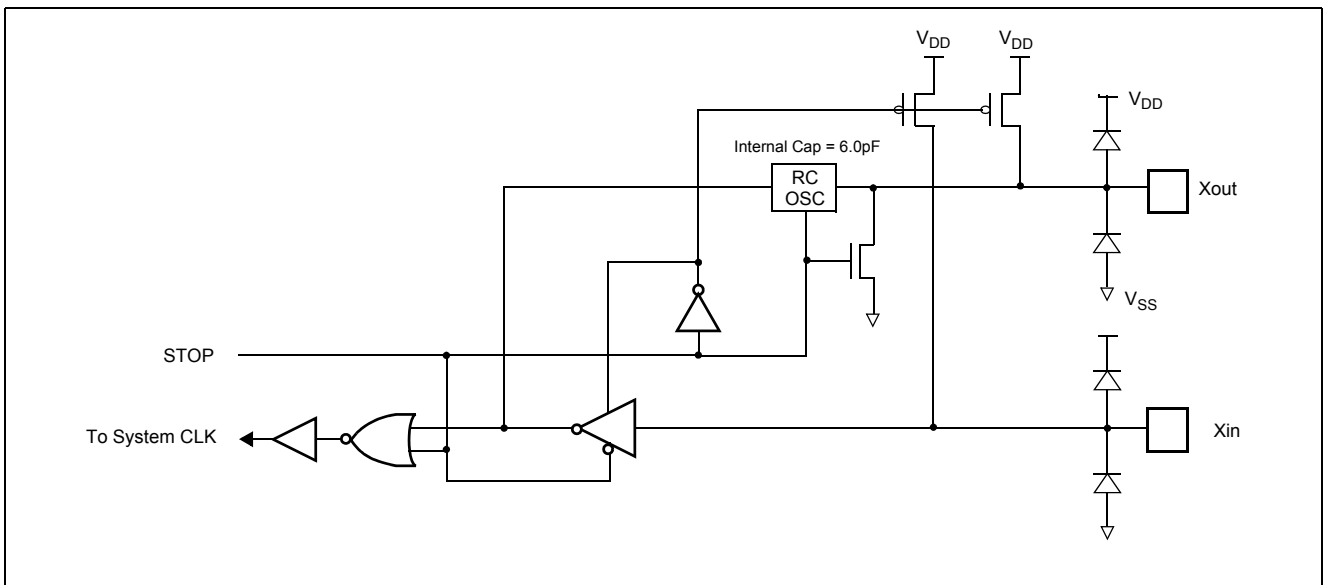



• RA0/EC0, RB6/EC1

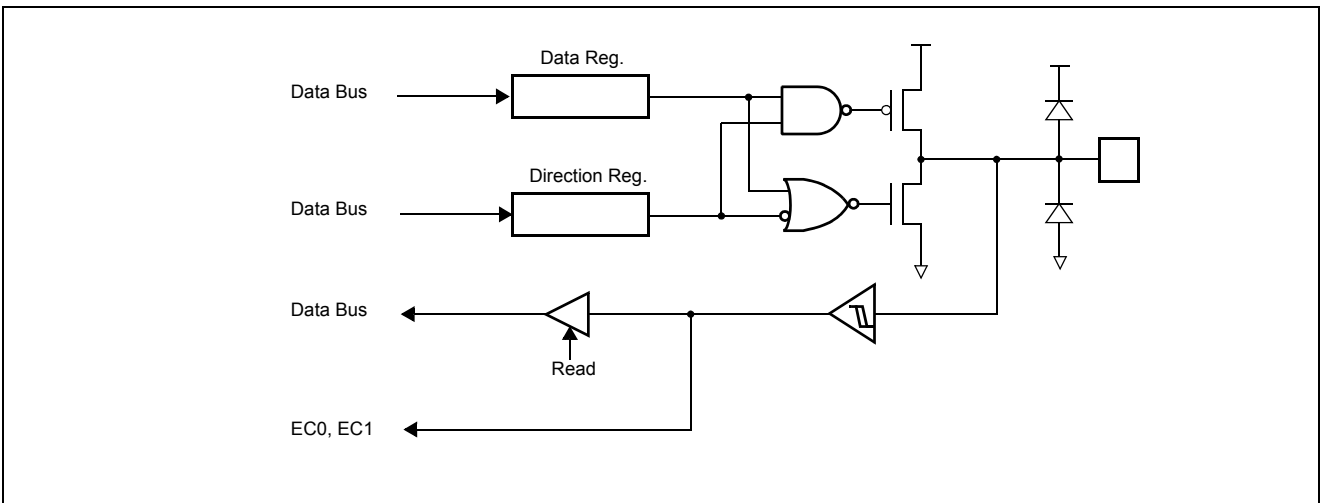

• RA1/AN1 ~ RA7/AN7

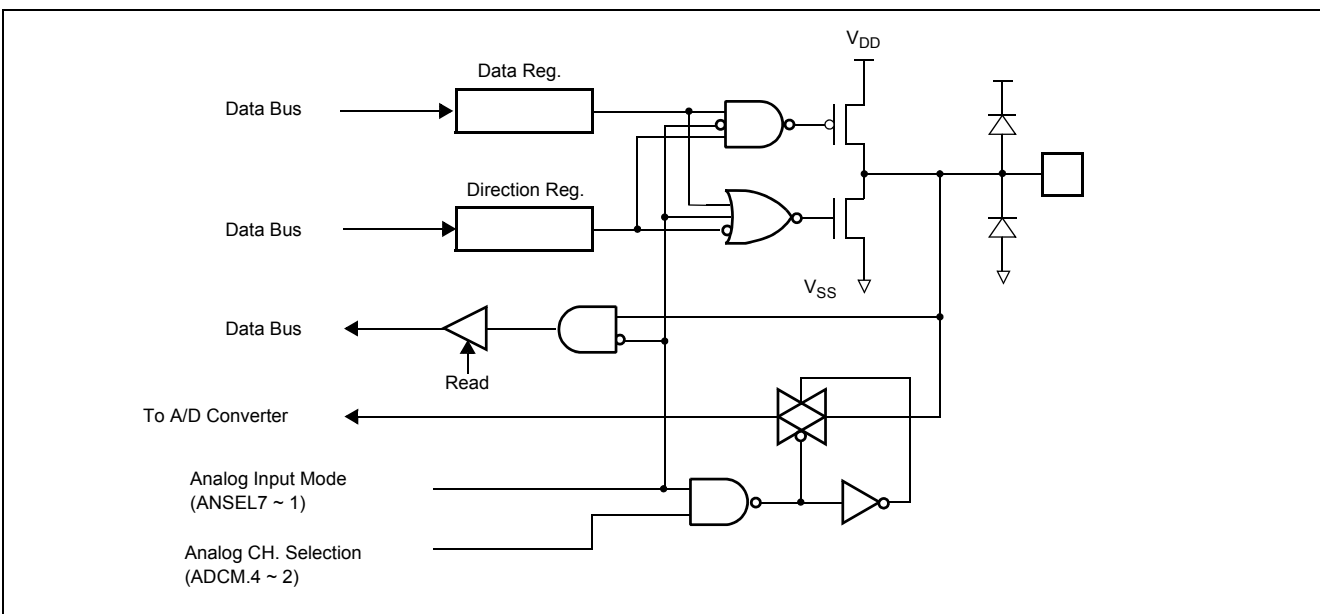

• RB1/BUZ, RB4/PWM0/COMP0, RB5/PWM1/

**COMP1, RB7/TMR2OV, RC6/SOUT**

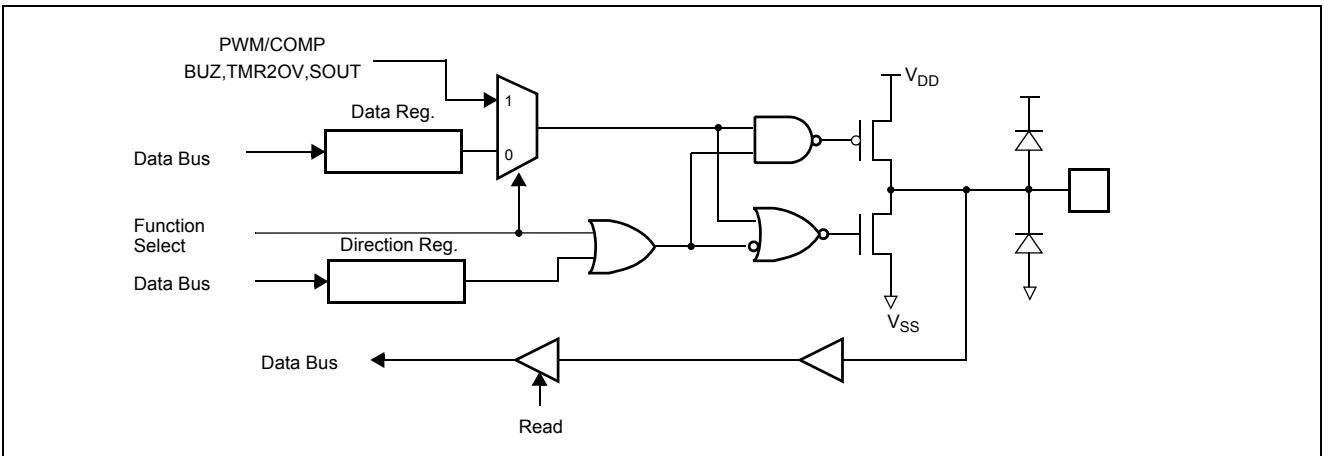

**• RB0 / AN0 / AVref**

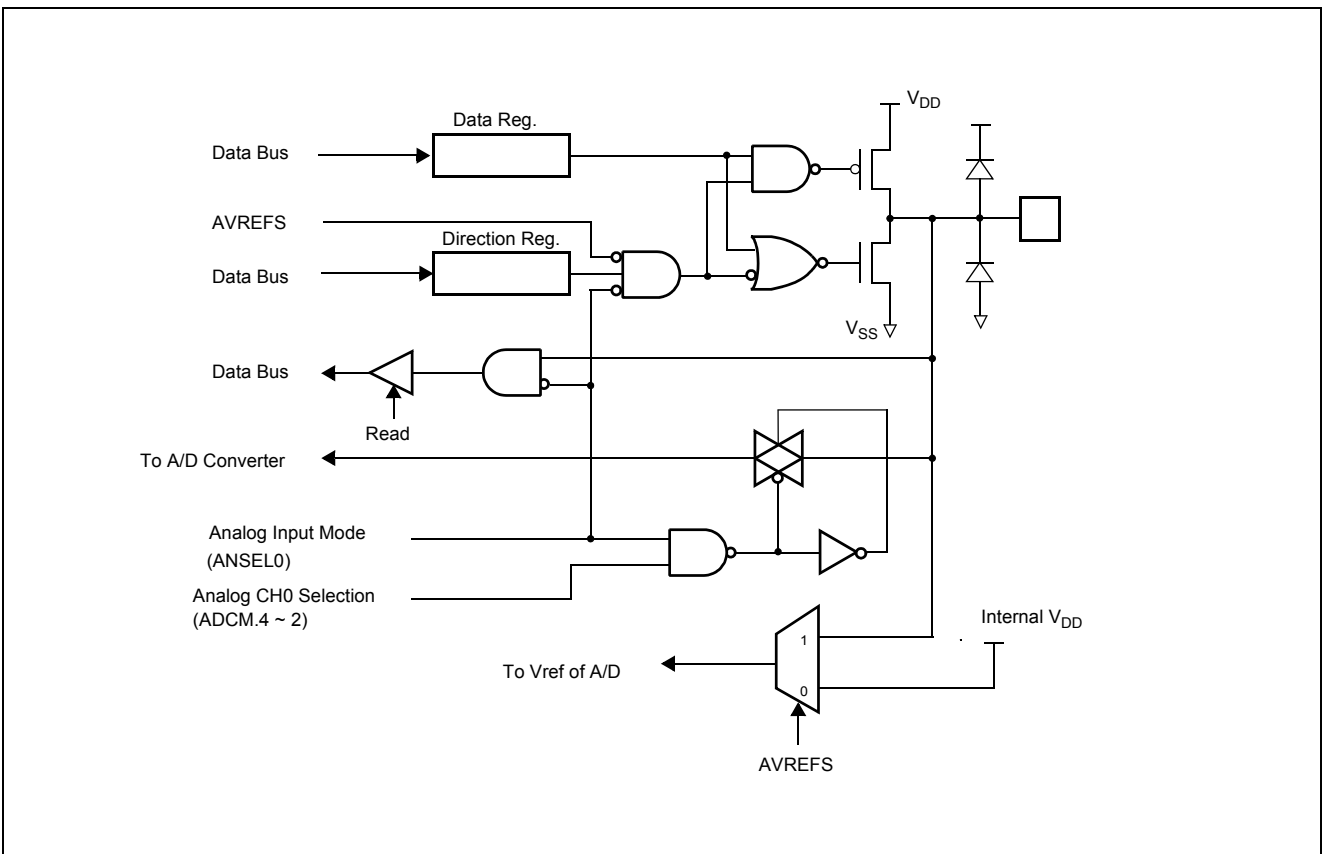

• RB2/INT0, RB3/INT1, RD0/INT2, RD1/INT3

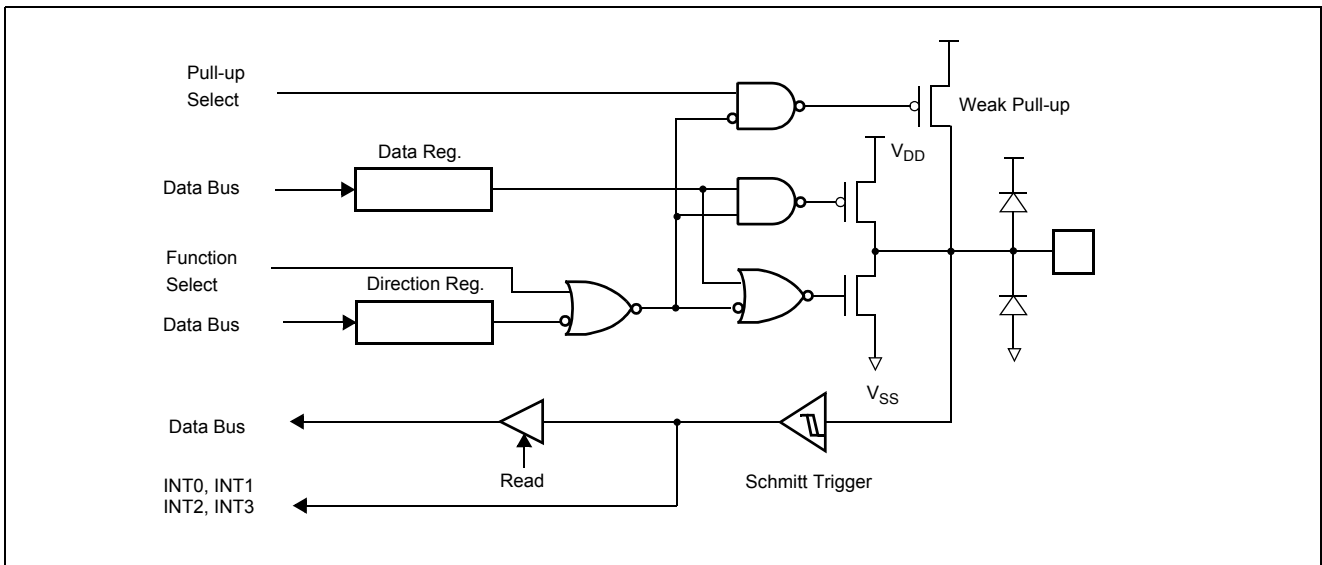

• RC5/SIN

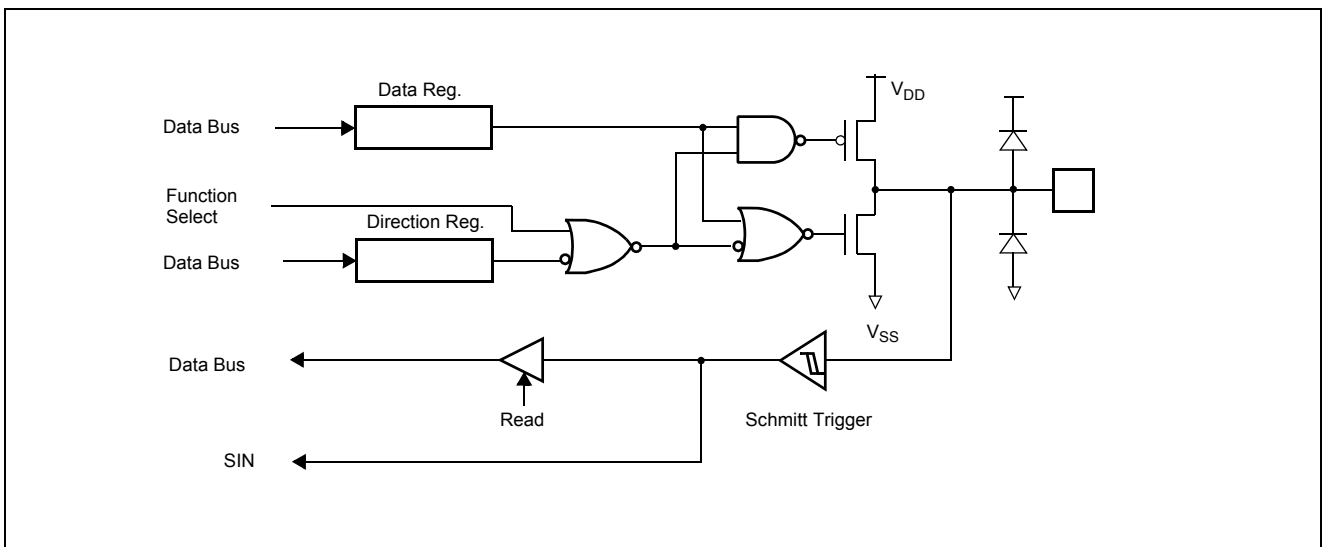

• RC0~2, RC7, RD2~7, RE0~6

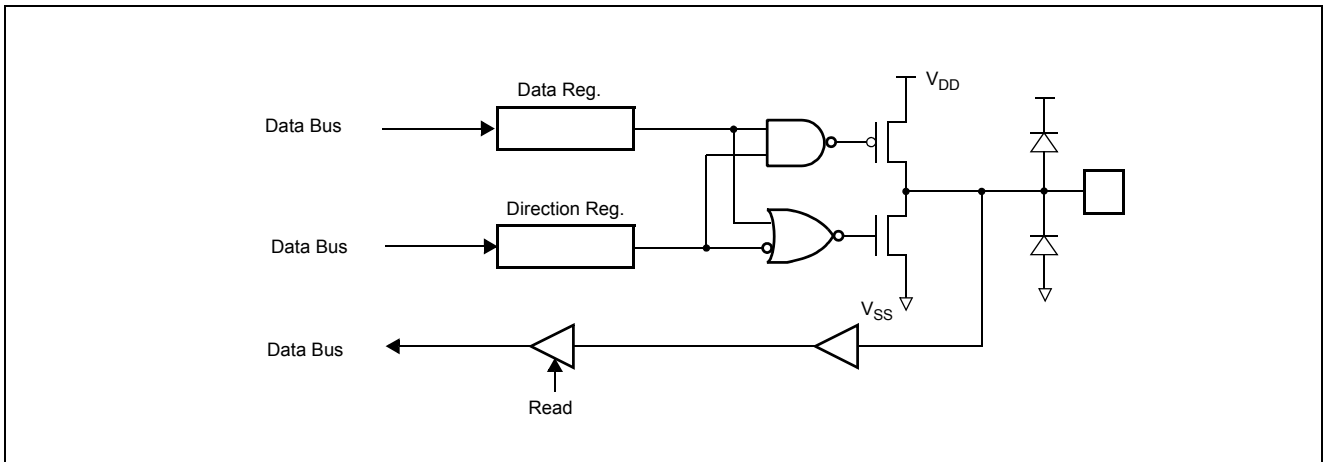

• RC3 / SRDYIN / SRDYOUT, RC4 / SCKIN / SCK- OUT

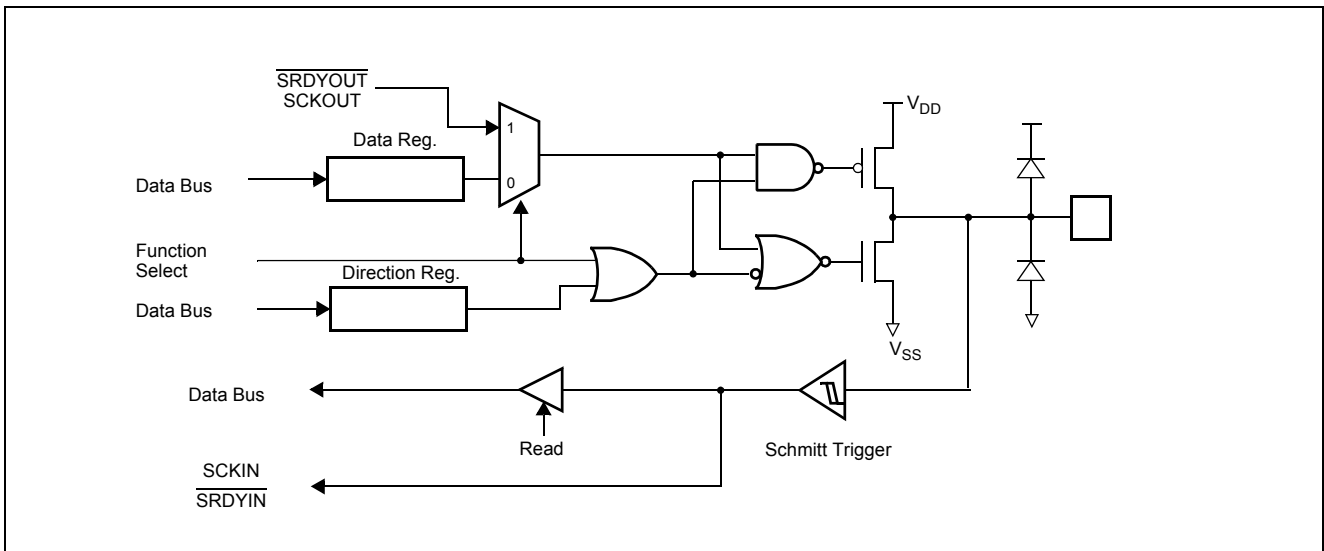

## 7. ELECTRICAL CHARACTERISTICS

### 7.1 Absolute Maximum Ratings

Supply voltage.....	-0.3 to +6.0 V
Storage Temperature .....	-40 to +125 °C
Voltage on any pin with respect to Ground ( $V_{SS}$ ) .....	-0.3 to $V_{DD}+0.3$
Maximum current out of $V_{SS}$ pin.....	200 mA
Maximum current into $V_{DD}$ pin.....	150 mA
Maximum current sunk by ( $I_{OL}$ per I/O Pin) .....	25 mA
Maximum output current sourced by ( $I_{OH}$ per I/O Pin) .....	15 mA
Maximum current ( $\Sigma I_{OL}$ ) .....	150 mA

Maximum current ( $\Sigma I_{OH}$ )..... 100 mA

**Note:** Stresses above those listed under “Absolute Maximum Ratings” may cause permanent damage to the device. This is a stress rating only and functional operation of the device at any other conditions above those indicated in the operational sections of this specification is not implied. Exposure to absolute maximum rating conditions for extended periods may affect device reliability.

### 7.2 Recommended Operating Conditions

Parameter	Symbol	Condition	Specifications		Unit
			Min.	Max.	
Supply Voltage	$V_{DD}$	$f_{XIN}=8\text{MHz}$	4.5	5.5	V
		$f_{XIN}=4.2\text{MHz}$	2.3	5.5	V
Operating Frequency	$f_{XIN}$	$V_{DD}=4.5\sim 5.5\text{V}$	1	8	MHz
		$V_{DD}=2.3\sim 5.5\text{V}$	1	4.2	MHz
Operating Temperature	$T_{OPR}$		-40	85	°C

### 7.3 A/D Converter Characteristics

( $T_A=25^\circ\text{C}$ ,  $V_{SS}=0\text{V}$ ,  $V_{DD}=5.12\text{V}$  @ $f_{XIN}=8\text{MHz}$ ,  $V_{DD}=3.072\text{V}$  @ $f_{XIN}=4\text{MHz}$ )

Parameter	Symbol	Condition	Specifications			Unit
			Min.	Typ.	Max.	
Analog Input Voltage Range	$V_{AIN}$	AVREFS=0	$V_{SS}$	-	$V_{DD}$	V
		AVREFS=1	$V_{SS}$	-	$V_{REF}$	
Analog Power Supply Input Voltage Range	$V_{REF}$	$V_{DD}=5\text{V}$	3	-	$V_{DD}$	V
		$V_{DD}=3\text{V}$	2.4	-	$V_{DD}$	V
Overall Accuracy	$N_{ACC}$		-	$\pm 0.7$	$\pm 1.5$	LSB
Non-Linearity Error	$N_{NLE}$		-	$\pm 0.8$	$\pm 1.5$	LSB
Differential Non-Linearity Error	$N_{DNLE}$		-	$\pm 1.0$	$\pm 1.5$	LSB
Zero Offset Error	$N_{ZOE}$		-	$\pm 1.0$	$\pm 1.5$	LSB
Full Scale Error	$N_{FSE}$		-	$\pm 0.25$	$\pm 0.5$	LSB
Gain Error	$N_{NLE}$		-	$\pm 1.0$	$\pm 1.5$	LSB
Conversion Time	$T_{CONV}$	$f_{XIN}=8\text{MHz}$	-	-	10	$\mu\text{S}$
		$f_{XIN}=4\text{MHz}$	-	-	20	
AVREF Input Current	$I_{REF}$	AVREFS=1	-	0.5	1.0	mA

## 7.4 DC Electrical Characteristics

( $T_A = -40 \sim 85^\circ\text{C}$ ,  $V_{DD} = 2.3 \sim 5.5\text{V}$ ,  $V_{SS} = 0\text{V}$ ),

Parameter	Symbol	Pin	Condition	Specifications			Unit
				Min.	Typ.	Max.	
Input High Voltage	$V_{IH1}$	$X_{IN}, \overline{\text{RESET}}$		$0.8 V_{DD}$	-	$V_{DD}$	V
	$V_{IH2}$	Hysteresis Input <sup>1</sup>		$0.8 V_{DD}$	-	$V_{DD}$	
	$V_{IH3}$	Normal Input		$0.7 V_{DD}$	-	$V_{DD}$	
Input Low Voltage	$V_{IL1}$	$X_{IN}, \overline{\text{RESET}}$		0	-	$0.2 V_{DD}$	V
	$V_{IL2}$	Hysteresis Input <sup>1</sup>		0	-	$0.2 V_{DD}$	
	$V_{IL3}$	Normal Input		0	-	$0.3 V_{DD}$	
Output High Voltage	$V_{OH}$	All Output Port	$V_{DD} = 5\text{V}$ , $I_{OH} = -5\text{mA}$	$V_{DD} - 1$	-	-	V
Output Low Voltage	$V_{OL}$	All Output Port	$V_{DD} = 5\text{V}$ , $I_{OL} = 10\text{mA}$	-	-	1	V
Input Pull-up Current	$I_P$	RB2, RB3, RD0, RD1	$V_{DD} = 5\text{V}$	-150	-	-70	$\mu\text{A}$
Input High Leakage Current	$I_{IH1}$	All Pins (except $X_{IN}$ )	$V_{DD} = 5\text{V}$	-	-	5	$\mu\text{A}$
	$I_{IH2}$	$X_{IN}$	$V_{DD} = 5\text{V}$	-	-	15	$\mu\text{A}$
Input Low Leakage Current	$I_{IL1}$	All Pins (except $X_{IN}$ )	$V_{DD} = 5\text{V}$	-5	-	-	$\mu\text{A}$
	$I_{IL2}$	$X_{IN}$	$V_{DD} = 5\text{V}$	-15	-	-	$\mu\text{A}$
Hysteresis	$ V_T $	Hysteresis Input <sup>1</sup>	$V_{DD} = 5\text{V}$	0.5	-	-	V
PFD Voltage	$V_{PFD}$	$V_{DD}$		2.1	-	3.1	V
Internal RC WDT Period	$T_{RCWDT}$	$X_{OUT}$	$V_{DD} = 5.5\text{V}$	30	-	100	$\mu\text{S}$
			$V_{DD} = 3.0\text{V}$	60	-	180	
Operating Current <sup>2</sup>	$I_{DD}$	$V_{DD}$	$V_{DD} = 5.5\text{V}$ , $f_{XIN} = 8\text{MHz}$	-	4	6.5	mA
			$V_{DD} = 3.0\text{V}$ , $f_{XIN} = 4\text{MHz}$	-	2	3	
Wake-up Timer Mode Current	$I_{WKUP}$	$V_{DD}$	$V_{DD} = 5.5\text{V}$ , $f_{XIN} = 8\text{MHz}$	-	1	2	mA
			$V_{DD} = 3.0\text{V}$ , $f_{XIN} = 4\text{MHz}$	-	0.3	1	
RCWDT Mode Current at STOP Mode	$I_{RCWDT}$	$V_{DD}$	$V_{DD} = 5.5\text{V}$	-	30	70	$\mu\text{A}$
			$V_{DD} = 3.0\text{V}$	-	5	50	
Stop Mode Current	$I_{STOP}$	$V_{DD}$	$V_{DD} = 5.5\text{V}$ , $f_{XIN} = 8\text{MHz}$	-	0.5	3	$\mu\text{A}$
			$V_{DD} = 3.0\text{V}$ , $f_{XIN} = 4\text{MHz}$	-	0.2	1	
INT Input Noise Cancel Time	$T_{INT\_NC}$	RB2, RB3, RD0, RD1	$V_{DD} = 5\text{V}$	0.2	-	0.5	$\mu\text{S}$
External RC Oscillator Frequency	$f_{RC\_OSC}$	$f_{XOUT} = f_{RC\_OSC} / 4$	$V_{DD} = 5.5\text{V}$ $R = 30\text{k}\Omega$ , $C = 10\text{pF}$	0.7	-	1.5	MHz
	$f_{R\_OSC}$	$f_{XOUT} = f_{R\_OSC} / 4$	$V_{DD} = 5.5\text{V}$ $R = 30\text{k}\Omega$	2	-	4	MHz

1. Hysteresis Input: RA0, RB2, RB3, RB6, RC3, RC4, RC5, RD0, RD1

2. This parameter is measured in internal EPROM operation at the all I/O port defined input mode.

**7.5 AC Characteristics**

( $T_A = -40 \sim +85^\circ\text{C}$ ,  $V_{DD} = 5\text{V} \pm 10\%$ ,  $V_{SS} = 0\text{V}$ )

Parameter	Symbol	Pins	Specifications			Unit
			Min.	Typ.	Max.	
Operating Frequency	$f_{CP}$	$X_{IN}$	1	-	8	MHz
External Clock Pulse Width	$t_{CPW}$	$X_{IN}$	50	-	-	nS
External Clock Transition Time	$t_{RCP}, t_{FCP}$	$X_{IN}$	-	-	20	nS
Oscillation Stabilizing Time	$t_{ST}$	$X_{IN}, X_{OUT}$	-	-	20	mS
External Input Pulse Width	$t_{EPW}$	INT0, INT1, INT2, INT3 EC0, EC1	2	-	-	$t_{sys}$
$\overline{\text{RESET}}$ Input Width	$t_{RST}$	$\overline{\text{RESET}}$	8	-	-	$t_{sys}$

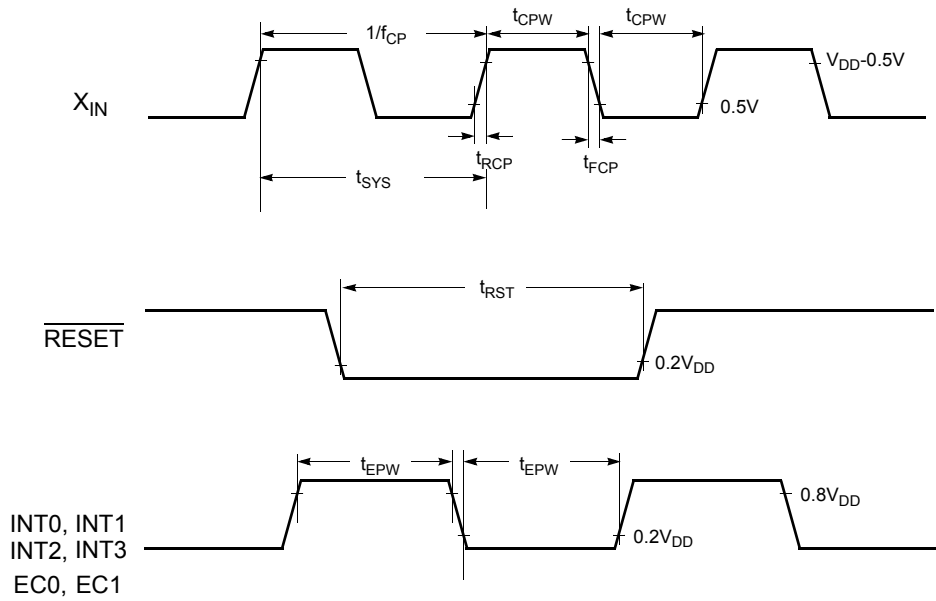

Figure 7-1 Timing Chart

### 7.6 Typical Characteristics

These graphs and tables provided in this section are for design guidance only and are not tested or guaranteed.

**In some graphs or tables the data presented are outside specified operating range (e.g. outside specified  $V_{DD}$  range). This is for information only and devices are guaranteed to operate properly only within the specified range.**

The data presented in this section is a statistical summary of data collected on units from different lots over a period of time. “Typical” represents the mean of the distribution while “max” or “min” represents (mean +  $3\sigma$ ) and (mean -  $3\sigma$ ) respectively where  $\sigma$  is standard deviation

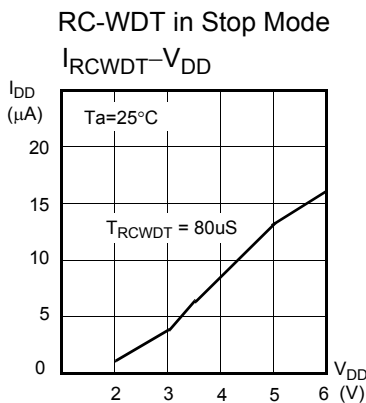
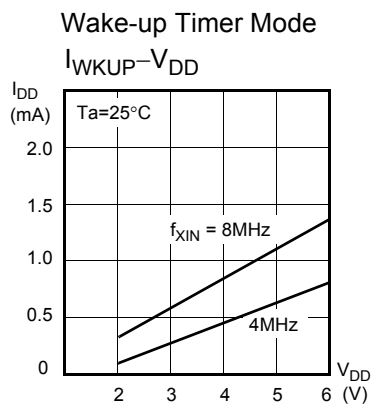
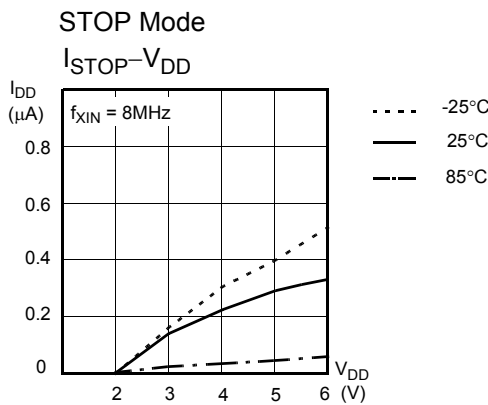
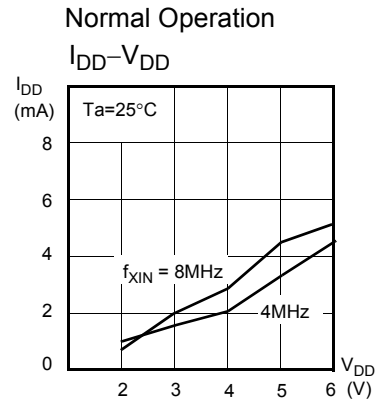
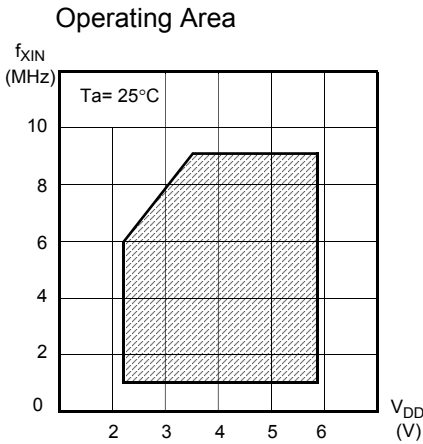



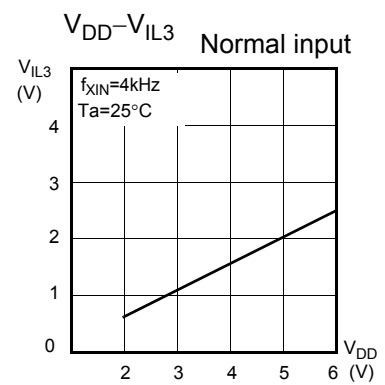
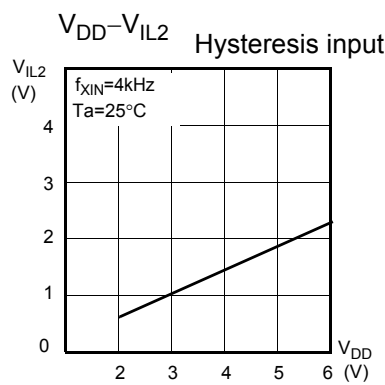
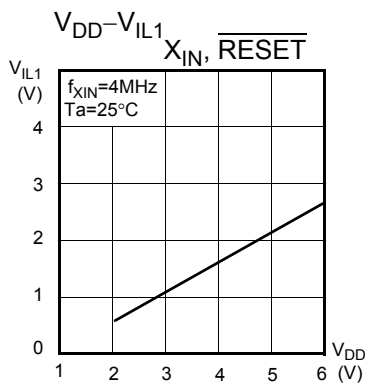
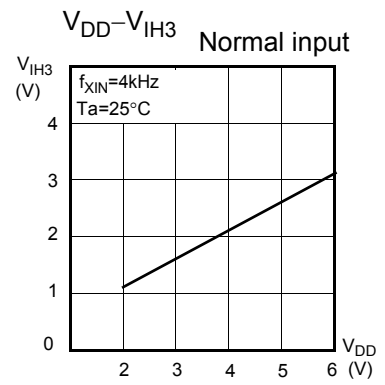
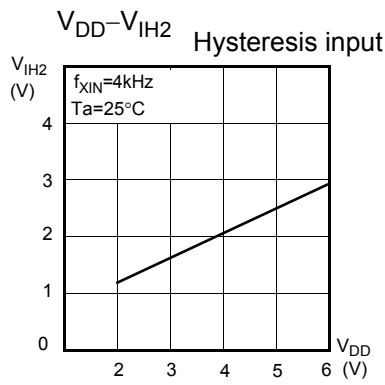
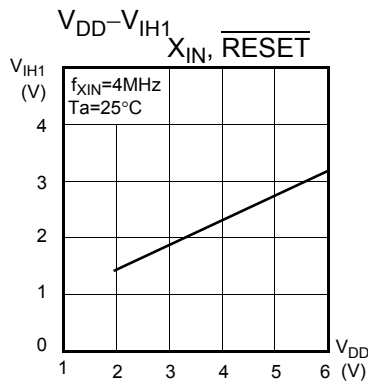
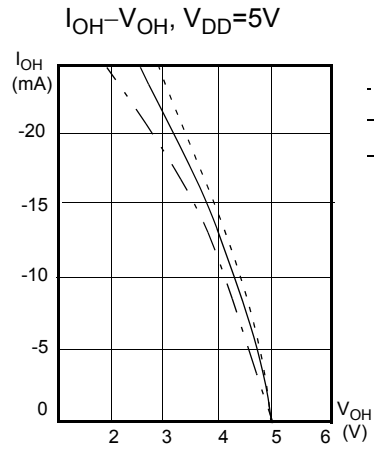
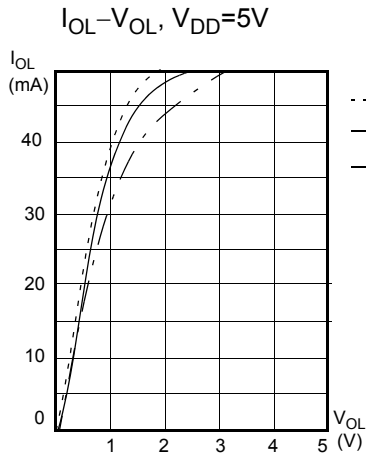

Typical RC Oscillator  
Frequency vs  $V_{DD}$

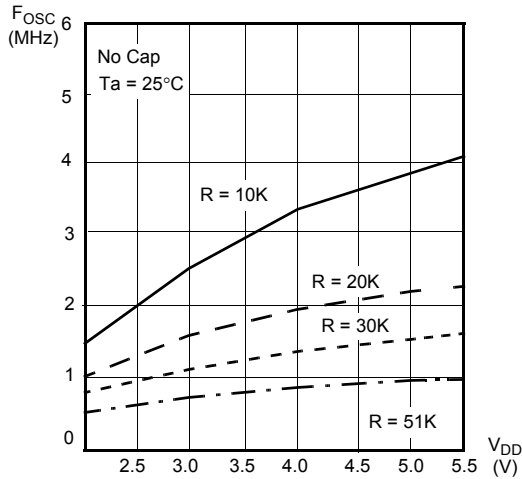

Typical RC Oscillator  
Frequency vs  $V_{DD}$

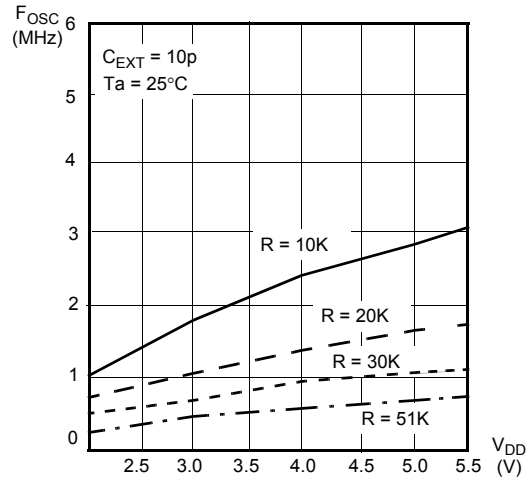

Typical RC Oscillator  
Frequency vs  $V_{DD}$

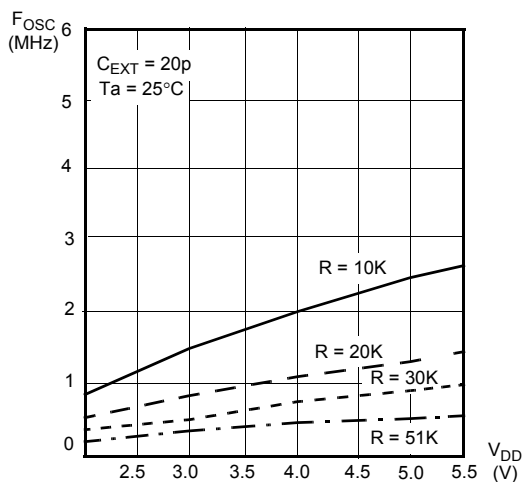

Typical RC Oscillator  
Frequency vs  $V_{DD}$

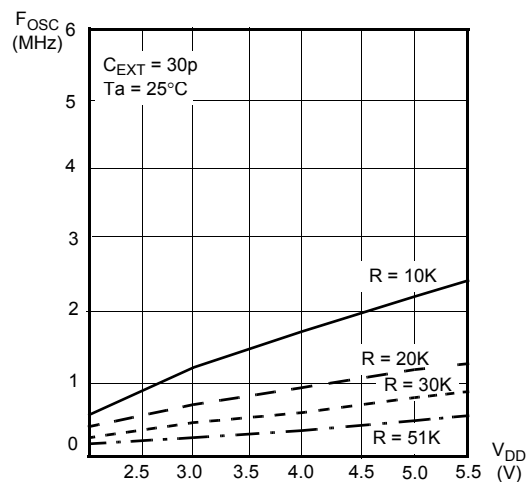

**Note:** The external RC oscillation frequencies shown in above are provided for design guidance only and not tested or guaranteed. The user needs to take into account that the external RC oscillation frequencies generated by the same circuit design may be not the same. Because there are variations in the resistance and capacitance due to the tolerance of external R and C components. The parasitic capacitance difference due to the different wiring length and layout may change the external RC oscillation frequencies.

**Note:** The external RC oscillation frequencies of the HMS87C1X04B/08B/16B may be different from that of the HMS81C1X04B/08B/16B. The user should modify the value of R and C components to get the proper frequency in exchanging OTP device to mask device.

## 8. MEMORY ORGANIZATION

The HMS87C1X04B/08B/16B has separate address spaces for Program memory and Data Memory. The Program memory can only be read, not written to. It can be up to 4K /8K /16K bytes of

Program memory. The Data memory can be read and written to up to 448 bytes including the stack area.

### 8.1 Registers

This device has six registers that are the Program Counter (PC), a Accumulator (A), two index registers (X, Y), the Stack Pointer (SP), and the Program Status Word (PSW). The Program Counter consists of 16-bit register.

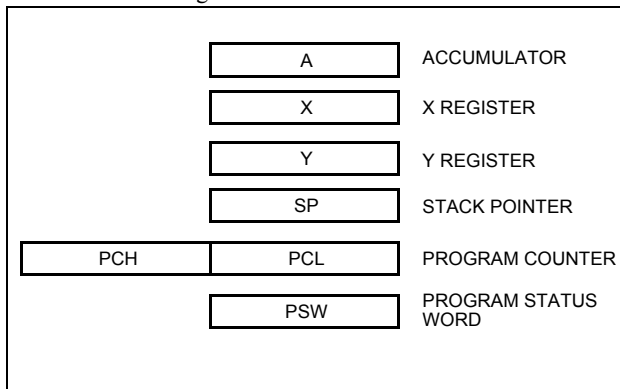

Figure 8-1 Configuration of Registers

**Accumulator:** The Accumulator is the 8-bit general purpose register, used for data operation such as transfer, temporary saving, and conditional judgement, etc.

The Accumulator can be used as a 16-bit register with Y Register as shown below.

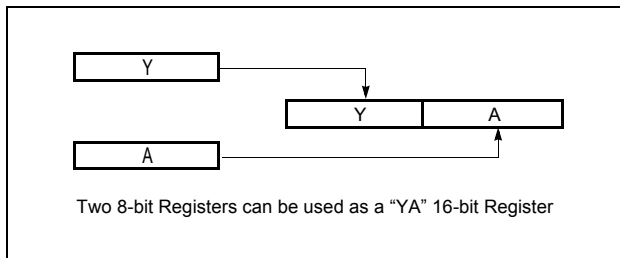

Figure 8-2 Configuration of YA 16-bit Register

**X, Y Registers:** In the addressing mode which uses these index registers, the register contents are added to the specified address, which becomes the actual address. These modes are extremely effective for referencing subroutine tables and memory tables. The index registers also have increment, decrement, comparison and data transfer functions, and they can be used as simple accumulators.

**Stack Pointer:** The Stack Pointer is an 8-bit register used for occurrence interrupts and calling out subroutines. Stack Pointer identifies the location in the stack to be accessed (save or restore).

Generally, SP is automatically updated when a subroutine call is executed or an interrupt is accepted. However, if it is used in excess of the stack area permitted by the data memory allocating configuration, the user-processed data may be lost.

The stack can be located at any position within 00<sub>H</sub> to BF<sub>H</sub> of the internal data memory. The SP is not initialized by hardware, requiring to write the initial value (the location with which the use of the stack starts) by using the initialization routine. Normally, the initial value of "BF<sub>H</sub>" is used.

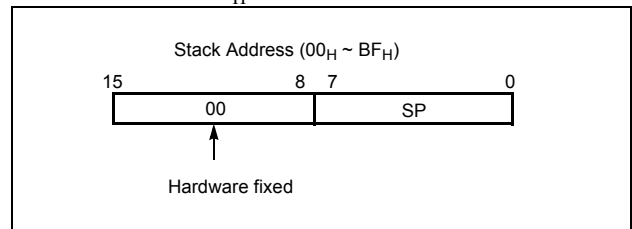

**Note:** The Stack Pointer must be initialized by software because its value is undefined after RESET.

Example: To initialize the SP

```
LDX    #0BFH
TXSP                      ; SP ← BFH
```

**Program Counter:** The Program Counter is a 16-bit wide which consists of two 8-bit registers, PCH and PCL. This counter indicates the address of the next instruction to be executed. In reset state, the program counter has reset routine address (PC<sub>H</sub>:0FF<sub>H</sub>, PC<sub>L</sub>:0FE<sub>H</sub>).

**Program Status Word:** The Program Status Word (PSW) contains several bits that reflect the current state of the CPU. The PSW is described in Figure 8-3 . It contains the Negative flag, the Overflow flag, Direct page select flag, the Break flag, the Half Carry (for BCD operation), the Interrupt enable flag, the Zero flag, and the Carry flag.

[Carry flag C]

This flag stores any carry or borrow from the ALU of CPU after an arithmetic operation and is also changed by the Shift Instruction or Rotate Instruction.

[Zero flag Z]

This flag is set when the result of an arithmetic operation or data transfer is "0" and is cleared by any other result.

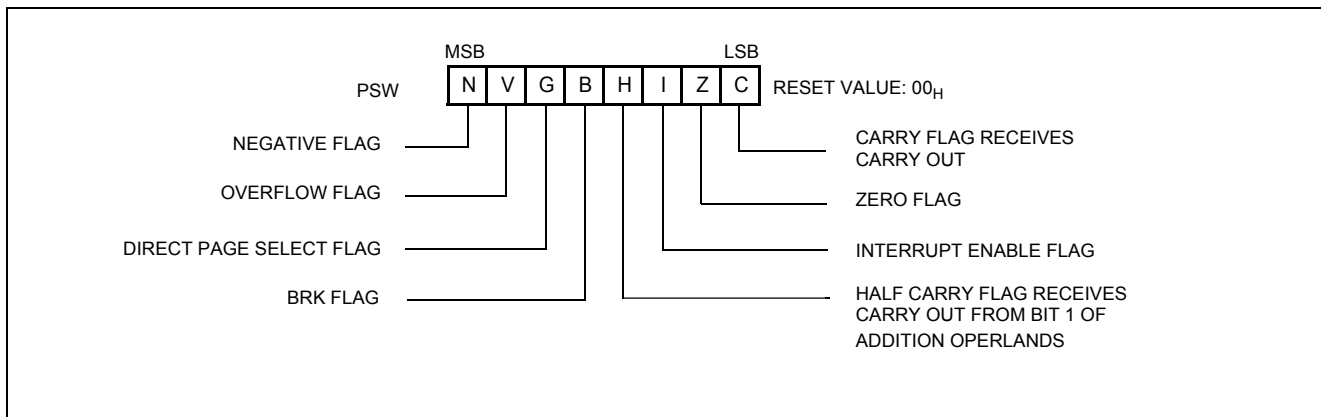

**Figure 8-3 PSW (Program Status Word) Register**

**[Interrupt disable flag I]**

This flag enables/disables all interrupts except interrupt caused by Reset or software BRK instruction. All interrupts are disabled when cleared to "0". This flag immediately becomes "0" when an interrupt is served. It is set by the EI instruction and cleared by the DI instruction.

**[Half carry flag H]**

After operation, this is set when there is a carry from bit 3 of ALU or there is no borrow from bit 4 of ALU. This bit can not be set or cleared except CLR<sub>V</sub> instruction with Overflow flag (V).

**[Break flag B]**

This flag is set by software BRK instruction to distinguish BRK from T<sub>CALL</sub> instruction with the same vector address.

**[Direct page select flag G]**

This flag assigned direct page for direct addressing mode. In the direct addressing mode, addressing area is within zero page 00<sub>H</sub> to FF<sub>H</sub> when this flag is "0". If it is set to "1", addressing area is 100<sub>H</sub> to 1FF<sub>H</sub>.

It is set by SET<sub>G</sub> instruction, and cleared by CLR<sub>G</sub> instruction.

**[Overflow flag V]**

This flag is set to "1" when an overflow occurs as the result of an arithmetic operation involving signs. An overflow occurs when the result of an addition or subtraction exceeds +127(7F<sub>H</sub>) or -128(80<sub>H</sub>). The CLR<sub>V</sub> instruction clears the overflow flag. There is no set instruction. When the BIT instruction is executed, bit 6 of memory is copied to this flag.

**[Negative flag N]**

This flag is set to match the sign bit (bit 7) status of the result of a data or arithmetic operation. When the BIT instruction is executed, bit 7 of memory is copied to this flag.

### 8.2 Program Memory

A 16-bit program counter is capable of addressing up to 64K bytes, but these devices have 4K/8K/16K bytes program memory space only physically implemented. Accessing a location above FFFF<sub>H</sub> will cause a wrap-around to 0000<sub>H</sub>.

Figure 8-4 , shows a map of Program Memory. After reset, the CPU begins execution from reset vector which is stored in address FFFE<sub>H</sub> and FFFF<sub>H</sub> as shown in Figure 8-5 .

As shown in Figure 8-4 , each area is assigned a fixed location in Program Memory. Program Memory area contains the user program.

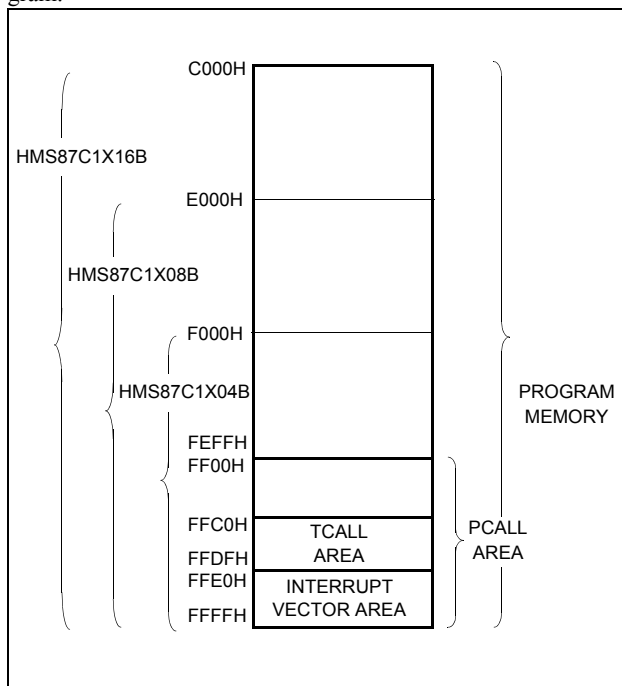

Figure 8-4 Program Memory Map

Page Call (PCALL) area contains subroutine program to reduce program byte length by using 2 bytes PCALL instead of 3 bytes CALL instruction. If it is frequently called, it is more useful to save program byte length.

Table Call (TCALL) causes the CPU to jump to each TCALL address, where it commences the execution of the service routine. The Table Call service area spaces 2-byte for every TCALL: 0FFC0<sub>H</sub> for TCALL15, 0FFC2<sub>H</sub> for TCALL14, etc., as shown in Figure 8-6 .

Example: Usage of TCALL

```

LDA    #5
      TCALL 0FH
      :
      :
;
;TABLE CALL ROUTINE
;
FUNC_A: LDA   LRG0
        RET
;
FUNC_B: LDA   LRG1
        RET
;
;TABLE CALL ADD. AREA
;
      ORG   0FFC0H
      DW   FUNC_A
      DW   FUNC_B
    
```

Annotations: A bracket on the right indicates that the first instruction (LDA #5) is 1 byte instead of 3 bytes. A bracket labeled ① points to the TCALL 0FH instruction, and a bracket labeled ② points to the DW FUNC\_A and DW FUNC\_B instructions, identifying the TCALL address area.

The interrupt causes the CPU to jump to specific location, where it commences the execution of the service routine. The External interrupt 0, for example, is assigned to location 0FFFA<sub>H</sub>. The interrupt service locations spaces 2-byte interval: 0FFF8<sub>H</sub> and 0FFF9<sub>H</sub> for External Interrupt 1, 0FFFA<sub>H</sub> and 0FFFB<sub>H</sub> for External Interrupt 0, etc.

As for the area from 0FF00<sub>H</sub> to 0FFFF<sub>H</sub>, if any area of them is not going to be used, its service location is available as general purpose Program Memory.

Address	Vector Area Memory
0FFE0 <sub>H</sub>	-
E2	-
E4	Serial Peripheral Interface Interrupt Vector Area
E6	Basic Interval Interrupt Vector Area
E8	Watchdog Timer Interrupt Vector Area
EA	A/D Converter Interrupt Vector Area
EC	Timer/Counter 3 Interrupt Vector Area
EE	Timer/Counter 2 Interrupt Vector Area
F0	External Interrupt 3 Vector Area
F2	External Interrupt 2 Vector Area
F4	Timer/Counter 1 Interrupt Vector Area
F6	Timer/Counter 0 Interrupt Vector Area
F8	External Interrupt 1 Vector Area
FA	External Interrupt 0 Vector Area
FC	-
FE	RESET Vector Area

NOTE:  
“-” means reserved area.

Figure 8-5 Interrupt Vector Area

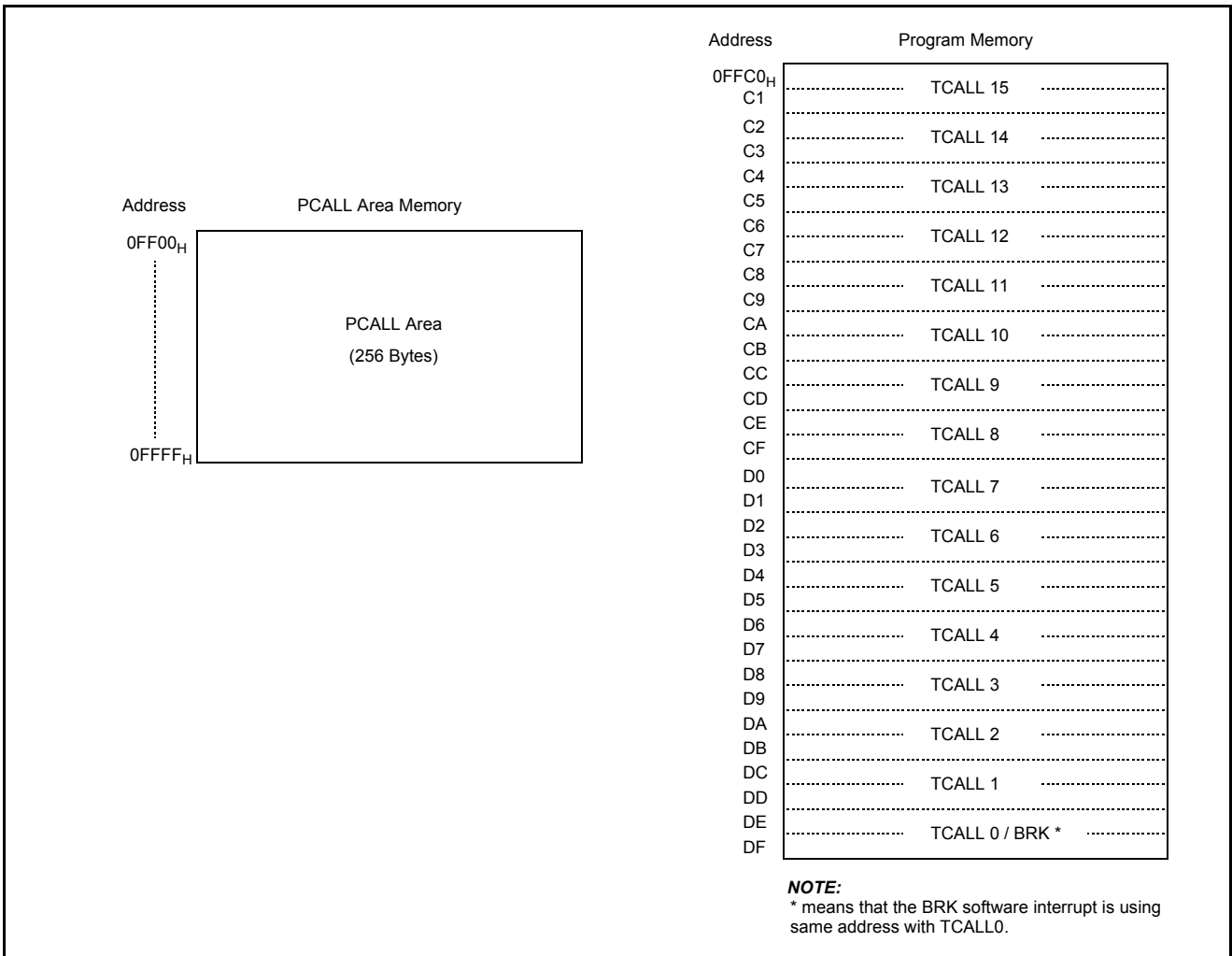
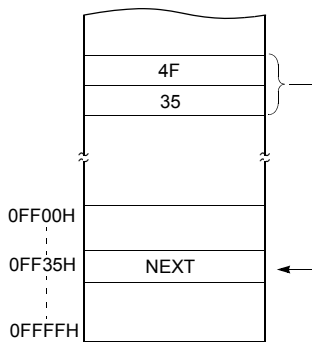

Figure 8-6 PCALL and TCALL Memory Area

**PCALL → rel**

4F35 PCALL 35H



**TCALL → n**

4A TCALL 4

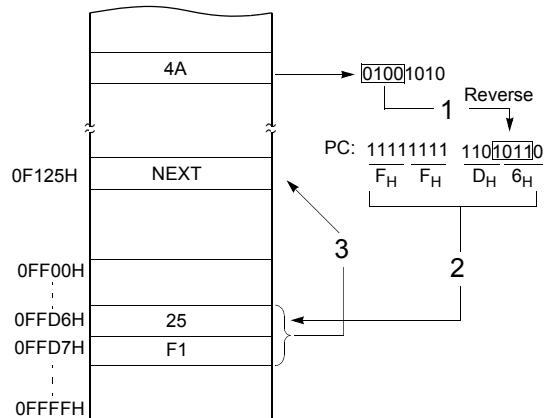

Example: The usage software example of Vector address and the initialize part.

```

ORG    0FFE0H

DW     NOT_USED; (0FFE0)
DW     NOT_USED; (0FFE2)
DW     SPI_INT; (0FFE4) Serial Peripheral Interface
DW     BIT_INT; (0FFE6) Basic Interval Timer
DW     WDT_INT; (0FFE8) Watchdog Timer
DW     AD_INT; (0FFEA) A/D
DW     TMR3_INT; (0FFEC) Timer-3
DW     TMR2_INT; (0FFEE) Timer-2
DW     INT3; (0FFF0) Int.3
DW     INT2; (0FFF2) Int.2
DW     TMR1_INT; (0FFF4) Timer-1
DW     TMR0_INT; (0FFF6) Timer-0
DW     INT1; (0FFF8) Int.1
DW     INT0; (0FFFA) Int.0
DW     NOT_USED; (0FFFC)
DW     RESET; (0FFFE) Reset

ORG    0F000H

;*****
;          MAIN      PROGRAM      *
;*****
;
RESET:  DI          ;Disable All Interrupts
        LDX        #0
RAM_CLR: LDA        #0;RAM Clear(!0000H->!00BFH)
        STA        {X}+;0-page Clear
        CMPX       #0C0H
        BNE        RAM_CLR

        SETG
        LDX        #0
RAM_CL1: LDA        #0;RAM Clear(!0100H->!01FFH)
        STA        {X}+;1-page Clear
        CMPX       #0
        BNE        RAM_CL1
        CLRG

;
        LDX        #0BFH;Stack Pointer Initialize
        TXSP

;
        CALL       INITIAL;

;
        LDM        RA, #0;Normal Port A
        LDM        RAIO,#1000_0010B;Normal Port Direction
        LDM        RB, #0;Normal Port B
        LDM        RBIO,#1000_0010B;Normal Port Direction
        :
        :
        LDM        PFDR,#0;Enable Power Fail Detector
        :

```

### 8.3 Data Memory

Figure 8-7 shows the internal Data Memory space available. Data Memory is divided into two groups, a user RAM (including Stack) and control registers.

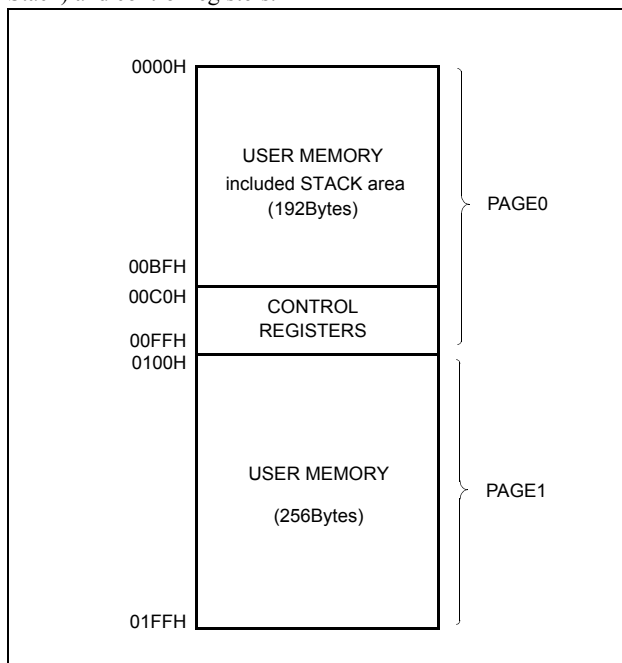

Figure 8-7 Data Memory Map

#### User Memory

The HMS87C1X04B/08B/16B have  $448 \times 8$  bits for the user memory (RAM).

#### Control Registers

The control registers are used by the CPU and Peripheral function blocks for controlling the desired operation of the device. Therefore these registers contain control and status bits for the interrupt system, the timer/ counters, analog to digital converters and I/O ports. The control registers are in address range of  $0C0_H$  to  $0FF_H$ .

Note that unoccupied addresses may not be implemented on the chip. Read accesses to these addresses will in general return random data, and write accesses will have an indeterminate effect.

More detailed informations of each register are explained in each peripheral section.

**Note:** Write only registers can not be accessed by bit manipulation instruction. Do not use read-modify-write instruction. Use byte manipulation instruction.

Example; To write at CKCTLR

```
LDM CKCTLR, #09H ;Divide ratio ÷16
```

Address	Symbol	R/W	RESET Value	Addressing mode
0C0H	RA	R/W	Undefined	byte, bit <sup>1</sup>
0C1H	RAIO	W	0000_0000	byte <sup>2</sup>
0C2H	RB	R/W	Undefined	byte, bit
0C3H	RBIO	W	0000_0000	byte
0C4H	RC	R/W	Undefined	byte, bit
0C5H	RCIO	W	0000_0000	byte
0C6H	RD	R/W	Undefined	byte, bit
0C7H	RDIO	W	0000_0000	byte
0C8H	RE	R/W	Undefined	byte, bit
0C9H	REIO	W	-000_0000	byte
0CAH	RAFUNC	W	0000_0000	byte
0CBH	RBFUNC	W	0000_0000	byte
0CCH	PUPSEL	W	----_0000	byte
0CDH	RDFUNC	W	----_--00	byte
0D0H	TM0	R/W	--00_0000	byte, bit
0D1H	T0	R	0000_0000	byte
0D1H	TDR0	W	1111_1111	byte
0D1H	CDR0	R	0000_0000	byte
0D2H	TM1	R/W	0000_0000	byte, bit
0D3H	TDR1	W	1111_1111	byte
0D3H	T1PPR	W	1111_1111	byte
0D4H	T1	R	0000_0000	byte
0D4H	CDR1	R	0000_0000	byte
0D4H	T1PDR	R/W	0000_0000	byte
0D5H	PWM0HR	W	----_0000	byte
0D6H	TM2	R/W	--00_0000	byte, bit
0D7H	T2	R	0000_0000	byte
0D7H	TDR2	W	1111_1111	byte
0D7H	CDR2	R	0000_0000	byte
0D8H	TM3	R/W	0000_0000	byte, bit
0D9H	TDR3	W	1111_1111	byte
0D9H	T3PPR	W	1111_1111	byte
0DAH	T3	R	0000_0000	byte
0DAH	CDR3	R	0000_0000	byte
0DAH	T3PDR	R/W	0000_0000	byte
0DBH	PWM1HR	W	----_0000	byte
0DEH	BUR	W	1111_1111	byte
0E0H	SIOM	R/W	0000_0001	byte, bit
0E1H	SIOR	R/W	Undefined	byte, bit

Table 8-1 Control Registers



0E2H	IENH	R/W	0000_0000	byte, bit
0E3H	IENL	R/W	0000_----	byte, bit
0E4H	IRQH	R/W	0000_0000	byte, bit
0E5H	IRQL	R/W	0000_----	byte, bit
0E6H	IEDS	R/W	0000_0000	byte, bit
0EAH	ADCM	R/W	--00_0001	byte, bit
0EBH	ADCR	R	Undefined	byte
0ECH	BITR	R	0000_0000	byte
0ECH	CKCTRL	W	-001_0111	byte
0EDH	WDTR	R	0000_0000	byte
0EDH	WDTR	W	0111_1111	byte
0EFH	PFDR	R/W	----_0100	byte, bit

**Table 8-1 Control Registers**

1. "byte, bit" means that register can be addressed by not only bit but byte manipulation instruction.
2. "byte" means that register can be addressed by only byte manipulation instruction. On the other hand, do not use any read-modify-write instruction such as bit manipulation for clearing bit.

**Note:** Several names are given at same address. Refer to

below table.

Addr.	When read			When write	
	Timer Mode	Capture Mode	PWM Mode	Timer Mode	PWM Mode
D1H	T0	CDR0	-	TDR0	-
D3H	-			TDR1	T1PPR
D4H	T1	CDR1	T1PDR	-	T1PDR
D7H	T2	CDR2	-	TDR2	-
D9H	-			TDR3	T3PPR
DAH	T3	CDR3	T3PDR	-	T3PDR
ECH	BITR			CKCTRL	

**Table 8-2 Various Register Name in Same Address**

**Stack Area**

The stack provides the area where the return address is saved before a jump is performed during the processing routine at the execution of a subroutine call instruction or the acceptance of an interrupt.

When returning from the processing routine, executing the subroutine return instruction [RET] restores the contents of the program counter from the stack; executing the interrupt return instruction [RETI] restores the contents of the program counter and flags.

The save/restore locations in the stack are determined by the stack pointed (SP). The SP is automatically decreased after the saving, and increased before the restoring. This means the value of the SP indicates the stack location number for the next save.

Address	Name	Bit 7	Bit 6	Bit 5	Bit 4	Bit 3	Bit 2	Bit 1	Bit 0
C0H	RA	RA Port Data Register							
C1H	RAIO	RA Port Direction Register							
C2H	RB	RB Port Data Register							
C3H	RBIO	RB Port Direction Register							
C4H	RC	RC Port Data Register							
C5H	RCIO	RC Port Direction Register							
C6H	RD	RD Port Data Register							
C7H	RDIO	RD Port Direction Register							
C8H	RE	RE Port Data Register							
C9H	REIO	RE Port Direction Register							
CAH	RAFUNC	ANSEL7	ANSEL6	ANSEL5	ANSEL4	ANSEL3	ANSEL2	ANSEL1	ANSEL0
CBH	RBFUNC	TMR2OV	EC1I	PWM1O	PWM0O	INT1I	INT0I	BUZO	AVREFS
CCH	PUPSEL	-	-	-	-	PUPSEL3	PUPSEL2	PUPSEL1	PUPSEL0
CDH	RDFUNC	-	-	-	-	-	-	INT3I	INT2I
D0H	TM0	-	-	CAP0	T0CK2	T0CK1	T0CK0	T0CN	T0ST
D1H	T0/TDR0/ CDR0	Timer0 Register / Timer0 Data Register / Capture0 Data Register							
D2H	TM1	POL	16BIT	PWM0E	CAP1	T1CK1	T1CK0	T1CN	T1ST
D3H	TDR1/ T1PPR	Timer1 Data Register / PWM0 Period Register							
D4H	T1/CDR1/ T1PDR	Timer1 Register / Capture1 Data Register / PWM0 Duty Register							
D5H	PWM0HR	PWM0 High Register							
D6H	TM2	-	-	CAP2	T2CK2	T2CK1	T2CK0	T2CN	T2ST
D7H	T2/TDR2/ CDR2	Timer2 Register / Timer2 Data Register / Capture2 Data Register							
D8H	TM3	POL	16BIT	PWM1E	CAP3	T3CK1	T3CK0	T3CN	T3ST
D9H	TDR3/ T3PPR	Timer3 Data Register / PWM1 Period Register							
DAH	T3/CDR3/ T3PDR	Timer3 Register / Capture3 Data Register / PWM1Duty Register							
DBH	PWM1HR	PWM1 High Register							
DEH	BUR	BUCK1	BUCK0	BUR5	BUR4	BUR3	BUR2	BUR1	BUR0
E0H	SIOM	POL	SRDY	SM1	SM0	SCK1	SCK0	SIOST	SIOSF
E1H	SIOR	SPI DATA REGISTER							
E2H	IENH	INT0E	INT1E	T0E	T1E	INT2E	INT3E	T2E	T3E
E3H	IENL	ADE	WDTE	BITE	SPIE	-	-	-	-
E4H	IRQH	INT0IF	INT1IF	T0IF	T1IF	INT2IF	INT3IF	T2IF	T3IF

**Table 8-3 Control Registers of HMS87C1X04B/08B/16B**

*These registers of shaded area can not be accessed by bit manipulation instruction as "SET1, CLR1", but should be accessed by register operation instruction as "LDM dp, #imm".*

E5H	IRQL	ADIF	WDTIF	BITIF	SPIF	-	-	-	-
E6H	IEDS	IED3H	IED3L	IED2H	IED2L	IED1H	IED1L	IED0H	IED0L
EAH	ADCM	-	-	ADEN	ADS2	ADS1	ADS0	ADST	ADSF
EBH	ADCR	ADC Result Data Register							
ECH	BITR <sup>1</sup>	Basic Interval Timer Data Register							
ECH	CKCTLR <sup>1</sup>	-	WAKEUP	RCWDT	WDTON	BTCL	BTS2	BTS1	BTS0
EDH	WDTR	WDTCL	7-bit Watchdog Counter Register						
EFH	PFDR <sup>2</sup>	-	-	-	-	PFDOPR	PFDIS	PFDM	PFDS

**Table 8-3 Control Registers of HMS87C1X04B/08B/16B**

*These registers of shaded area can not be accessed by bit manipulation instruction as "SET1, CLR1", but should be accessed by register operation instruction as "LDM dp, #imm".*

- 1. The register BITR and CKCTLR are located at same address. Address ECH is read as BITR, written to CKCTLR.*
- 2. The register PFDR only be implemented on devices, not on In-circuit Emulator.*

### 8.4 Addressing Mode

The HMS87C1X04B/08B/16B uses six addressing modes;

- Register addressing
- Immediate addressing
- Direct page addressing
- Absolute addressing
- Indexed addressing
- Register-indirect addressing

#### (1) Register Addressing

Register addressing accesses the A, X, Y, C and PSW.

#### (2) Immediate Addressing → #imm

In this mode, second byte (operand) is accessed as a data immediately.

Example:

```
0435   ADC   #35H
```

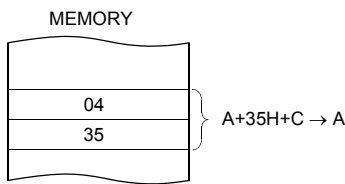

```
E45535  LDM   35H, #55H
```

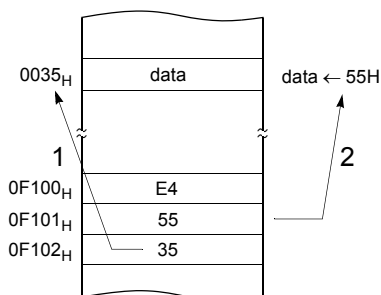

#### (3) Direct Page Addressing → dp

In this mode, a address is specified within direct page.

Example;

```
C535   LDA   35H           ;A ←RAM[35H]
```

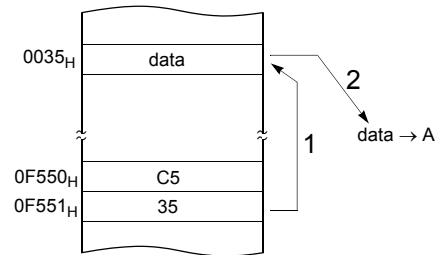

#### (4) Absolute Addressing → !abs

Absolute addressing sets corresponding memory data to Data, i.e. second byte(Operand I) of command becomes lower level address and third byte (Operand II) becomes upper level address. With 3 bytes command, it is possible to access to whole memory area.

ADC, AND, CMP, CMPX, CMPY, EOR, LDA, LDX, LDY, OR, SBC, STA, STX, STY

Example;

```
0735F0  ADC   !0F035H     ;A ←ROM[0F035H]
```

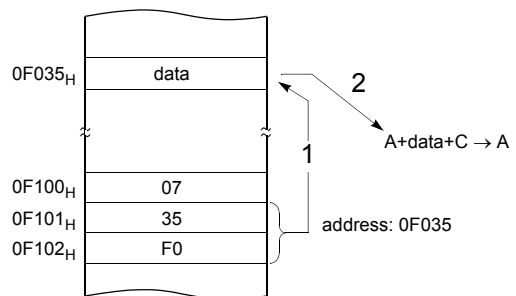

The operation within data memory (RAM)  
ASL, BIT, DEC, INC, LSR, ROL, ROR

Example; Addressing accesses the address 0035<sub>H</sub>.

```
983500 INC !0035H ; A ←RAM[035H]
```

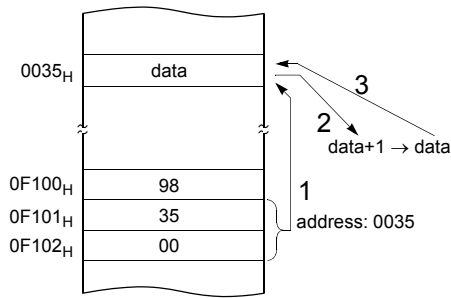

**X indexed direct page, auto increment → {X}+**

In this mode, a address is specified within direct page by the X register and the content of X is increased by 1.

LDA, STA

Example; X=35<sub>H</sub>

```
DB LDA {X}+
```

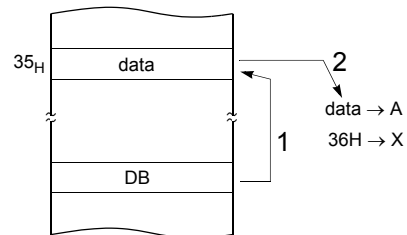

**(5) Indexed Addressing**

**X indexed direct page (no offset) → {X}**

In this mode, a address is specified by the X register.

ADC, AND, CMP, EOR, LDA, OR, SBC, STA, XMA

Example; X=15<sub>H</sub>

```
D4 LDA {X} ; ACC←RAM[X]
```

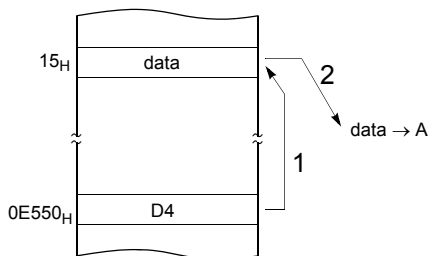

**X indexed direct page (8 bit offset) → dp+X**

This address value is the second byte (Operand) of command plus the data of X-register. And it assigns the memory in Direct page.

ADC, AND, CMP, EOR, LDA, LDY, OR, SBC, STA STY, XMA, ASL, DEC, INC, LSR, ROL, ROR

Example; X=015<sub>H</sub>

```
C645 LDA 45H+X
```

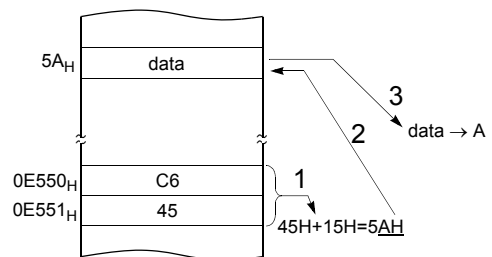

**Y indexed direct page (8 bit offset) → dp+Y**

This address value is the second byte (Operand) of command plus the data of Y-register, which assigns Memory in Direct page.

This is same with above (2). Use Y register instead of X.

**Y indexed absolute →!abs+Y**

Sets the value of 16-bit absolute address plus Y-register data as Memory. This addressing mode can specify memory in whole area.

Example; Y=55<sub>H</sub>

```
D500FA LDA !0FA00H+Y
```

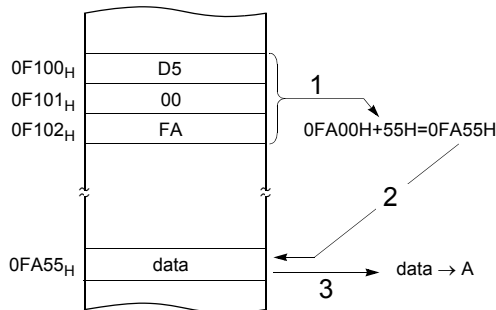

```
3F35 JMP [35H]
```

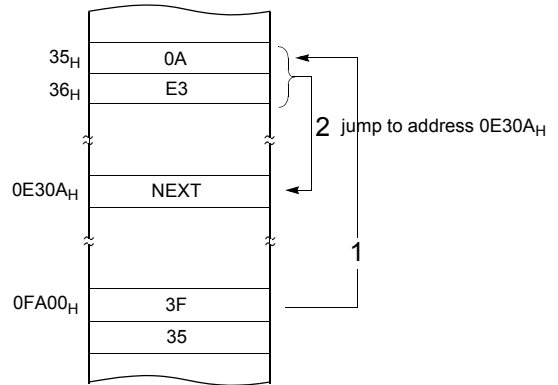

**X indexed indirect → [dp+X]**

Processes memory data as Data, assigned by 16-bit pair memory which is determined by pair data [dp+X+1][dp+X] Operand plus X-register data in Direct page.

ADC, AND, CMP, EOR, LDA, OR, SBC, STA

Example; X=10<sub>H</sub>

```
1 625 ADC [25H+X]
```

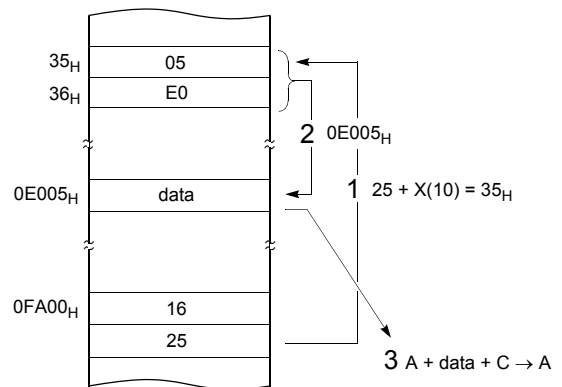

**(6) Indirect Addressing**

**Direct page indirect → [dp]**

Assigns data address to use for accomplishing command which sets memory data (or pair memory) by Operand. Also index can be used with Index register X,Y.

JMP, CALL

Example;

**Y indexed indirect → [dp]+Y**

Processes memory data as Data, assigned by the data [dp+1][dp] of 16-bit pair memory paired by Operand in Direct page plus Y-register data.

ADC, AND, CMP, EOR, LDA, OR, SBC, STA

Example; Y=10<sub>H</sub>

```
1725   ADC   [25H]+Y
```

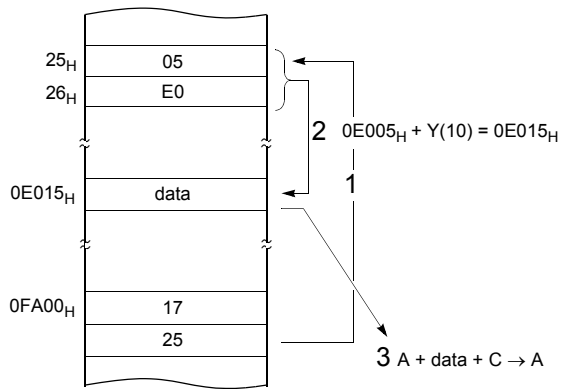

**Absolute indirect → [!abs]**

The program jumps to address specified by 16-bit absolute address.

JMP

Example;

```
1F25E0   JMP   [!0C025H]
```

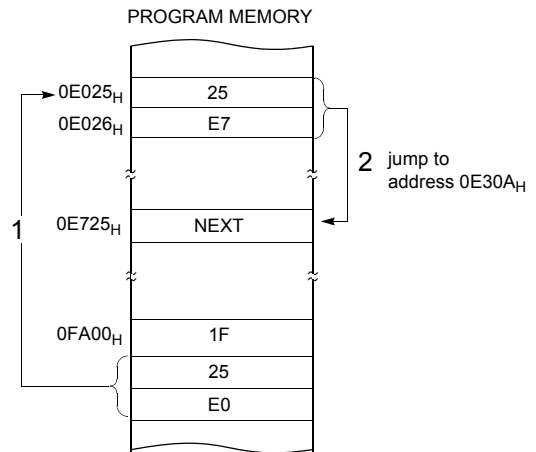

### 9. I/O PORTS

The HMS87C1816B has five ports, RA, RB, RC, RD and RE. These ports pins may be multiplexed with an alternate function for the peripheral features on the device. In general, when initial reset state, all ports are used as a general purpose input port.

All pins have data direction registers which can set these ports as output or input. A "1" in the port direction register defines the corresponding port pin as output. Conversely, write "0" to the corresponding bit to specify as an input pin. For example, to use the even numbered bit of RA as output ports and the odd numbered bits as input ports, write "55H" to address C1H (RA direction register) during initial setting as shown in Figure 9-1 .

Reading data register reads the status of the pins whereas writing

to it will write to the port latch.

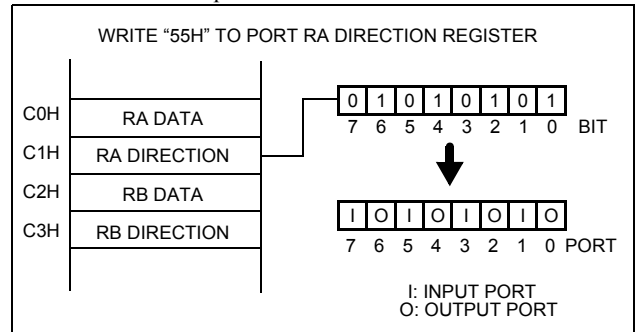

Figure 9-1 Example of port I/O assignment

#### 9.1 RA and RAIO registers

RA is an 8-bit bidirectional I/O port (address C0H). Each port can be set individually as input and output through the RAIO register (address C1H).

RA7~RA1 ports are multiplexed with Analog Input Port (AN7~AN1) and RA0 port is multiplexed with Event Counter Input Port (EC0).

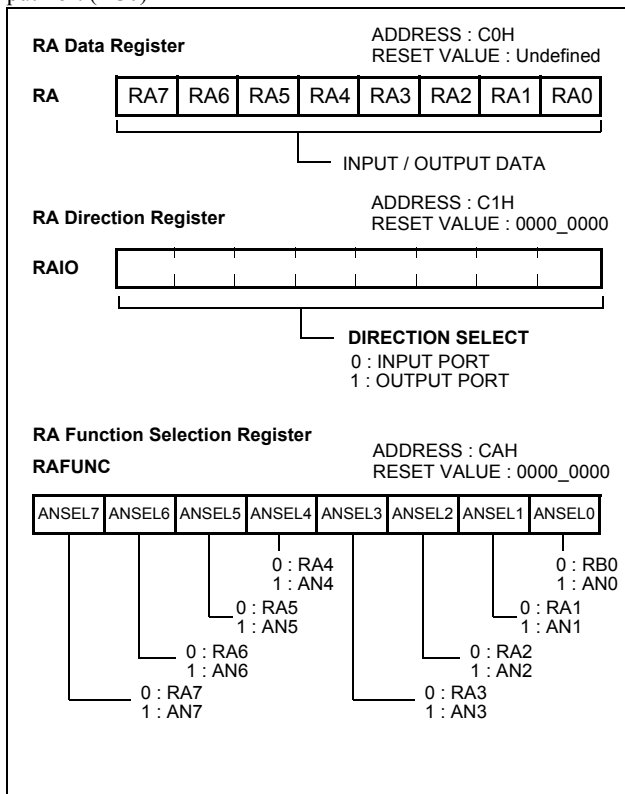

Figure 9-2 Registers of Port RA

The control register RAFUNC (address CAH) controls to select alternate function. After reset, this value is "0", port may be used as general I/O ports. To select alternate function such as Analog Input or External Event Counter Input, write "1" to the corresponding bit of RAFUNC. Regardless of the direction register RAIO, RAFUNC is selected to use as alternate functions, port pin can be used as a corresponding alternate features (RA0/EC0 is controlled by TOCK2~0 of TM0)

PORT	RAFUNC.7~0	Description
RA7/AN7	0	RA7 (Normal I/O Port)
	1	AN7 (ADS2~0=111)
RA6/AN6	0	RA6 (Normal I/O Port)
	1	AN6 (ADS2~0=110)
RA5/AN5	0	RA5 (Normal I/O Port)
	1	AN5 (ADS2~0=101)
RA4/AN4	0	RA4 (Normal I/O Port)
	1	AN4 (ADS2~0=100)
RA3/AN3	0	RA3 (Normal I/O Port)
	1	AN3 (ADS2~0=011)
RA2/AN2	0	RA2 (Normal I/O Port)
	1	AN2 (ADS2~0=010)
RA1/AN1	0	RA1 (Normal I/O Port)
	1	AN1 (ADS2~0=001)
RA0/EC0 <sup>1</sup>		RA0 (Normal I/O Port)
		EC0 (TOCK2~0=111)

1. This port is not an Analog Input port, but Event Counter clock source input port. ECO is controlled by setting TOCK2~0 = 111. The bit RAFUNC.0 (ANSEL0) controls the RB0/AN0/AVref port (Refer to Port RB).



### 9.2 RB and RBIO registers

RB is an 8-bit bidirectional I/O port (address C2<sub>H</sub>). Each pin can be set individually as input and output through the RBIO register (address C3<sub>H</sub>). In addition, Port RB is multiplexed with various special features. The control register RBFUNC (address CB<sub>H</sub>)

controls to select alternate function. After reset, this value is “0”, port may be used as general I/O ports. To select alternate function such as External interrupt or Timer compare output, write “1” to the corresponding bit of RBFUNC.

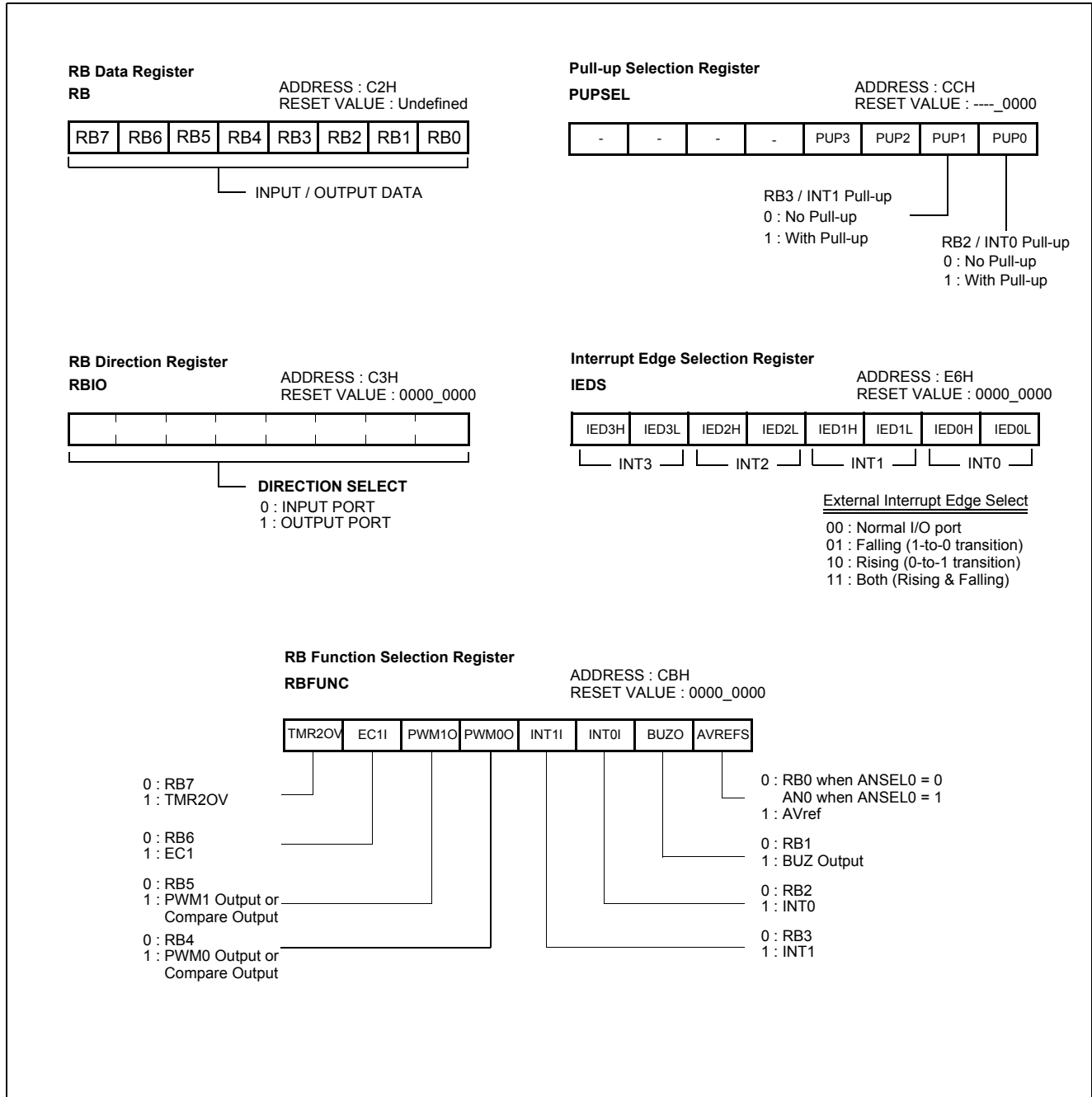

Figure 9-3 Registers of Port RB

Regardless of the direction register RBIO, RBFUNC is selected to use as alternate functions, port pin can be used as a correspond-

ing alternate features.

PORT	RBFUNC.4~0	Description
RB7/ TMR2OV	0	RB7 (Normal I/O Port)
	1	Timer2 Overflow Output
RB6/EC1	0	RB6 (Normal I/O Port)
	1	Event Counter 1 Input
RB5/ PWM1/ COMP1	0	RB5 (Normal I/O Port)
	1	PWM1 Output / Timer3 Compare Output
RB4/ PWM0/ COMP0	0	RB4 (Normal I/O Port)
	1	PWM0 Output / Timer1 Compare Output
RB3/INT1	0	RB3 (Normal I/O Port)
	1	External Interrupt Input 1
RB2/INT0	0	RB2 (Normal I/O Port)
	1	External Interrupt Input 0
RB1/BUZ	0	RB1 (Normal I/O Port)
	1	Buzzer Output
RB0/AN0/ AVref	0 <sup>1</sup>	RB0 (Normal I/O Port)/ AN0 (ANSEL0=1)
	1 <sup>2</sup>	External Analog Reference Voltage

1. When ANSEL0 = "0", this port is defined for normal I/O port (RB0).

When ANSEL0 = "1" and ADS2~0 = "000", this port can be used Analog Input Port (AN0).

2. When this bit set to "1", this port defined for AVref, so it can not be used Analog Input Port AN0 and Normal I/O Port RB0.

### 9.3 RC and RCIO registers

RC is an 8-bit bidirectional I/O port (address C4<sub>H</sub>). Each pin can be set individually as input and output through the RCIO register (address C5<sub>H</sub>).

In addition, Port RC is multiplexed with Serial Peripheral Interface (SPI).

The control register SIOM (address E0<sub>H</sub>) controls to select Serial Peripheral Interface function.

After reset, the RCIO register value is “0”, port may be used as general I/O ports. To select Serial Peripheral Interface function, write “1” to the corresponding bit of SIOM.

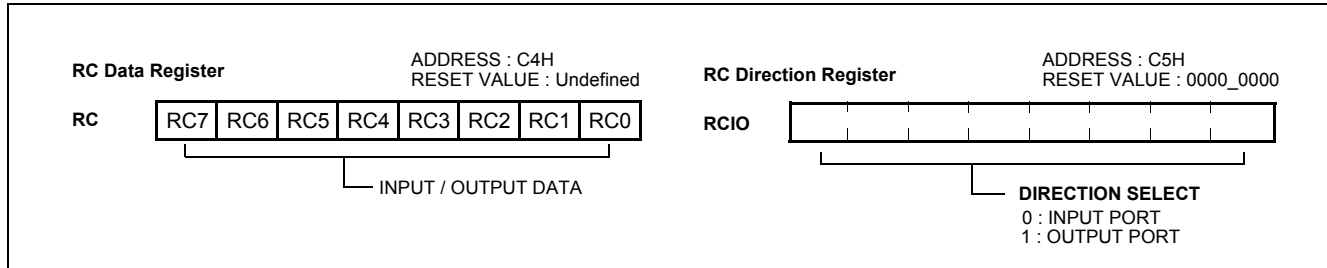

Figure 9-4 Registers of Port RC

PORT	Function	SIOM			Description
		SRDY	SM [1:0]	SCK [1:0]	
RC6/ SOUT	RC6	X	X:0	X:X	RC6 (Normal I/O Port)
	SOUT	X	X:1	X:X	SPI Serial Data Output
RC5/ SIN	RC5	X	0:X	X:X	RC5 (Normal I/O Port)
	SIN	X	1:X	X:X	SPI Serial Data Input
RC4/ SCK	RC4	X	0:0	X:X	RC4 (Normal I/O Port)
	SCKO	X	0:0	00, 01, 10	SPI Synchronous Clock Output
	SCKI	X	0:0	1:1	SPI Synchronous Clock Input
RC3/ SRDY	RC3	0	X:X	X:X	RC3 (Normal I/O Port)
	$\overline{\text{SRDYIN}}$	1	X:X	00, 01, 10	SPI Ready Input (Master Mode)
	$\overline{\text{SRDYOUT}}$	1	X:X	1:1	SPI Ready Output (Slave Mode)

Table 9-1 Serial Communication Functions in RC Port

### 9.4 RD and RDIO registers

RD is an 8-bit bidirectional I/O port (address C6<sub>H</sub>). Each pin can be set individually as input and output through the RDIO register

(address C7<sub>H</sub>).

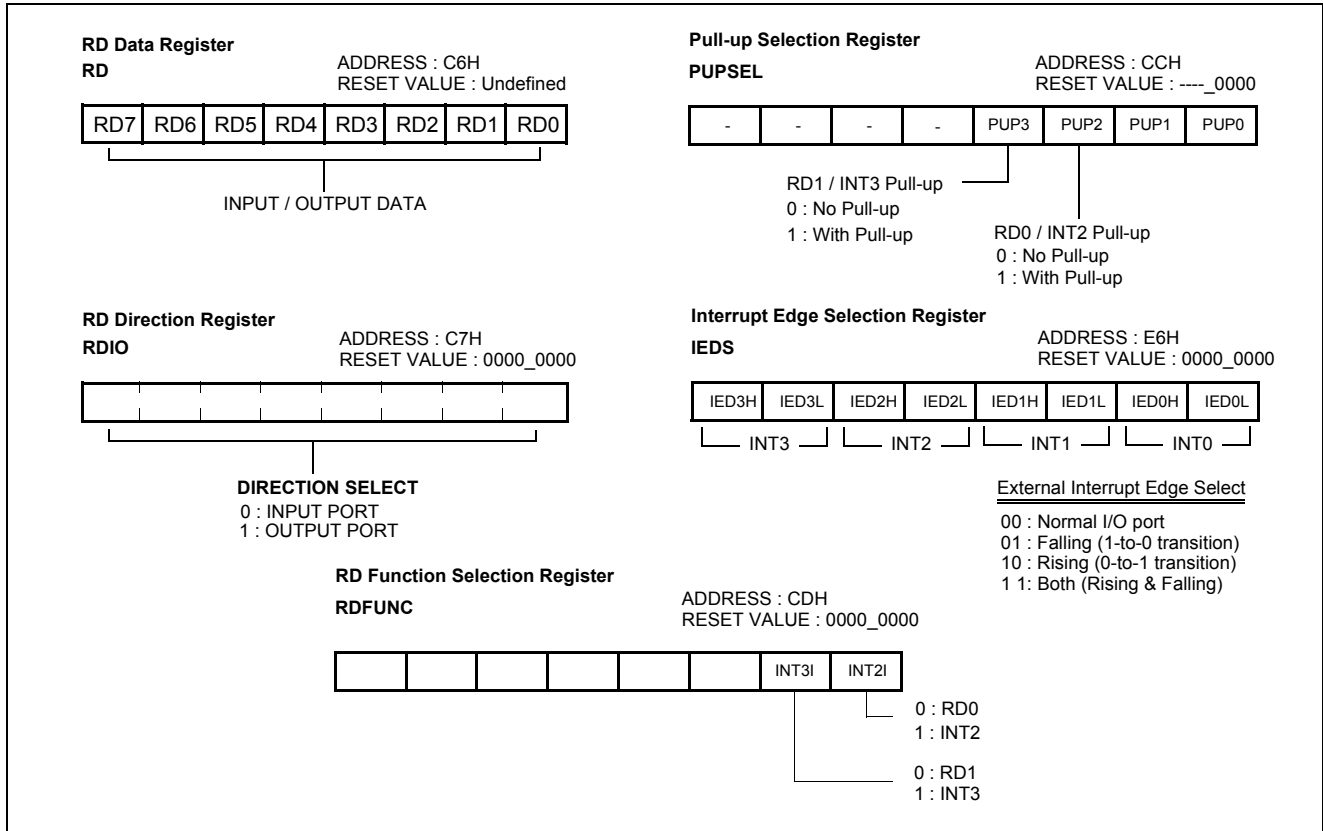

Figure 9-5 Registers of Port RD

In addition, Port RD is multiplexed with external interrupt input function. The control register RDFUNC (address CD<sub>H</sub>) controls to select alternate function. After reset, this value is “0”, port may be used as general I/O ports. To select alternate function, write “1” to the corresponding bit of RDFUNC.

Regardless of the direction register RDIO, RDFUNC is selected to use as external interrupt input function, port pin can be used as an interrupt input feature.

### 9.5 RE and REIO registers

RE is a 7-bit bidirectional I/O port (address C8<sub>H</sub>). Each pin can be set individually as input and output through the REIO register

(address C9<sub>H</sub>).

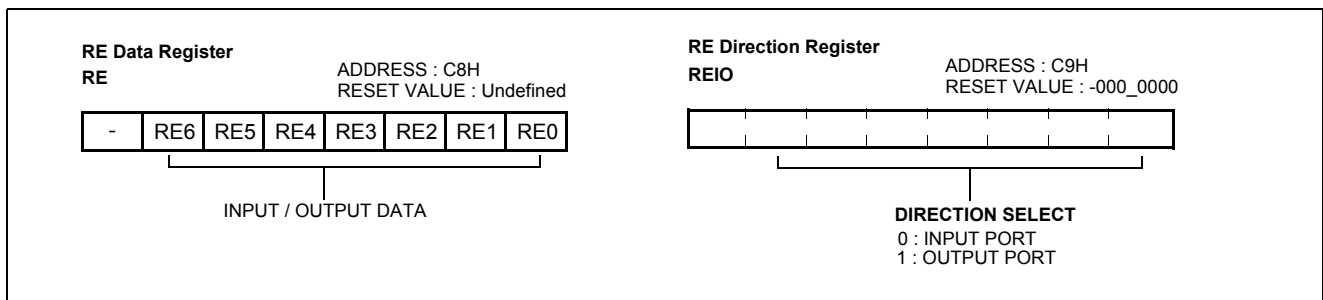

Figure 9-6 Registers of Port RE

## 10. CLOCK GENERATOR

The clock generator produces the basic clock pulses which provide the system clock to be supplied to the CPU and peripheral hardware. The main system clock oscillator oscillates with a crystal resonator or a ceramic resonator connected to the Xin and

Xout pins. External clocks can be input to the main system clock oscillator. In this case, input a clock signal to the Xin pin and open the Xout pin.

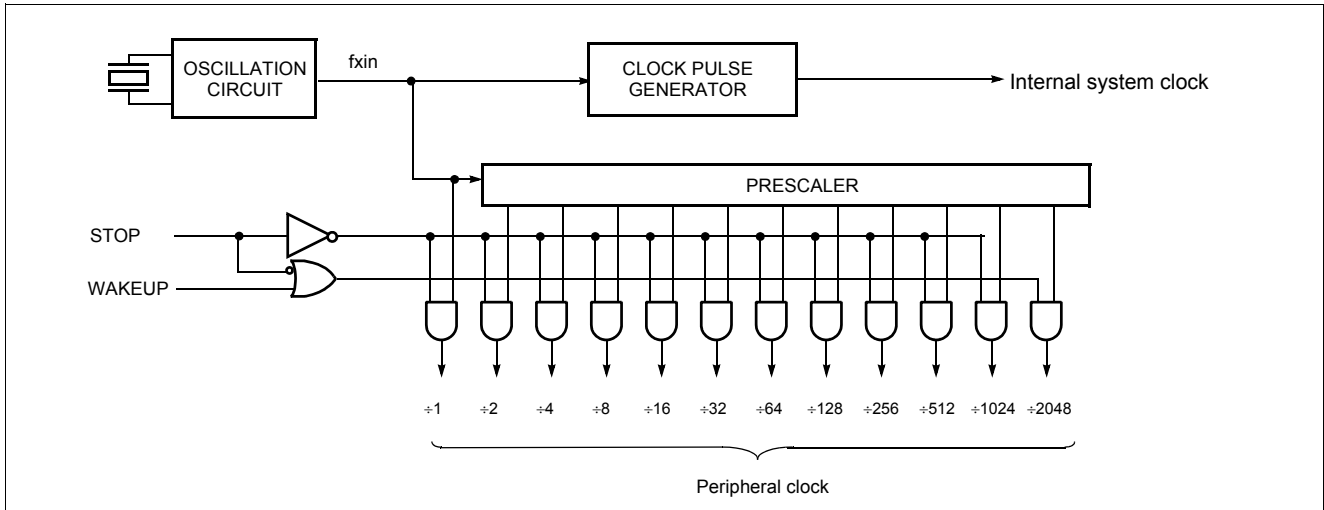

Figure 10-1 Block Diagram of Clock Pulse Generator

### 10.1 Oscillation Circuit

$X_{IN}$  and  $X_{OUT}$  are the input and output, respectively, a inverting amplifier which can be set for use as an on-chip oscillator, as shown in Figure 10-2 .

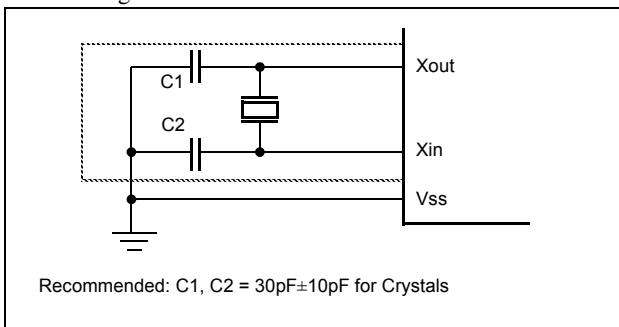

Figure 10-2 Oscillator Connections

To drive the device from an external clock source, Xout should be left unconnected while Xin is driven as shown in Figure 10-3 . There are no requirements on the duty cycle of the external clock signal, since the input to the internal clocking circuitry is through a divide-by-two flip-flop, but minimum and maximum high and low times specified on the data sheet must be observed.

Oscillation circuit is designed to be used either with a ceramic resonator or crystal oscillator. Since each crystal and ceramic resonator have their own characteristics, the user should consult the crystal manufacturer for appropriate values of external compo-

nents.

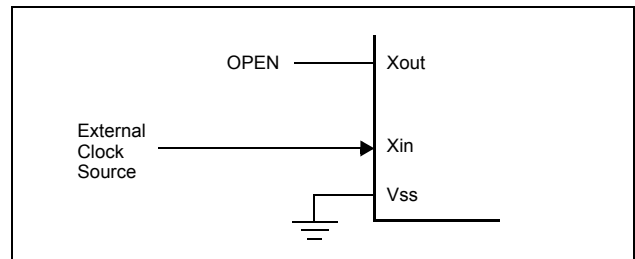

Figure 10-3 External Clock Connections

**Note:** When using a system clock oscillator, carry out wiring in the broken line area in Figure 10-2 to prevent any effects from wiring capacities.

- Minimize the wiring length.
- Do not allow wiring to intersect with other signal conductors.
- Do not allow wiring to come near changing high current.
- Set the potential of the grounding position of the oscillator capacitor to that of Vss. Do not ground to any ground pattern where high current is present.
- Do not fetch signals from the oscillator.

In addition, the HMS87C1X04B/08B/16B has an ability for the external RC oscillated operation. It offers additional cost savings for **timing insensitive applications**. The RC oscillator frequency is a function of the supply voltage, the external resistor ( $R_{EXT}$ ) and capacitor ( $C_{EXT}$ ) values, and the operating temperature.

The user needs to take into account variation due to tolerance of external R and C components used.

Figure 10-4 shows how the RC combination is connected to the HMS87C1X04B/08B/16B.

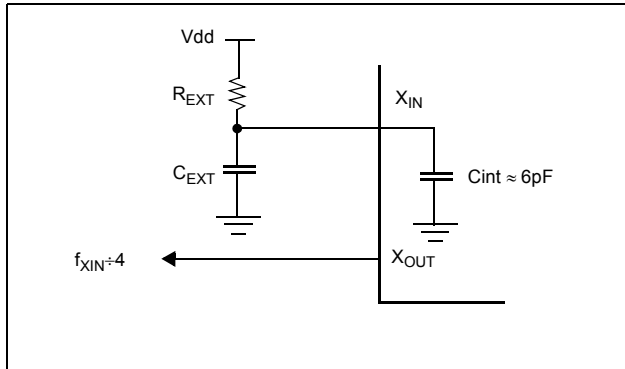

**Figure 10-4 RC Oscillator Connections**

External capacitor ( $C_{EXT}$ ) can be omitted for more cost saving. However, the characteristics of external R only oscillation are more variable than external RC oscillation.

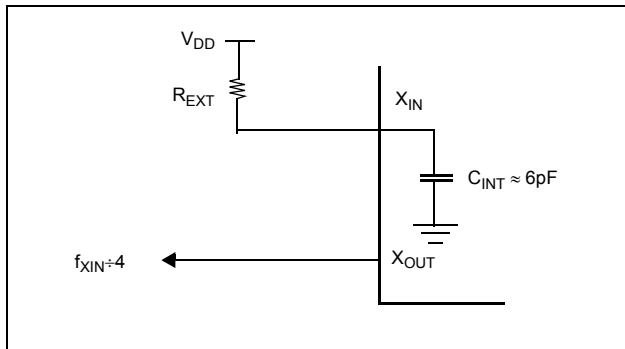

**Figure 10-5 R Oscillator Connections**

The oscillator frequency, divided by 4, is output from the Xout pin, and can be used for test purpose or to synchronize other logic.

To set the RC oscillation, it should be programmed RC\_osc bit of the configuration memory (CONFIG : 707Fh) to "1". ( Refer to Section "21.3". )

In addition to external crystal/resonator and external RC/R oscillation, the HMS81C1X04B/08B/16B provides the internal 4MHz oscillation. The internal 4MHz oscillation needs no external parts.

Figure 10-6 shows the pin connections in case of using the internal 4MHz oscillation as the system clock.

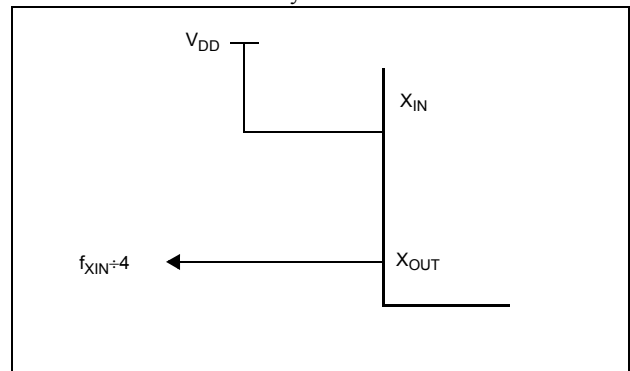

**Figure 10-6 Internal 4MHz Connections**

To use the internal 4MHz oscillation, it should be programmed ONPb bit and IN\_CLK bit of the configuration memory (CONFIG : 707FH) to "0" and "1" respectively. ( Refer to Section "21.3". )

### 11. Basic Interval Timer

The HMS87C1X04B/08B/16B has one 8-bit Basic Interval Timer that is free-run, can not stop. Block diagram is shown in Figure 11-1. The 8-bit Basic interval timer register (BITR) is increased every internal count pulse which is divided by prescaler. Since prescaler has divided ratio by 8 to 1024, the count rate is 1/8 to 1/1024 of the oscillator frequency. As the count overflows from FF<sub>H</sub> to 00<sub>H</sub>, this overflow causes to generate the Basic interval timer interrupt. The BITIF is interrupt request flag of Basic interval timer.

When write “1” to bit BTCL of CKCTLR, BITR register is cleared to “0” and restart to count-up. The bit BTCL becomes “0” after one machine cycle by hardware.

If the STOP instruction executed after writing “1” to bit WAKEUP of CKCTLR, it goes into the wake-up timer mode. In this mode, all of the block is halted except the oscillator, prescaler

(only f<sub>xin</sub>÷2048) and Timer0.

If the STOP instruction executed after writing “1” to bit RCWDT of CKCTLR, it goes into the internal RC oscillated watchdog timer mode. In this mode, all of the block is halted except the internal RC oscillator, Basic Interval Timer and Watchdog Timer. More detail informations are explained in Power Saving Function. The bit WDTON decides Watchdog Timer or the normal 7-bit timer

**Note:** All control bits of Basic interval timer are in CKCTLR register which is located at same address of BITR (address EC<sub>H</sub>). Address EC<sub>H</sub> is read as BITR, written to CKCTLR. Therefore, the CKCTLR can not be accessed by bit manipulation instruction.

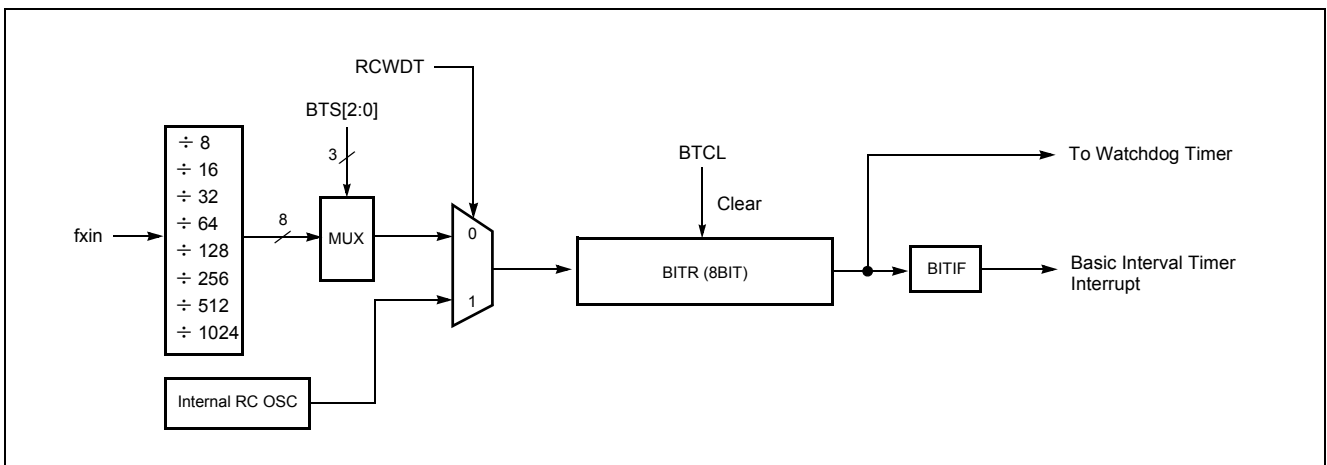

Figure 11-1 Block Diagram of Basic Interval Timer

Clock Control Register									
CKCTLR	-	WAKEUP	RCWDT	WDTON	BTCL	BTS2	BTS1	BTS0	ADDRESS : EC <sub>H</sub> RESET VALUE : -001_0111 Bit Manipulation Not Available
Symbol	Function Description							<b>Basic Interval Timer Clock Selection</b>	
WAKEUP	1 : Enables Wake-up Timer 0 : Disables Wake-up Timer							000 : f <sub>xin</sub> ÷ 8 001 : f <sub>xin</sub> ÷ 16 010 : f <sub>xin</sub> ÷ 32 011 : f <sub>xin</sub> ÷ 64 100 : f <sub>xin</sub> ÷ 128 101 : f <sub>xin</sub> ÷ 256 110 : f <sub>xin</sub> ÷ 512 111 : f <sub>xin</sub> ÷ 1024	
RCWDT	1 : Enables Internal RC Watchdog Timer 0 : Disables Internal RC Watchdog Time								
WDTON	1 : Enables Watchdog Timer 0 : Operates as a 7-bit Timer								
BTCL	1 : BITR is cleared and BTCL becomes “0” automatically after one machine cycle, and BITR continue to count-up								

Figure 11-2 CKCTLR: Clock Control Register

## 12. TIMER / COUNTER

The HMS87C1X04B/08B/16B has four Timer/Counter registers. Each module can generate an interrupt to indicate that an event has occurred (i.e. timer match).

Timer 0 and Timer 1 can be used either the two 8-bit Timer/Counter or one 16-bit Timer/Counter by combining them. Also Timer 2 and Timer 3 are same. In this document, explain Timer 0 and Timer 1 because Timer2 and Timer3 same with Timer 0 and Timer 1.

In the “timer” function, the register is increased every internal clock input. Thus, one can think of it as counting internal clock input. Since the least clock consists of 2 and the most clock consists of 2048 oscillator periods, the count rate is 1/2 to 1/2048 of the oscillator frequency in Timer0. And Timer1 can use the same clock source too. In addition, Timer1 has more fast clock source (1/1 to 1/8).

In the “counter” function, the register is increased in response to a 0-to-1 (rising edge) transition at its corresponding external input pin, EC0(Timer 0) or EC1(Timer 2).

**Note:** In the external event counter function, the RA0/EC0 pin has not a schmitt trigger, but a normal input port. Therefore, it may be count more than input event signal if the noise interfere in slow transition input signal .

In addition the “capture” function, the register is increased in response external interrupt same with timer function. When external interrupt edge input, the count register is captured into capture data register CDRx.

Timer1 and Timer 3 are shared with “PWM” function and “Compare output” function

It has seven operating modes: “8-bit timer/counter”, “16-bit timer/counter”, “8-bit capture”, “16-bit capture”, “8-bit compare output”, “16-bit compare output” and “10-bit PWM” which are selected by bit in Timer mode register TMx as shown in Figure 12-1 and Table 12-1 .

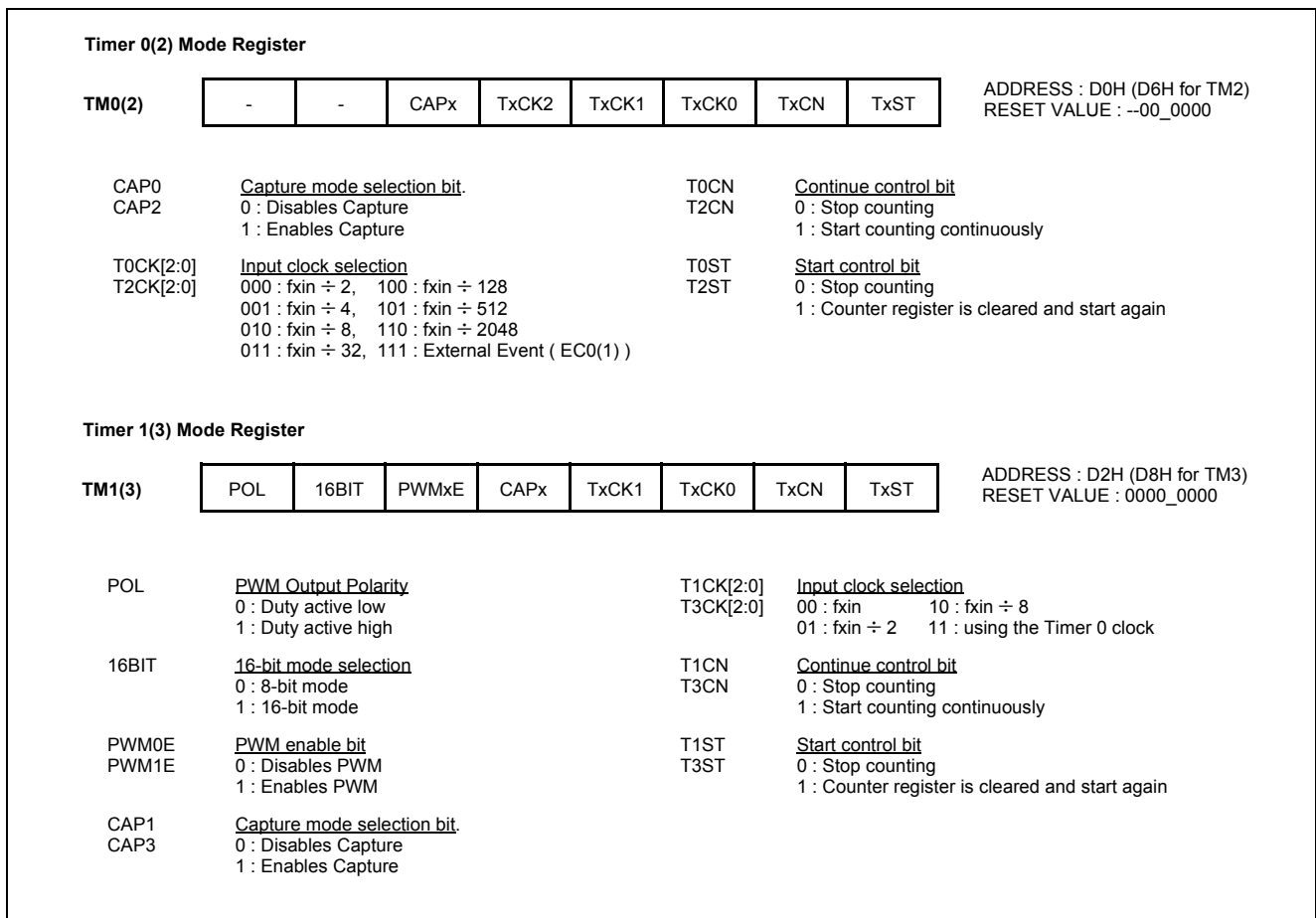

Figure 12-1 Timer Mode Register (TMx, x = 0~3)



16BIT	CAP0	CAP1	PWME	T0CK[2:0]	T1CK[1:0]	PWMO	TIMER 0	TIMER1
0	0	0	0	XXX	XX	0	8-bit Timer	8-bit Timer
0	0	1	0	111	XX	0	8-bit Event Counter	8-bit Capture
0	1	0	0	XXX	XX	1	8-bit Capture	8-bit Compare output
0	X <sup>1</sup>	0	1	XXX	XX	1	8-bit Timer/Counter	10-bit PWM
1	0	0	0	XXX	11	0	16-bit Timer	
1	0	0	0	111	11	0	16-bit Event Counter	
1	1	X	0	XXX	11	0	16-bit Capture	
1	0	0	0	XXX	11	1	16-bit Compare output	

**Table 12-1 Operating Modes of Timer 0 and Timer 1**

1. X: The value "0" or "1" corresponding your operation.

### 12.1 8-bit Timer/Counter Mode

The HMS87C1X04B/08B/16B has four 8-bit Timer/Counters, Timer 0, Timer 1, Timer 2 and Timer 3, as shown in Figure 12-2.

The "timer" or "counter" function is selected by mode registers

TMx as shown in Figure 12-1 and Table 12-1. To use as an 8-bit timer/counter mode, bit CAP0 of TM0 is cleared to "0" and bits 16BIT of TM1 should be cleared to "0" (Table 12-1).

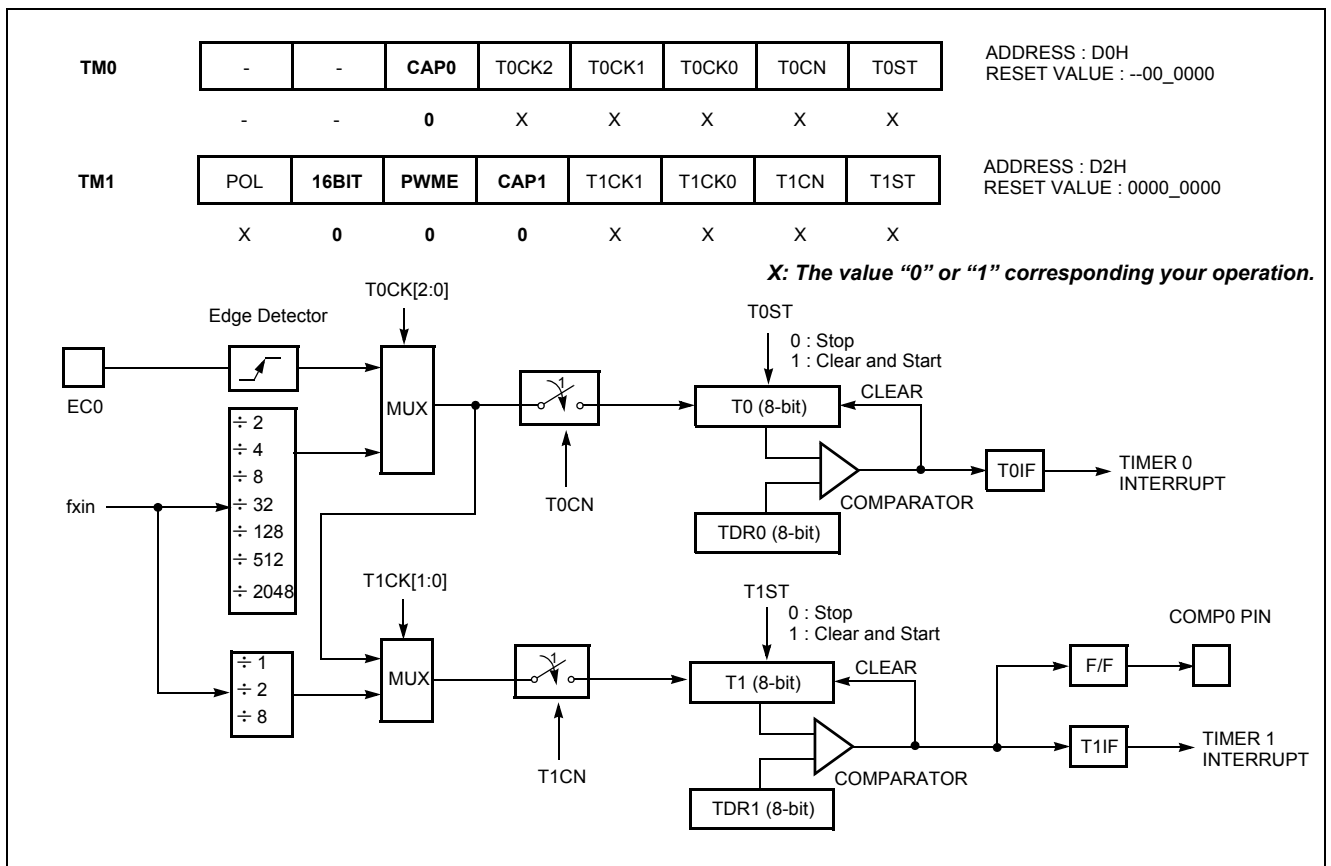

**Figure 12-2 8-bit Timer / Counter Mode**

These timers have each 8-bit count register and data register. The

count register is increased by every internal or external clock in-

put. The internal clock has a prescaler divide ratio option of 2, 4, 8, 32, 128, 512, 2048 (selected by control bits T0CK2, T0CK1 and T0CK0 of register TM0) and 1, 2, 8 (selected by control bits T1CK1 and T1CK0 of register TM1). In the Timer 0, timer register T0 increases from 00<sub>H</sub> until it matches TDR0 and then reset to 00<sub>H</sub>. The match output of Timer 0 generates Timer 0 interrupt (latched in T0F bit). As TDR<sub>x</sub> and Tx register are in same address, when reading it as a Tx, written to TDR<sub>x</sub>.

dress, when reading it as a Tx, written to TDR<sub>x</sub>.

In counter function, the counter is increased every 0-to 1 (rising edge) transition of EC0 pin. In order to use counter function, the bit RA0 of the RA Direction Register RAIO is set to "0". The Timer 0 can be used as a counter by pin EC0 input, but Timer 1 can not.

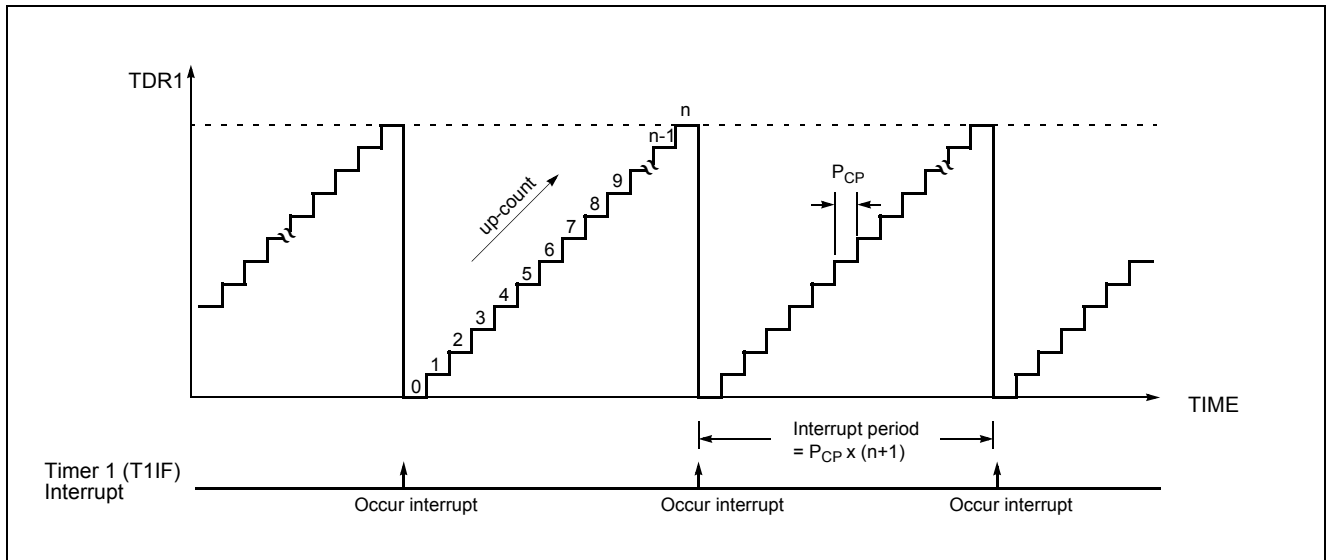

Figure 12-3 Counting Example of Timer Data Registers

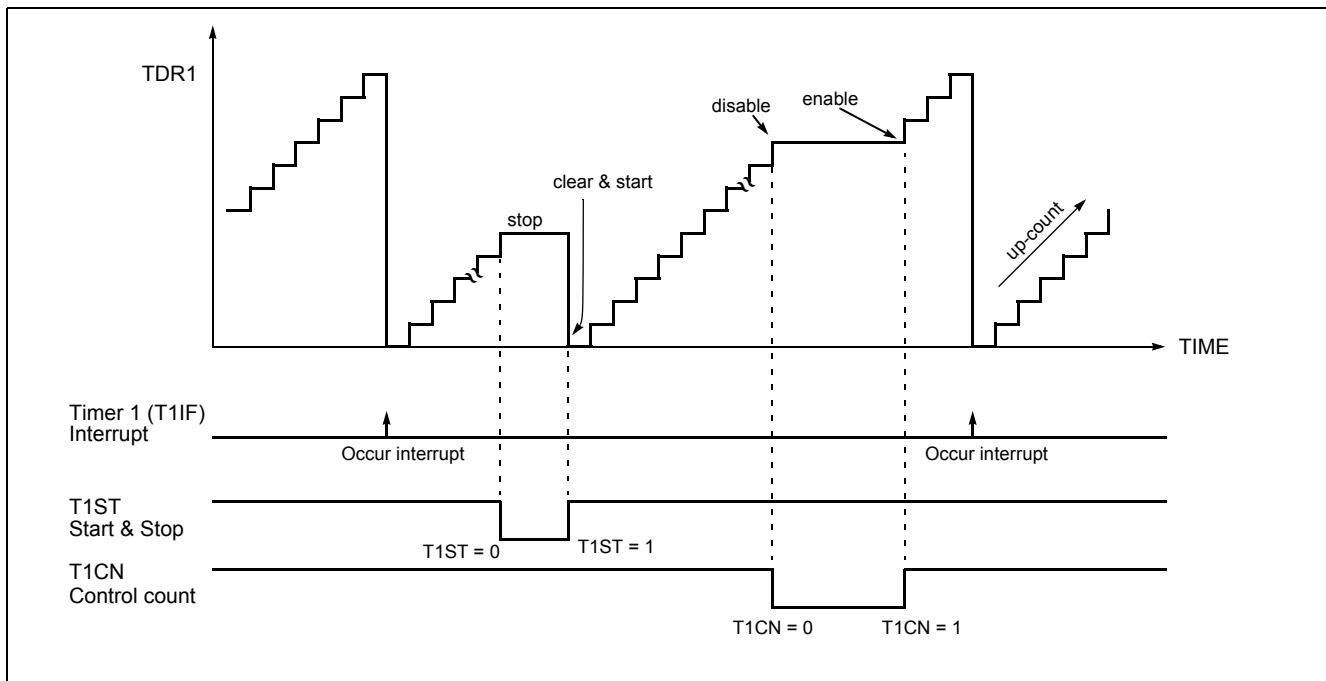

Figure 12-4 Timer Count Operation

### 12.2 16-bit Timer/Counter Mode

The Timer register is being run with 16 bits. A 16-bit timer/coun-

ter register T0, T1 are increased from 0000<sub>H</sub> until it matches

TDR0, TDR1 and then resets to 0000<sub>H</sub>. The match output generates Timer 0 interrupt not Timer 1 interrupt.

In 16-bit mode, the bits T1CK1, T1CK0 and 16BIT of TM1 should be set to "1" respectively.

The clock source of the Timer 0 is selected either internal or external clock by bit T0CK2, T0CK1 and T0SL0.

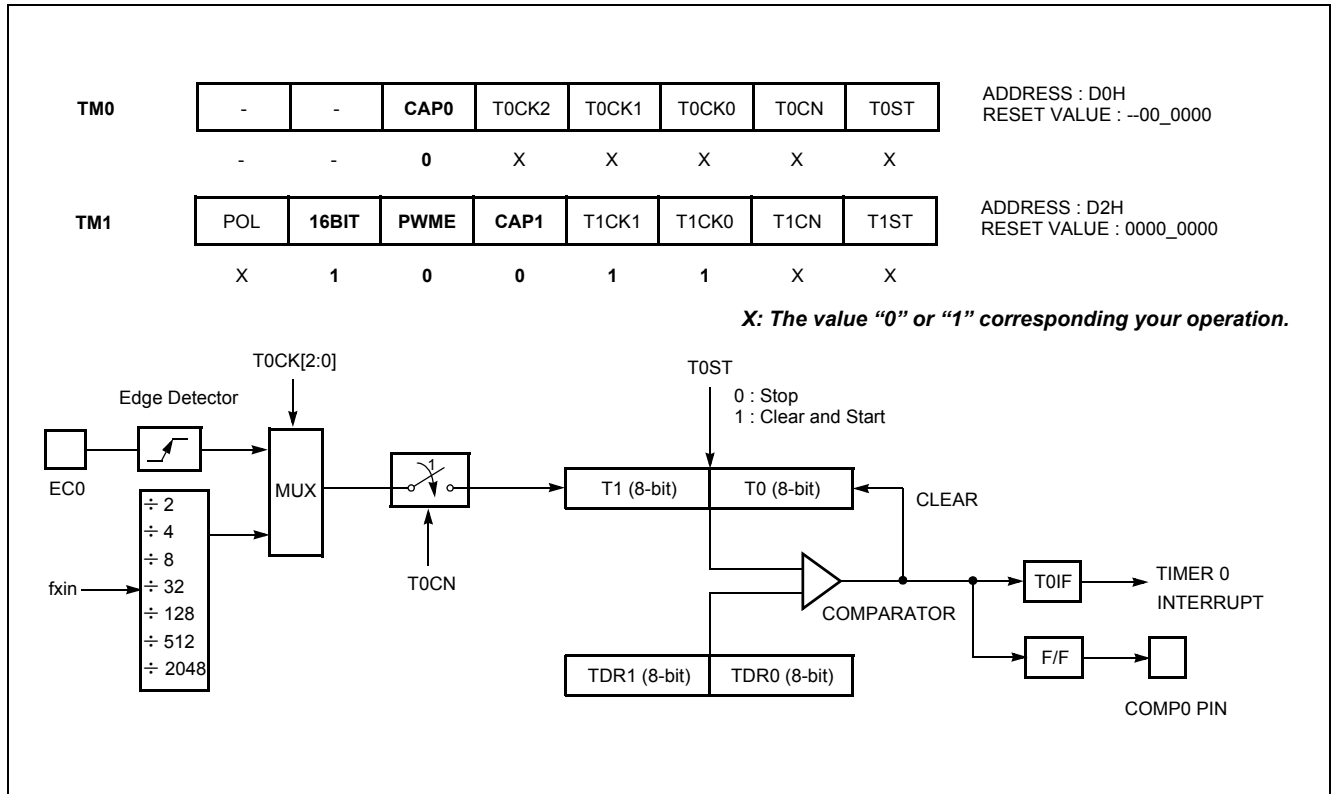

Figure 12-5 16-bit Timer / Counter Mode

### 12.3 8-bit Compare Output (16-bit)

The HMS87C1X04B/08B/16B has a function of Timer Compare Output. To pulse out, the timer match can go to port pin(COMP0) as shown in Figure 12-2 and Figure 12-5. Thus, pulse out is generated by the timer match. These operation is implemented to pin, RB4/COMP0/PWM.

output frequency is same as below equation.

$$f_{COMP} = \frac{Oscillation\ Frequency}{2 \times Prescaler\ Value \times (TDR + 1)}$$

This pin output the signal having a 50: 50 duty square wave, and

In this mode, the bit PWMO of RB function register (RBFUNC) should be set to "1", and the bit PWME of timer1 mode register (TM1) should be set to "0".

In addition, 16-bit Compare output mode is available, also.

### 12.4 8-bit Capture Mode

The Timer 0 capture mode is set by bit CAP0 of timer mode register TM0 (bit CAP1 of timer mode register TM1 for Timer 1) as shown in Figure 12-6.

(T1) increases and matches TDR0 (TDR1).

As mentioned above, not only Timer 0 but Timer 1 can also be used as a capture mode.

In the capture mode, the timer interrupt is very useful when the pulse width of captured signal is more wider than the maximum period of Timer.

The Timer/Counter register is increased in response internal or external input. This counting function is same with normal timer mode, and Timer interrupt is generated when timer register T0

For example, in Figure 12-8, the pulse width of captured signal is wider than the timer data value (FF<sub>H</sub>) over 2 times. When external interrupt is occurred, the captured value (13<sub>H</sub>) is more little than wanted value. It can be obtained correct value by counting

the number of timer overflow occurrence.

Timer/Counter still does the above, but with the added feature that a edge transition at external input INTx pin causes the current value in the Timer x register (T0,T1), to be captured into registers CDRx (CDR0, CDR1), respectively. After captured, Timer x register is cleared and restarts by hardware.

It has three transition modes: “falling edge”, “rising edge”, “both edge” which are selected by interrupt edge selection register IEDS (Refer to External interrupt section). In addition, the transi-

tion at INTx pin generate an interrupt.

**Note:** The CDRx, TDRx and Tx are in same address. In the capture mode, reading operation read the CDRx, not Tx because the reading path is opened to the CDRx, and TDRx is read while writing operation executed.

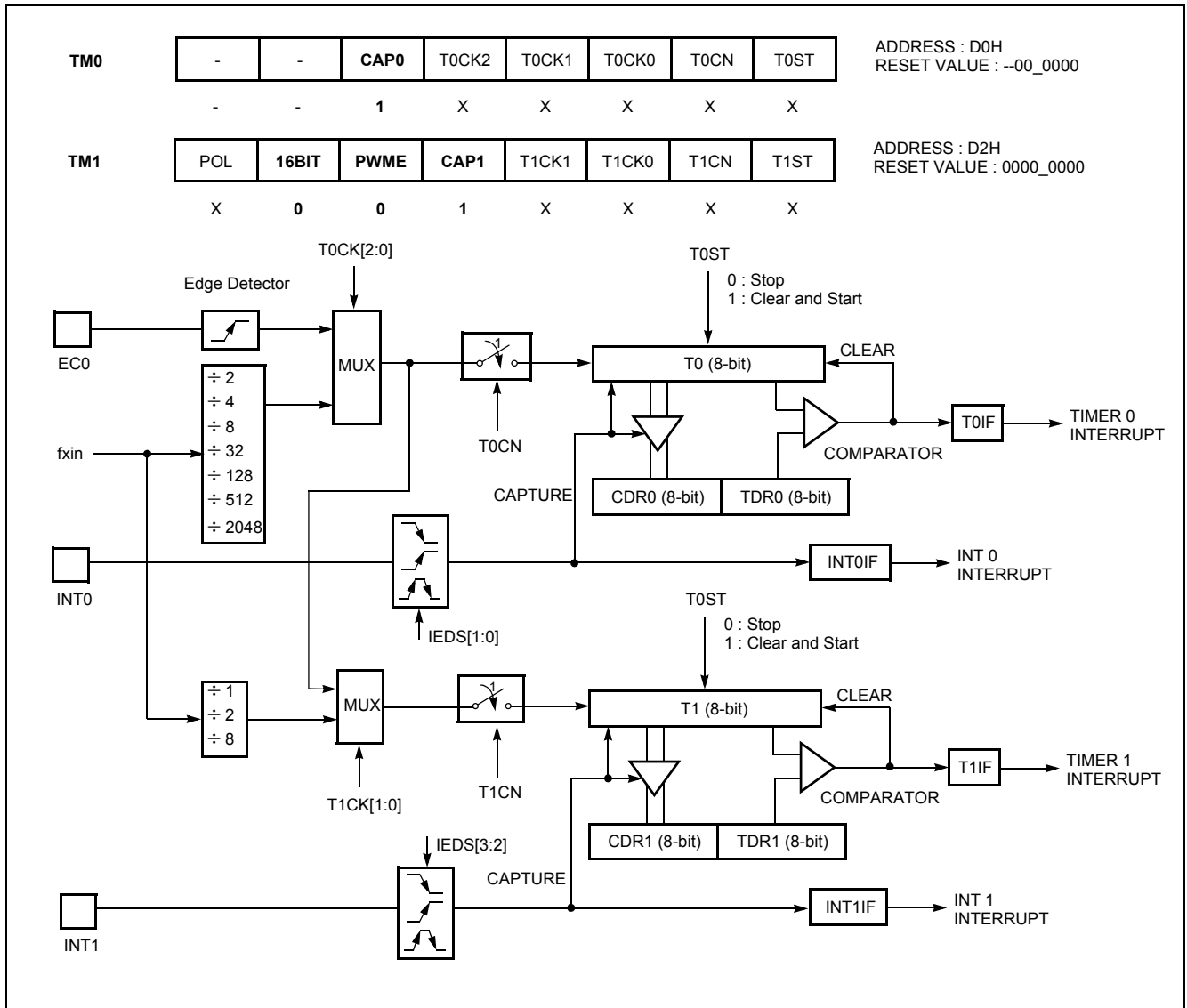

Figure 12-6 8-bit Capture Mode

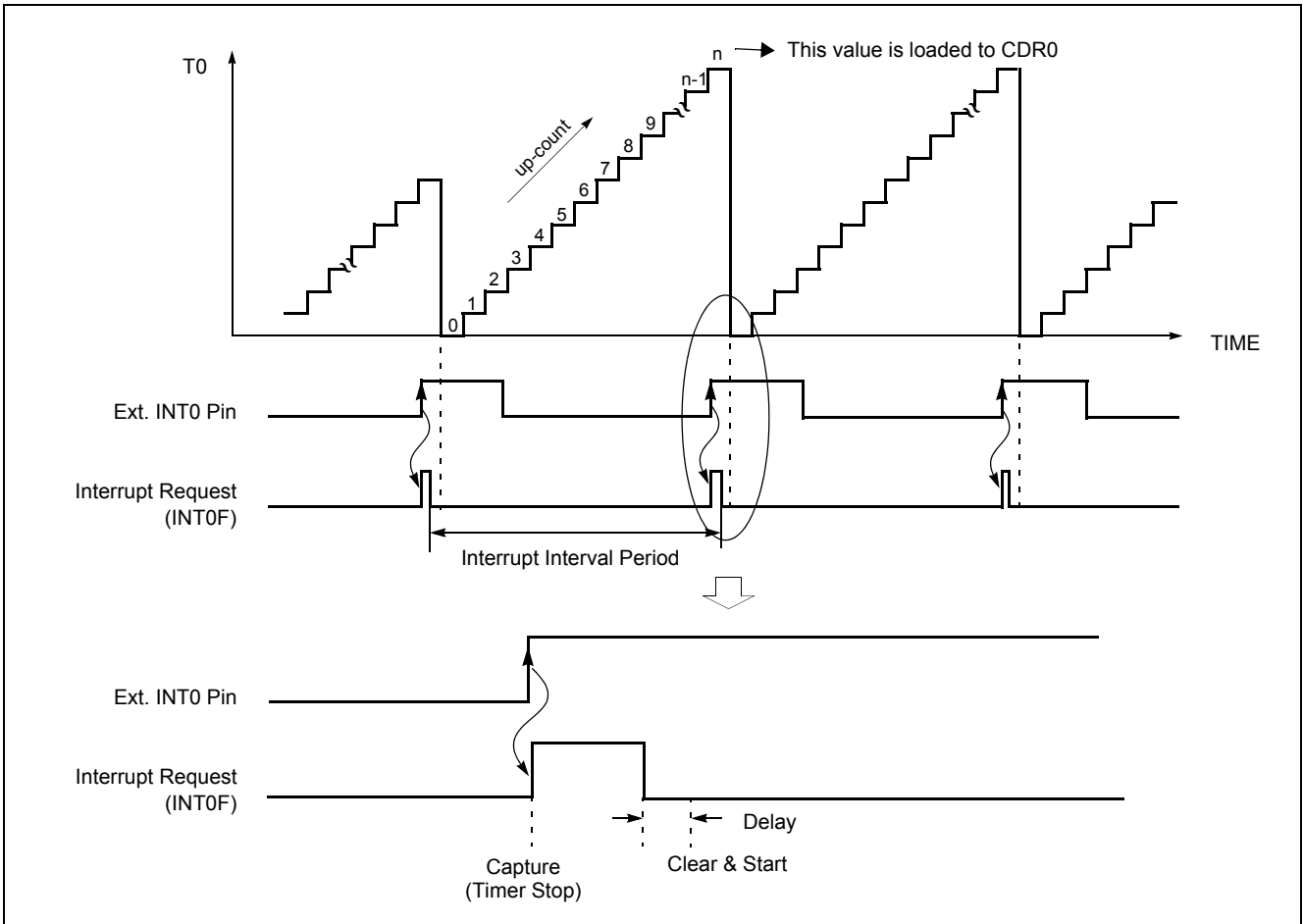

Figure 12-7 Input Capture Operation

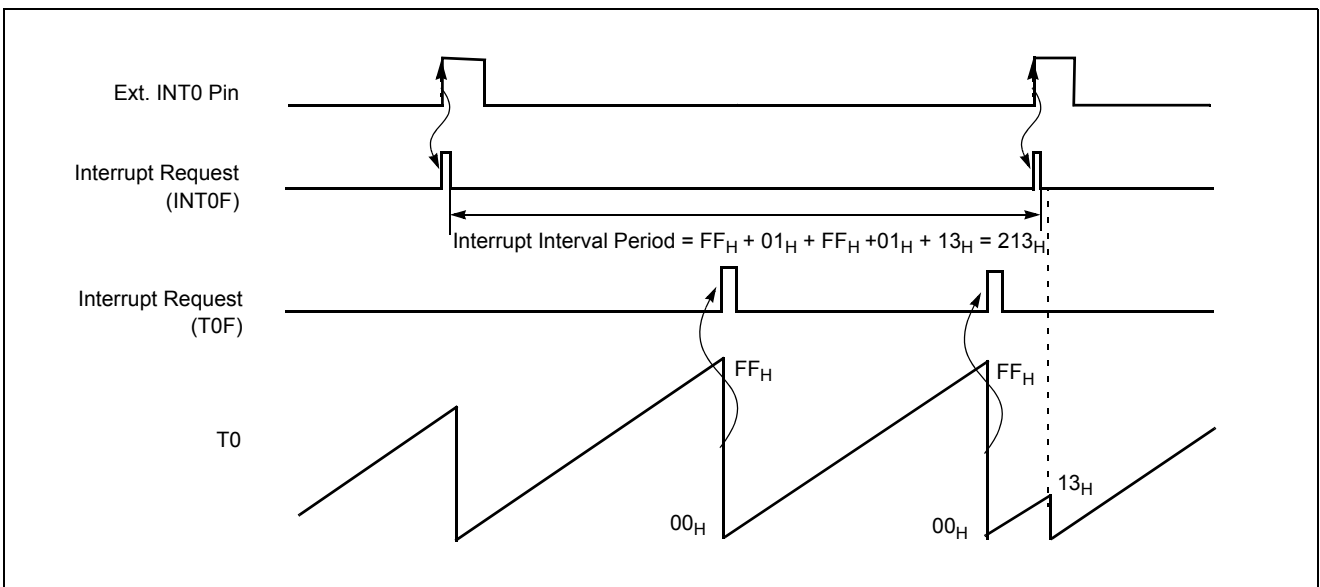

Figure 12-8 Excess Timer Overflow in Capture Mode

### 12.5 16-bit Capture Mode

16-bit capture mode is the same as 8-bit capture, except that the Timer register is being run will 16 bits.

The clock source of the Timer 0 is selected either internal or external clock by bit T0CK2, T0CK1 and T0CK0.

In 16-bit mode, the bits T1CK1, T1CK0 and 16BIT of TM1 should be set to "1" respectively.

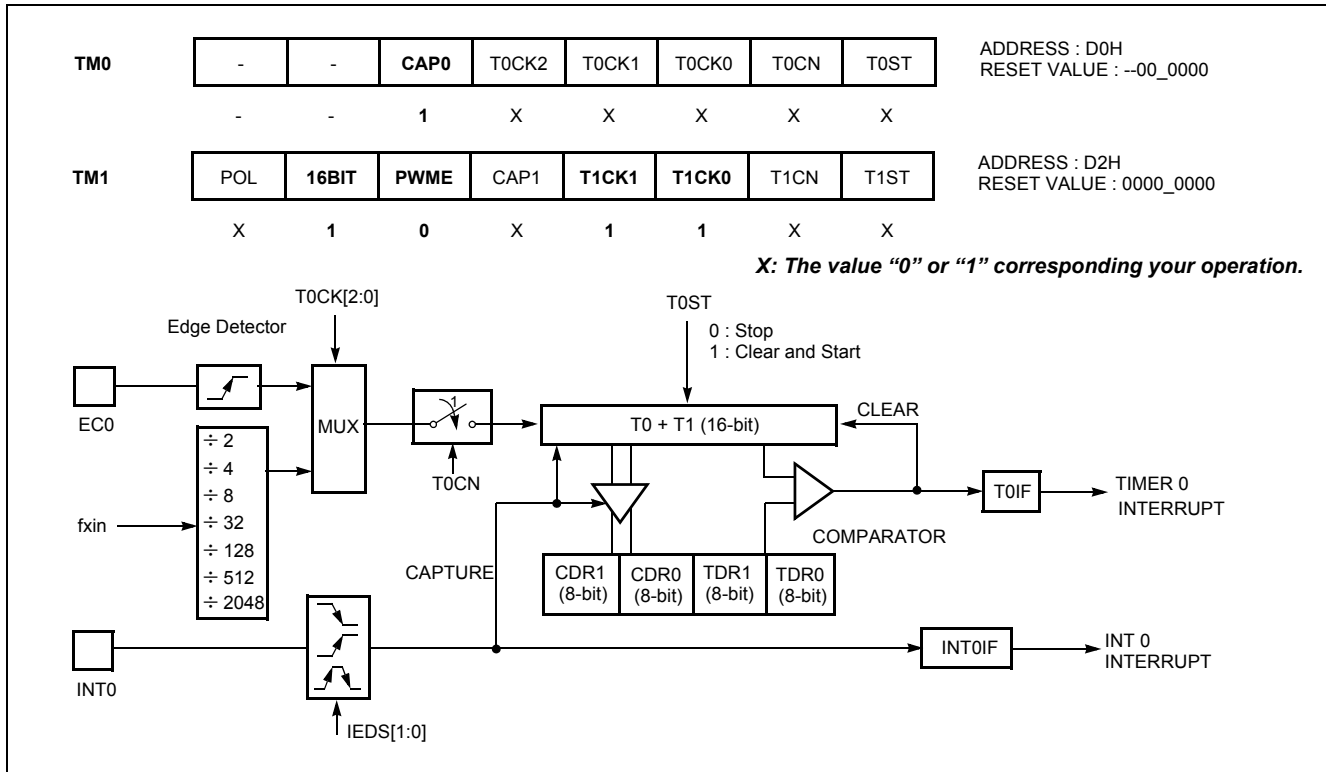

Figure 12-9 16-bit Capture Mode

### 12.6 PWM Mode

The HMS87C1X04B/08B/16B has a two high speed PWM (Pulse Width Modulation) functions which shared with Timer1 (Timer 3). In this document, it will be explained only PWM0.

In PWM mode, pin RB4/COMP0/PWM0 outputs up to a 10-bit resolution PWM output. This pin should be configure as a PWM output by setting "1" bit PWM00 in RBFUNC register. (PWM1 output by setting "1" bit PWM10 in RBFUNC)

The period of the PWM output is determined by the T1PPR (PWM0 Period Register) and PWM0HR[3:2] (bit3,2 of PWM0 High Register) and the duty of the PWM output is determined by the T1PDR (PWM0 Duty Register) and PWM0HR[1:0] (bit1,0 of PWM0 High Register).

The user writes the lower 8-bit period value to the T1PPR and the higher 2-bit period value to the PWM0HR[3:2]. And writes duty value to the T1PDR and the PWM0HR[1:0] same way.

The T1PDR is configure as a double buffering for glitchless PWM output. In Figure 12-10 , the duty data is transferred from the master to the slave when the period data matched to the counted value. (i.e. at the beginning of next duty cycle)

$$PWM\ Period = [PWM0HR[3:2]T1PPR] \times Source\ Clock$$

$$PWM\ Duty = [PWM0HR[1:0]T1PDR] \times Source\ Clock$$

The relation of frequency and resolution is in inverse proportion. Table 12-1 shows the relation of PWM frequency vs. resolution.

If it needed more higher frequency of PWM, it should be reduced resolution.

Resolution	Frequency		
	T1CK[1:0]=00(125nS)	T1CK[1:0]=01(250nS)	T1CK[1:0]=10(1uS)
10-bit	7.8KHz	3.9KHz	0.98KHZ
9-bit	15.6KHz	7.8KHz	1.95KHz
8-bit	31.2KHz	15.6KHz	3.90KHz
7-bit	62.5KHz	31.2KHz	7.81KHz

Table 12-1 PWM Frequency vs. Resolution at 8MHz

The bit POL of TM1 decides the polarity of duty cycle.

If the duty value is set same to the period value, the PWM output is determined by the bit POL (1: High, 0: Low). And if the duty value is set to "00<sub>H</sub>", the PWM output is determined by the bit POL (1: Low, 0: High).

It can be changed duty value when the PWM output. However the changed duty value is output after the current period is over and

it can be maintained the duty value at present output when changed only period value shown as Figure 12-12 . As it were, the absolute duty time is not changed in varying frequency. But the changed period value must greater than the duty value.

**Note:** If changing the Timer1 to PWM function, the timer should be stop and set to PWM mode (PWME = 1) firstly, and then set period and duty register value. When user writes register values while timer is in operation, these register could be set with certain values. If user sets the T1PPR, T1PDR register value with PWM mode being disabled, the T1PPR and T1PDR can not be accessed because these registers act as TDR1 and T1/CDR1 register in non-PWM mode.

```

Ex)      LDM TM1,#0010_0000b
         LDM T1PPR,#0EH
         LDM T1PDR,#05H
         LDM PWM0HR,#00H
         LDM RBFUNC,#0001_1100B
         LDM TM1,#1010_1011B
    
```

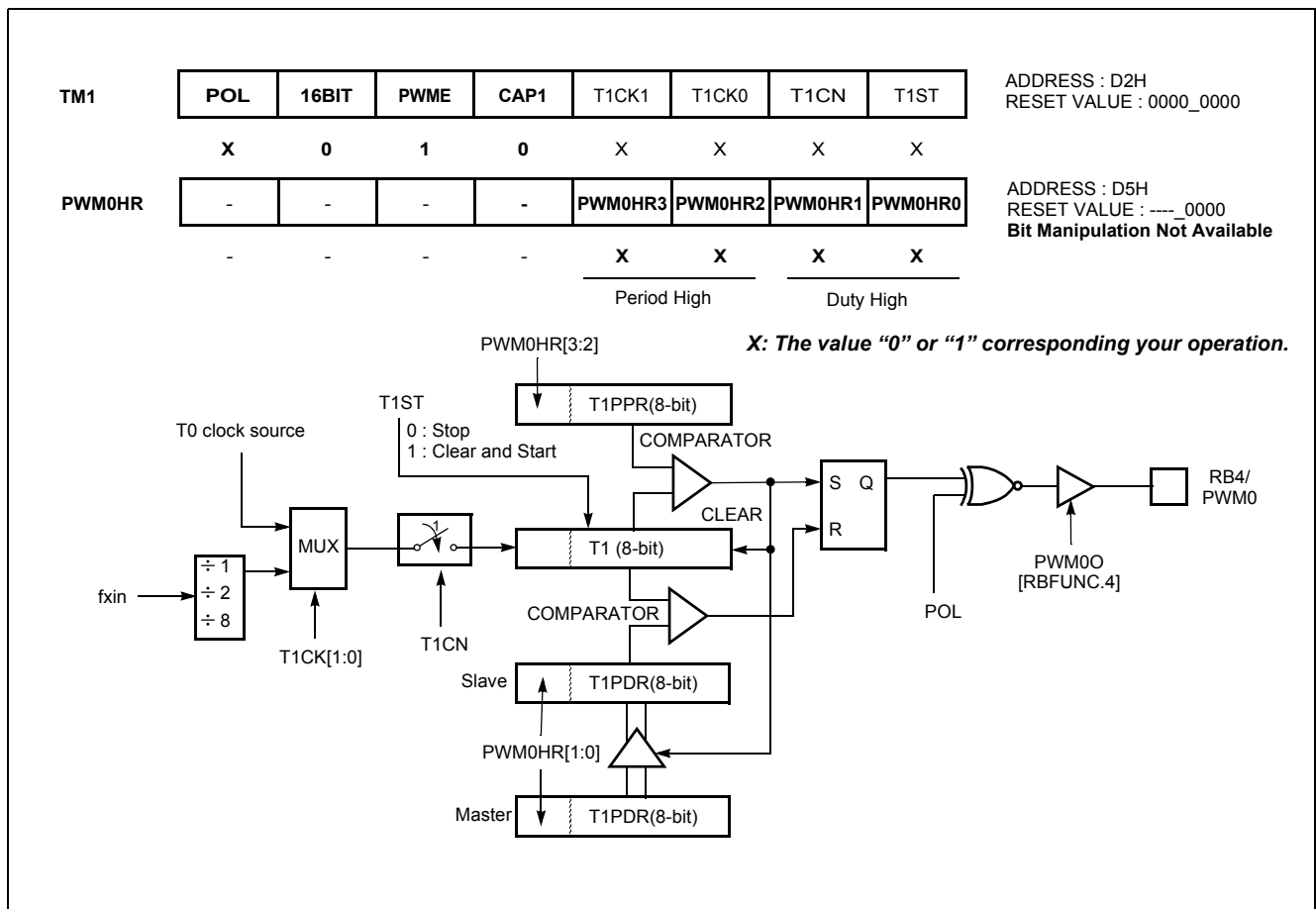

Figure 12-10 PWM Mode

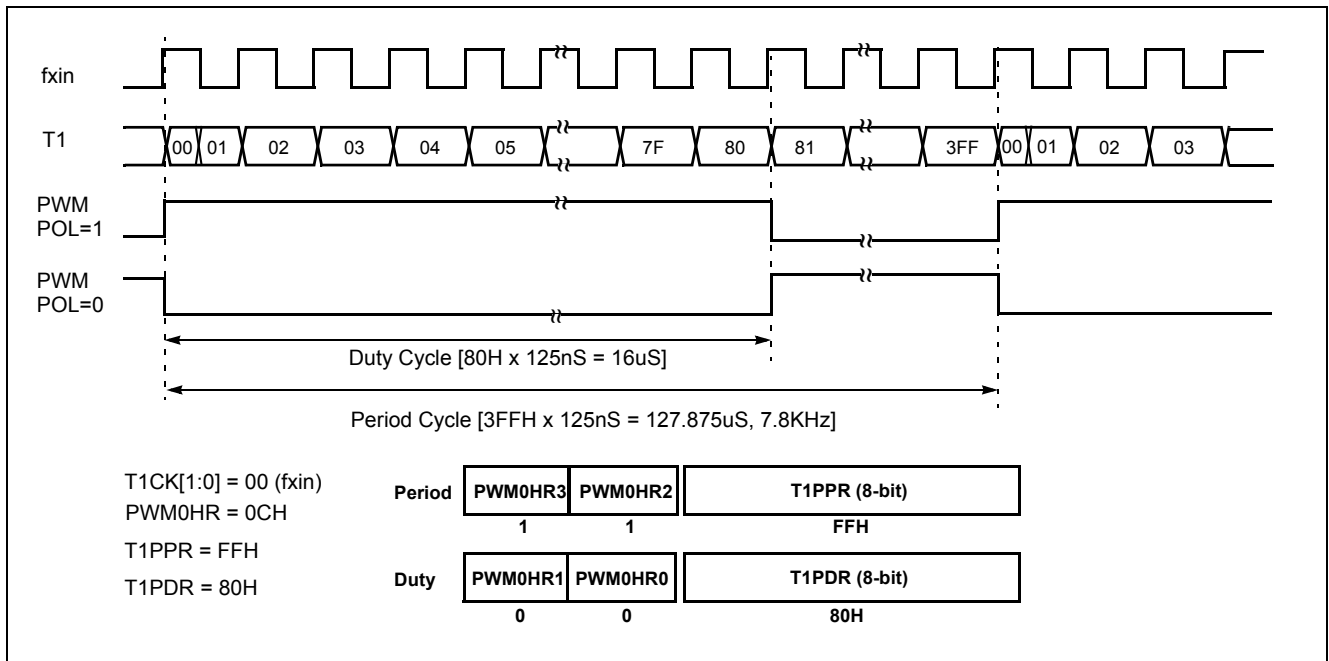

Figure 12-11 Example of PWM at 8MHz

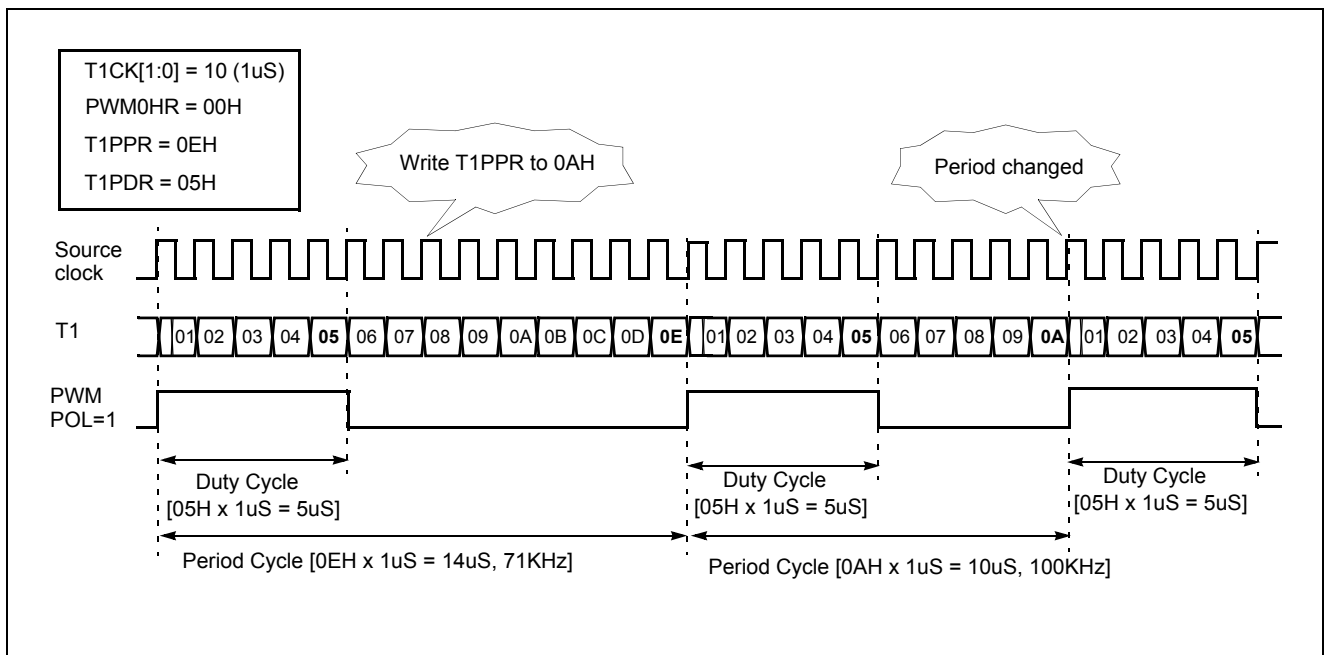

Figure 12-12 Example of Changing the Period in Absolute Duty Cycle (@8MHz)



### 13. Serial Peripheral Interface

The Serial Peripheral Interface (SPI) module is a serial interface useful for communicating with other peripheral of microcontrol-

ler devices. These peripheral devices may be serial EEPROMs, shift registers, display drivers, A/D converters, etc.

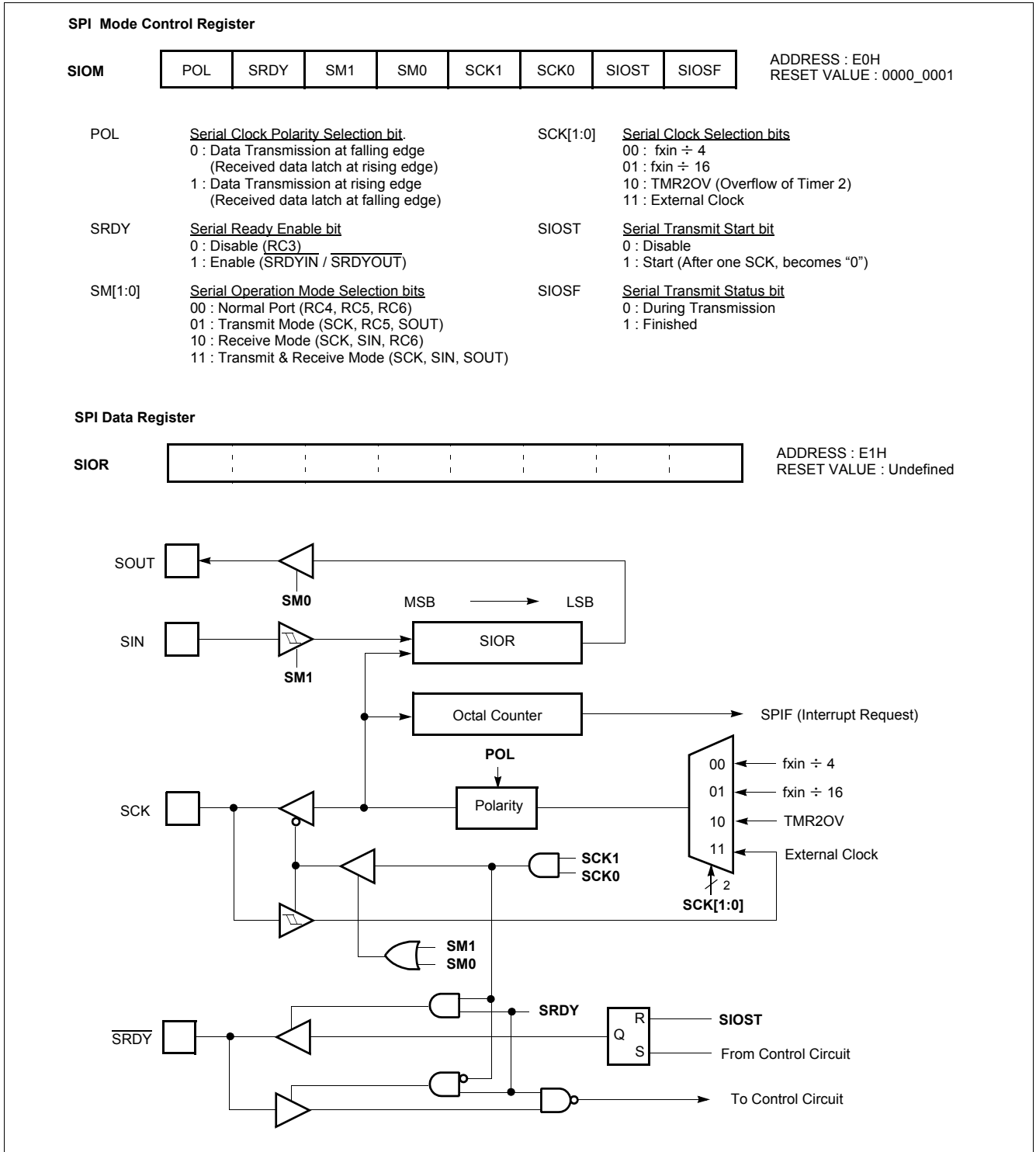

Figure 13-1 SPI Registers and Block Diagram

The SPI allows 8-bits of data to be synchronously transmitted and received. To accomplish communication, typically three pins are used:

- Serial Data In                    RC5/SIN
- Serial Data Out                RC6/SOUT
- Serial Clock                    RC4/SCK

In addition to those pins, a fourth pin may be used when in a master or a slave mode of operation:

- Serial Transfer Ready        RC3/SRDYIN/SRDYOUT

The serial data transfer operation mode is decided by setting the SM1 and SM0 of SPI Mode Control Register, and the transfer clock rate is decided by setting the SCK1 and SCK0 of SPI Mode Control Register as shown in Figure 13-1 . And the polarity of transfer clock is selected by setting the POL.

The bit SRDY is used for master / slave selection. If this bit is set to "1" and SCK[1:0] is set to "11", the controller is performed to slave controller. As it were, the port RC3 is served for  $\overline{\text{SRDY}}$ -OUT.

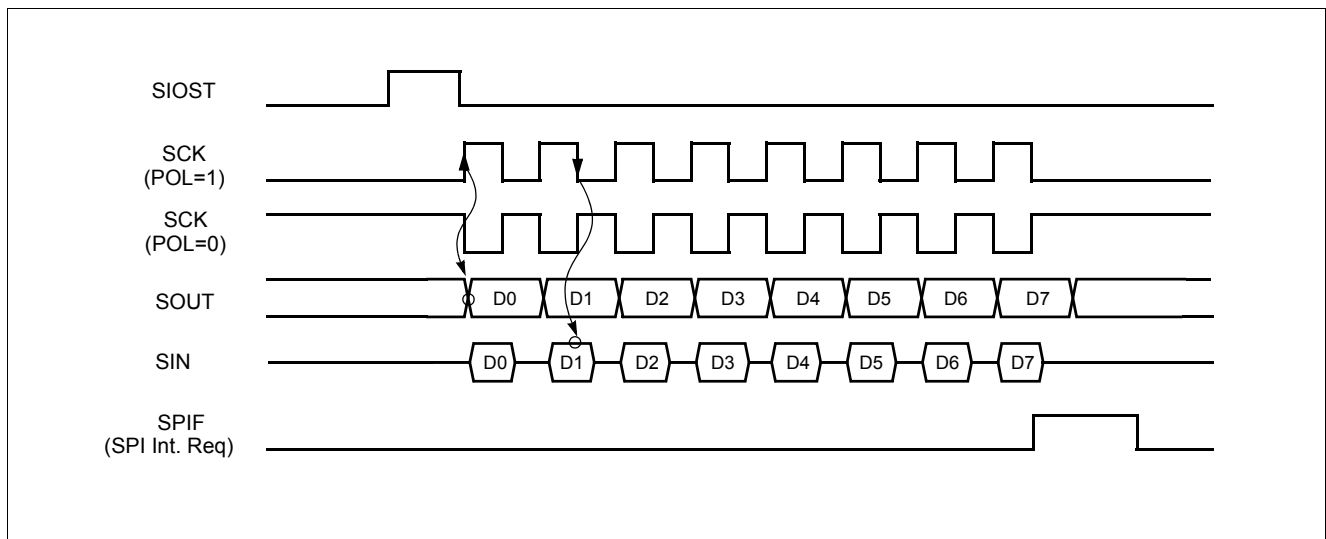

Figure 13-2 SPI Timing Diagram (without  $\overline{\text{SRDY}}$  control)

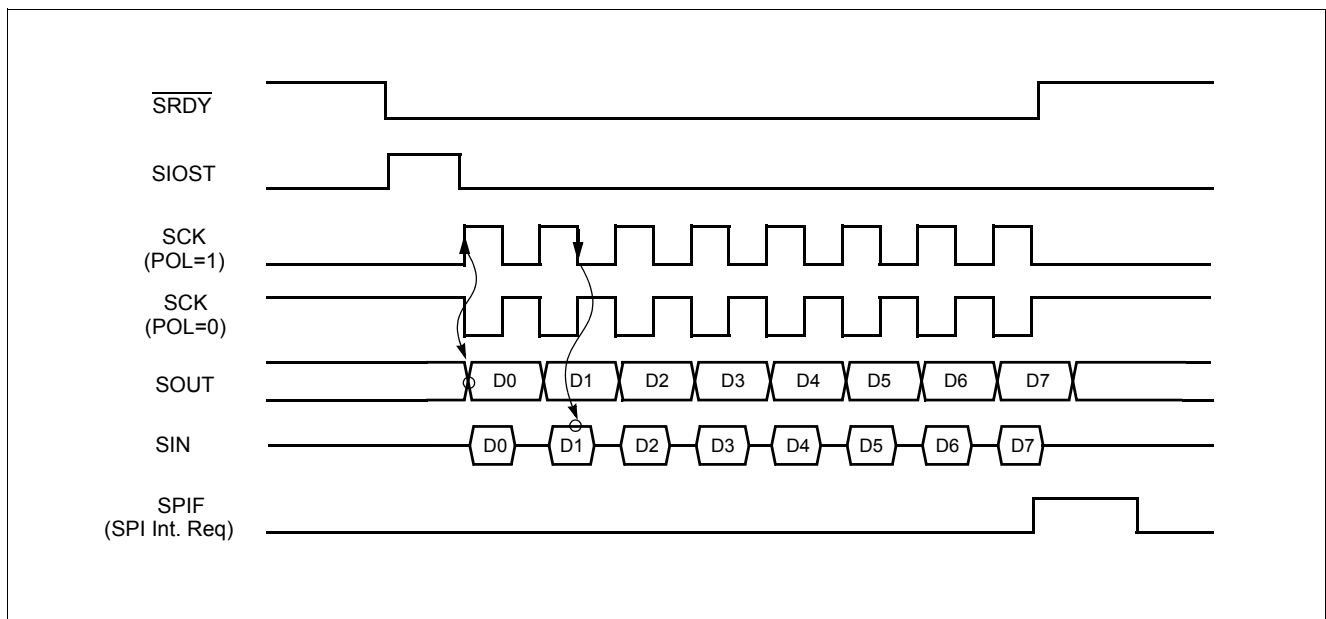

Figure 13-3 SPI Timing Diagram (with  $\overline{\text{SRDY}}$  control)

### 14. Buzzer Output function

The buzzer driver consists of 6-bit binary counter, the buzzer register BUR and the clock selector. It generates square-wave which is very wide range frequency (480 Hz~250 KHz at  $f_{in} = 4\text{ MHz}$ ) by user programmable counter.

Pin RB1 is assigned for output port of Buzzer driver by setting the bit BUZO of RBFUNC to "1".

The 6-bit buzzer counter is cleared and start the counting by writing signal to the register BUR. It is increased from 00H until it matches 6-bit register BUR.

Also, it is cleared by counter overflow and count up to output the square wave pulse of duty 50%.

The bit 0 to 5 of BUR determines output frequency for buzzer driving. Frequency calculation is following as shown below.

$$f_{BUZ}(Hz) = \frac{\text{Oscillator Frequency}}{2 \times \text{Prescaler Ratio} \times (BUR + 1)}$$

The bits BUCK1, BUCK0 of BUR selects the source clock from prescaler output.

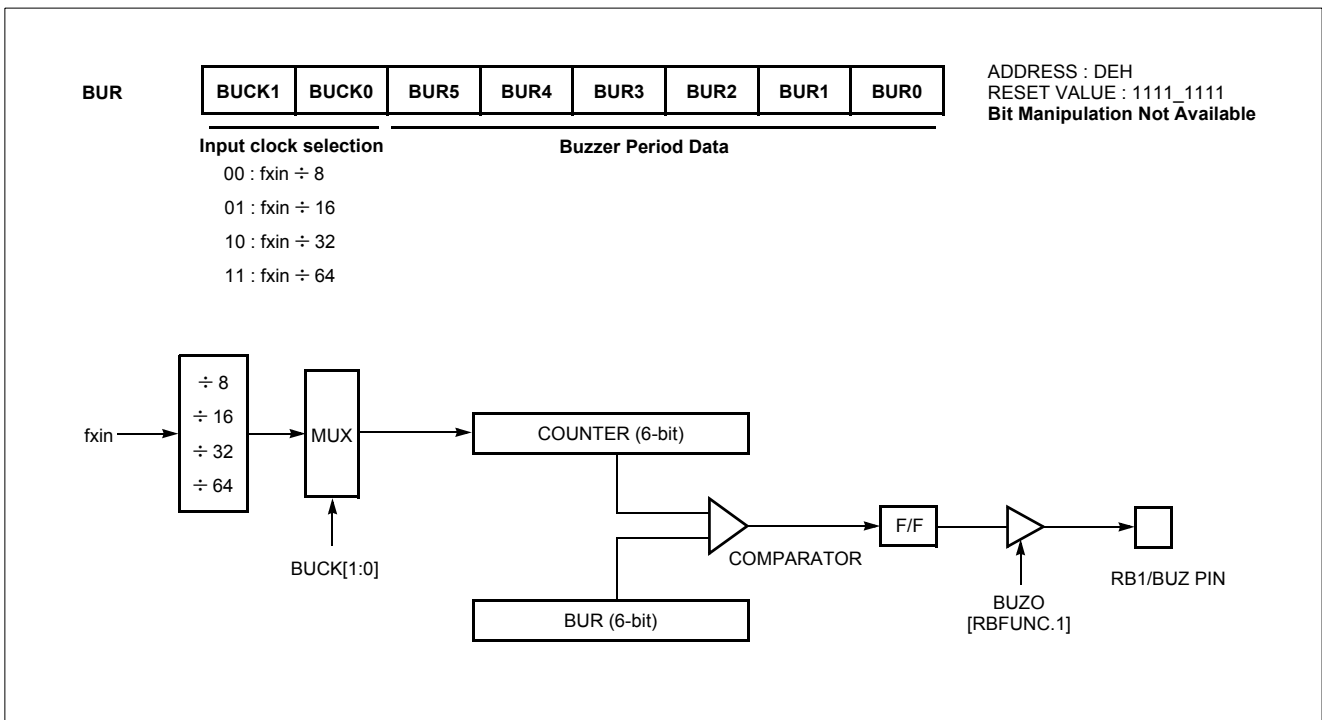

Figure 14-1 Buzzer Driver

### 15. ANALOG TO DIGITAL CONVERTER

The analog-to-digital converter (A/D) allows conversion of an analog input signal to a corresponding 8-bit digital value. The A/D module has eight analog inputs, which are multiplexed into one sample and hold. The output of the sample and hold is the input into the converter, which generates the result via successive approximation.

The analog reference voltage is selected to  $V_{DD}$  or  $AV_{ref}$  by setting of the bit  $AVREFS$  in  $RBFUNC$  register. If external analog reference  $AV_{ref}$  is selected, the bit  $ANSEL0$  should not be set to "1", because this pin is used to an analog reference of A/D converter.

The A/D module has two registers which are the control register  $ADCM$  and A/D result register  $ADCR$ . The  $ADCM$  register, shown in Figure 15-2, controls the operation of the A/D converter module. The port pins can be configure as analog inputs or digital I/O.

To use analog inputs, each port is assigned analog input port by setting the bit  $ANSEL[7:0]$  in  $RAFUNC$  register. And selected the corresponding channel to be converted by setting  $ADS[2:0]$ .

The processing of conversion start when the start bit  $ADST$  is set to "1". After one cycle, it is cleared by hardware. The register  $ADCR$  contains the results of the A/D conversion. When the conversion is completed, the result is loaded into the  $ADCR$ , the A/D conversion status bit  $ADSF$  is set to "1", and the A/D interrupt flag  $ADIF$  is set. The block diagram of the A/D module is shown in Figure 15-1. The A/D status bit,  $ADSF$  is set automatically when A/D conversion is completed, cleared when A/D conversion is in process. The conversion time takes maximum 10  $\mu s$  (at  $f_{xin}=8$  MHz).

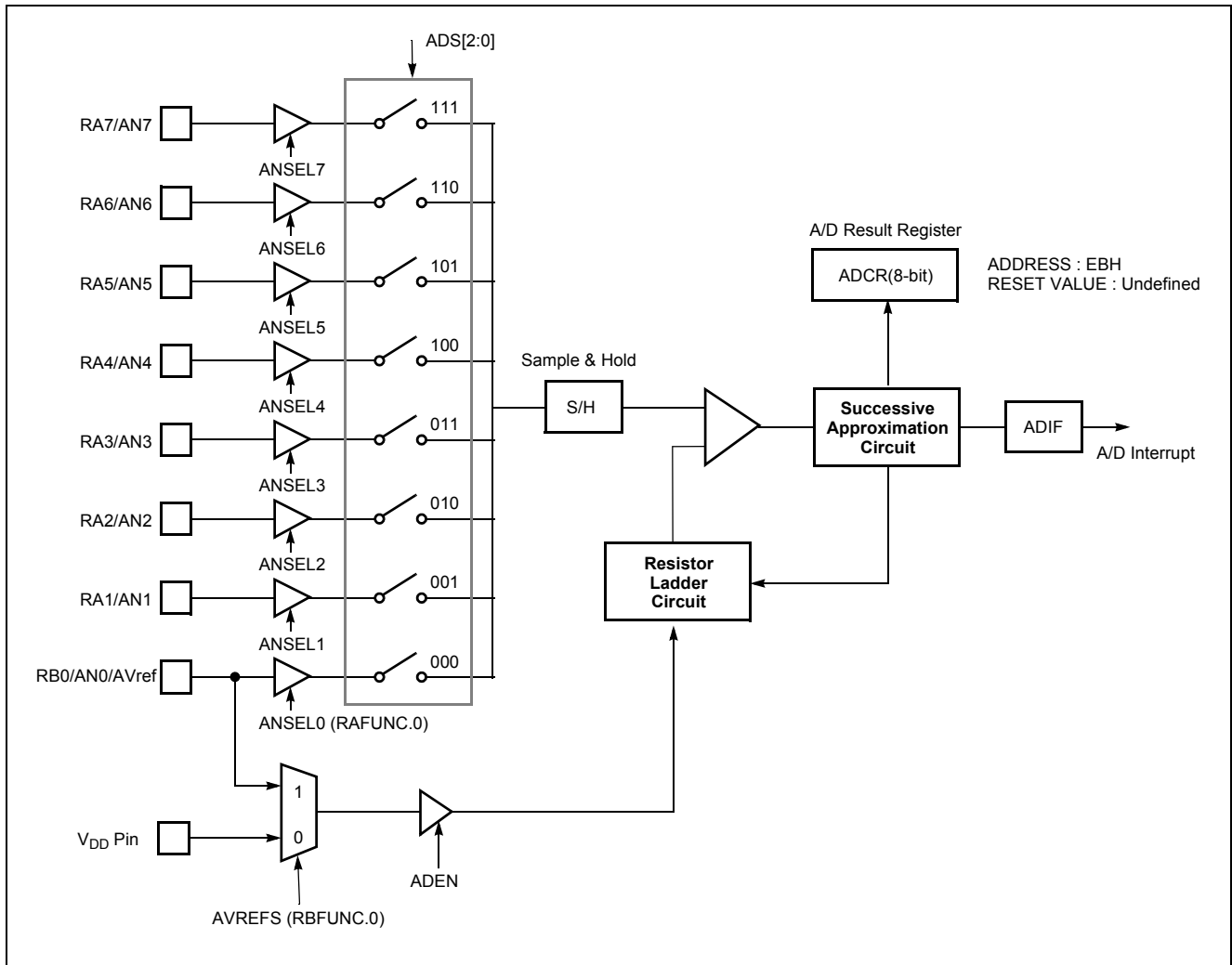

Figure 15-1 A/D Converter Block Diagram

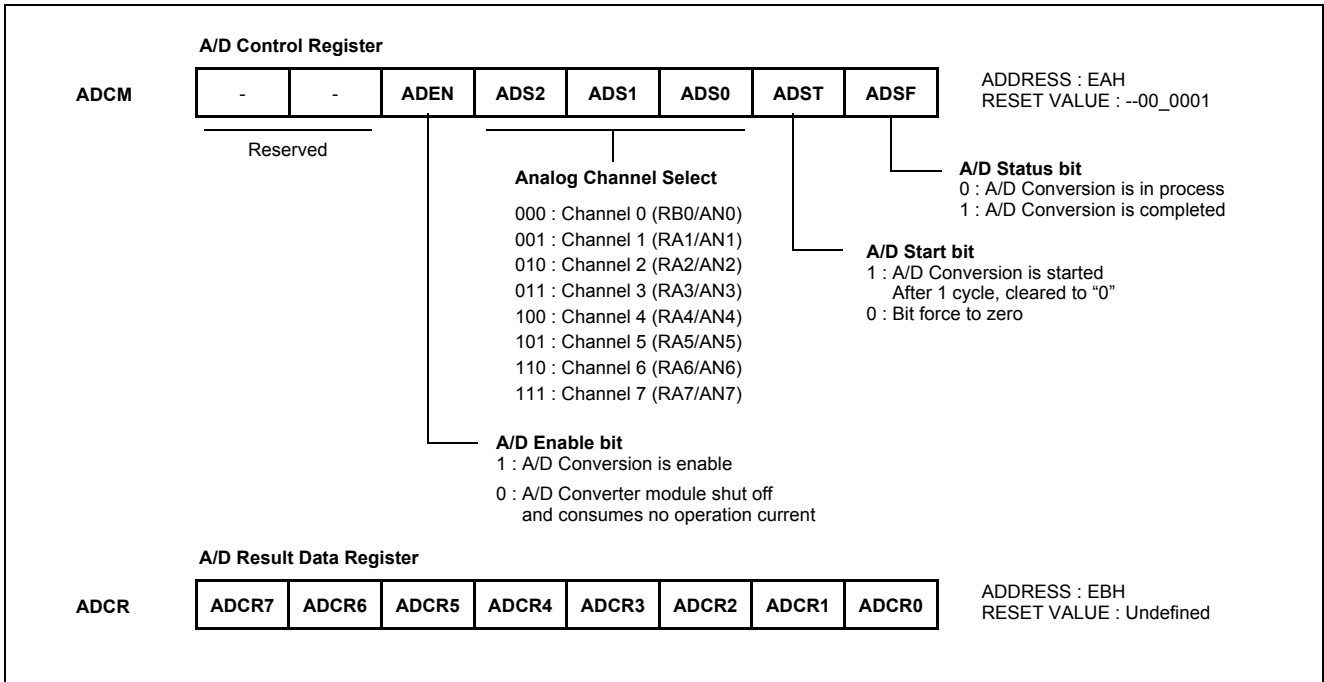

Figure 15-2 A/D Converter Registers

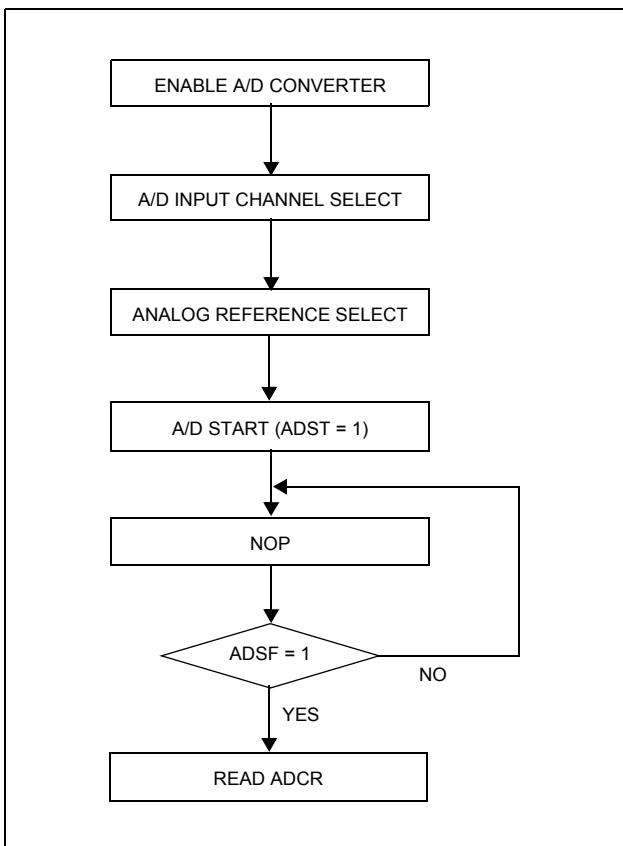

Figure 15-3 A/D Converter Operation Flow

**A/D Converter Cautions**

(1) Input range of AN0 to AN7

The input voltage of AN0 to AN7 should be within the specification range. In particular, if a voltage above VDD (or AVref) or below Vss is input (even if within the absolute maximum rating range), the conversion value for that channel can not be determinate. The conversion values of the other channels may also be affected.

(2) Noise countermeasures

In order to maintain 8-bit resolution, attention must be paid to noise on pins AVref (or VDD) and AN0 to AN7. Since the effect increases in proportion to the output impedance of the analog input source, it is recommended that a capacitor be connected externally as shown in Figure 15-4 in order to reduce noise.

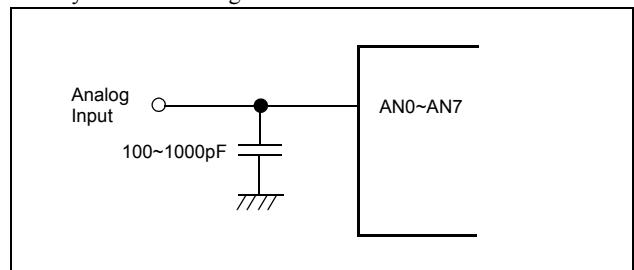

Figure 15-4 Analog Input Pin Connecting Capacitor

(3) Pins AN0/RB0 and AN1/RA1 to AN7/RA7

The analog input pins AN0 to AN7 also function as input/output

port (PORT RA and RB0) pins. When A/D conversion is performed with any of pins AN0 to AN7 selected, be sure not to execute a PORT input instruction while conversion is in progress, as this may reduce the conversion resolution.

Also, if digital pulses are applied to a pin adjacent to the pin in the process of A/D conversion, the expected A/D conversion value may not be obtainable due to coupling noise. Therefore, avoid applying pulses to pins adjacent to the pin undergoing A/D conversion.

#### (4) AVref pin input impedance

A series resistor string of approximately 10K $\Omega$  is connected between the AVref pin and the Vss pin.

Therefore, if the output impedance of the reference voltage source is high, this will result in parallel connection to the series resistor string between the AVref pin and the Vss pin, and there will be a large reference voltage error.

### 16. INTERRUPTS

The HMS87C1X04B/08B/16B interrupt circuits consist of Interrupt enable register (IENH, IENL), Interrupt request flags of IRQH, IRQL, Interrupt Edge Selection Register (IEDS), priority circuit and Master enable flag("I" flag of PSW). The configuration of interrupt circuit is shown in Figure 16-1 and Interrupt priority is shown in Table 16-1 .

The External Interrupts INT0, INT1, INT2 and INT3 can each be transition-activated (1-to-0, 0-to-1 and both transition).

The flags that actually generate these interrupts are bit INT0IF, INT1IF, INT2IF and INT3IF in Register IRQH. When an external interrupt is generated, the flag that generated it is cleared by

the hardware when the service routine is vectored to only if the interrupt was transition-activated.

The Timer 0, Timer 1, Timer 2 and Timer 3 Interrupts are generated by T0IF, T1IF, T2IF and T3IF, which are set by a match in their respective timer/counter register. The AD converter Interrupt is generated by ADIF which is set by finishing the analog to digital conversion. The Watch dog timer Interrupt is generated by WDTIF which is set by a match in Watch dog timer register (when the bit WDTON is set to "0"). The Basic Interval Timer Interrupt is generated by BITIF which is set by a overflowing of the Basic Interval Timer Register(BITR).

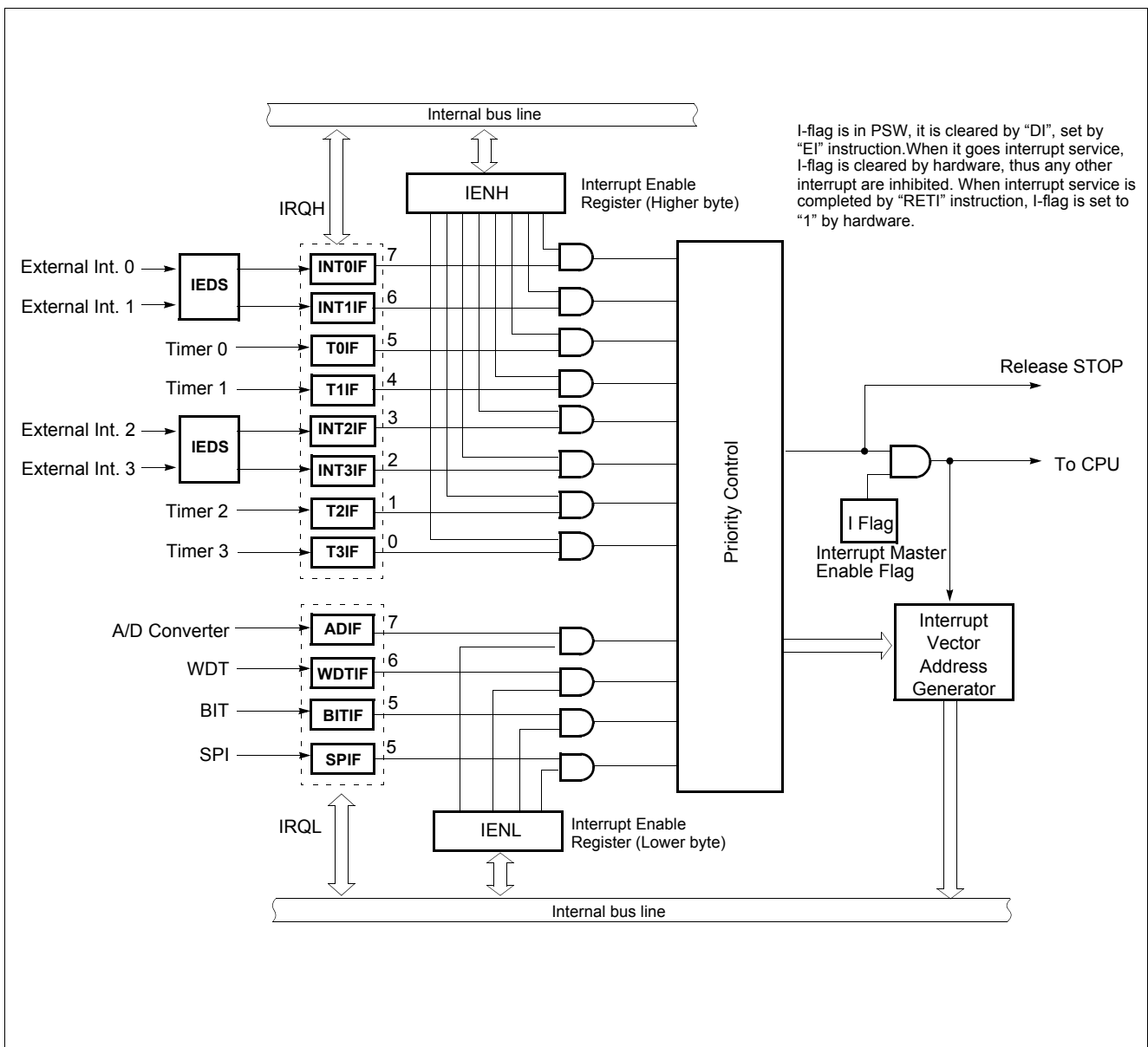

Figure 16-1 Block Diagram of Interrupt Function

The interrupts are controlled by the interrupt master enable flag I-flag (bit 2 of PSW), the interrupt enable register (IENH, IENL) and the interrupt request flags (in IRQH, IRQL) except Power-on reset and software BRK interrupt.

Interrupt enable registers are shown in Figure 16-2 . These registers are composed of interrupt enable flags of each interrupt source, these flags determines whether an interrupt will be accepted or not. When enable flag is “0”, a corresponding interrupt source is prohibited. Note that PSW contains also a master enable bit, I-flag, which disables all interrupts at once.

Reset/Interrupt	Symbol	Priority	Vector Addr.
Hardware Reset	RESET	-	FFFE <sub>H</sub>
External Interrupt 0	INT0	1	FFFA <sub>H</sub>
External Interrupt 1	INT1	2	FFF8 <sub>H</sub>
Timer 0	Timer 0	3	FFF6 <sub>H</sub>
Timer 1	Timer 1	4	FFF4 <sub>H</sub>
External Interrupt 2	INT2	5	FFF2 <sub>H</sub>
External Interrupt 3	INT3	6	FFF0 <sub>H</sub>
Timer 2	Timer 2	7	FFEE <sub>H</sub>
Timer 3	Timer 3	8	FFEC <sub>H</sub>
A/D Converter	A/D C	9	FFEA <sub>H</sub>
Watch Dog Timer	WDT	10	FFE8 <sub>H</sub>
Basic Interval Timer	BIT	11	FFE6 <sub>H</sub>
Serial Interface	SPI	12	FFE4 <sub>H</sub>

Table 16-1 Interrupt Priority

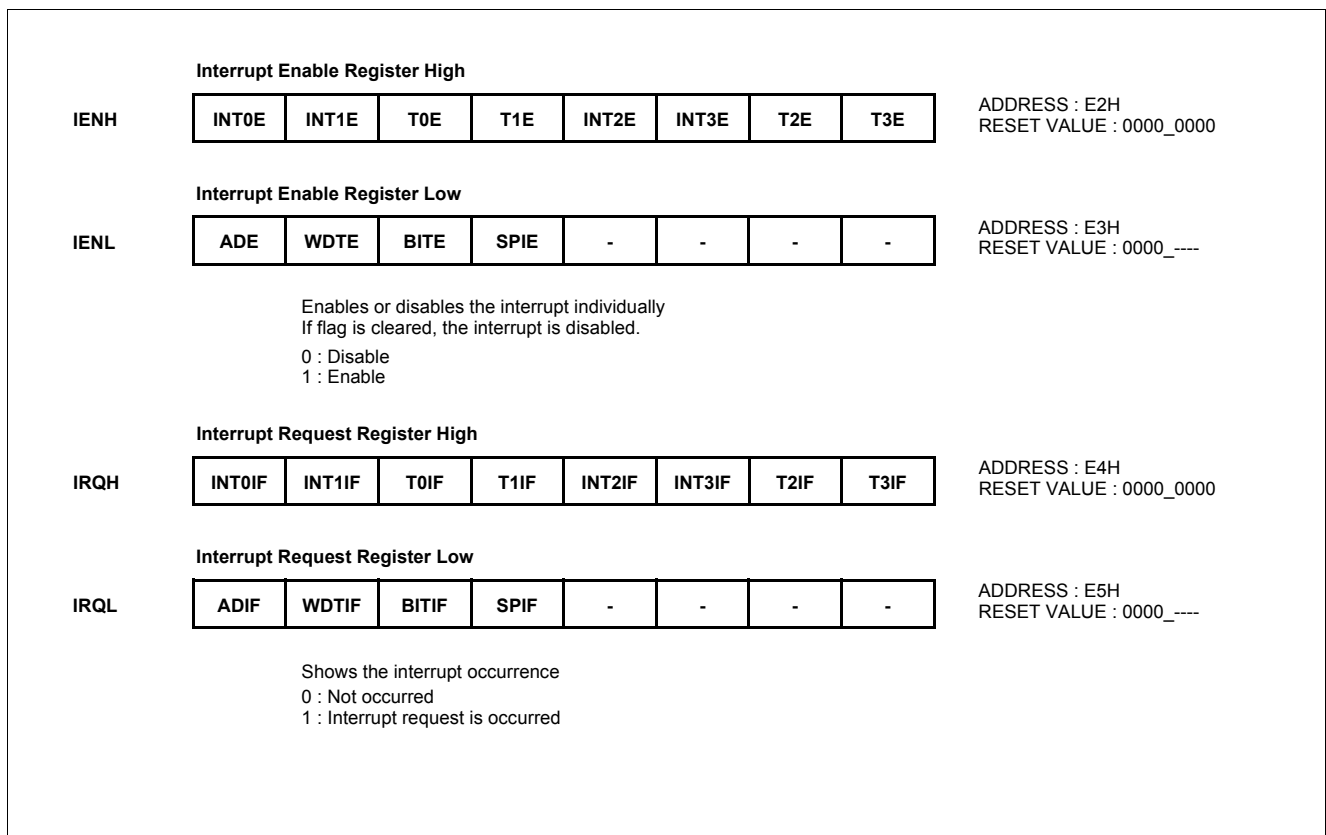

Figure 16-2 Interrupt Enable Registers and Interrupt Request Registers

When an interrupt is occurred, the I-flag is cleared and disable any further interrupt, the return address and PSW are pushed into the stack and the PC is vectored to. Once in the interrupt service routine the source(s) of the interrupt can be determined by polling the interrupt request flag bits.

The interrupt request flag bit(s) must be cleared by software before re-enabling interrupts to avoid recursive interrupts. The Interrupt Request flags are able to be read and written.



### 16.1 Interrupt Sequence

An interrupt request is held until the interrupt is accepted or the interrupt latch is cleared to “0” by a reset or an instruction. Interrupt acceptance sequence requires  $8 f_{OSC}$  ( $2 \mu s$  at  $f_{XIN}=4MHz$ ) after the completion of the current instruction execution. The interrupt service task is terminated upon execution of an interrupt return instruction [RETI].

#### Interrupt acceptance

1. The interrupt master enable flag (I-flag) is cleared to “0” to temporarily disable the acceptance of any following maskable interrupts. When a non-maskable interrupt is accepted, the acceptance of any following interrupts is temporarily disabled.

2. Interrupt request flag for the interrupt source accepted is cleared to “0”.
3. The contents of the program counter (return address) and the program status word are saved (pushed) onto the stack area. The stack pointer decreases 3 times.
4. The entry address of the interrupt service program is read from the vector table address and the entry address is loaded to the program counter.
5. The instruction stored at the entry address of the interrupt service program is executed.

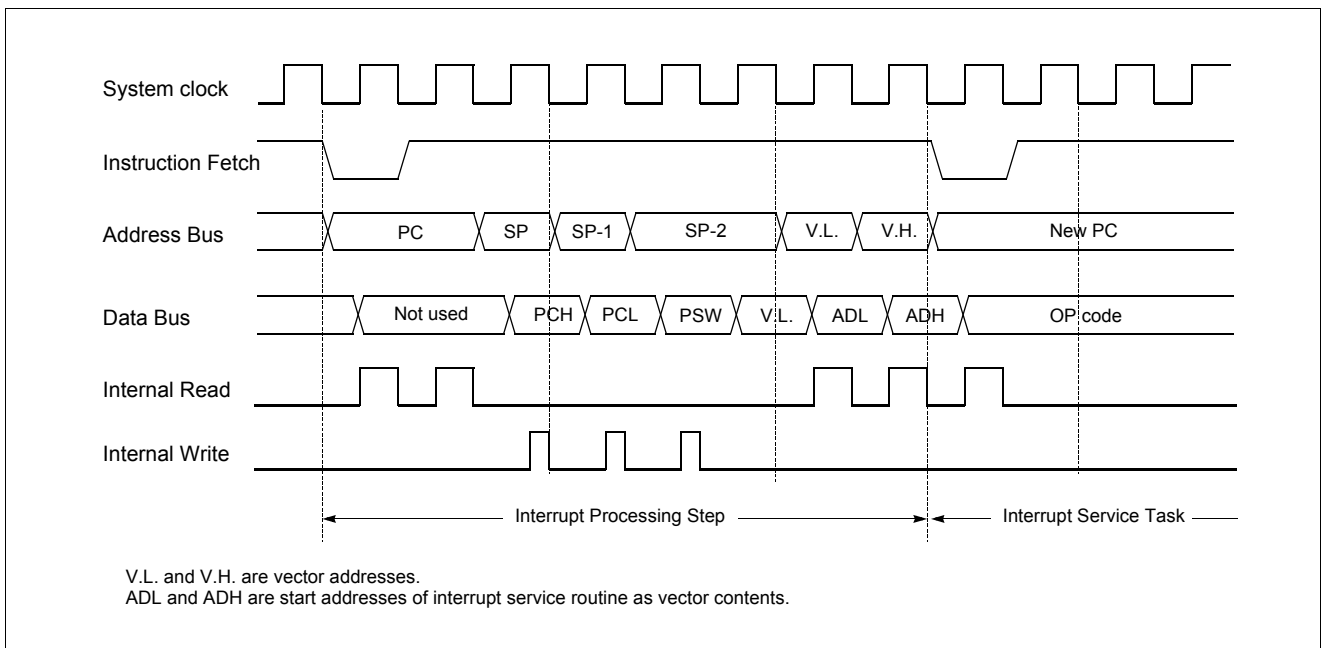
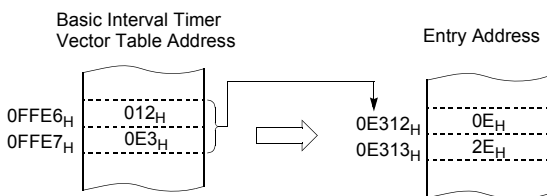

Figure 16-3 Timing chart of Interrupt Acceptance and Interrupt Return Instruction



Correspondence between vector table address for BIT interrupt and the entry address of the interrupt service program.

An interrupt request is not accepted until the I-flag is set to “1” even if a requested interrupt has higher priority than that of the current interrupt being serviced.

When nested interrupt service is required, the I-flag should be set to “1” by “EI” instruction in the interrupt service program. In this case, acceptable interrupt sources are selectively enabled by the individual interrupt enable flags.

#### Saving/Restoring General-purpose Register

During interrupt acceptance processing, the program counter and the program status word are automatically saved on the stack, but accumulator and other registers are not saved itself. These registers are saved by the software if necessary. Also, when multiple interrupt services are nested, it is necessary to avoid using the same data memory area for saving registers.

The following method is used to save/restore the general-purpose registers.

Example: Register save using push and pop instructions

```

INTxx:  PUSH   A      ;SAVE ACC.
        PUSH   X      ;SAVE X REG.
        PUSH   Y      ;SAVE Y REG.

        [interrupt processing]

        POP    Y      ;RESTORE Y REG.
        POP    X      ;RESTORE X REG.
        POP    A      ;RESTORE ACC.
        RETI         ;RETURN
    
```

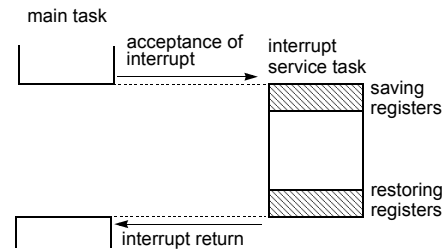

General-purpose register save/restore using push and pop instructions;

### 16.2 BRK Interrupt

Software interrupt can be invoked by BRK instruction, which has the lowest priority order.

Interrupt vector address of BRK is shared with the vector of TCALL 0 (Refer to Program Memory Section). When BRK interrupt is generated, B-flag of PSW is set to distinguish BRK from TCALL 0.

Each processing step is determined by B-flag as shown in Figure 16-4 .

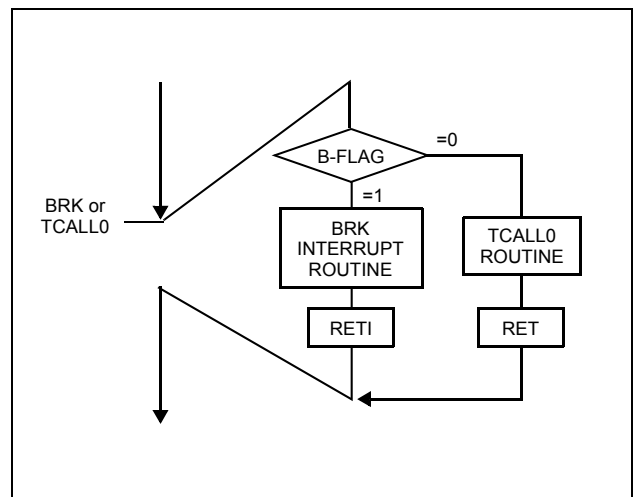

Figure 16-4 Execution of BRK/TCALL0

### 16.3 Multi Interrupt

If two requests of different priority levels are received simultaneously, the request of higher priority level is serviced. If requests of the interrupt are received at the same time simultaneously, an internal polling sequence determines by hardware which request is serviced.

However, multiple processing through software for special features is possible. Generally when an interrupt is accepted, the I-flag is cleared to disable any further interrupt. But as user sets I-flag in interrupt routine, some further interrupt can be serviced even if certain interrupt is in progress.

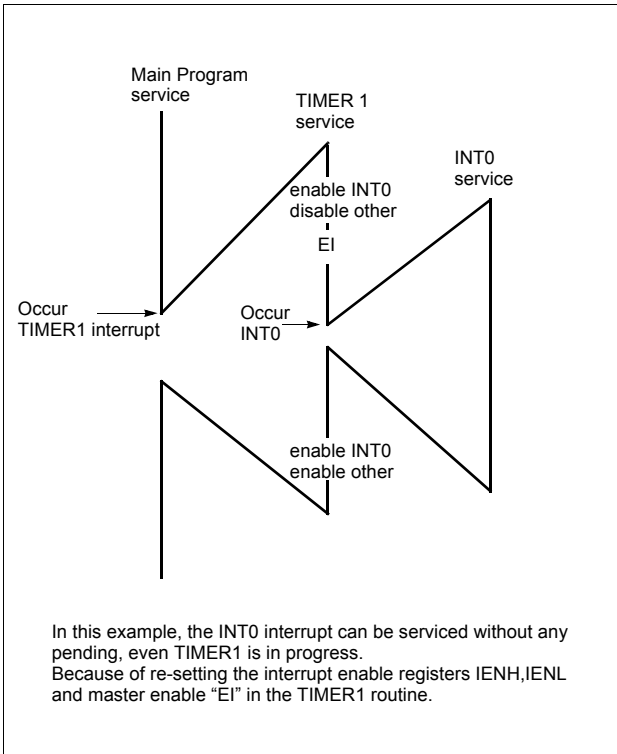

Figure 16-5 Execution of Multi Interrupt

Example: Even though Timer1 interrupt is in progress, INT0 interrupt serviced without any suspend.

```

TIMER1:  PUSH  A
         PUSH  X
         PUSH  Y
         LDM  IENH, #80H ; Enable INT0 only
         LDM  IENL, #0   ; Disable other
         EI    ; Enable Interrupt
         :
         :
         :
         :
         :
         LDM  IENH, #0FFH ; Enable all interrupts
         LDM  IENL, #0F0H
         POP  Y
         POP  X
         POP  A
         RETI
    
```

### 16.4 External Interrupt

The external interrupt on INT0, INT1, INT2 and INT3 pins are edge triggered depending on the edge selection register IEDS (address 0E6<sub>H</sub>) as shown in Figure 16-6 .

The edge detection of external interrupt has three transition activated mode: rising edge, falling edge, and both edge.

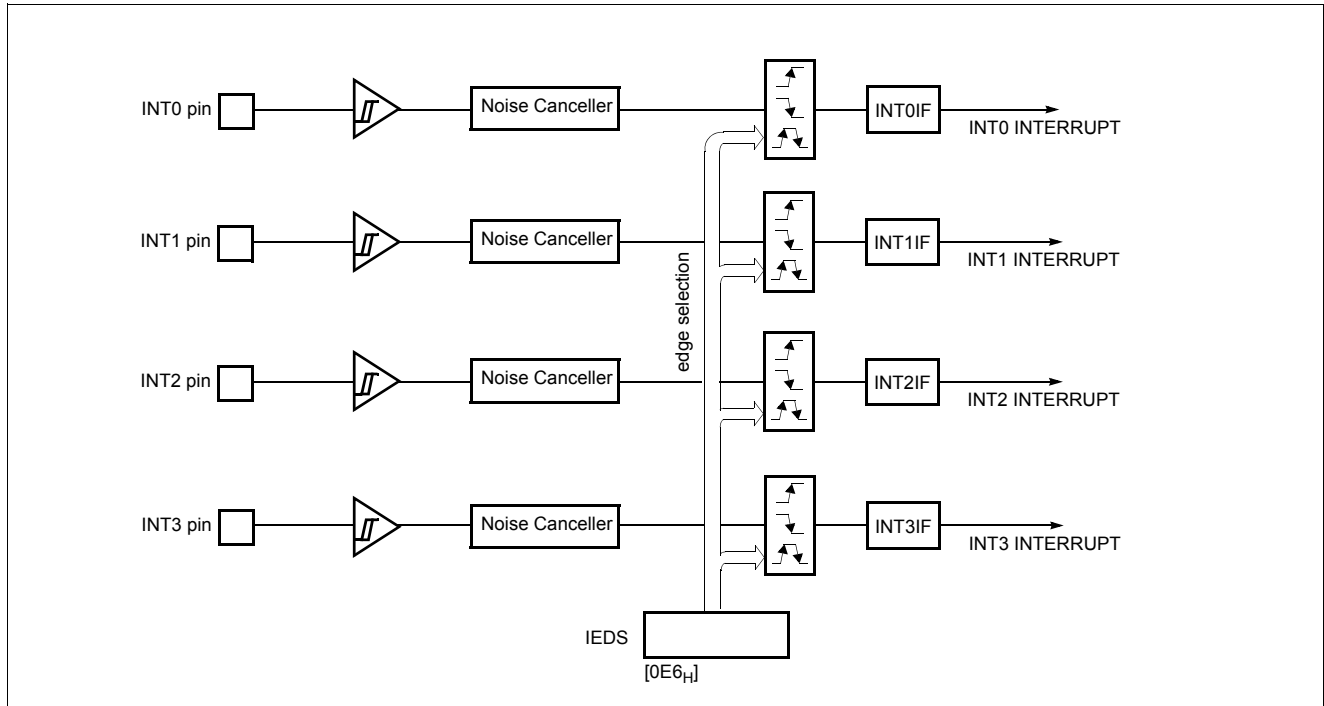
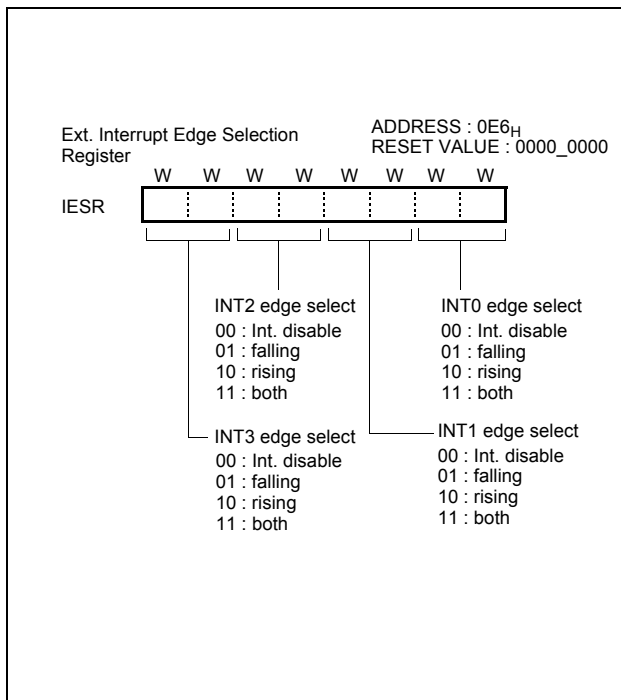

Figure 16-6 External Interrupt Block Diagram



Example: To use as an INT0 and INT2

```

:
:
;**** Set port as an input port RB2,RD0
LDM RBIO,#1111_1011B
LDM RDIO,#1111_1110B
;
;**** Set port as an interrupt port
LDM RBFUNC,#04H
LDM RDFUNC,#01H
;
;**** Set Falling-edge Detection
LDM IEDS,#0001_0001B
:
:
:

```

#### Response Time

The INT0, INT1,INT2 and INT3 edge are latched into INTOIF, INT1IF, INT2IF and INT3IF at every machine cycle. The values are not actually polled by the circuitry until the next machine cycle. If a request is active and conditions are right for it to be acknowledged, a hardware subroutine call to the requested service routine will be the next instruction to be executed. The DIV itself takes twelve cycles. Thus, a minimum of twelve complete machine cycles elapse between activation of an external interrupt request and the beginning of execution of the first instruction of the service routine.

shows interrupt response timings.

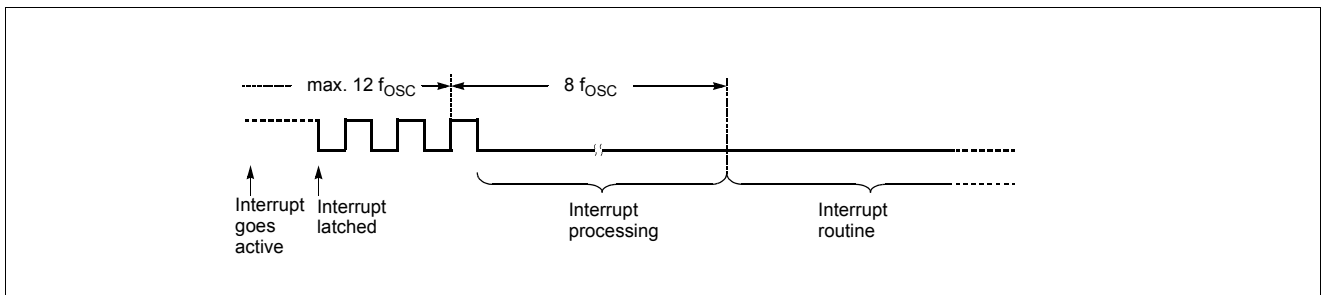

Figure 16-7 Interrupt Response Timing Diagram

### 17. WATCHDOG TIMER

The purpose of the watchdog timer is to detect the malfunction (runaway) of program due to external noise or other causes and return the operation to the normal condition.

The watchdog timer has two types of clock source.

The first type is an on-chip RC oscillator which does not require any external components. This RC oscillator is separate from the external oscillator of the Xin pin. It means that the watchdog timer will run, even if the clock on the Xin pin of the device has been stopped, for example, by entering the STOP mode.

The other type is a prescaled system clock.

The watchdog timer consists of 7-bit binary counter and the watchdog timer data register. When the value of 7-bit binary counter is equal to the lower 7 bits of WDTR, the interrupt request flag is generated. This can be used as WDT interrupt or reset the CPU in accordance with the bit WDTON.

**Note:** Because the watchdog timer counter is enabled after clearing Basic Interval Timer, after the bit WDTON set to "1", maximum error of timer is depend on prescaler ratio of Basic Interval Timer.

The 7-bit binary counter is cleared by setting WDTCL(bit7 of

WDTR) and the WDTCL is cleared automatically after 1 machine cycle.

The RC oscillated watchdog timer is activated by setting the bit RCWDT as shown below.

```

:
LDM    CKCTLR, #3FH; enable the RC-osc WDT
LDM    WDTR, #0FFH; set the WDT period
STOP   ; enter the STOP mode
NOP
NOP    ; RC-osc WDT running
:
    
```

The RC oscillation period is vary with temperature, V<sub>DD</sub> and process variations from part to part (approximately, 40~120uS). The following equation shows the RC oscillated watchdog timer time-out.

$$T_{RCWDT} = CLK_{RC} \times 2^8 \times [WDTR.6 \sim 0] + (CLK_{RC} \times 2^8) / 2$$

where,  $CLK_{RC} = 40 \sim 120 \mu S$

In addition, this watchdog timer can be used as a simple 7-bit timer by interrupt WDTIF. The interval of watchdog timer interrupt is decided by Basic Interval Timer. Interval equation is as below.

$$T_{WDT} = [WDTR.6 \sim 0] \times \text{Interval of BIT}$$

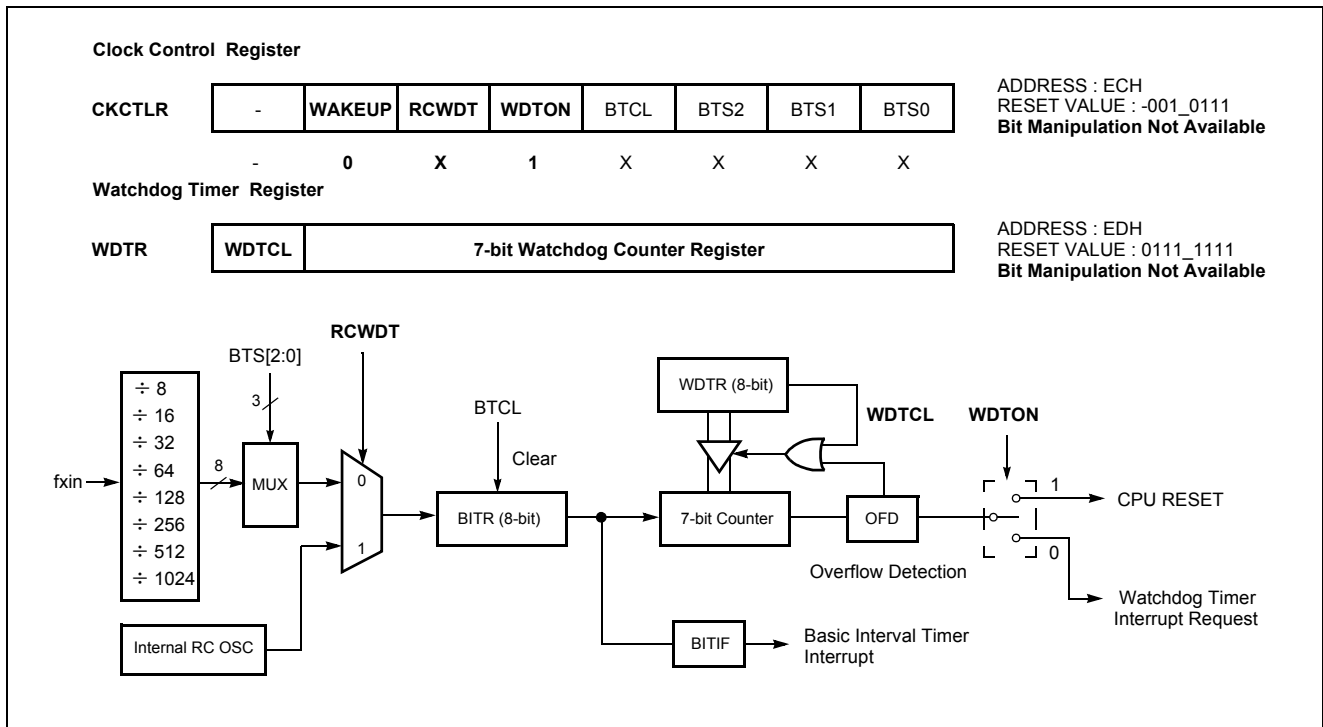

Figure 17-1 Block Diagram of Watchdog Timer

## 18. Power Saving Mode

For applications where power consumption is a critical factor, this device provides two kinds of power saving functions, STOP mode and Wake-up Timer mode.

The power saving function is activated by execution of STOP in-

struction after setting the corresponding status (WAKEUP) of CKCTLR.

Table 18-1 shows the status of each Power Saving Mode.

Peripheral	STOP	Wake-up Timer
RAM	Retain	Retain
Control Registers	Retain	Retain
I/O Ports	Retain	Retain
CPU	Stop	Stop
Timer0, Timer2	Stop	Operation
Oscillation	Stop	Oscillation
Prescaler	Stop	÷ 2048 only
Entering Condition [WAKEUP]	0	1
Release Sources	RESET, RCWDT, INT0~3, EC0~1, SPI	RESET, RCWDT, INT0~3, EC0~1, SPI, TIMER0, TIMER2

Table 18-1 Power Saving Mode

### 18.1 Stop Mode

In the Stop mode, the on-chip oscillator is stopped. With the clock frozen, all functions are stopped, but the on-chip RAM and Control registers are held. The port pins out the values held by their respective port data register, port direction registers. Oscillator stops and the systems internal operations are all held up.

- The states of the RAM, registers, and latches valid immediately before the system is put in the STOP state are all held.
- The program counter stop the address of the instruction to be executed after the instruction “STOP” which starts the STOP operating mode.

**The Stop mode is activated by execution of STOP instruction after clearing the bit WAKEUP of CKCTLR to “0”. (This register should be written by byte operation. If this register is set by bit manipulation instruction, for example “set1” or “clr1” instruction, it may be undesired operation)**

In the Stop mode of operation,  $V_{DD}$  can be reduced to minimize power consumption. Care must be taken, however, to ensure that  $V_{DD}$  is not reduced before the Stop mode is invoked, and that  $V_{DD}$  is restored to its normal operating level, before the Stop mode is terminated.

The reset should not be activated before  $V_{DD}$  is restored to its normal operating level, and must be held active long enough to allow the oscillator to restart and stabilize.

**Note:** After STOP instruction, at least two or more NOP instruction should be written

```
Ex)      LDM    CKCTLR,#0000_1110B
          STOP
          NOP
          NOP
```

In the STOP operation, the dissipation of the power associated with the oscillator and the internal hardware is lowered; however, the power dissipation associated with the pin interface (depending on the external circuitry and program) is not directly determined by the hardware operation of the STOP feature. This point should be little current flows when the input level is stable at the power voltage level ( $V_{DD}/V_{SS}$ ); however, when the input level gets higher than the power voltage level (by approximately 0.3 to 0.5V), a current begins to flow. Therefore, if cutting off the output transistor at an I/O port puts the pin signal into the high-impedance state, a current flow across the ports input transistor, requiring to fix the level by pull-up or other means.

**Release the STOP mode**

The exit from STOP mode is hardware reset or external interrupt. Reset re-defines all the Control registers but does not change the on-chip RAM. External interrupts allow both on-chip RAM and Control registers to retain their values. If I-flag = 1, the normal interrupt response takes place. If I-flag = 0, the chip will resume execution starting with the instruction following the STOP instruction. It will not vector to interrupt service routine. (refer to Figure 18-1 )

By reset, exit from Stop mode is shown in Figure 18-3 .When exit from Stop mode by external interrupt, enough oscillation stabilization time is required to normal operation. Figure 18-2 shows the timing diagram. When release the Stop mode, the Basic interval timer is activated on wake-up. It is increased from 00<sub>H</sub> until FF<sub>H</sub> . The count overflow is set to start normal operation. Therefore, before STOP instruction, user must be set its relevant pre-scaler divide ratio to have long enough time (more than 20msec). This guarantees that oscillator has started and stabilized..

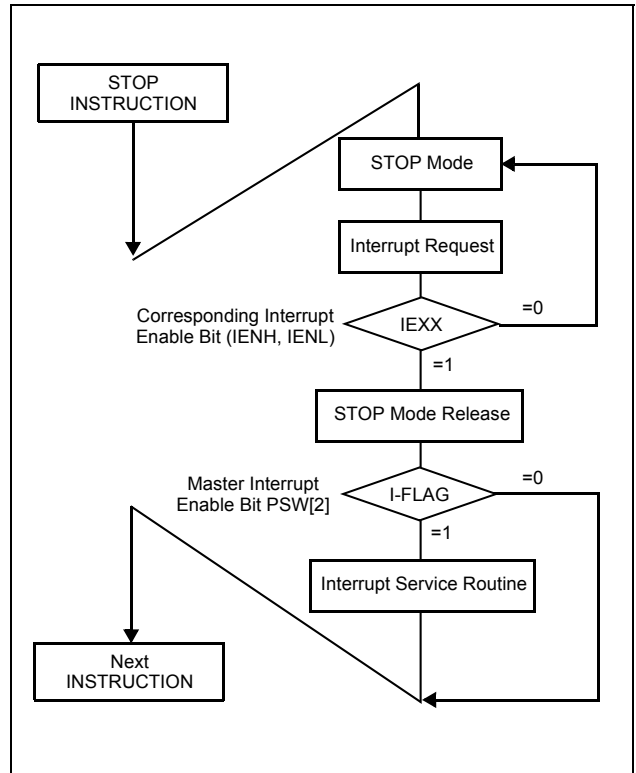

Figure 18-1 STOP Releasing Flow by Interrupts

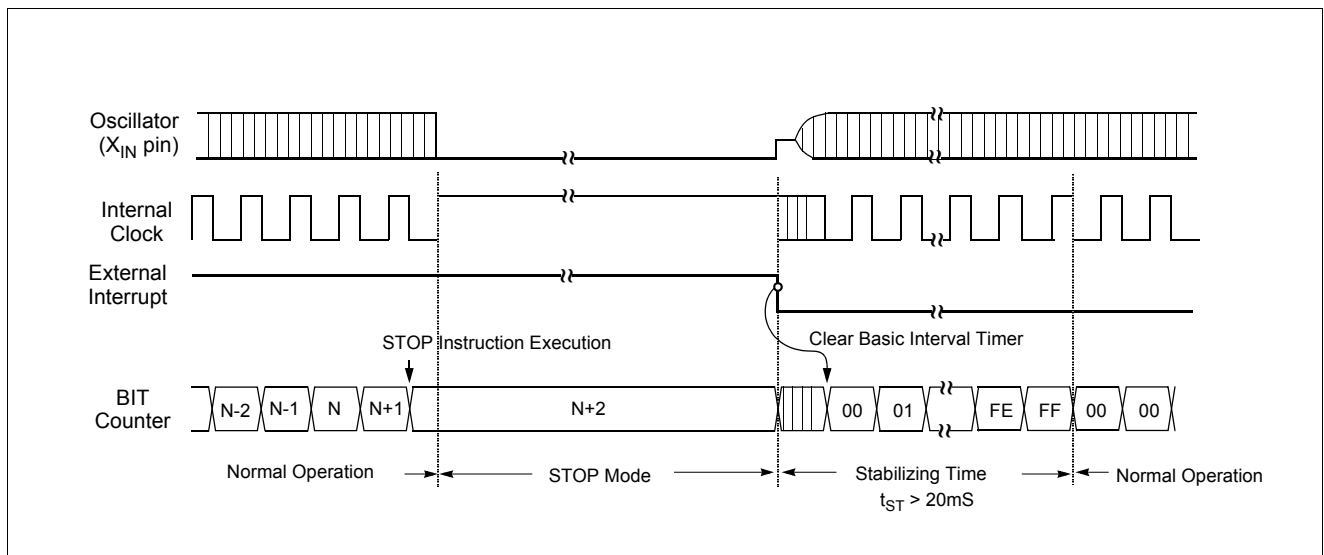

Figure 18-2 Timing of STOP Mode Release by External Interrupt



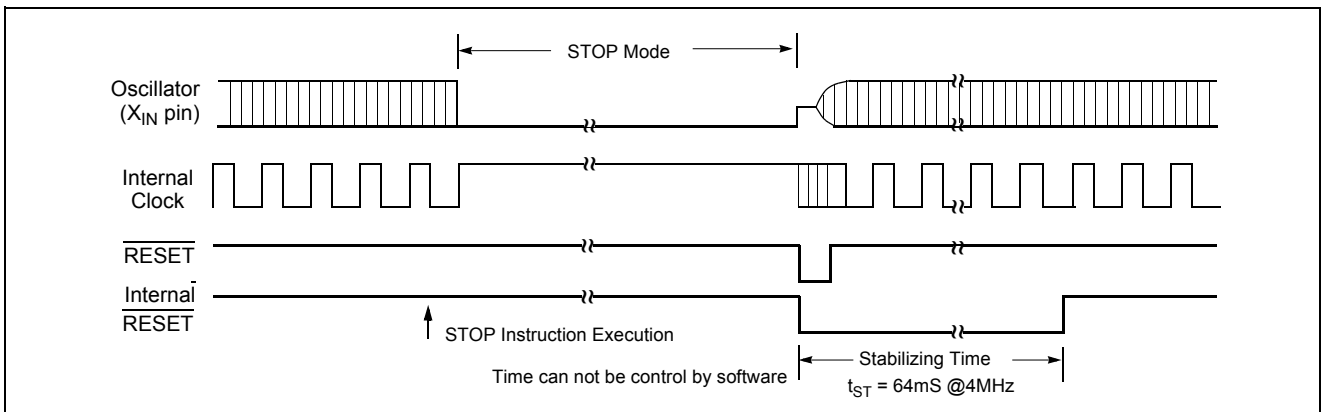

Figure 18-3 Timing of STOP Mode Release by RESET

### 18.2 STOP Mode using Internal RCWDT

In the STOP mode using Internal RC-Oscillated Watchdog Timer, the on-chip oscillator is stopped. But internal RC oscillation circuit is oscillated in this mode. The on-chip RAM and Control registers are held. The port pins out the values held by their respective port data register, port direction registers.

**The Internal RC-Oscillated Watchdog Timer mode is activated by setting the bit RCWDT of CKCTLR to “1”. ( This register should be written by byte operation. If this register is set by bit manipulation instruction, for example “set1” or “clr1” instruction, it may be undesired operation )**

**Note:** After STOP instruction, at least two or more NOP instruction should be written

```
Ex)    LDM WDTR,#1111_1111B
        LDM CKCTLR,#0010_1110B
        STOP
        NOP
        NOP
```

#### Release the STOP mode using internal RCWDT

The exit from STOP mode using Internal RC-Oscillated Watchdog Timer is hardware reset or external interrupt. Reset re-defines all the Control registers but does not change the on-chip RAM. External interrupts allow both on-chip RAM and Control

registers to retain their values.

If I-flag = 1, the normal interrupt response takes place. In this case, if the bit WDTON of CKCTLR is set to “0” and the bit WDTE of IENH is set to “1”, the device will execute the watchdog timer interrupt service routine.(Figure 18-4 ) However, if the bit WDTON of CKCTLR is set to “1”, the device will generate the internal RESET signal and execute the reset processing. (Figure 18-5 )

If I-flag = 0, the chip will resume execution starting with the instruction following the STOP instruction. It will not vector to interrupt service routine.( refer to Figure 18-1 )

When exit from STOP mode using Internal RC-Oscillated Watchdog Timer by external interrupt, the oscillation stabilization time is required to normal operation. Figure 18-4 shows the timing diagram. When release the Internal RC-Oscillated Watchdog Timer mode, the basic interval timer is activated on wake-up. It is increased from 00<sub>H</sub> until FF<sub>H</sub> . The count overflow is set to start normal operation. Therefore, before STOP instruction, user must be set its relevant prescaler divide ratio to have long enough time (more than 20msec). This guarantees that oscillator has started and stabilized.

By reset, exit from STOP mode using internal RC-Oscillated Watchdog Timer is shown in Figure 18-5 .

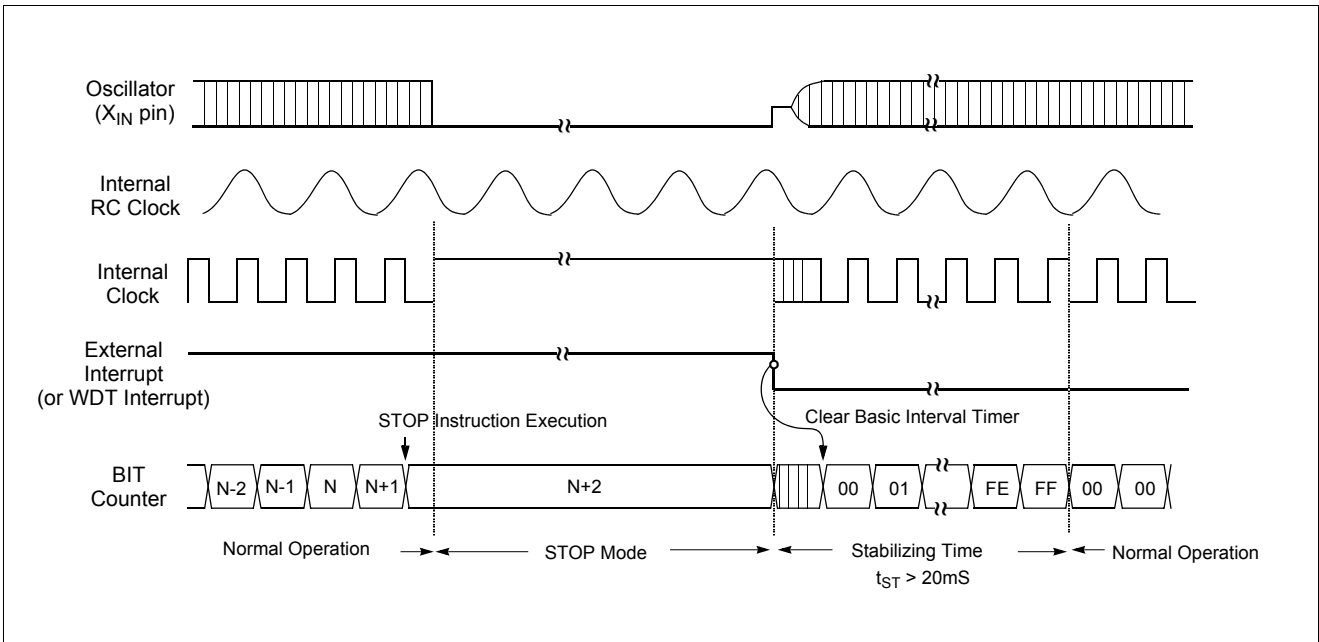

Figure 18-4 STOP Mode Releasing by External Interrupt or WDT Interrupt(using RCWDT)

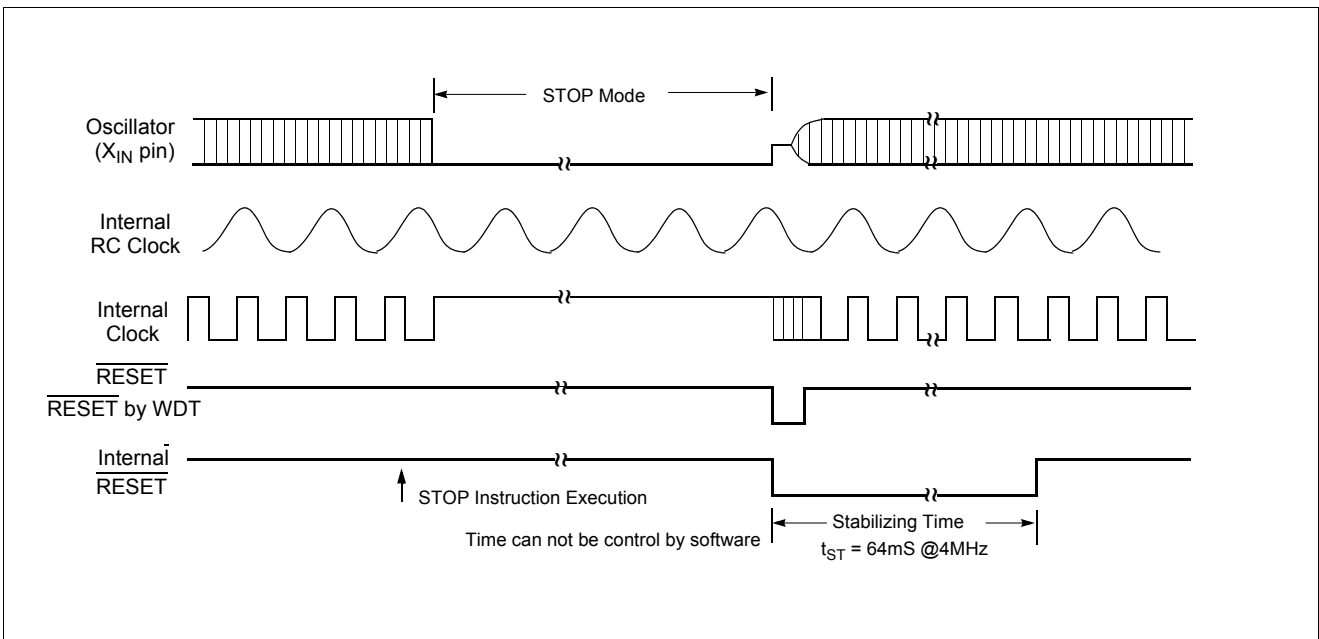

Figure 18-5 STOP Mode Releasing by RESET(using RCWDT)

### 18.3 Wake-up Timer Mode

In the Wake-up Timer mode, the on-chip oscillator is not stopped. Except the Prescaler(only 2048 divided ratio), Timer0 and Timer2, all functions are stopped, but the on-chip RAM and Control registers are held. The port pins out the values held by their respective port data register, port direction registers.

The Wake-up Timer mode is activated by execution of STOP instruction after setting the bit WAKEUP of CKCTLR to "1". (This register should be written by byte operation. If this register is set by bit manipulation instruction, for example "set1" or "clr1" instruction, it may be undesired operation)

**Note:** After STOP instruction, at least two or more NOP instruction should be written

```
Ex)    LDM TDR0,#0FFH
        LDM TM0,#0001_1011B
        LDM CKCTLR,#0100_1110B
        STOP
        NOP
        NOP
```

In addition, the clock source of timer0 and timer2 should be selected to 2048 divided ratio. Otherwise, the wake-up function can not work. And the timer0 and timer2 can be operated as 16-bit timer with timer1 and timer3(refer to timer function). The period of wake-up function is varied by setting the timer data register0, TDR0 or timer data register2, TDR2.

**Release the Wake-up Timer mode**

The exit from Wake-up Timer mode is hardware reset, Timer0(Timer2) overflow or external interrupt. Reset re-defines all the Control registers but does not change the on-chip RAM. External interrupts and Timer0(Timer2) overflow allow both on-chip RAM and Control registers to retain their values.

If I-flag = 1, the normal interrupt response takes place. If I-flag = 0, the chip will resume execution starting with the instruction following the STOP instruction. It will not vector to interrupt service routine.(refer to Figure 18-1 )

When exit from Wake-up Timer mode by external interrupt or timer0(Timer2) overflow, the oscillation stabilizing time is not required to normal operation. Because this mode do not stop the on-chip oscillator shown as Figure 18-6 .

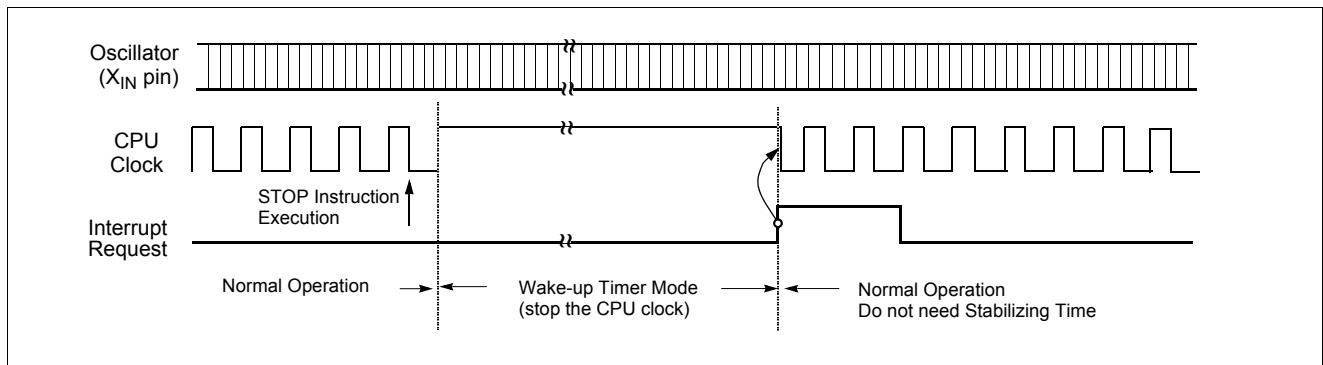

**Figure 18-6 Wake-up Timer Mode Releasing by External Interrupt or Timer0(Timer2) Interrupt**

**18.4 Minimizing Current Consumption**

The Stop mode is designed to reduce power consumption. To minimize current drawn during Stop mode, the user should turn-off output drivers that are sourcing or sinking current, if it is practical.

**Note:** In the STOP operation, the power dissipation associated with the oscillator and the internal hardware is lowered; however, the power dissipation associated with the pin interface (depending on the external circuitry and program) is not directly determined by the hardware operation of the STOP feature. This point should be little current flows when the input level is stable at the power voltage level ( $V_{DD}/V_{SS}$ ); however, when the input level becomes higher than the power voltage level (by approximately 0.3V), a current begins to flow. Therefore, if cutting off the output transistor at an I/O port puts the pin signal into the high-impedance state, a current flow across the ports input transistor, requiring it to fix the level by pull-up or other means.

It should be set properly that current flow through port doesn't exist.

First consider the setting to input mode. Be sure that there is no current flow after considering its relationship with external circuit. In input mode, the pin impedance viewing from external MCU is very high that the current doesn't flow.

But input voltage level should be  $V_{SS}$  or  $V_{DD}$ . Be careful that if unspecified voltage, i.e. if uncertain voltage level (not  $V_{SS}$  or  $V_{DD}$ ) is applied to input pin, there can be little current (max. 1mA at around 2V) flow.

If it is not appropriate to set as an input mode, then set to output mode considering there is no current flow. Setting to High or Low is decided considering its relationship with external circuit. For example, if there is external pull-up resistor then it is set to output mode, i.e. to High, and if there is external pull-down register, it is set to low.

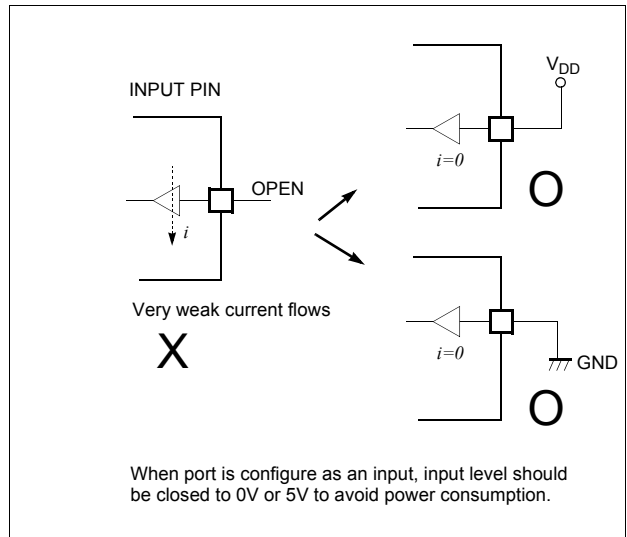
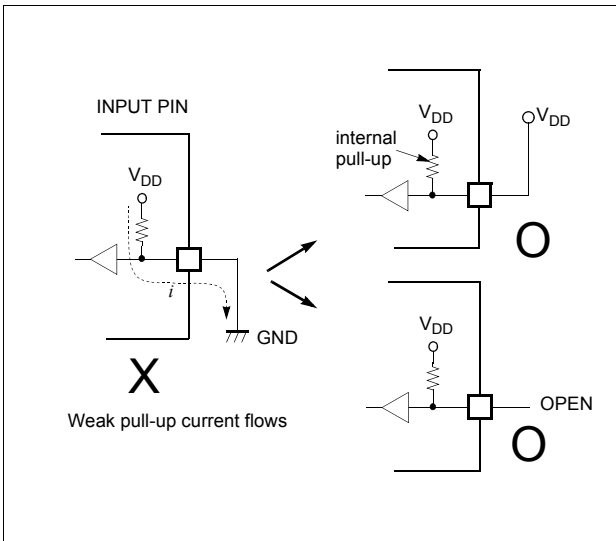

When port is configure as an input, input level should be closed to 0V or 5V to avoid power consumption.

Figure 18-7 Application Example of Unused Input Port

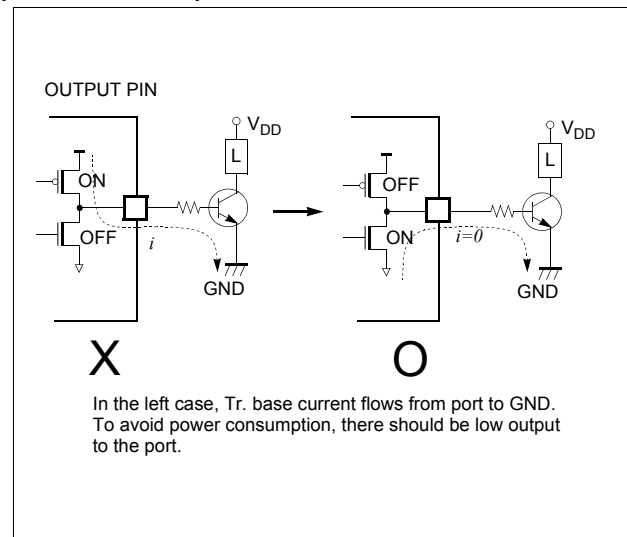
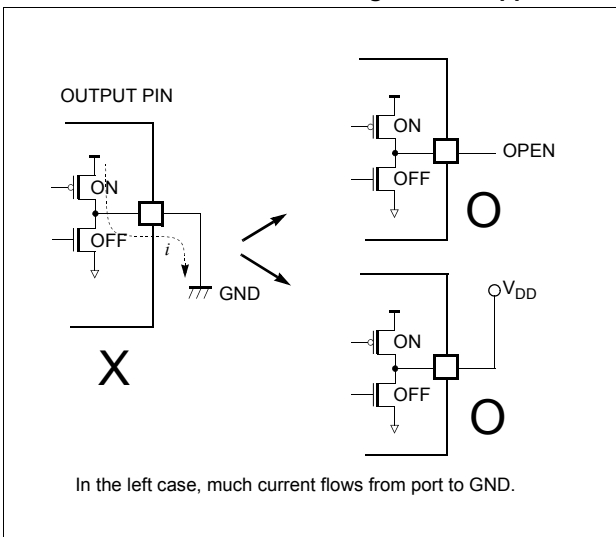

In the left case, Tr. base current flows from port to GND. To avoid power consumption, there should be low output to the port.

Figure 18-8 Application Example of Unused Output Port

### 19. RESET

The reset input is the RESET pin, which is the input to a Schmitt Trigger. A reset is accomplished by holding the RESET pin low for at least 8 oscillator periods, while the oscillator running. After reset, 64ms (at 4 MHz) add with 7 oscillator periods are required to start execution as shown in Figure 19-1 .

Internal RAM is not affected by reset. When  $V_{DD}$  is turned on, the RAM content is indeterminate. Therefore, this RAM should be initialized before reading or testing it.

Initial state of each register is shown as Table 8-1 .

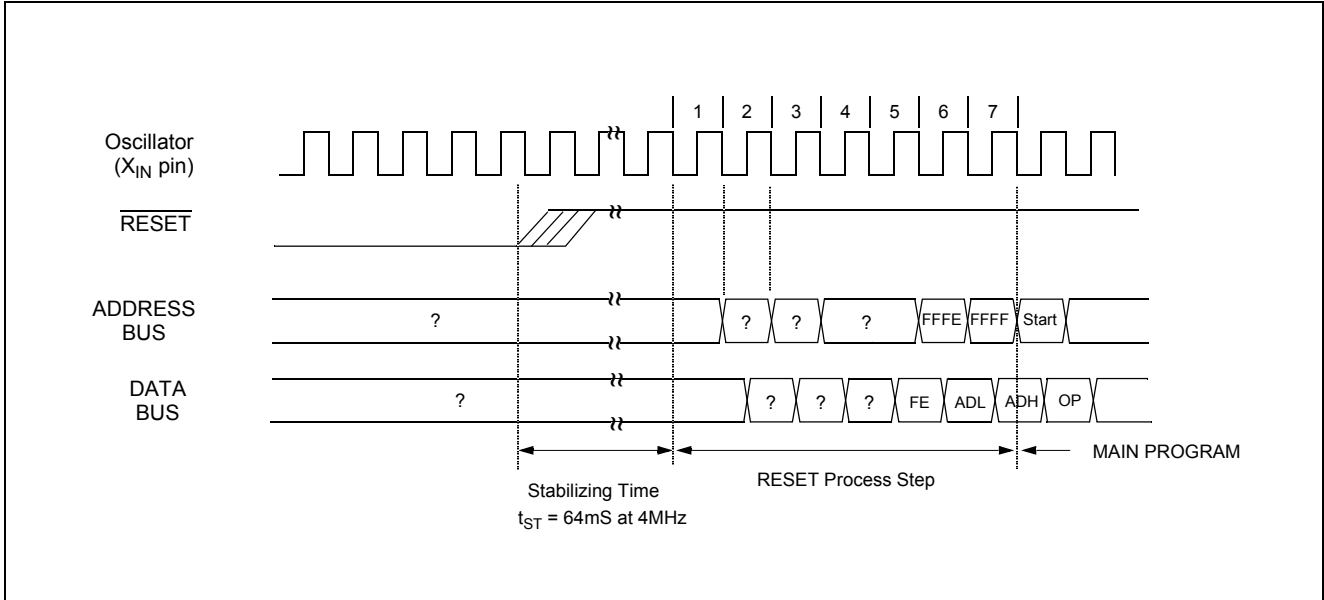

Figure 19-1 Timing Diagram after RESET

A power-up example where  $\overline{\text{RESET}}$  is connected to external reset circuit is shown in Figure 19-2 .  $V_{DD}$  is allowed to rise and stabi-

lize before bringing  $\overline{\text{RESET}}$  high. The chip will actually come out of reset and start the Basic Interval Timer after  $\overline{\text{RESET}}$  goes high.

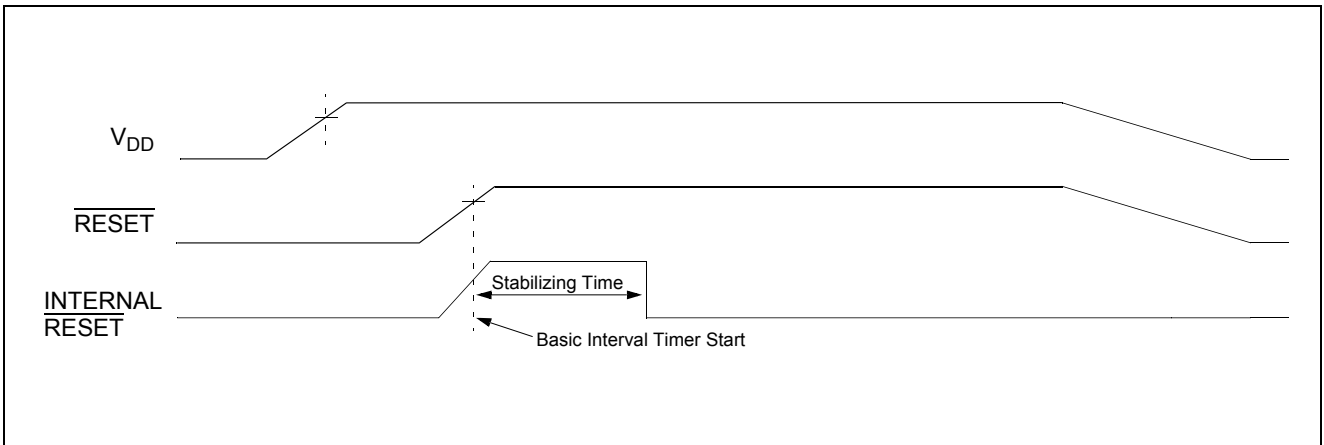

Figure 19-2 Time-out Sequence On Power-up

**Note:** When the device starts normal operation (exits the reset condition), device operating parameters (voltage, frequency, temperature, etc.) must be meet to ensure operation. If these conditions are not met, the device must be held in reset until the operating conditions are met

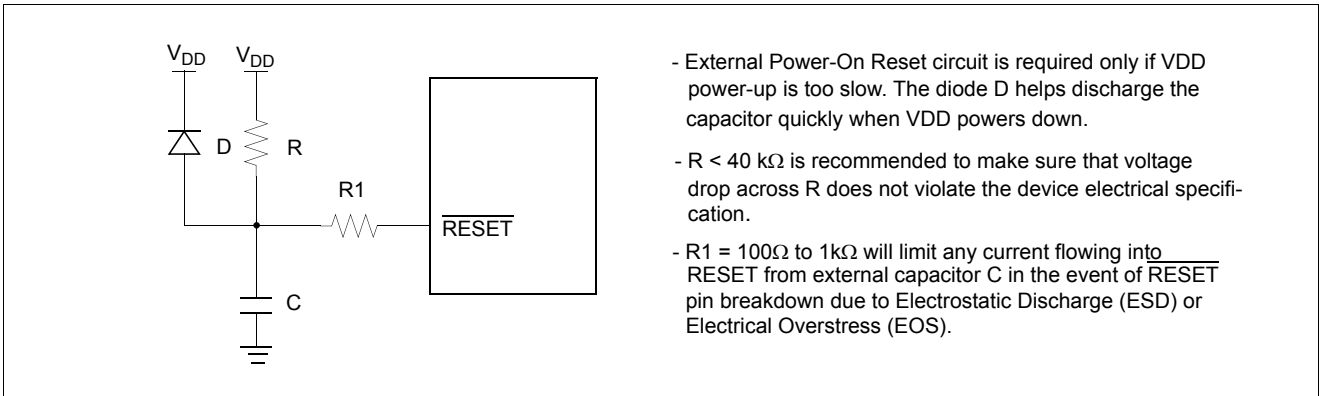

Figure 19-3 EXTERNAL POWERON RESET CIRCUIT (FOR SLOW V<sub>DD</sub> POWER-UP)

• Address Fail Reset

The Address Fail Reset is the function to reset the system by checking abnormal address or unwished address caused by external noise, which couldn't be returned to normal operation and

would be malfunction state. If the CPU fetch the instruction from beyond area not in main user area address C000<sub>H</sub>~FFFF<sub>H</sub>, in that case the address fail reset is occurred.

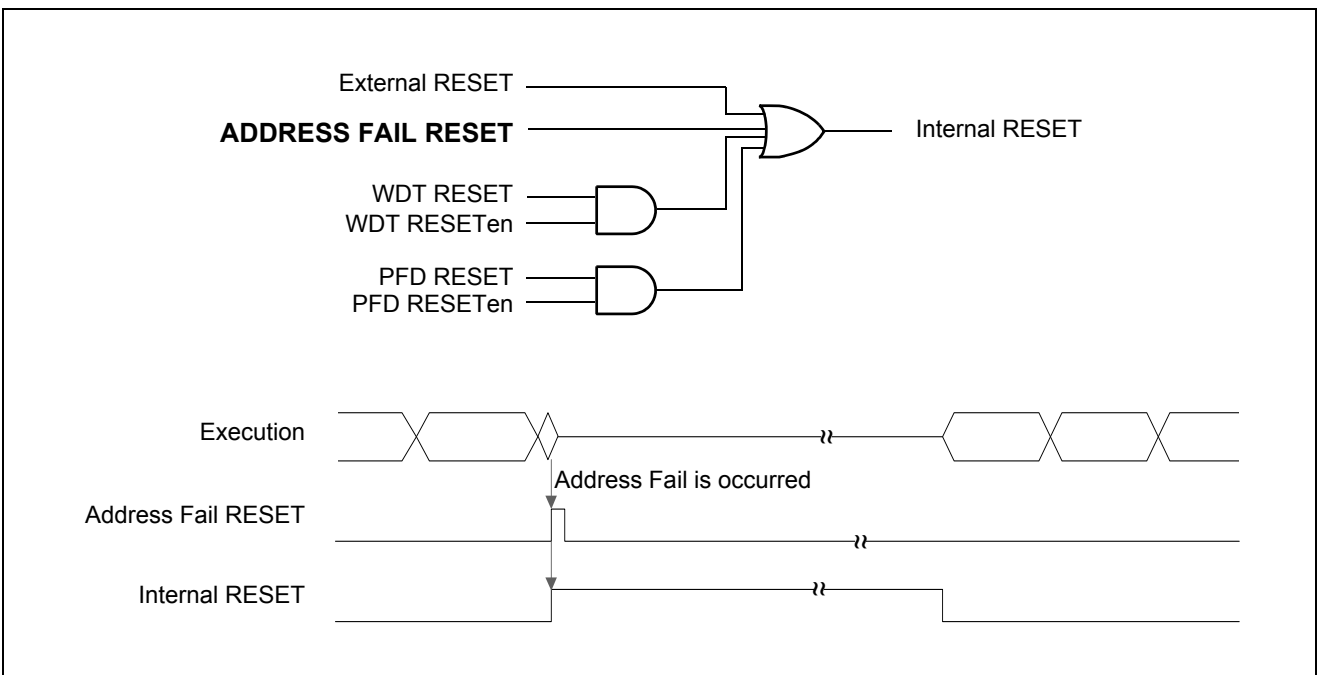

Figure 19-4 The operation of Address Fail RESET

## 20. POWER FAIL PROCESSOR

The HMS87C1X04B/08B/16B has an on-chip power fail detection circuitry to immunize against power noise. A configuration register, PFDR, can enable (if clear/programmed) or disable (if set) the Power-fail Detect circuitry. If  $V_{DD}$  falls below 2.1~3.0V range for longer than 50 nS, the Power fail situation may reset

MCU according to PFS bit of PFDR.

As below PFDR register is not implemented on the in-circuit emulator, user can not experiment with it. Therefore, after final development of user program, this function may be experimented..

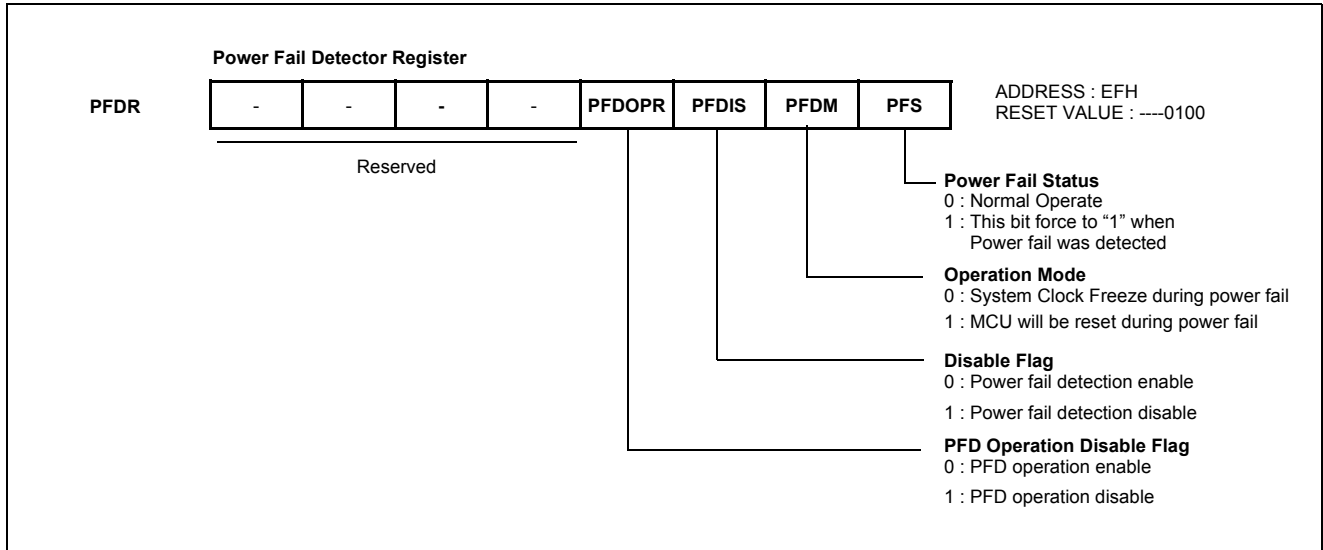

Figure 20-1 Power Fail Detector Register

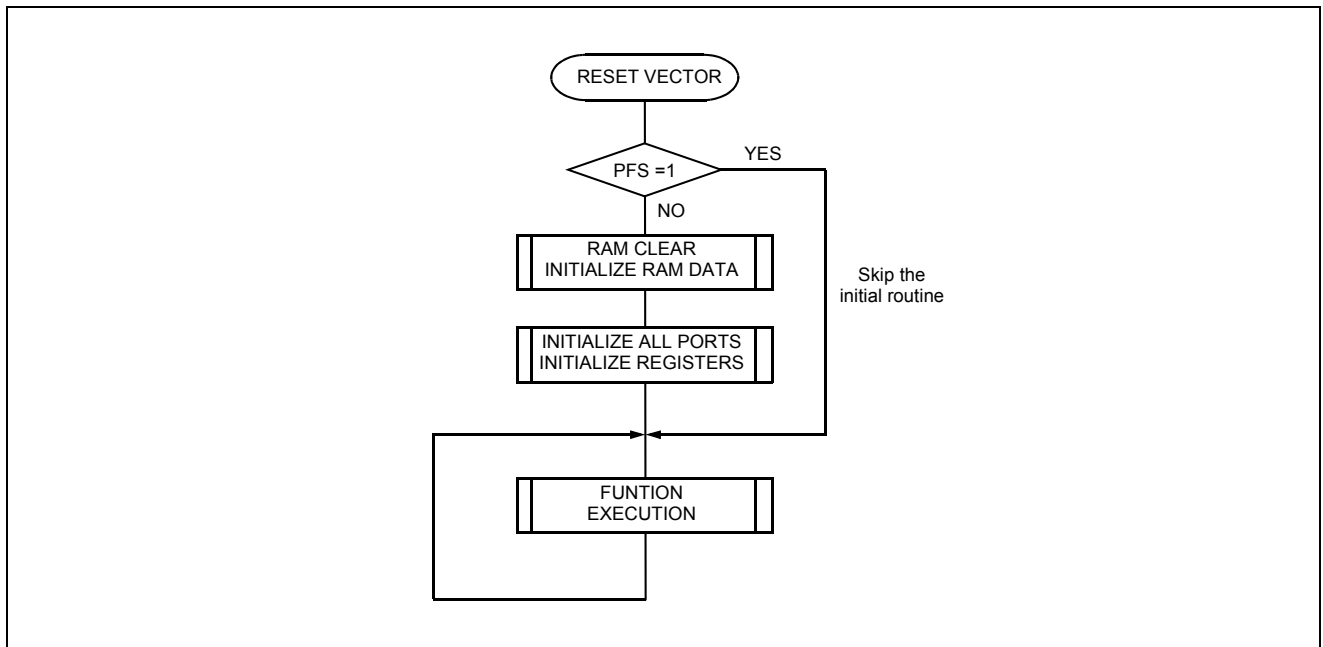

Figure 20-2 Example S/W of RESET by Power fail

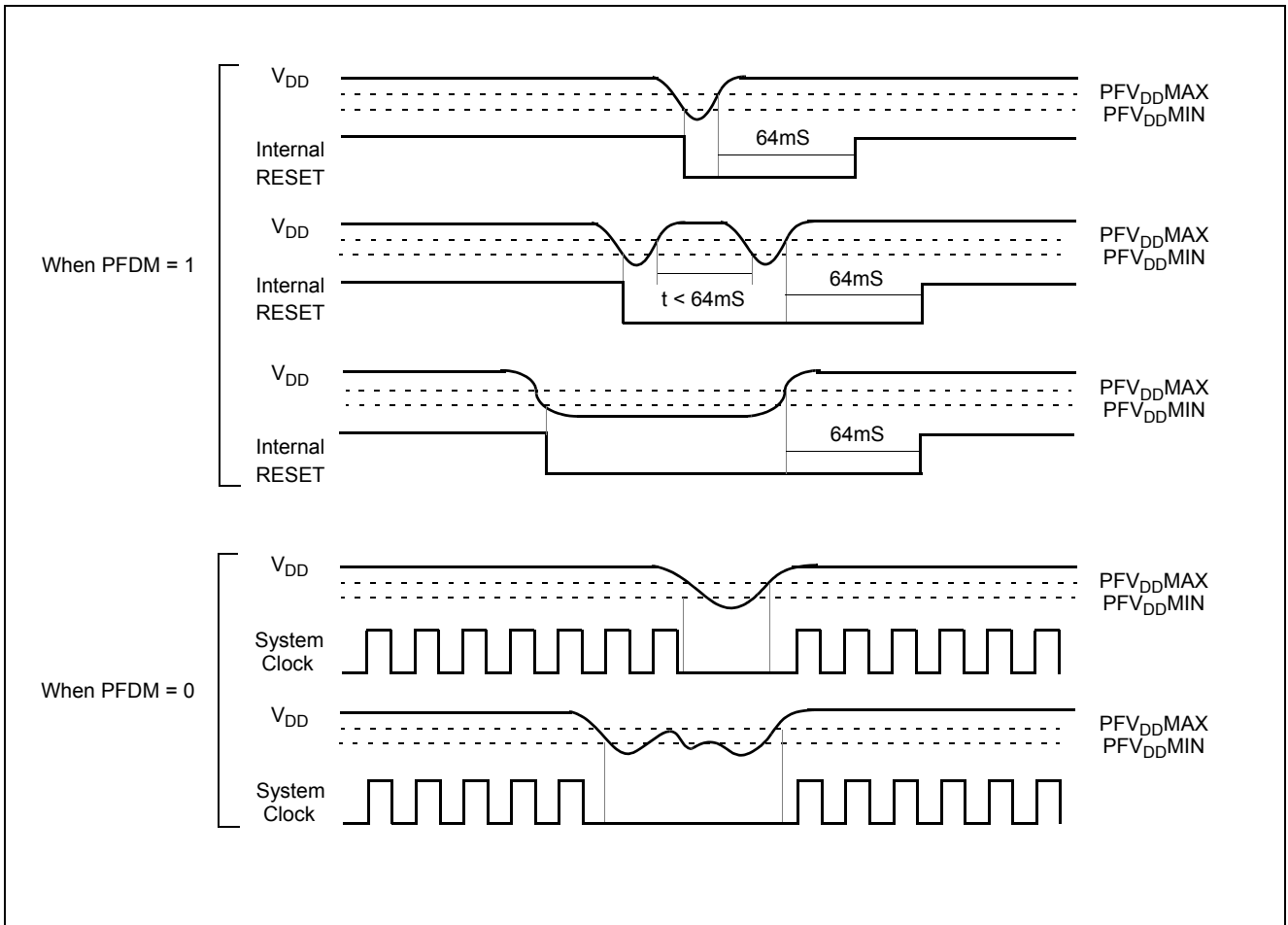

Figure 20-3 Power Fail Processor Situations



## 21. COUNTERMEASURE OF NOISE

### 21.1 Oscillation Noise Protector

The Oscillation Noise Protector(ONP) is used to supply stable internal system clock by excluding the noise which could be entered into oscillator and recovery the oscillation fail. This function could be enabled or disabled by the bit[5] of Configuration Memory (707Fh).

The ONP function is like below.

- Recovery the oscillation wave crushed or loss caused

by high frequency noise.

- Change system clock to the internal oscillation clock when the high frequency noise is continuing.
- Change system clock to the internal oscillation clock when the  $X_{IN}/X_{OUT}$  is shorted or opened, the main oscillation is stopped except by stop instruction and the low frequency noise is entered.

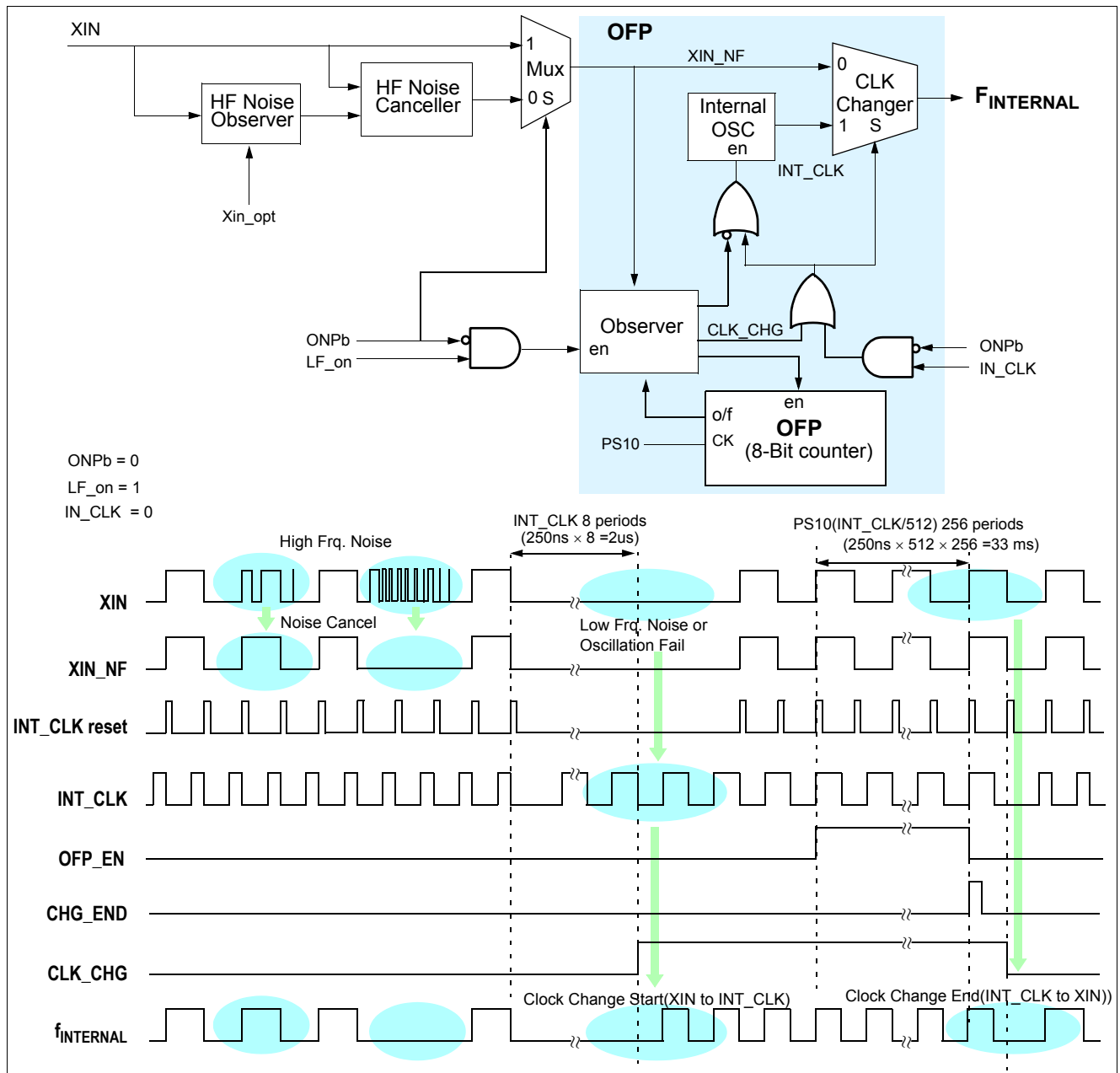

Figure 21-1 Block Diagram of ONP & OFF and Respective Wave Forms

### 21.2 Oscillation Fail Processor

The oscillation fail processor (OFP) can change the clock source from external to internal oscillator when the oscillation fail occurred. This function could be enabled or disabled by the bit[3] of Configuration Memory (707Fh).

And this function can recover the external clock source when the external clock is recovered to normal state.

#### Xin\_opt Option

The X<sub>IN\_opt</sub> is the function to control the amount of noise to be cancelled which entered into noise canceller in ONP, according to external oscillator frequency. If the amount of noise to be cancelled is selected to 40nS by X<sub>IN\_opt</sub>, the noise canceller in ONP cancels the clock over 12.5MHz as a noise. And if the amount of noise to be cancelled is selected to 80nS by X<sub>IN\_opt</sub>, the noise

canceller in ONP cancels the clock over 6.25MHz as a noise.

#### IN\_CLK Option

The IN\_CLK Option is the function to operate the device by using the internal oscillator clock in ONP block as system clock. There is no need to connect the x-tal, resonator, RC and R externally. The user only to connect the X<sub>IN</sub> pin to V<sub>DD</sub>. This function could be selected by the bit[4] of Configuration Memory (707Fh). The characteristics of internal oscillator clock has the period of 250ns±5% at V<sub>DD</sub>=5V and 250ns±10% at whole operating voltage. After selecting the IN\_CLK Option, the period of internal oscillator clock could be checked by X<sub>OUT</sub> outputting clock divided the internal oscillator clock by 4.

### 21.3 Device Configuration Area

The Program Memory is consisted of configuration memory and user program memory. The configuration memory is used to set the environment of system. The device configuration area can be programmed or left unprogrammed to select device configuration

such as oscillation noise protector, internal 4MHz, amount of noise to be cancelled, security, RC-oscillation select bits. This area is not accessible during normal execution but is readable and writable during program / verify.

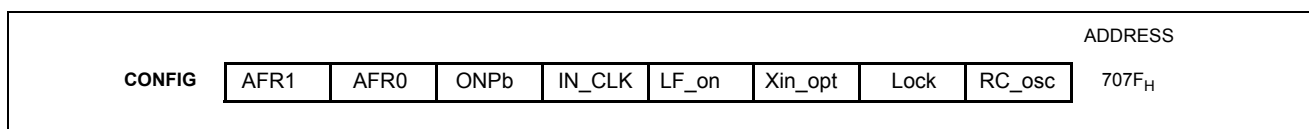

Figure 21-2 Device Configuration Area

	Option	Bit Data	Operation	Remark
<b>CONFIG</b>	AFR1,0	01 or 10	Address Fail RESET Disable	RESET the system when illegal address generated
		00 or 11	Address Fail RESET Enable	
	ONPb	0	OSC Noise Protector Enable	OSC Noise Protector(ONP) Operation En/Disable Bit
		1	OSC Noise Protector Disable	
	IN_CLK	0	Use the Inter 4MHz clock as the Device Osc Disable	Using the internal 4MHz clock without external clock
		1	Use the Inter 4MHz clock as the Device Osc Enable	
	LF_on	0	ONP Low Pass Filter (clock changer) Disable	Change the Inter clock when oscillation failed
		1	ONP Low Pass Filter (clock changer) Enable	
	Xin_opt	0	40nS noise cancel (Xin : 8MHz)	To select the amount of noise of to be cancelled in ONP OSC.
		1	80nS noise cancel (Xin : 4MHz)	
	Lock	0	EPROM Data Read/Pgm Enable	Unlock or lock EPROM data
		1	EPROM Data Read/Pgm Disable	
RC_osc	0	X-tal or Ceramic Oscillation	Select oscillation source	
	1	External RC/ R Oscillation		

Table 21-1 Explanation of configuration bits

## 21.4 Examples of ONP

ONPb	IN_CLK	LF_on	Xin_opt	Description
0	0	0	0	40ns noise canceller
0	0	0	1	80ns noise canceller
0	0	1	0	40ns noise canceller + change the clock source from external to internal 4MHz clock when oscillation failure occurred.
0	0	1	1	80ns noise canceller + change the clock source from external to internal 4MHz clock when oscillation failure occurred
0	1	X	X	using internal 4MHz oscillator regardless of external oscillator
1	X	X	X	ONP disable

**Table 21-1 Examples of ONP**

## 22. OTP PROGRAMMING

### 22.1 EPROM Mode

Mode		Pin Description							Remarks
		A_D7~A_D0	CTL0	CTL1	CTL2	EPROM Enable	V <sub>PP</sub>	V <sub>DD</sub>	
Program	Write	High Addr. (A15~A8)	0	0	0	H	11.5V	5.0V	
		Low Addr. (A7~A0)	0	0	1	H	11.5V	5.0V	
		Data In (D7~D0)	0	1	1	H	11.5V	5.0V	
	Verify	Data Out (D7~D0)	0	1	0	H	11.5V	5.0V	
Read		High Addr. (A15~A8)	0	0	0	H	11.5V	5.0V	
		Low Addr. (A7~A0)	0	0	1	H	11.5V	5.0V	
		Data Out (D7~D0)	0	1	0	H	11.5V	5.0V	

Table 22-1 Description of EPROM mode

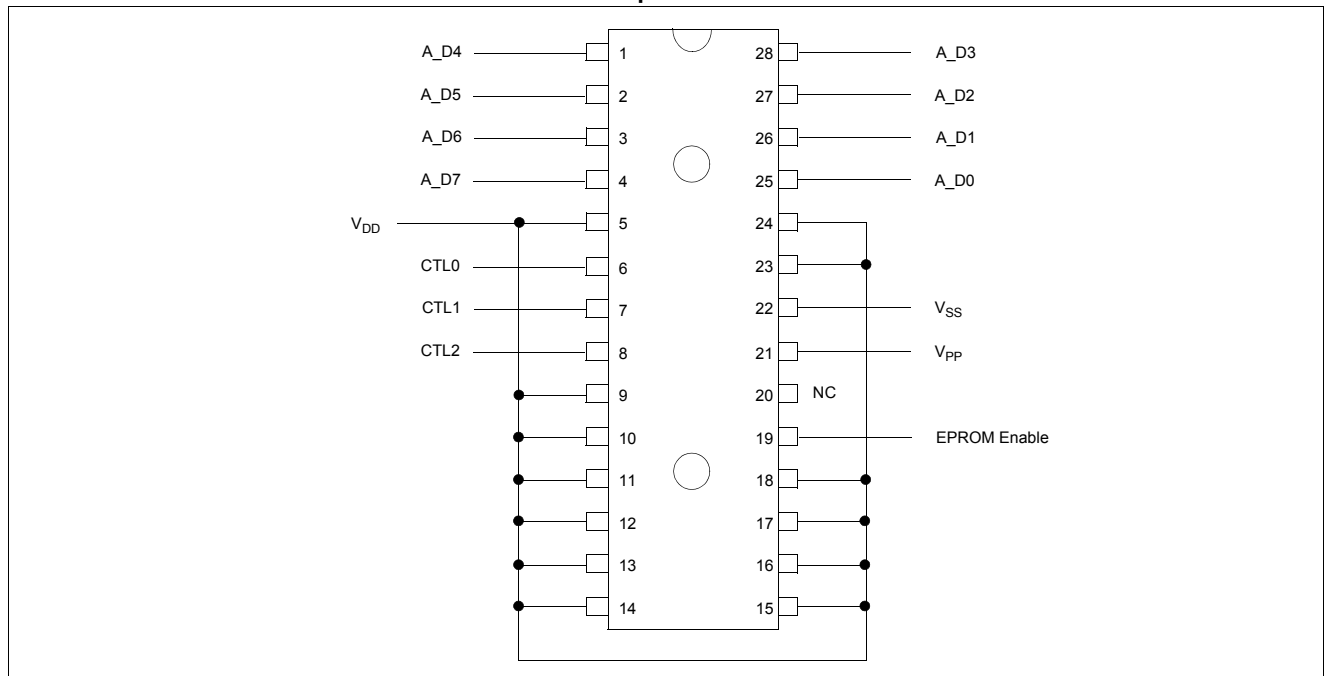

Figure 22-1 Pin Assignment

Pin No.					User Mode	EPROM MODE				
14XXB	15XXB	16XXB	17XXB	18XXB	Pin Name	Pin Name	Description			
1	1	1	1	39	RA4 (AN4)	A_D4	Address Input Data Input/Output	A12	A4	D4
2	2	2	2	40	RA5 (AN5)	A_D5		A13	A5	D5
3	3	3	3	41	RA6 (AN6)	A_D6		A14	A6	D6
4	4	4	4	42	RA7 (AN7)	A_D7		A15	A7	D7
5	5	5	5	43	V <sub>DD</sub>	V <sub>DD</sub>	Connect to V <sub>DD</sub> (5.0V)			
6	6	6	6	44	RB0 (AVref/AN0)	CTL0	Read/Write Control Address/Data Control			
7	7	7	7	1	RB1 (BUZ)	CTL1				
8	8	8	8	2	RB2 (INT0)	CTL2				
19	25	33	35	31	X <sub>IN</sub>	EPROM Enable	High Active, Latch Address in falling edge			
20	26	34	36	32	X <sub>OUT</sub>	NC	No connection			
21	27	35	37	33	RESET	V <sub>PP</sub>	Programming Power (0V, 11.5V)			
22	28	36	38	34	V <sub>SS</sub>	V <sub>SS</sub>	Connect to V <sub>SS</sub> (0V)			
25	29	37	39	35	RA0 (EC0)	A_D0	Address Input Data Input/Output	A8	A0	D0
26	30	38	40	36	RA1 (AN1)	A_D1		A9	A1	D1
27	31	39	41	37	RA2 (AN2)	A_D2		A10	A2	D2
28	32	40	42	38	RA3 (AN3)	A_D3		A11	A3	D3
Other Pins					-	V <sub>DD</sub>	Connect to V <sub>DD</sub> (5.0V)			

Table 22-2 Pin Description in EPROM Mode

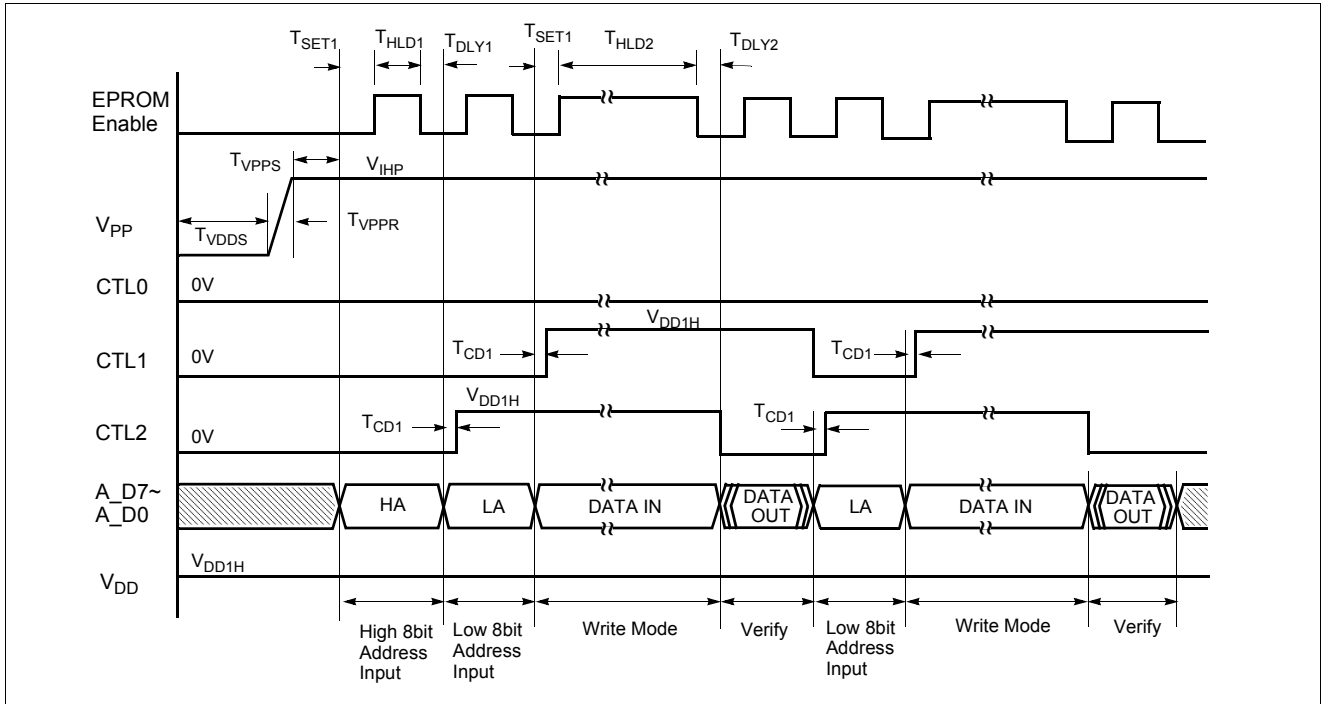

Figure 22-2 Timing Diagram in Program (Write & Verify) Mode

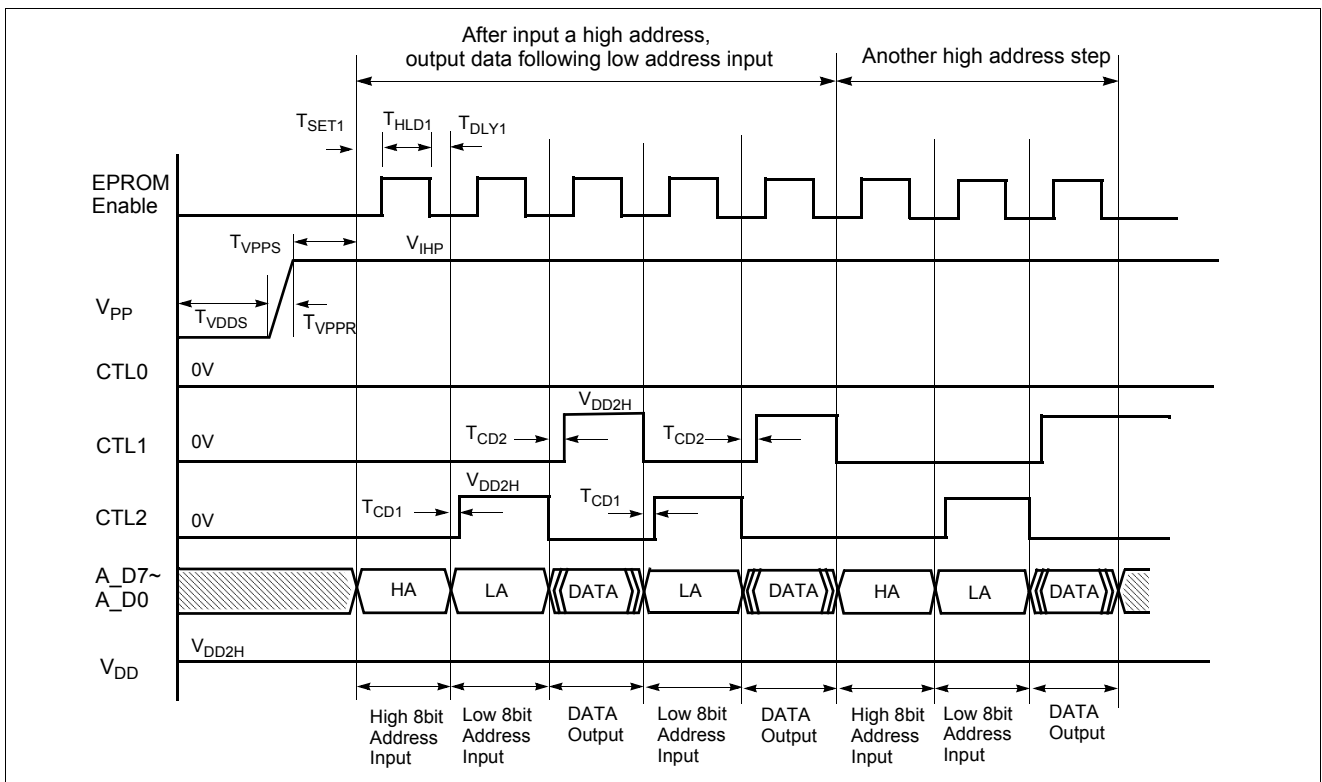

Figure 22-3 Timing Diagram in READ Mode

Parameter	Symbol	MIN	TYP	MAX	Unit
Programming Supply Current	$I_{VPP}$	-	-	50	mA
Supply Current in EPROM Mode	$I_{VDDP}$	-	-	20	mA
$V_{PP}$ Level during Programming	$V_{IHP}$	11.25	11.5	11.75	V
$V_{DD}$ Level in Program Mode	$V_{DD1H}$	4.75	5	5.25	V
$V_{DD}$ Level in Read Mode	$V_{DD2H}$	-	3.0	-	V
CTL2~0 High Level in EPROM Mode	$V_{IHC}$	$0.8V_{DD}$	-	-	V
CTL2~0 Low Level in EPROM Mode	$V_{ILC}$	-	-	$0.2V_{DD}$	V
A_D7~A_D0 High Level in EPROM Mode	$V_{IHAD}$	$0.9V_{DD}$	-	-	V
A_D7~A_D0 Low Level in EPROM Mode	$V_{ILAD}$	-	-	$0.1V_{DD}$	V
$V_{DD}$ Saturation Time	$T_{VDDS}$	1	-	-	mS
$V_{PP}$ Setup Time	$T_{VPPR}$	-	-	1	mS
$V_{PP}$ Saturation Time	$T_{VPPS}$	1	-	-	mS
EPROM Enable Setup Time after Data Input	$T_{SET1}$		$200\pm 10\%$		nS
EPROM Enable Hold Time after $T_{SET1}$	$T_{HLD1}$		$500\pm 10\%$		nS
EPROM Enable Delay Time after $T_{HLD1}$	$T_{DLY1}$		$200\pm 10\%$		nS
EPROM Enable Hold Time in Write Mode	$T_{HLD2}$		$50\pm 10\%$		nS
EPROM Enable Delay Time after $T_{HLD2}$	$T_{DLY2}$		$200\pm 10\%$		nS
CTL2,1 Setup Time after Low Address input and Data input	$T_{CD1}$		$100\pm 10\%$		nS
CTL1 Setup Time before Data output in Read and Verify Mode	$T_{CD2}$		$100\pm 10\%$		nS

Table 22-3 AC/DC Requirements for Program/Read Mode

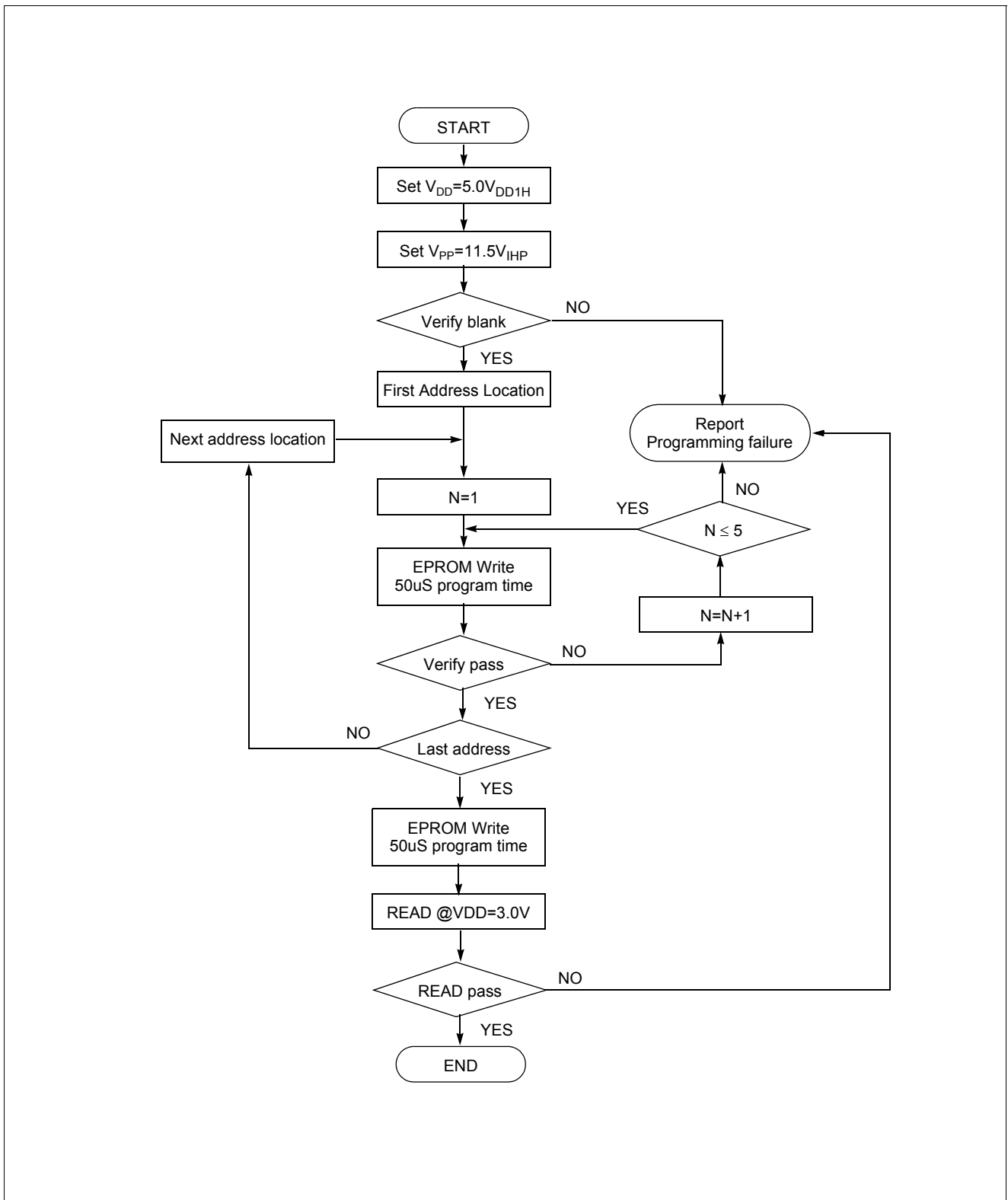

Figure 22-4 Programming Flow Chart



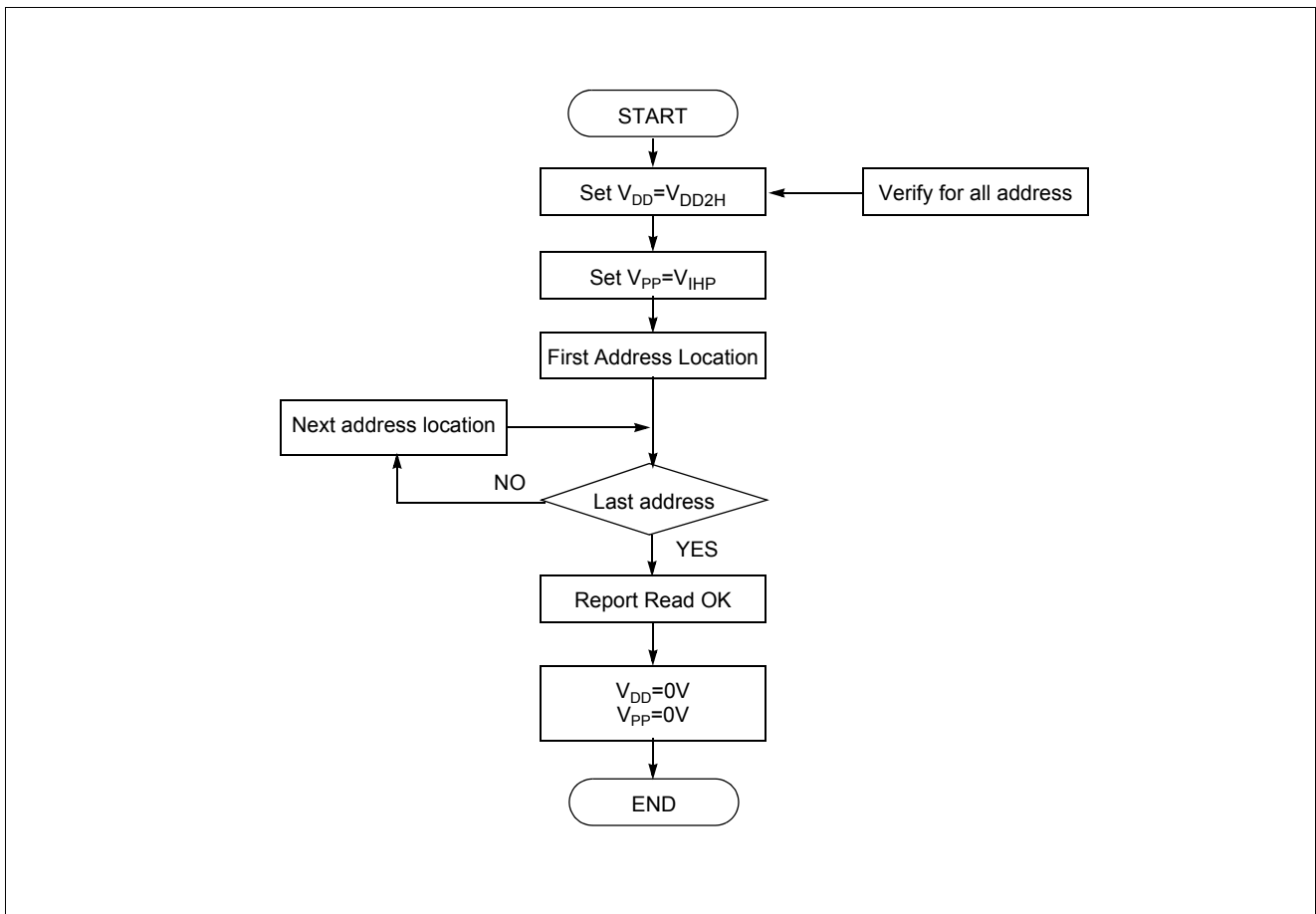

Figure 22-5 Reading Flow Chart



# **APPENDIX**



## APPENDIX

### A. INSTRUCTION MAP

LOW HIGH	0000 00	00001 01	00010 02	00011 03	00100 04	00101 05	00110 06	00111 07	01000 08	01001 09	01010 0A	01011 0B	01100 0C	01101 0D	01110 0E	01111 0F
000	-	SET1 dp.bit	BBS A.bit,rel	BBS dp.bit,rel	ADC #imm	ADC dp	ADC dp+X	ADC !abs	ASL A	ASL dp	TCALL 0	SETA1 .bit	BIT dp	POP A	PUSH A	BRK
001	CLRC				SBC #imm	SBC dp	SBC dp+X	SBC !abs	ROL A	ROL dp	TCALL 2	CLRA1 .bit	COM dp	POP X	PUSH X	BRA rel
010	CLRG				CMP #imm	CMP dp	CMP dp+X	CMP !abs	LSR A	LSR dp	TCALL 4	NOT1 M.bit	TST dp	POP Y	PUSH Y	PCALL Upage
011	DI				OR #imm	OR dp	OR dp+X	OR !abs	ROR A	ROR dp	TCALL 6	OR1 OR1B	CMPX dp	POP PSW	PUSH PSW	RET
100	CLRv				AND #imm	AND dp	AND dp+X	AND !abs	INC A	INC dp	TCALL 8	AND1 AND1B	CMPY dp	CBNE dp+X	TXSP	INC X
101	SETC				EOR #imm	EOR dp	EOR dp+X	EOR !abs	DEC A	DEC dp	TCALL 10	EOR1 EOR1B	DBNE dp	XMA dp+X	TSPX	DEC X
110	SETG				LDA #imm	LDA dp	LDA dp+X	LDA !abs	TXA	LDY dp	TCALL 12	LDC LDCB	LDX dp	LDX dp+Y	XCN	DAS
111	EI				LDM dp,#imm	STA dp	STA dp+X	STA !abs	TAX	STY dp	TCALL 14	STC M.bit	STX dp	STX dp+Y	XAX	STOP

LOW HIGH	10000 10	10001 11	10010 12	10011 13	10100 14	10101 15	10110 16	10111 17	11000 18	11001 19	11010 1A	11011 1B	11100 1C	11101 1D	11110 1E	11111 1F
000	BPL rel	CLR1 dp.bit	BBC A.bit,rel	BBC dp.bit,rel	ADC {X}	ADC !abs+Y	ADC [dp+X]	ADC [dp]+Y	ASL !abs	ASL dp+X	TCALL 1	JMP !abs	BIT !abs	ADDW dp	LDX #imm	JMP [!abs]
001	BVC rel				SBC {X}	SBC !abs+Y	SBC [dp+X]	SBC [dp]+Y	ROL !abs	ROL dp+X	TCALL 3	CALL !abs	TEST !abs	SUBW dp	LDY #imm	JMP [dp]
010	BCC rel				CMP {X}	CMP !abs+Y	CMP [dp+X]	CMP [dp]+Y	LSR !abs	LSR dp+X	TCALL 5	MUL	TCLR1 !abs	CMPW dp	CMPX #imm	CALL [dp]
011	BNE rel				OR {X}	OR !abs+Y	OR [dp+X]	OR [dp]+Y	ROR !abs	ROR dp+X	TCALL 7	DBNE Y	CMPX !abs	LDYA dp	CMPY #imm	RETI
100	BMI rel				AND {X}	AND !abs+Y	AND [dp+X]	AND [dp]+Y	INC !abs	INC dp+X	TCALL 9	DIV	CMPY !abs	INCW dp	INC Y	TAY
101	BVS rel				EOR {X}	EOR !abs+Y	EOR [dp+X]	EOR [dp]+Y	DEC !abs	DEC dp+X	TCALL 11	XMA {X}	XMA dp	DECW dp	DEC Y	TYA
110	BCS rel				LDA {X}	LDA !abs+Y	LDA [dp+X]	LDA [dp]+Y	LDY !abs	LDY dp+X	TCALL 13	LDA {X}+	LDX !abs	STYA dp	XAY	DAA
111	BEQ rel				STA {X}	STA !abs+Y	STA [dp+X]	STA [dp]+Y	STY !abs	STY dp+X	TCALL 15	STA {X}+	STX !abs	CBNE dp	XYX	NOP

## B. INSTRUCTION SET

## 1. ARITHMETIC/ LOGIC OPERATION

NO.	MNEMONIC	OP CODE	BYTE NO	CYCLE NO	OPERATION	FLAG NVGBHIZC
1	ADC #imm	04	2	2	Add with carry. $A \leftarrow (A) + (M) + C$	NV--H-ZC
2	ADC dp	05	2	3		
3	ADC dp + X	06	2	4		
4	ADC !abs	07	3	4		
5	ADC !abs + Y	15	3	5		
6	ADC [ dp + X ]	16	2	6		
7	ADC [ dp ] + Y	17	2	6		
8	ADC { X }	14	1	3		
9	AND #imm	84	2	2	Logical AND $A \leftarrow (A) \wedge (M)$	N-----Z-
10	AND dp	85	2	3		
11	AND dp + X	86	2	4		
12	AND !abs	87	3	4		
13	AND !abs + Y	95	3	5		
14	AND [ dp + X ]	96	2	6		
15	AND [ dp ] + Y	97	2	6		
16	AND { X }	94	1	3		
17	ASL A	08	1	2	Arithmetic shift left C    7 6 5 4 3 2 1 0 	N-----ZC
18	ASL dp	09	2	4		
19	ASL dp + X	19	2	5		
20	ASL !abs	18	3	5		
21	CMP #imm	44	2	2	Compare accumulator contents with memory contents $(A) - (M)$	N-----ZC
22	CMP dp	45	2	3		
23	CMP dp + X	46	2	4		
24	CMP !abs	47	3	4		
25	CMP !abs + Y	55	3	5		
26	CMP [ dp + X ]	56	2	6		
27	CMP [ dp ] + Y	57	2	6		
28	CMP { X }	54	1	3		
29	CMPX #imm	5E	2	2	Compare X contents with memory contents $(X) - (M)$	N-----ZC
30	CMPX dp	6C	2	3		
31	CMPX !abs	7C	3	4		
32	CMPY #imm	7E	2	2	Compare Y contents with memory contents $(Y) - (M)$	N-----ZC
33	CMPY dp	8C	2	3		
34	CMPY !abs	9C	3	4		
35	COM dp	2C	2	4	1'S Complement : $(dp) \leftarrow \sim(dp)$	N-----Z-
36	DAA	DF	1	3	Decimal adjust for addition	N-----ZC
37	DAS	CF	1	3	Decimal adjust for subtraction	N-----ZC
38	DEC A	A8	1	2	Decrement $M \leftarrow (M) - 1$	N-----Z-
39	DEC dp	A9	2	4		
40	DEC dp + X	B9	2	5		
41	DEC !abs	B8	3	5		
42	DEC X	AF	1	2		
43	DEC Y	BE	1	2		
44	DIV	9B	1	12		

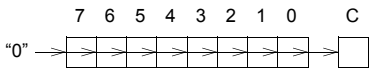
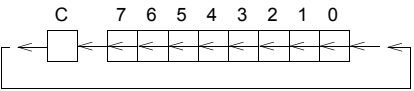
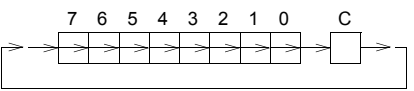
NO.	MNEMONIC	OP CODE	BYTE NO	CYCLE NO	OPERATION	FLAG NVGBHIZC
45	EOR #imm	A4	2	2	Exclusive OR $A \leftarrow (A) \oplus (M)$	N-----Z-
46	EOR dp	A5	2	3		
47	EOR dp + X	A6	2	4		
48	EOR !abs	A7	3	4		
49	EOR !abs + Y	B5	3	5		
50	EOR [ dp + X ]	B6	2	6		
51	EOR [ dp ] + Y	B7	2	6		
52	EOR { X }	B4	1	3		
53	INC A	88	1	2	Increment $M \leftarrow (M) + 1$	N-----Z-
54	INC dp	89	2	4		
55	INC dp + X	99	2	5		
56	INC !abs	98	3	5		
57	INC X	8F	1	2		
58	INC Y	9E	1	2		
59	LSR A	48	1	2	Logical shift right 	N-----ZC
60	LSR dp	49	2	4		
61	LSR dp + X	59	2	5		
62	LSR !abs	58	3	5		
63	MUL	5B	1	9	Multiply : $YA \leftarrow Y \times A$	N-----Z-
64	OR #imm	64	2	2	Logical OR $A \leftarrow (A) \vee (M)$	N-----Z-
65	OR dp	65	2	3		
66	OR dp + X	66	2	4		
67	OR !abs	67	3	4		
68	OR !abs + Y	75	3	5		
69	OR [ dp + X ]	76	2	6		
70	OR [ dp ] + Y	77	2	6		
71	OR { X }	74	1	3		
72	ROL A	28	1	2	Rotate left through carry 	N-----ZC
73	ROL dp	29	2	4		
74	ROL dp + X	39	2	5		
75	ROL !abs	38	3	5		
76	ROR A	68	1	2	Rotate right through carry 	N-----ZC
77	ROR dp	69	2	4		
78	ROR dp + X	79	2	5		
79	ROR !abs	78	3	5		
80	SBC #imm	24	2	2	Subtract with carry $A \leftarrow (A) - (M) - \sim(C)$	NV--HZC
81	SBC dp	25	2	3		
82	SBC dp + X	26	2	4		
83	SBC !abs	27	3	4		
84	SBC !abs + Y	35	3	5		
85	SBC [ dp + X ]	36	2	6		
86	SBC [ dp ] + Y	37	2	6		
87	SBC { X }	34	1	3		
88	TST dp	4C	2	3	Test memory contents for negative or zero ( dp ) - 00 <sub>H</sub>	N-----Z-
89	XCN	CE	1	5	Exchange nibbles within the accumulator $A_7 \sim A_4 \leftrightarrow A_3 \sim A_0$	N-----Z-

## 2. REGISTER / MEMORY OPERATION

NO.	MNEMONIC	OP CODE	BYTE NO	CYCLE NO	OPERATION	FLAG NVGBHIZC
1	LDA #imm	C4	2	2	Load accumulator	N----Z-
2	LDA dp	C5	2	3	$A \leftarrow (M)$	
3	LDA dp + X	C6	2	4		
4	LDA !abs	C7	3	4		
5	LDA !abs + Y	D5	3	5		
6	LDA [ dp + X ]	D6	2	6		
7	LDA [ dp ] + Y	D7	2	6		
8	LDA { X }	D4	1	3		
9	LDA { X }+	DB	1	4	X- register auto-increment : $A \leftarrow (M)$ , $X \leftarrow X + 1$	
10	LDM dp,#imm	E4	3	5	Load memory with immediate data : $(M) \leftarrow \text{imm}$	-----
11	LDX #imm	1E	2	2	Load X-register	N----Z-
12	LDX dp	CC	2	3	$X \leftarrow (M)$	
13	LDX dp + Y	CD	2	4		
14	LDX !abs	DC	3	4		
15	LDY #imm	3E	2	2	Load Y-register	N----Z-
16	LDY dp	C9	2	3	$Y \leftarrow (M)$	
17	LDY dp + X	D9	2	4		
18	LDY !abs	D8	3	4		
19	STA dp	E5	2	4	Store accumulator contents in memory	-----
20	STA dp + X	E6	2	5	$(M) \leftarrow A$	
21	STA !abs	E7	3	5		
22	STA !abs + Y	F5	3	6		
23	STA [ dp + X ]	F6	2	7		
24	STA [ dp ] + Y	F7	2	7		
25	STA { X }	F4	1	4		
26	STA { X }+	FB	1	4	X- register auto-increment : $(M) \leftarrow A$ , $X \leftarrow X + 1$	
27	STX dp	EC	2	4	Store X-register contents in memory	
28	STX dp + Y	ED	2	5	$(M) \leftarrow X$	-----
29	STX !abs	FC	3	5		
30	STY dp	E9	2	4	Store Y-register contents in memory	-----
31	STY dp + X	F9	2	5	$(M) \leftarrow Y$	
32	STY !abs	F8	3	5		
33	TAX	E8	1	2	Transfer accumulator contents to X-register : $X \leftarrow A$	N----Z-
34	TAY	9F	1	2	Transfer accumulator contents to Y-register : $Y \leftarrow A$	N----Z-
35	TSPX	AE	1	2	Transfer stack-pointer contents to X-register : $X \leftarrow \text{sp}$	N----Z-
36	TXA	C8	1	2	Transfer X-register contents to accumulator: $A \leftarrow X$	N----Z-
37	TXSP	8E	1	2	Transfer X-register contents to stack-pointer: $\text{sp} \leftarrow X$	N----Z-
38	TYA	BF	1	2	Transfer Y-register contents to accumulator: $A \leftarrow Y$	N----Z-
39	XAX	EE	1	4	Exchange X-register contents with accumulator : $X \leftrightarrow A$	-----
40	XAY	DE	1	4	Exchange Y-register contents with accumulator : $Y \leftrightarrow A$	-----
41	XMA dp	BC	2	5	Exchange memory contents with accumulator	N----Z-
42	XMA dp+X	AD	2	6	$(M) \leftrightarrow A$	
43	XMA {X}	BB	1	5		
44	XYX	FE	1	4	Exchange X-register contents with Y-register : $X \leftrightarrow Y$	-----



## 3. 16-BIT OPERATION

NO.	MNEMONIC	OP CODE	BYTE NO	CYCLE NO	OPERATION	FLAG NVGBHIZC
1	ADDW dp	1D	2	5	16-Bits add without carry $YA \leftarrow (YA) + (dp + 1)(dp)$	NV--H-ZC
2	CMPW dp	5D	2	4	Compare YA contents with memory pair contents : $(YA) - (dp+1)(dp)$	N----ZC
3	DECW dp	BD	2	6	Decrement memory pair $(dp+1)(dp) \leftarrow (dp+1)(dp) - 1$	N----Z-
4	INCW dp	9D	2	6	Increment memory pair $(dp+1)(dp) \leftarrow (dp+1)(dp) + 1$	N----Z-
5	LDYA dp	7D	2	5	Load YA $YA \leftarrow (dp + 1)(dp)$	N----Z-
6	STYA dp	DD	2	5	Store YA $(dp + 1)(dp) \leftarrow YA$	-----
7	SUBW dp	3D	2	5	16-Bits subtract without carry $YA \leftarrow (YA) - (dp + 1)(dp)$	NV--H-ZC

## 4. BIT MANIPULATION

NO.	MNEMONIC	OP CODE	BYTE NO	CYCLE NO	OPERATION	FLAG NVGBHIZC
1	AND1 M.bit	8B	3	4	Bit AND C-flag : $C \leftarrow (C) \wedge (M.bit)$	-----C
2	AND1B M.bit	8B	3	4	Bit AND C-flag and NOT : $C \leftarrow (C) \wedge \sim(M.bit)$	-----C
3	BIT dp	0C	2	4	Bit test A with memory : $Z \leftarrow (A) \wedge (M), N \leftarrow (M_7), V \leftarrow (M_6)$	MM----Z-
4	BIT !abs	1C	3	5		
5	CLR1 dp.bit	y1	2	4	Clear bit : $(M.bit) \leftarrow "0"$	-----
6	CLRA1 A.bit	2B	2	2	Clear A bit : $(A.bit) \leftarrow "0"$	-----
7	CLRC	20	1	2	Clear C-flag : $C \leftarrow "0"$	-----0
8	CLRG	40	1	2	Clear G-flag : $G \leftarrow "0"$	--0----
9	CLRV	80	1	2	Clear V-flag : $V \leftarrow "0"$	-0--0--
10	EOR1 M.bit	AB	3	5	Bit exclusive-OR C-flag : $C \leftarrow (C) \oplus (M.bit)$	-----C
11	EOR1B M.bit	AB	3	5	Bit exclusive-OR C-flag and NOT : $C \leftarrow (C) \oplus \sim(M.bit)$	-----C
12	LDC M.bit	CB	3	4	Load C-flag : $C \leftarrow (M.bit)$	-----C
13	LDCB M.bit	CB	3	4	Load C-flag with NOT : $C \leftarrow \sim(M.bit)$	-----C
14	NOT1 M.bit	4B	3	5	Bit complement : $(M.bit) \leftarrow \sim(M.bit)$	-----
15	OR1 M.bit	6B	3	5	Bit OR C-flag : $C \leftarrow (C) \vee (M.bit)$	-----C
16	OR1B M.bit	6B	3	5	Bit OR C-flag and NOT : $C \leftarrow (C) \vee \sim(M.bit)$	-----C
17	SET1 dp.bit	x1	2	4	Set bit : $(M.bit) \leftarrow "1"$	-----
18	SETA1 A.bit	0B	2	2	Set A bit : $(A.bit) \leftarrow "1"$	-----
19	SETC	A0	1	2	Set C-flag : $C \leftarrow "1"$	-----1
20	SETG	C0	1	2	Set G-flag : $G \leftarrow "1"$	--1----
21	STC M.bit	EB	3	6	Store C-flag : $(M.bit) \leftarrow C$	-----
22	TCLR1 !abs	5C	3	6	Test and clear bits with A : $A - (M), (M) \leftarrow (M) \wedge \sim(A)$	N----Z-
23	TSET1 !abs	3C	3	6	Test and set bits with A : $A - (M), (M) \leftarrow (M) \vee (A)$	N----Z-

## 5. BRANCH / JUMP OPERATION

NO.	MNEMONIC	OP CODE	BYTE NO	CYCLE NO	OPERATION	FLAG NVGBHIZC
1	BBC A.bit,rel	y2	2	4/6	Branch if bit clear :	-----
2	BBC dp.bit,rel	y3	3	5/7	if ( bit ) = 0 , then $pc \leftarrow ( pc ) + rel$	
3	BBS A.bit,rel	x2	2	4/6	Branch if bit set :	-----
4	BBS dp.bit,rel	x3	3	5/7	if ( bit ) = 1 , then $pc \leftarrow ( pc ) + rel$	
5	BCC rel	50	2	2/4	Branch if carry bit clear if ( C ) = 0 , then $pc \leftarrow ( pc ) + rel$	-----
6	BCS rel	D0	2	2/4	Branch if carry bit set if ( C ) = 1 , then $pc \leftarrow ( pc ) + rel$	-----
7	BEQ rel	F0	2	2/4	Branch if equal if ( Z ) = 1 , then $pc \leftarrow ( pc ) + rel$	-----
8	BMI rel	90	2	2/4	Branch if minus if ( N ) = 1 , then $pc \leftarrow ( pc ) + rel$	-----
9	BNE rel	70	2	2/4	Branch if not equal if ( Z ) = 0 , then $pc \leftarrow ( pc ) + rel$	-----
10	BPL rel	10	2	2/4	Branch if minus if ( N ) = 0 , then $pc \leftarrow ( pc ) + rel$	-----
11	BRA rel	2F	2	4	Branch always $pc \leftarrow ( pc ) + rel$	-----
12	BVC rel	30	2	2/4	Branch if overflow bit clear if ( V ) = 0 , then $pc \leftarrow ( pc ) + rel$	-----
13	BVS rel	B0	2	2/4	Branch if overflow bit set if ( V ) = 1 , then $pc \leftarrow ( pc ) + rel$	-----
14	CALL !abs	3B	3	8	Subroutine call	
15	CALL [dp]	5F	2	8	$M(sp) \leftarrow ( pc_H )$ , $sp \leftarrow sp - 1$ , $M(sp) \leftarrow ( pc_L )$ , $sp \leftarrow sp - 1$ , if !abs, $pc \leftarrow abs$ ; if [dp], $pc_L \leftarrow ( dp )$ , $pc_H \leftarrow ( dp+1 )$ .	-----
16	CBNE dp,rel	FD	3	5/7	Compare and branch if not equal :	-----
17	CBNE dp+X,rel	8D	3	6/8	if ( A ) $\neq$ ( M ) , then $pc \leftarrow ( pc ) + rel$ .	
18	DBNE dp,rel	AC	3	5/7	Decrement and branch if not equal :	-----
19	DBNE Y,rel	7B	2	4/6	if ( M ) $\neq$ 0 , then $pc \leftarrow ( pc ) + rel$ .	
20	JMP !abs	1B	3	3	Unconditional jump	
21	JMP [!abs]	1F	3	5	$pc \leftarrow$ jump address	-----
22	JMP [dp]	3F	2	4		
23	PCALL upage	4F	2	6	U-page call $M(sp) \leftarrow ( pc_H )$ , $sp \leftarrow sp - 1$ , $M(sp) \leftarrow ( pc_L )$ , $sp \leftarrow sp - 1$ , $pc_L \leftarrow ( upage )$ , $pc_H \leftarrow "OFF_H"$ .	-----
24	TCALL n	nA	1	8	Table call : $(sp) \leftarrow ( pc_H )$ , $sp \leftarrow sp - 1$ , $M(sp) \leftarrow ( pc_L )$ , $sp \leftarrow sp - 1$ , $pc_L \leftarrow (Table\ vector\ L)$ , $pc_H \leftarrow (Table\ vector\ H)$	-----

## 6. CONTROL OPERATION &amp; etc.

NO.	MNEMONIC	OP CODE	BYTE NO	CYCLE NO	OPERATION	FLAG NVGBHIZC
1	BRK	0F	1	8	Software interrupt : $B \leftarrow "1"$ , $M(sp) \leftarrow (pc_H)$ , $sp \leftarrow sp-1$ , $M(s) \leftarrow (pc_L)$ , $sp \leftarrow sp - 1$ , $M(sp) \leftarrow (PSW)$ , $sp \leftarrow sp - 1$ , $pc_L \leftarrow (0FFDE_H)$ , $pc_H \leftarrow (0FFDF_H)$ .	---1-0--
2	DI	60	1	3	Disable interrupts : $I \leftarrow "0"$	----0--
3	EI	E0	1	3	Enable interrupts : $I \leftarrow "1"$	----1--
4	NOP	FF	1	2	No operation	-----
5	POP A	0D	1	4	$sp \leftarrow sp + 1$ , $A \leftarrow M(sp)$	-----
6	POP X	2D	1	4	$sp \leftarrow sp + 1$ , $X \leftarrow M(sp)$	
7	POP Y	4D	1	4	$sp \leftarrow sp + 1$ , $Y \leftarrow M(sp)$	
8	POP PSW	6D	1	4	$sp \leftarrow sp + 1$ , $PSW \leftarrow M(sp)$	restored
9	PUSH A	0E	1	4	$M(sp) \leftarrow A$ , $sp \leftarrow sp - 1$	-----
10	PUSH X	2E	1	4	$M(sp) \leftarrow X$ , $sp \leftarrow sp - 1$	
11	PUSH Y	4E	1	4	$M(sp) \leftarrow Y$ , $sp \leftarrow sp - 1$	
12	PUSH PSW	6E	1	4	$M(sp) \leftarrow PSW$ , $sp \leftarrow sp - 1$	
13	RET	6F	1	5	Return from subroutine $sp \leftarrow sp + 1$ , $pc_L \leftarrow M(sp)$ , $sp \leftarrow sp + 1$ , $pc_H \leftarrow M(sp)$	-----
14	RETI	7F	1	6	Return from interrupt $sp \leftarrow sp + 1$ , $PSW \leftarrow M(sp)$ , $sp \leftarrow sp + 1$ , $pc_L \leftarrow M(sp)$ , $sp \leftarrow sp + 1$ , $pc_H \leftarrow M(sp)$	restored
15	STOP	EF	1	3	Stop mode ( halt CPU, stop oscillator )	-----