

**TOSHIBA**

**HN1B01F**

TOSHIBA TRANSISTOR SILICON PNP EPITAXIAL TYPE (PCT PROCESS) SILICON NPN EPITAXIAL TYPE (PCT PROCESS)

# HN1B01F

AUDIO FREQUENCY GENERAL PURPOSE AMPLIFIER APPLICATIONS.

Q1 :

- High Voltage and High Current :  $V_{CEO} = -50V, I_C = -150mA$  (Max.)
- High  $h_{FE}$  :  $h_{FE} = 120 \sim 400$
- Excellent  $h_{FE}$  Linearity :  $h_{FE}(I_C = -0.1mA) / h_{FE}(I_C = -2mA) = 0.95$  (Typ.)

Q2 :

- High Voltage and High Current :  $V_{CEO} = 50V, I_C = 150mA$  (Max.)
- High  $h_{FE}$  :  $h_{FE} = 120 \sim 400$
- Excellent  $h_{FE}$  Linearity :  $h_{FE}(I_C = 0.1mA) / h_{FE}(I_C = 2mA) = 0.95$  (Typ.)

Q1 MAXIMUM RATINGS ( $T_a = 25^\circ C$ )

CHARACTERISTIC	SYMBOL	RATING	UNIT
Collector-Base Voltage	$V_{CBO}$	-50	V
Collector-Emitter Voltage	$V_{CEO}$	-50	V
Emitter-Base Voltage	$V_{EBO}$	-5	V
Collector Current	$I_C$	-150	mA
Base Current	$I_B$	-50	mA

Q2 MAXIMUM RATINGS ( $T_a = 25^\circ C$ )

CHARACTERISTIC	SYMBOL	RATING	UNIT
Collector-Base Voltage	$V_{CBO}$	60	V
Collector-Emitter Voltage	$V_{CEO}$	50	V
Emitter-Base Voltage	$V_{EBO}$	5	V
Collector Current	$I_C$	150	mA
Base Current	$I_B$	30	mA

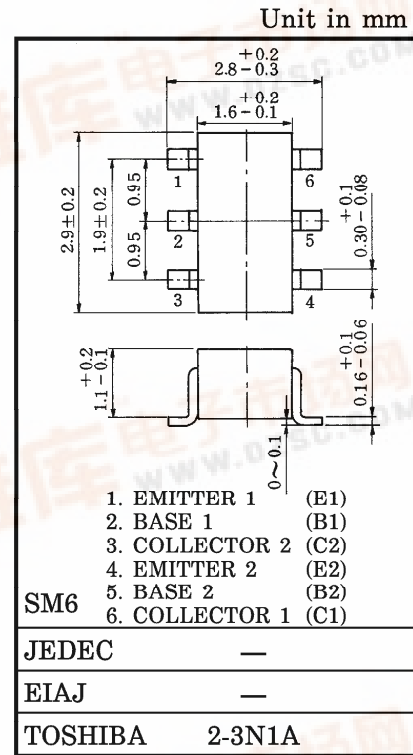

Weight : 0.015g

MARKING

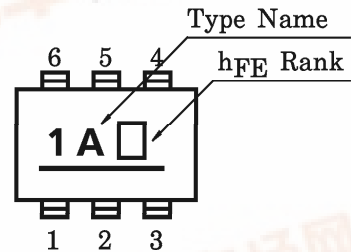

EQUIVALENT CIRCUIT (TOP VIEW)

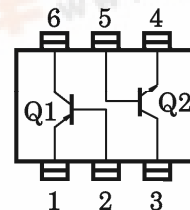

961001FAA2

● TOSHIBA is continually working to improve the quality and the reliability of its products. Nevertheless, semiconductor devices in general can malfunction or fail due to their inherent electrical sensitivity and vulnerability to physical stress. It is the responsibility of the buyer, when utilizing TOSHIBA products, to observe standards of safety, and to avoid situations in which a malfunction or failure of a TOSHIBA product could cause loss of human life, bodily injury or damage to property. In developing your designs, please ensure that TOSHIBA products are used within specified operating ranges as set forth in the most recent products specifications. Also, please keep in mind the precautions and conditions set forth in the TOSHIBA Semiconductor Reliability Handbook.

● The information contained herein is presented only as a guide for the applications of our products. No responsibility is assumed by TOSHIBA CORPORATION for any infringements of intellectual property or other rights of the third parties which may result from its use. No license is granted by implication or otherwise under any intellectual property or other rights of TOSHIBA CORPORATION or others.

● The information contained herein is subject to change without notice.



Q1, Q2 COMMON MAXIMUM RATINGS (Ta = 25°C)

CHARACTERISTIC	SYMBOL	RATING	UNIT
Collector Power Dissipation	PC*	300	mW
Junction Temperature	Tj	125	°C
Storage Temperature Range	Tstg	-55~125	°C

\* Total Rating

Q1 ELECTRICAL CHARACTERISTICS (Ta = 25°C)

CHARACTERISTIC	SYMBOL	TEST CONDITION	MIN.	TYP.	MAX.	UNIT
Collector Cut-off Current	ICBO	V <sub>CB</sub> = -50V, I <sub>E</sub> = 0	—	—	-0.1	μA
Emitter Cut-off Current	IEBO	V <sub>EB</sub> = -5V, I <sub>C</sub> = 0	—	—	-0.1	μA
DC Current Gain	h <sub>FE</sub> (Note)	V <sub>CE</sub> = -6V, I <sub>C</sub> = -2mA	120	—	400	
Collector-Emitter Saturation Voltage	V <sub>CE(sat)</sub>	I <sub>C</sub> = -100mA, I <sub>B</sub> = -10mA	—	-0.1	-0.3	V
Transition Frequency	f <sub>T</sub>	V <sub>CE</sub> = -10V, I <sub>C</sub> = -1mA	—	120	—	MHz
Collector Output Capacitance	C <sub>ob</sub>	V <sub>CB</sub> = -10V, I <sub>E</sub> = 0, f = 1MHz	—	4	—	pF

Q2 ELECTRICAL CHARACTERISTICS (Ta = 25°C)

CHARACTERISTIC	SYMBOL	TEST CONDITION	MIN.	TYP.	MAX.	UNIT
Collector Cut-off Current	ICBO	V <sub>CB</sub> = 60V, I <sub>E</sub> = 0	—	—	0.1	μA
Emitter Cut-off Current	IEBO	V <sub>EB</sub> = 5V, I <sub>C</sub> = 0	—	—	0.1	μA
DC Current Gain	h <sub>FE</sub> (Note)	V <sub>CE</sub> = 6V, I <sub>C</sub> = 2mA	120	—	400	
Collector-Emitter Saturation Voltage	V <sub>CE(sat)</sub>	I <sub>C</sub> = 100mA, I <sub>B</sub> = 10mA	—	0.1	0.25	V
Transition Frequency	f <sub>T</sub>	V <sub>CE</sub> = 10V, I <sub>C</sub> = 1mA	—	150	—	MHz
Collector Output Capacitance	C <sub>ob</sub>	V <sub>CB</sub> = 10V, I <sub>E</sub> = 0, f = 1MHz	—	2	—	pF

Note : h<sub>FE</sub> Classification Y (Y) : 120~240, GR (G) : 200~400  
 ( ) Marking Symbol

## Q1 (PNP TRANSISTOR)

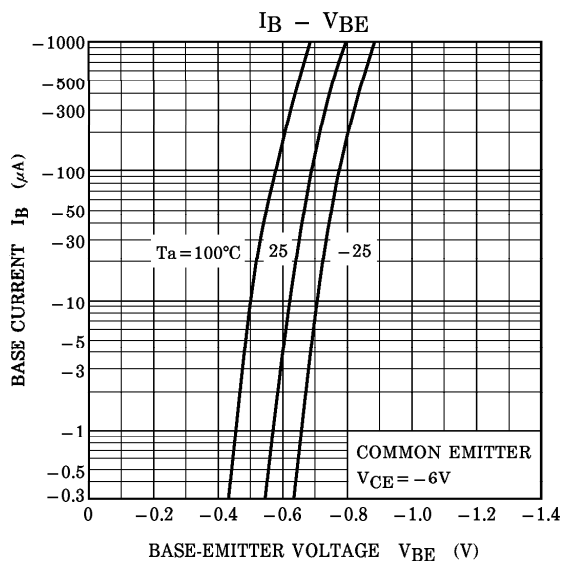
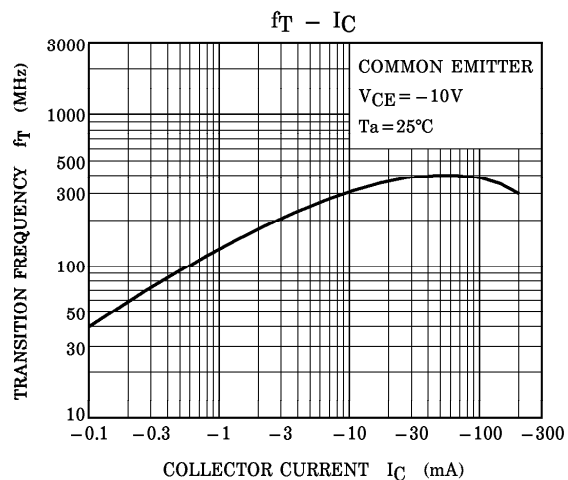
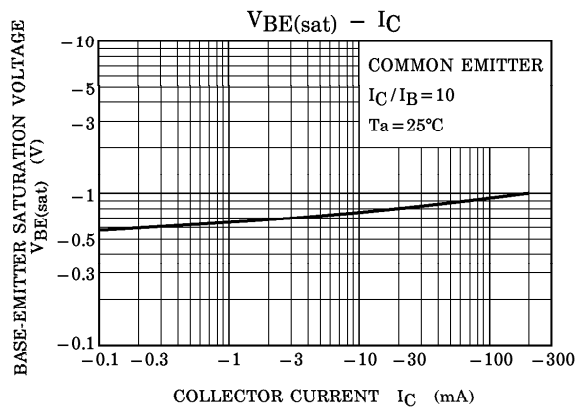
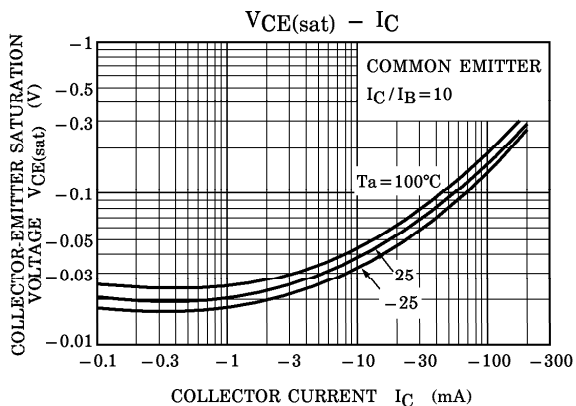
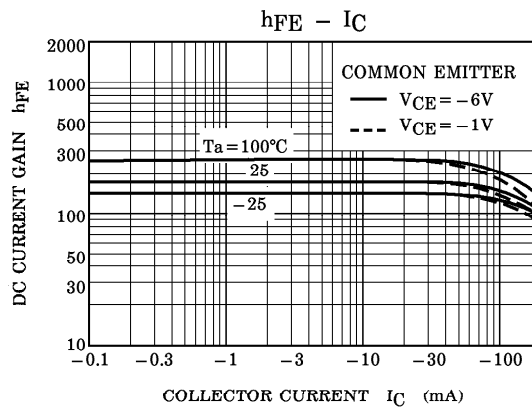
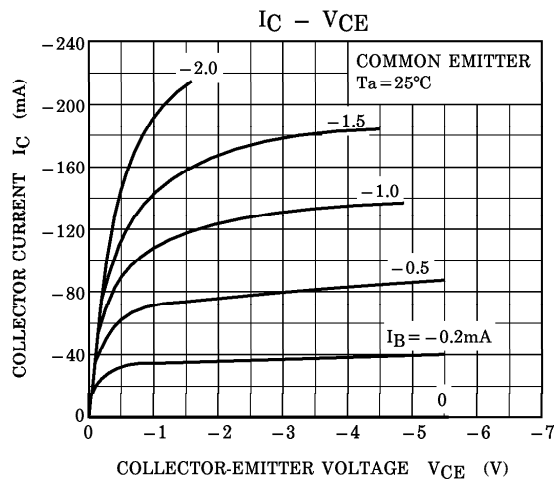

Q2 (NPN TRANSISTOR)

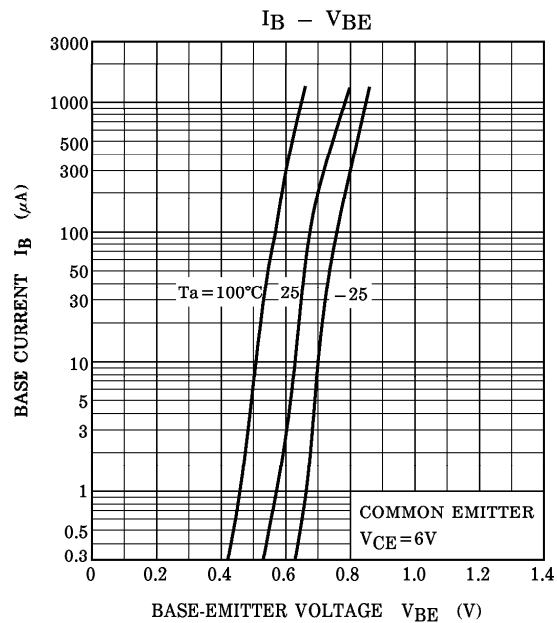
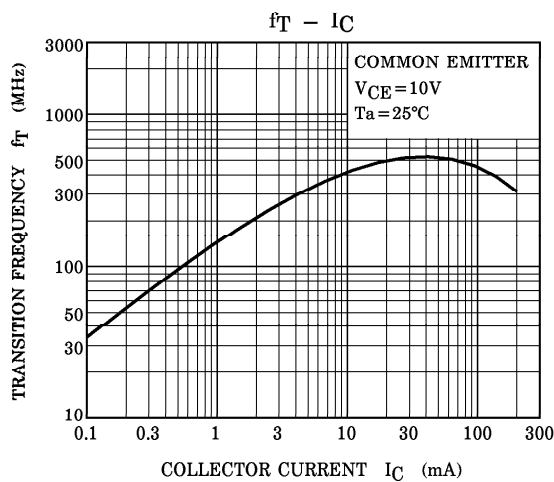
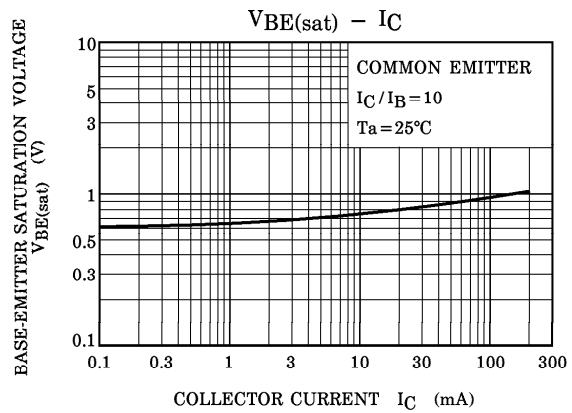
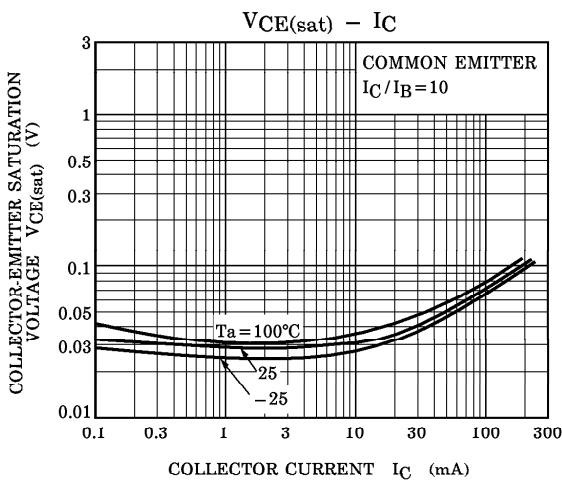
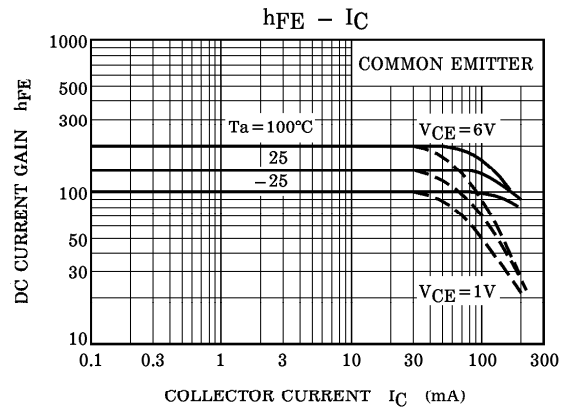
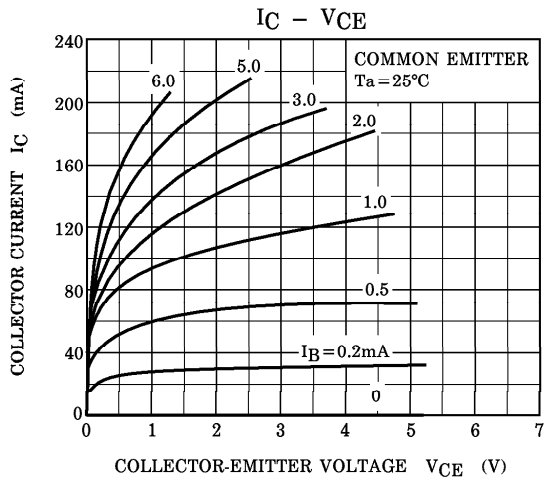

(Q1, Q2 COMMON)

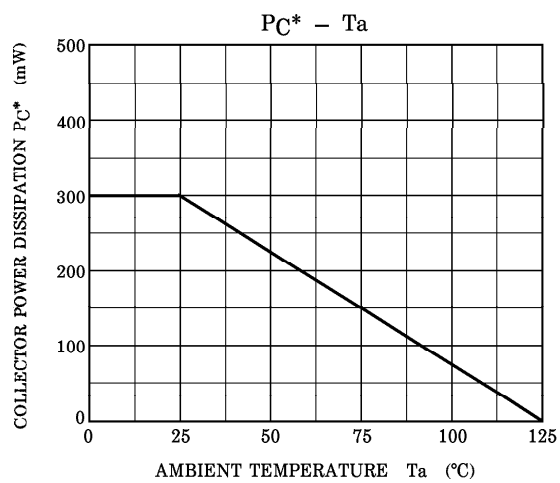

\* : Total Rating