



HT1134A Pin Ball LCD Game

Features

- 1/3 bias, 1/4 duty, 32×4 pattern, 3.0V LCD driver
- 12 kinds of sound effects
- RC oscillator

General Description

HT1134A is an LCD Pin Ball game designed by HOLTEK. It has a built-in sound effect driver to create vivid results. It is much like a real pin ball. This game contains five levels. The higher the level is, the faster is the speed. When the

score reaches a certain number, the level goes up. The highest score is up to 19990. The level can be set up before the game starts. It is not necessary to start from level 1-1.

LCD Pattern

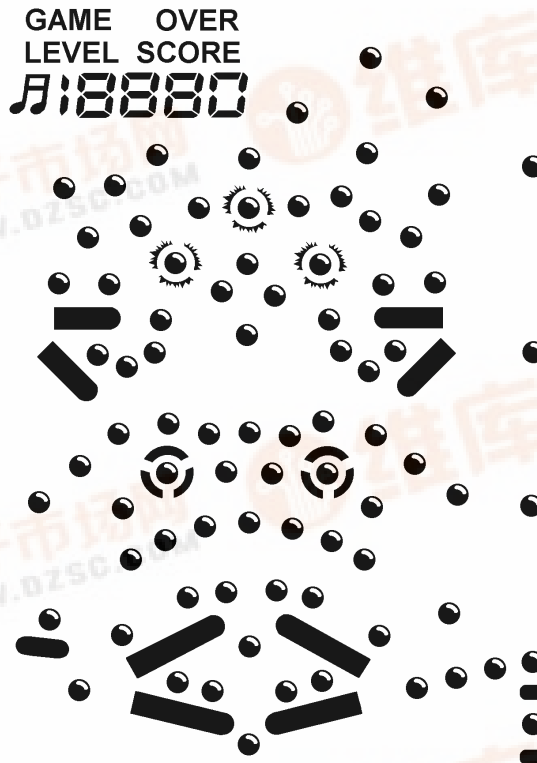

Functional Description

Key description

- **RESET**
Pressing this key at any time resets the system back to the starting condition and the highest score is cleared.
- **PAUSE**
Pressing this key any time after power on, can temporarily stop the game, freeze the screen and stop the sound effects. Press this key again, and the game will continue. During the pause condition, all the other keys have no effect except OFF and RESET key.
- **OFF**
Pressing this key any time after power on, can clear the screen. Except turning on the power again, all the other keys are disabled and the entire system goes into the low power mode. It is similar with the power off condition, however, the highest records are kept.
- **MUTE**
This key can turn the sound effects on or off without disturbing the game. When power is on, press this key to turn off the sound effects. Press it again to restore the sound effects.
- **START/ON**
When power is off, this key is to turn on the power. When power is on, this key is to restart the game.
- **LFLIP**
Press this key to move up two flips on the left of the screen. When it is released, the flips are moved down.
- **RFLIP**
At the beginning of the game, this functions as in serving a ball. When the ball gets into the activity zone, it becomes a right flip which has the same function as LFLIP.

Operational description

There are five levels in this game. Each level has different shifting speed. The higher the level is, the faster is the speed. When START/ON key is pressed, the highest score is shown and the initial level is displayed. Player can press RFLIP to select the level. After that, press START/ON key to start the game. Press RFLIP to serve the ball, when the ball drops, depending on its position press LFLIP or RFLIP to flip the ball and prevent it from dropping to the goal. The strength to serve a ball depends on the length of time allotted in pressing RFLIP key. There is a gate at the bottom left side of the screen. The gate will open or close at intervals. The ball should be prevented from dropping down to the gate when it is open. There are only three balls served in each level. When the score reaches 3000 or 7000, one ball is relatively added as bonus. When power is on, or player has to select a level, or when the game is over, if the player does not press any key at any one of the three conditions, then it automatically goes into free run within one minute. During free run, if START/ON or OFF key is pressed, then the game starts, or the power is off. Otherwise, if the free run lasts about 4 minutes 20 seconds, the power is automatically turned off. The highest score is lost only when RESET key is pressed or when the battery is changed.

- **LCD test pattern**
At any time, press LFLIP or RFLIP key simultaneously with RESET key, then release the RESET key, all the LCD patterns are shown. When LFLIP or RFLIP key is also released, the program goes back to normal.

Counting method

- 10 score is counted when the ball is touched once with left or right flip.
- 10 score is counted when the ball is touched once with the three circles. 30 score is counted if it gets into any one of the circles.
- 30 score is counted when the ball is passing through the left or the right gate.
- 50 score is counted when the ball gets into the two circles located between screen.
- 30 score is counted when the ball gets into the gate at the bottom left.
- When the ball is served, 10 or 20 or 30 score is counted depending on the path it takes to get into the activity zone. The smaller the strength to serve the ball, the lower is the score.

Sound effects

There are 12 kinds of sound effects in this game.

- Power on sound
- Game start
- Sound of serving a ball
- Sound that the ball is touched with circle or right or left flip
- Sound that the ball gets into the circle
- Sound that the ball gets into the rotating circle
- Sound that the ball is shifting
- Sound that the ball is in the hole
- Sound that the ball is passing through the gate
- Sound that the ball is dropping into the goal
- Game over sound
- Sound that the flips flip the ball

LCD Display Label

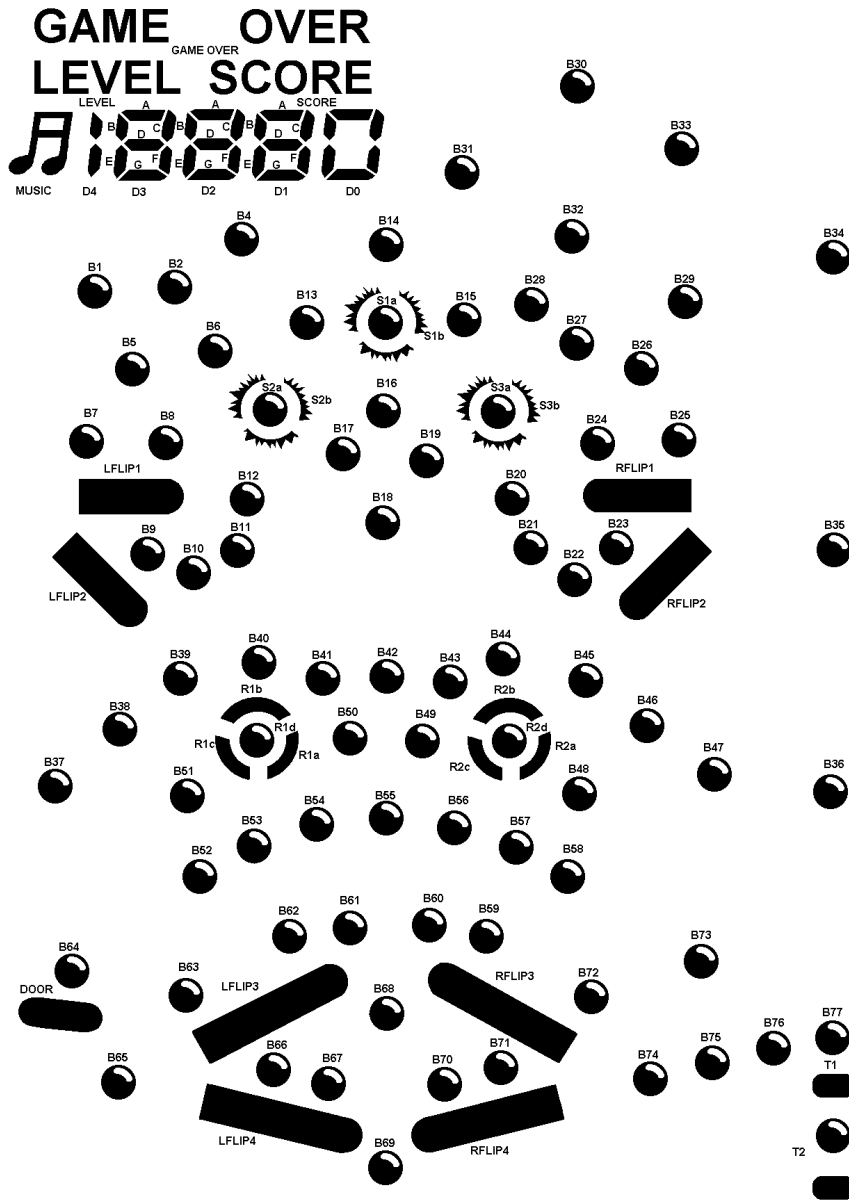

LCD Pattern Contrast Table

Pad No.	Pin No.	COM1	COM2	COM3	COM4	SEGMENT
34	1	GAME OVER	D3C	D3D	D3F	1
35	2	D2A	D2B	D2E	D2G	2
36	3	SCORE	D2C	D2D	D2F	3
37	4	D1A	D1B	D1E	D1G	4
38	5	D0	D1C	D1D	D1F	5
39	6	B14	B4	B2	B1	6
40	7	S1B	B13	B6	B5	7
41	8	S1A	S2B	S2A	B8	8
42	9	B16	B17	B12	B7	9
43	10	B19	B18	B11	LFLIP1	10
44	11	B44	B42	B10	B9	11
45	12	B43	B41	B40	LFLIP2	12
46	13	B49	B50	R1B	B39	13
47	14	B55	R1A	R1D	R1C	14
48	15	B60	B54	B51	B38	15
49	16	B59	B62	B53	B37	16
50	17	RFLIP3	B61	B63	B52	17
51	18	B71	B68	LFLIP3	B64	18
52	19	B70	B67	B66	DOOR	19
53	20	RFLIP4	B69	LFLIP4	B65	20
5	21	—	—	—	COM4	COM4
6	22	—	—	COM3	—	COM3
7	23	—	COM2	—	—	COM2
8	24	COM1	—	—	—	COM1
8	25	COM1	—	—	—	COM1
7	26	—	COM2	—	—	COM2
6	27	—	—	COM3	—	COM3
5	28	—	—	—	COM4	COM4
—	29	—	—	—	—	—
54	30	B76	B77	T1	T2	21

Pad No.	Pin No.	COM1	COM2	COM3	COM4	SEGMENT
55	31	B74	B75	B72	B73	22
56	32	R2C	B56	B57	B58	23
—	33	—	—	—	—	—
57	34	R2D	R2A	B48	B47	24
—	35	—	—	—	—	—
58	36	R2B	B45	B46	B36	25
—	37	—	—	—	—	—
—	38	—	—	—	—	—
—	39	—	—	—	—	—
59	40	B21	B22	RFLIP2	B35	26
60	41	B20	B23	RFLIP1	B25	27
61	42	S3A	B24	B26	B29	28
—	43	—	—	—	—	—
—	44	—	—	—	—	—
62	45	S3B	B28	B27	B34	29
63	46	B15	B32	B30	B33	30
64	47	B31	LEVEL	D4	MUSIC	31
65	48	D3A	D3B	D3E	D3G	32

LCD Package Outline

Unit : mm

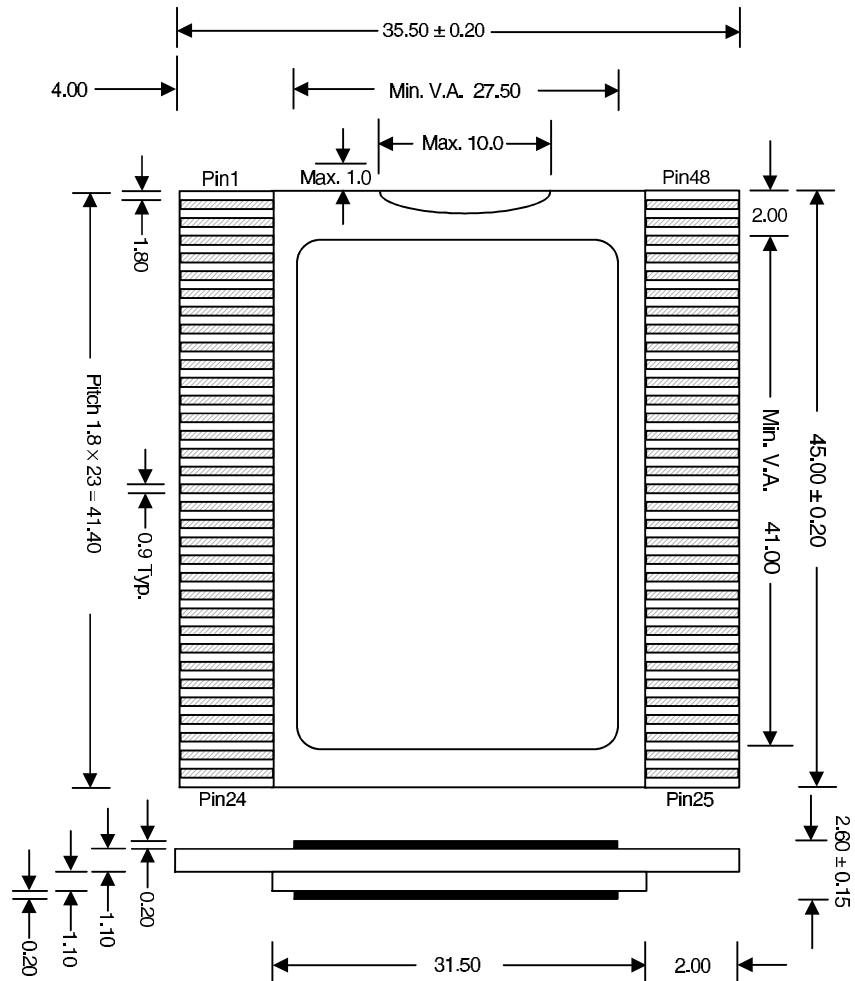

Pad Coordinates

 Unit: μm

Pad No.	X	Y	Pad No.	X	Y
1	-1192.10	1305.20	34	1261.10	-1122.30
2	-1192.10	1169.80	35	1261.10	-979.80
3	-1196.70	1019.80	36	1261.10	-836.30
4	-1261.10	873.70	37	1261.10	-693.80
5	-1261.10	731.20	38	1261.10	-550.30
6	-1261.10	587.70	39	1261.10	-407.80
7	-1261.10	445.20	40	1261.10	-264.30
8	-1261.10	301.70	41	1261.10	-121.80
9	-1261.10	159.20	42	1261.10	21.70
10	-1261.10	15.70	43	1261.10	164.20
11	-1261.10	-126.80	44	1261.10	307.70
12	-1261.10	-270.30	45	1261.10	450.20
13	-1261.10	-412.80	46	1261.10	593.70
14	-1261.10	-556.30	47	1261.10	736.20
15	-1261.10	-698.80	48	1261.10	879.70
16	-1261.10	-842.30	49	1261.10	1022.20
17	-1261.10	-984.80	50	1261.10	1165.70
18	-1261.10	-1128.30	51	1261.10	1311.20
19	-876.70	-1331.40	52	1001.00	1331.40
20	-719.70	-1331.40	53	858.50	1331.40
21	-542.10	-1241.00	54	715.00	1331.40
22	-406.70	-1241.00	55	572.50	1331.40
23	-276.30	-1241.00	56	429.00	1331.40
24	-140.90	-1241.00	57	286.50	1331.40
25	-10.50	-1241.00	58	143.00	1331.40
26	124.90	-1241.00	59	0.50	1331.40
27	284.90	-1331.40	60	-143.00	1331.40
28	427.40	-1331.40	61	-285.50	1331.40
29	570.90	-1331.40	62	-429.00	1331.40
30	713.40	-1331.40	63	-571.50	1331.40
31	856.90	-1331.40	64	-715.00	1331.40
32	999.40	-1331.40	65	-857.50	1331.40
33	1261.10	-1265.80	66	-990.50	1331.40

Absolute Maximum Ratings*

Supply Voltage -0.3V to 5.5V Storage Temperature..... -50°C to 125°C
 Input Voltage..... $V_{SS}-0.3V$ to $V_{DD}+0.3V$ Operating Temperature..... 0°C to 70°C

*Note: These are stress ratings only. Stresses exceeding the range specified under “Absolute Maximum Ratings” may cause substantial damage to the device. Functional operation of this device at other conditions beyond those listed in the specification is not implied and prolonged exposure to extreme conditions may affect device reliability.

Electrical Characteristics

Ta=25°C

Symbol	Parameter	Test Condition		Min.	Typ.	Max.	Unit
		V _{DD}	Condition				
V _{DD}	Operating Voltage	—	—	2.4	3	3.3	V
I _{DD}	Operating Current	3V	No load, f _{SYS} =256kHz	—	250	500	μA
I _{STB}	Standby Current	3V	No load	—	1	5	μA
V _{LCD}	LCD Supply Voltage	3V	—	—	3	—	V
f _{SYS}	Operating Frequency	3V	R=75kΩ	—	256	—	kHz

Application Circuits

Buzzer application

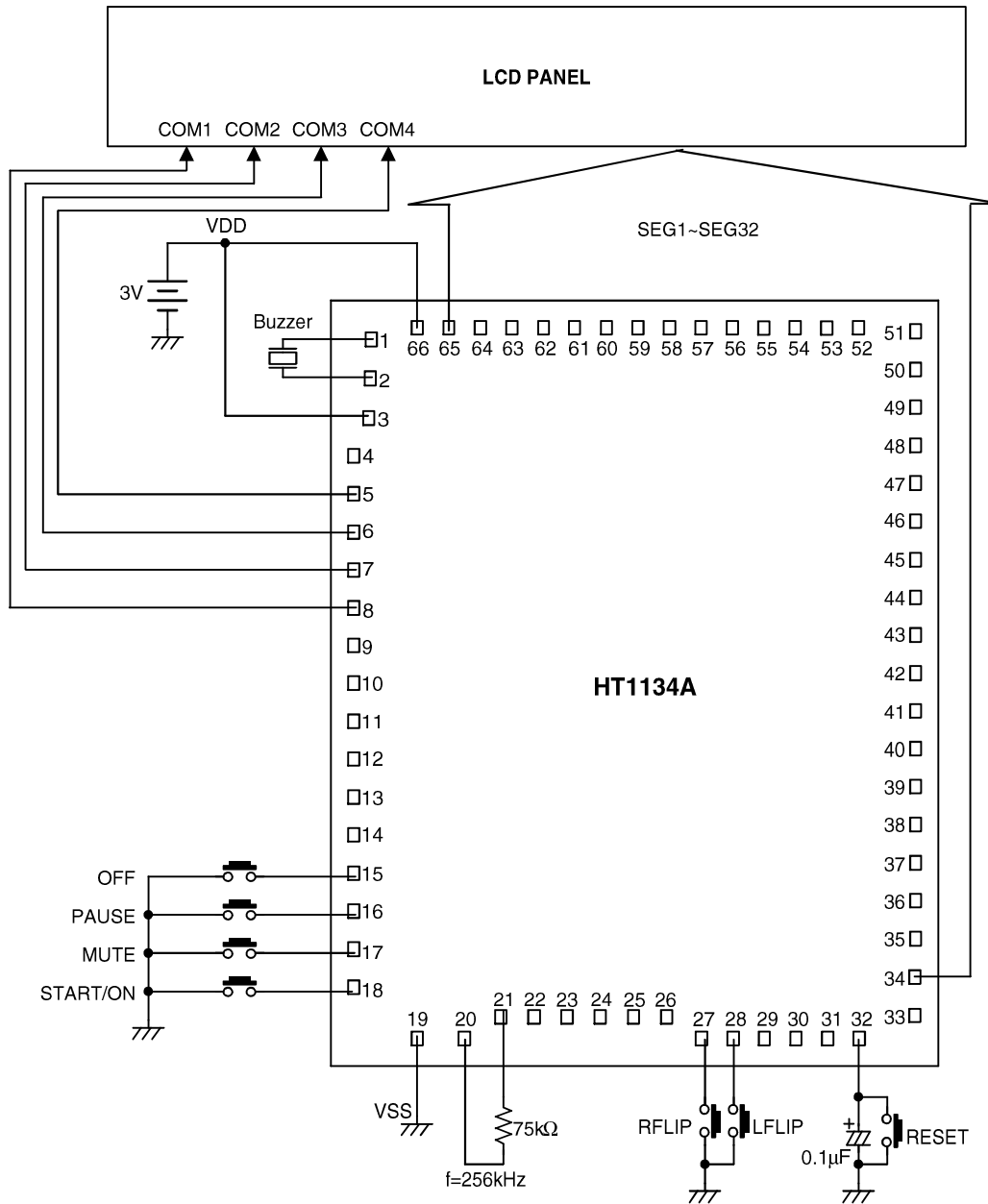

Note: The IC substrate should be connected to VSS in the PCB layout artwork.

Speaker application

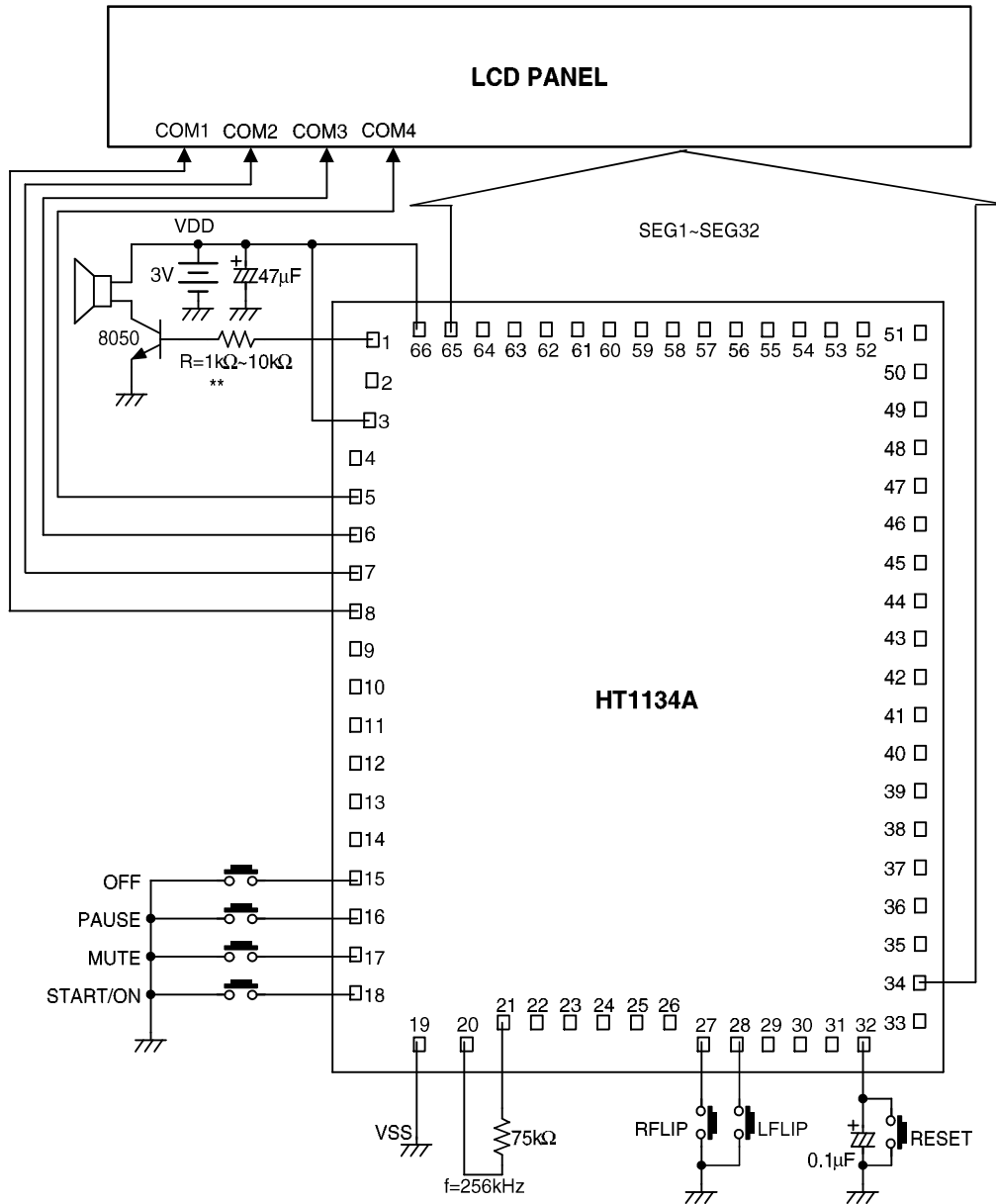

Notes: The IC substrate should be connected to VSS in the PCB layout artwork.

** User can change the volume by changing the resistance 1kΩ~10kΩ.