



"Streetfighters" LCD Game

Features

- 1/3 bias, 1/4 duty, 32 × 4 pattern, 3.0V LCD driver
- 13 different sound effects
- RC oscillator
- Auto power off function

General Description

The HT113AA is a game controller IC designed by Holtek. In this game the player and the enemy or the computer, compete against each

other for the prize. The player can use both kicks and punches in this streetfighting game to attack the enemy.

LCD Pattern



Functional Description

Key description

- **RESET**
This key resets the game and clears any previously recorded score. If the PUNCH and RESET keys are pressed simultaneously and then the RESET key is released while still holding the PUNCH key, all the LCD patterns will be displayed for testing purposes.
- **START/PAUSE**
If the game is in the demonstration mode or at the GAME OVER stage, pressing this key starts the game. If play has commenced, pressing this key temporarily stops the game. If it is pressed again the game continues.
- **MUTE**
This key controls the sound effects. Its toggle action alternately turns the sound on or off.
- **ON/OFF**
This key controls the power supply to the IC. Its toggle action alternately turns the game on or off.
- **↑**
Moves the player up.
- **↓**
Moves the player down.
- **←**
Moves the player to the left.
- **→**
Moves the player to the right.

- **Punch/Mode**
This key serves two functions, one is for punching the opponent and the other is to set the mode of the game. Before the game starts this key can be used to select one of the four playing modes. After the game has started this key is used to enable the player to punch the opponent.
- **Kick**
This key is used to enable the player to kick the opponent.

Operation

- After pressing the ON/OFF switch to turn on the power supply, the game will immediately enter the demonstration mode. The game will demonstrate how the player and enemy figures fight. The highest score will also be displayed. If Punch/Mode is pressed the game mode can be chosen which is then represented by the number of heads shown at the bottom right corner of the screen.
 - ♦ **Mode 1**
One head displayed– one enemy to fight with.
 - ♦ **Mode 2**
Two heads displayed– two enemies to fight with.
 - ♦ **Mode 3**
Three heads and one weapon displayed– three enemies to fight with.
 - ♦ **Mode 4**
No mode indicator is displayed. The game moves from mode 1, mode 2 to mode 3 after each game has been won.

- After selecting the playing mode, pressing the START/PAUSE key will first play the prelude music before the game starts.
- In mode 1 there is only one enemy figure. The player can use the left, right, up and down keys to move the figure to the best position then use the PUNCH or KICK key to attack the enemy.
- If the playing figure is attacked by the enemy figure it will immediately fall down. When this happens the player must press the up key to recover or be subjected to continuous attacks.
- When the enemy's score reaches zero the game objective has been reached and the overall score will be increased by one. Every playing mode has a maximum score of 99. When this has been reached it will remain at this value and not increase any more.
- If the player's score reaches zero, the game will end and the overall score will be recorded. The flashing game over message will be displayed.
- In mode 2, there are two enemies that have to be attacked and destroyed to win the game.
- In mode 3, aside from the two main enemy figures there is an additional enemy figure holding a weapon who can attack the player. The player cannot attack this enemy, and can only dodge out of his way.
- In mode 3 this third enemy figure with the weapon can appear at any time on the top left or right side of the screen. This enemy figure is able to work out the best place to attack the player who must be careful to dodge out of the way.
- Mode 4 combines all the three modes. Starting from mode 1, after the game has been won or the barrier reached, the game will then move to mode 2, then to mode 3.
- The higher the overall score the faster the enemy figure's actions will be.
- In modes 2 and 3, the second enemy figure will attack from behind, so the player must be careful to dodge out of the way.
- The displayed data have the following meaning ...
 - ♦ During the demonstration mode, the playing mode will be displayed at the bottom of the screen and the recorded overall score at the top of the screen. The mode number corresponds to the number of heads displayed.
 - ♦ When the game starts, the overall score will be displayed while the prelude music is playing.
 - ♦ When the game is playing the score of both the player and opponent will be shown. The player's score is displayed at the left while the opponent or enemy's score is displayed at the right. The objective is to reduce the enemy's score to zero.
- If no key has been pressed for 2 minutes then the game will automatically be turned off, however the overall game score will be retained.
- The MUTE switch will silence the sound effects.

- The START/PAUSE key will put the game into a temporary wait state. The conditions of the game prior to pressing this key will be retained even if the game has been switched off manually or automatically. When the game is again started, the player can resume from where it stops when the START/PAUSE key was initially pressed. If the machine is switched off outside of this temporary wait state then the conditions of the present game will not be stored and the game has to start from the beginning.
- When the game is over the message "GAME OVER" will flash on the screen and the game will enter a wait state. Pressing the START/PAUSE key will allow a new game to start or pressing the PUNCH/MODE key will allow a new mode of playing to be chosen. Or press ON/OFF to switch off. If within 30 seconds no key has been pressed the system will begin to free run in the demonstration mode.
- The ON/OFF switch controls the power supply.

Calculating the score

- When the game begins both the player and enemy's score is 9.
- Every punch, kick or weapon hit (mode 3) will initially mean a reduction of the opponent's score by one. But the actual score deducted is dependent upon the opponents score. If the opponents score is 9 then 0.9 will be deducted, if the opponents score is 8 then 0.8 will be deducted and so on in the same way. However due to the limitations of the LCD pattern the decimal number will not be shown.
- If within 7 seconds no attack is made then the score will be increased by one but only up to a maximum of 9. This applies to both player and opponent.
- When the opponent's score has been reduced to 0, the objective of the present game has been reached. When the player's score reaches zero, the game is over.

Sound effects

- The IC has 13 sound effects
 - ♦ Sound corresponding to the mode
 - ♦ When the player is attacked
 - ♦ When the weapon is about to be used
 - ♦ When the weapon is thrown
 - ♦ When the weapon hits the player
 - ♦ When the player kicks
 - ♦ When the player throws a punch
 - ♦ When the enemy kicks
 - ♦ When the enemy throws a punch
 - ♦ When the game objective has been reached
 - ♦ When the game begins
 - ♦ When the game ends
 - ♦ Background sound effect

LCD Display Table

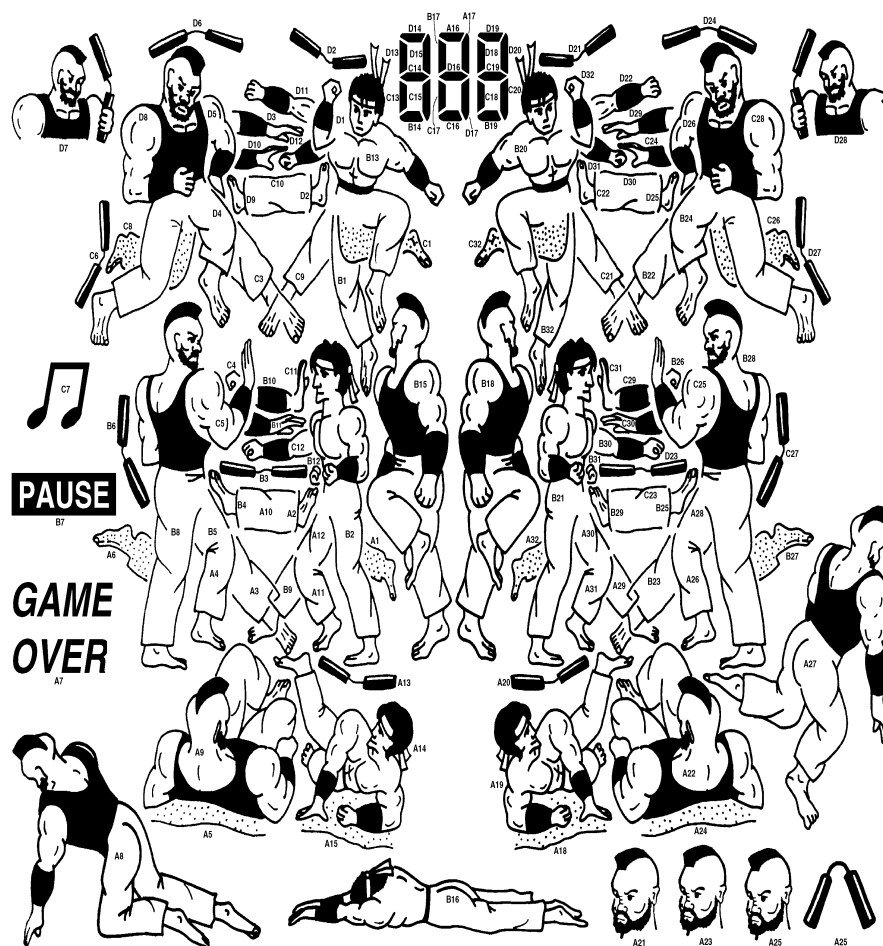

LCD Pattern Contrast Table

Pad No.	Pin No.	COM0	COM1	COM2	COM3	SEGMENT
5	36	—	—	—	COM3	COM3
6	35	—	—	COM2	—	COM2
7	34	—	COM1	—	—	COM1
8	33	COM0	—	—	—	COM0
34	32	A32	B32	C32	D32	SEG0
35	31	A31	B31	C31	D31	SEG1

Pad No.	Pin No.	COM0	COM1	COM2	COM3	SEGMENT
36	30	A30	B30	C30	D30	SEG2
37	29	A29	B29	C29	D29	SEG3
38	28	A28	B28	C28	D28	SEG4
39	27	A27	B27	C27	D27	SEG5
40	26	A26	B26	C26	D26	SEG6
41	25	A25	B25	C25	D25	SEG7
42	24	A24	B24	C24	D24	SEG8
43	23	A23	B23	C23	D23	SEG9
44	22	A22	B22	C22	D22	SEG10
45	21	A21	B21	C21	D21	SEG11
46	20	A20	B20	C20	D20	SEG12
47	19	A19	B19	C19	D19	SEG13
48	18	A18	B18	C18	D18	SEG14
49	17	A17	B17	C17	D17	SEG15
50	16	A16	B16	C16	D16	SEG16
51	15	A15	B15	C15	D15	SEG17
52	14	A14	B14	C14	D14	SEG18
53	13	A13	B13	C13	D13	SEG19
54	12	A12	B12	C12	D12	SEG20
55	11	A11	B11	C11	D11	SEG21
56	10	A10	B10	C10	D10	SEG22
57	9	A9	B9	C9	D9	SEG23
58	8	A8	B8	C8	D8	SEG24
59	7	A7	B7	C7	D7	SEG25
60	6	A6	B6	C6	D6	SEG26
61	5	A5	B5	C5	D5	SEG27
62	4	A4	B4	C4	D4	SEG28
63	3	A3	B3	C3	D3	SEG29
64	2	A2	B2	C2	D2	SEG30
65	1	A1	B1	C1	D1	SEG31

LCD Package Outline

Unit : mm

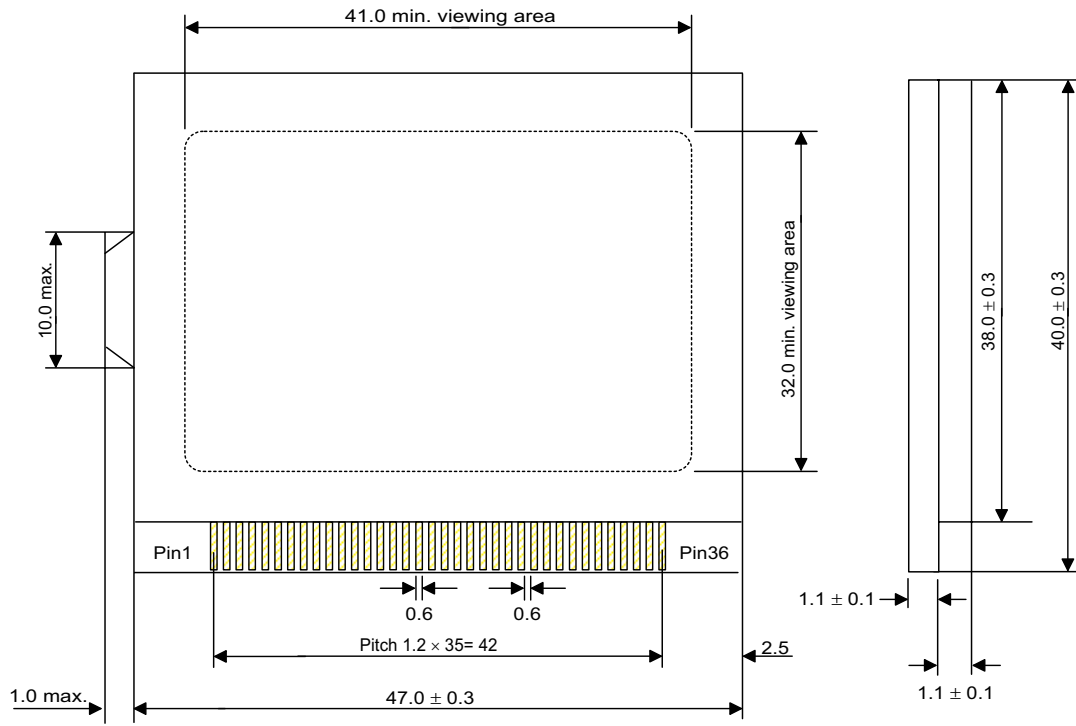

Pad Assignment

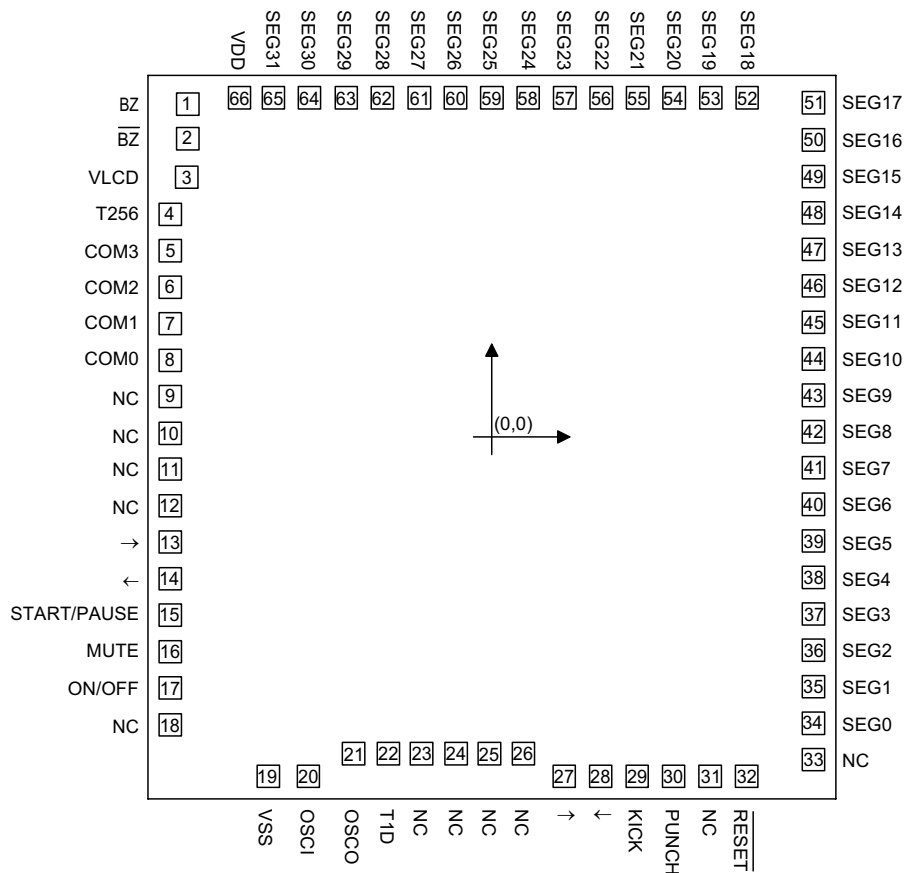

Chip Size : 2780 × 2990 (μm)²

* The IC substrate should be connected to VSS in the PCB layout artwork.

Pad Coordinates

 Unit : μm

Pad No.	X	Y	Pad No.	X	Y
1	-1192.10	1305.20	34	1261.10	-1122.30
2	-1192.10	1169.80	35	1261.10	-979.80
3	-1196.70	1019.80	36	1261.10	-836.30
4	-1261.10	873.70	37	1261.10	-693.80
5	-1261.10	731.20	38	1261.10	-550.30
6	-1261.10	587.70	39	1261.10	-407.80
7	-1261.10	445.20	40	1261.10	-264.30
8	-1261.10	301.70	41	1261.10	-121.80
9	-1261.10	159.20	42	1261.10	21.70
10	-1261.10	15.70	43	1261.10	164.20
11	-1261.10	-126.80	44	1261.10	307.70
12	-1261.10	-270.30	45	1261.10	450.20
13	-1261.10	-412.80	46	1261.10	593.70
14	-1261.10	-556.30	47	1261.10	736.20
15	-1261.10	-698.80	48	1261.10	879.70
16	-1261.10	-842.30	49	1261.10	1022.20
17	-1261.10	-984.80	50	1261.10	1165.70
18	-1261.10	-1128.30	51	1261.10	1311.20
19	-876.70	-1331.40	52	1001.00	1331.40
20	-719.70	-1331.40	53	858.50	1331.40
21	-542.10	-1241.00	54	715.00	1331.40
22	-406.70	-1241.00	55	572.50	1331.40
23	-276.30	-1241.00	56	429.00	1331.40
24	-140.90	-1241.00	57	286.50	1331.40
25	-10.50	-1241.00	58	143.00	1331.40
26	124.90	-1241.00	59	0.50	1331.40
27	284.90	-1331.40	60	-143.00	1331.40
28	427.40	-1331.40	61	-285.50	1331.40
29	570.90	-1331.40	62	-429.00	1331.40
30	713.40	-1331.40	63	-571.50	1331.40
31	856.90	-1331.40	64	-715.00	1331.40
32	999.40	-1331.40	65	-857.50	1331.40
33	1261.10	-1265.80	66	-990.50	1331.40

Absolute Maximum Ratings

Supply Voltage $V_{DD}-0.3V$ to $5.5V$ Storage Temperature..... $-50^{\circ}C$ to $125^{\circ}C$
 Input Voltage $V_{SS}-0.3V$ to $V_{DD}+0.3V$ Operating Temperature $0^{\circ}C$ to $70^{\circ}C$

Note: These are stress ratings only. Stresses exceeding the range specified under "Absolute Maximum Ratings" may cause substantial damage to the device. Functional operation of this device at other conditions beyond those listed in the specification is not implied and prolonged exposure to extreme conditions may affect device reliability.

Electrical Characteristics
 $T_a=25^{\circ}C$

Symbol	Parameter	Test Conditions		Min.	Typ.	Max.	Unit
		V_{DD}	Conditions				
V_{DD}	Operating Voltage	—	—	2.4	3	3.3	V
I_{DD}	Operating Current	3V	No load, $f_{SYS}=512kHz$	—	300	500	μA
I_{STB}	Standby current	3V	system halt	—	1	5	mA
V_{LCD}	LCD Supply Voltage	3V	—	—	3	—	V
f_{SYS}	Operating Frequency	3V	$R=36k\Omega$	—	512	—	kHz

Application Circuits

Buzzer application

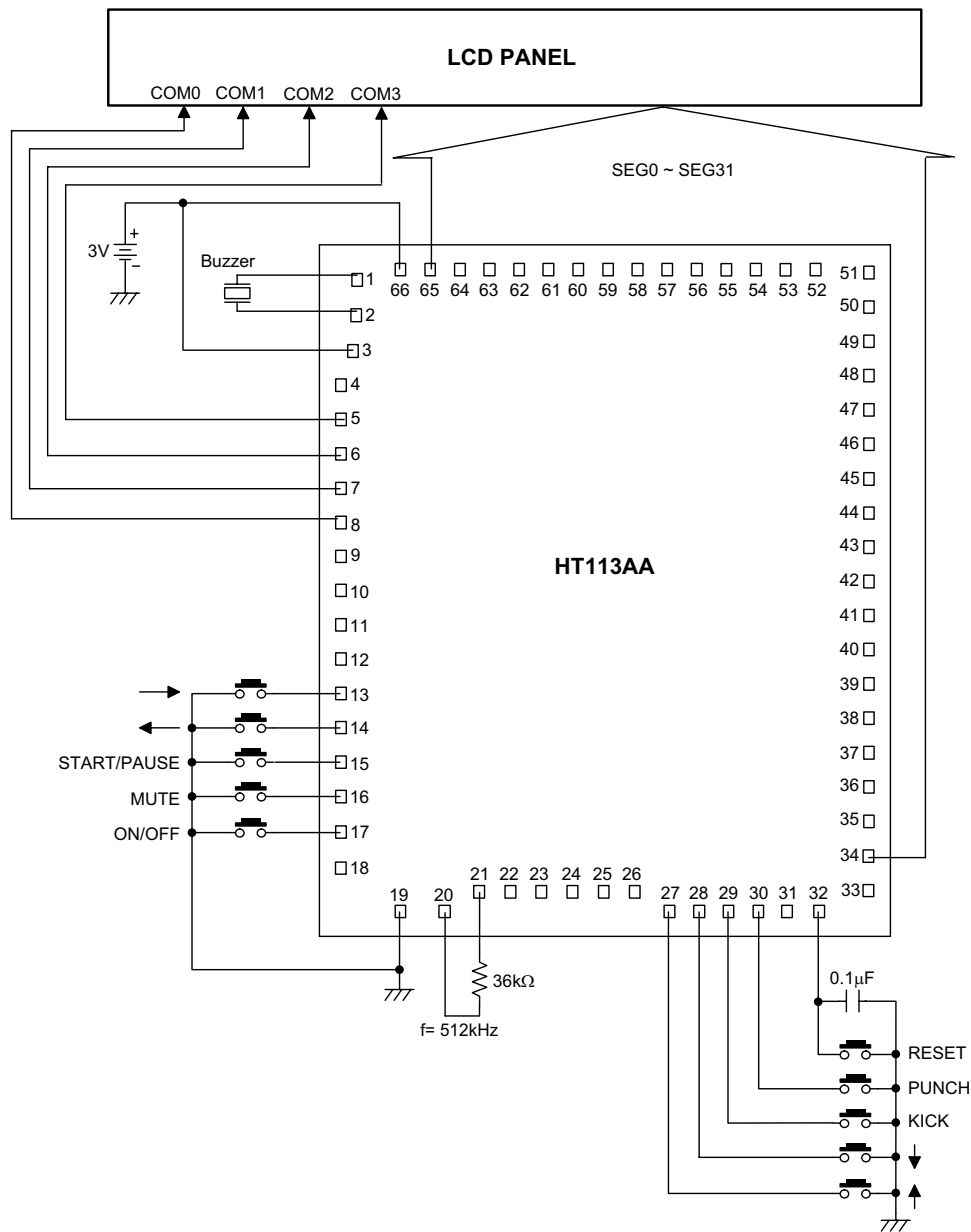

Note: The IC substrate should be connected to VSS in the PCB layout artwork.

Speaker application

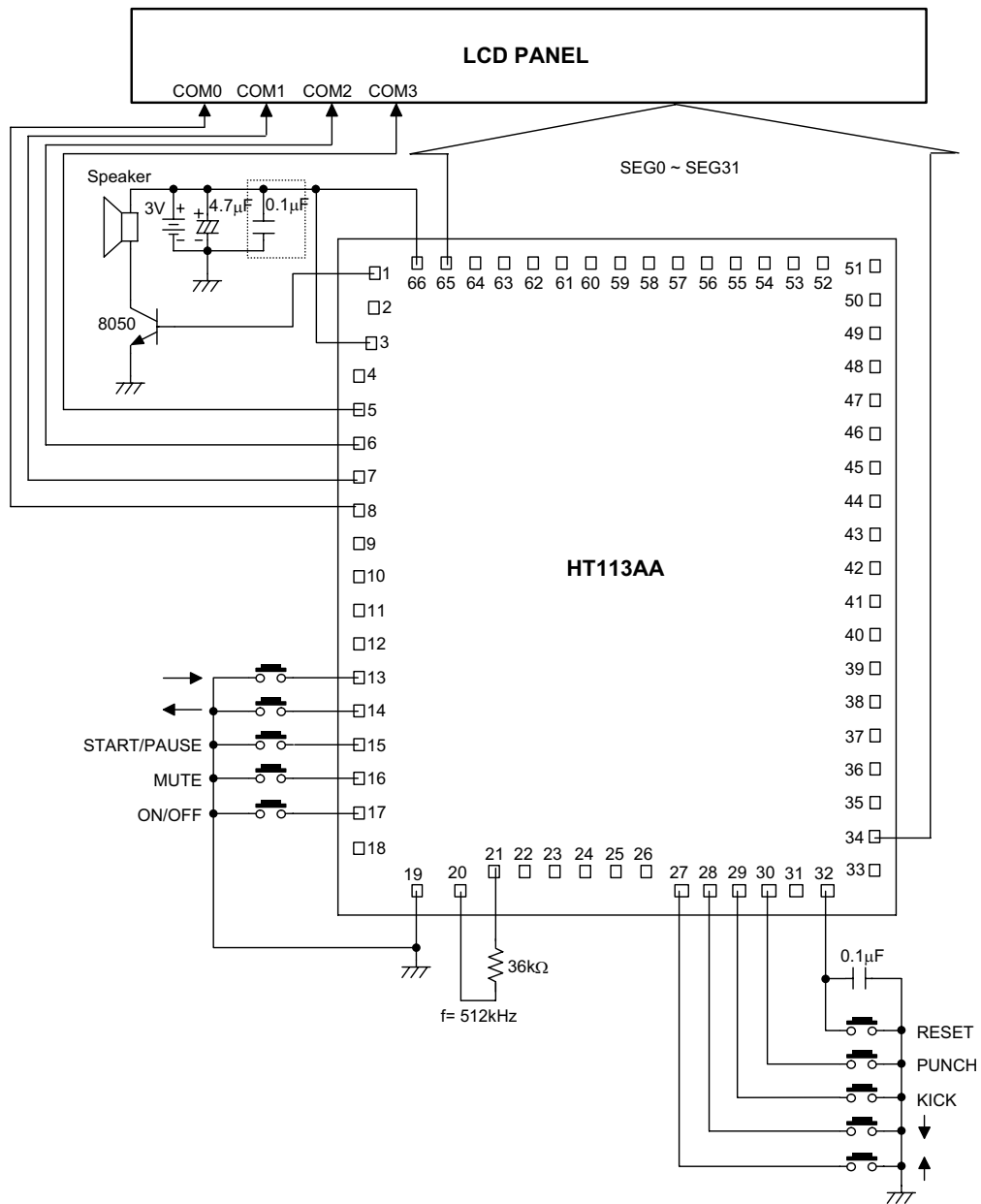

Note: The capacitor in dash block is recommended.

The IC substrate should be connected to VSS in the PCB layout artwork.

Holtek Semiconductor Inc. (Headquarters)

No.3 Creation Rd. II, Science-based Industrial Park, Hsinchu, Taiwan, R.O.C.
Tel: 886-3-563-1999
Fax: 886-3-563-1189

Holtek Semiconductor Inc. (Taipei Office)

5F, No.576, Sec.7 Chung Hsiao E. Rd., Taipei, Taiwan, R.O.C.
Tel: 886-2-2782-9635
Fax: 886-2-2782-9636
Fax: 886-2-2782-7128 (International sales hotline)

Holtek Semiconductor (Hong Kong) Ltd.

RM.711, Tower 2, Cheung Sha Wan Plaza, 833 Cheung Sha Wan Rd., Kowloon, Hong Kong
Tel: 852-2-745-8288
Fax: 852-2-742-8657

Copyright © 1999 by HOLTEK SEMICONDUCTOR INC.

The information appearing in this Data Sheet is believed to be accurate at the time of publication. However, Holtek assumes no responsibility arising from the use of the specifications described. The applications mentioned herein are used solely for the purpose of illustration and Holtek makes no warranty or representation that such applications will be suitable without further modification, nor recommends the use of its products for application that may present a risk to human life due to malfunction or otherwise. Holtek reserves the right to alter its products without prior notification. For the most up-to-date information, please visit our web site at <http://www.holtek.com.tw>.