



**Casino Game 5-in-1 LCD Game**

**Features**

- 1/3 bias, 1/4 duty, 32x4 pattern, 3.0V LCD driver
- Built-in sound generator
- RC oscillator
- Auto power off mode

**General Description**

HT113SA is a mini-casino LCD game designed by HOLTEK. The HT113SA consists of five

games namely, Poker, Black Jack, Baccarat, Slots and Deuces.

**LCD Pattern**

 **WIN**  
**BLACK JACK**  
**POKER**  
**DOUBLE SPLIT**  
**INSURANCE**  
**DRAW or HOLD**

<b>DEALER</b>		<b>PLAYER</b>		
\$	8	8	8	8
<b>HOLD</b>	<b>HOLD</b>	<b>HOLD</b>	<b>HOLD</b>	<b>HOLD</b>



## Functional Description

### Key description

- **RESET**

When this key is pressed, the whole system restarts, the score and game round are cleared to zero. When the RESET key and ON/OFF key are pressed at the same time, and then the RESET key is released, all the pattern dots are shown on the screen. This function is for LCD testing.

- **ON/OFF**

This key is used to turn the power on. When pressed again, the power is turned off.

- **MUTE**

This key alternately puts the music in the OFF or ON modes.

- **GAME**

This key is for game selection. There are five games to be selected, namely Black Jack, Poker, Baccarat, Deuces and Slots. When this key is pressed, one of SEL1~SEL5 is displayed on the screen.

SEL1 denotes that Black Jack is selected.

SEL2 denotes that Poker is selected.

SEL3 denotes that Baccarat is selected.

SEL4 denotes that Deuces is selected.

SEL5 denotes that Slot Machine is selected.

The game is initially set with Black Jack as default whenever the system is activated.

- **START/DEAL**

This key is used to start a game or to deal the cards. When it is in the DEMO mode, pressing this key starts a game. On the other hand, when the game is in progress, it deals the cards.

- **KEY1~KEY5**

	when betting	POKER	B&J	BACCARAT	SLOTS	DEUCES
KEY1		HOLD1	INSURANCE	TIE		HOLD1
KEY2		HOLD2		DEALER		HOLD2
KEY3		HOLD3	DOUBLE	PLAYER		HOLD3
KEY4	BET_D	HOLD4	STAND	BET_D	BET_D	HOLD4
KEY5	BET_U	HOLD5		BET_U	BET_U	HOLD5

- **When betting**

- **DEAL**

When this key is pressed, the bets must have already been made. The cards then start to be dealt. At this time, if the player fails to press BET\_U or BET\_D, pressing DEAL may restore his/her previous bet, which is pre-set to 1.

- **BET\_U**

By pressing this key, the screen changes to display the bets in place of the current stake. However, pressing this key will increase the betting score by 1 (100 is the maximum) when the bets are already on the screen.

- **BET\_D**

By pressing this key, the screen changes to display the bets in place of the current stake. However, pressing this key will decrease the betting score by 1 (1 is the minimum) when the bets are already on the screen.

- **By pressing this key, the screen changes to display the bets in place of the current stake. However, pressing this key will decrease the betting score by 1 (1 is the minimum score) when the bets are already on the screen.**

- **BLACK JACK GAME**

- **DEAL**

This key is pressed to deal the cards.

- **STAND**

This key is pressed to stop card-dealing.

- **INSURANCE**

This key is pressed to select INSURANCE.

- **DOUBLE**

This key is pressed to select DOUBLE.

\* Refer to the Black Jack game description for the conditions in 3 and 4.

- **POKER GAME**

- **DEAL**

After selecting which cards to bet on, pressing this key begins re-dealing the cards to

the unselected positions (see the following for the selection).

- **HOLD1~HOLD5**

These keys are used to reserve the cards. HOLD1 (KEY1) is situated at the leftmost side, and HOLD5 at the rightmost side. In that order, KEY1~KEY5 are arranged from left to right to correspond with the LCD pad.

- **BACCARAT GAME**

- **DEAL**

This key is pressed to deal the cards.

- **PLAYER**

(PLAY) This key is pressed to bet on the player.

- **DEALER**

(BANK) This key is pressed to bet on the dealer.

- **TIE**

(PUSH) This key is pressed to bet on a tie.

- **DEUCES GAME**

- **DEAL**

After selecting which cards to bet on, pressing this key begins re-dealing the cards to the unselected positions (see the following for the selection).

- **HOLD1~HOLD5**

These keys are used to reserve the cards. HOLD1 (KEY1) is situated at the leftmost side, and HOLD5 at the rightmost side. In that order, KEY1~KEY5 is arranged from left to right to correspond with the LCD pad.

- **SLOTS GAME**

- **DEAL**

This key is pressed to spin the pictures.

### Operational description

- Right after the batteries are installed, the system goes into the DEMO mode. The pre-set game is BLACK JACK. By pressing the START key, the game begins. And the money to gamble with amounts to 2000 units. However, if activity has been suspended for more than 2 minutes, power is automatically turned off. To turn on the power, press the

ON/OFF key. The player can continue playing. The mode remains the same as that before turning off the power. In other words, if the power is turned off in the DEMO mode, this mode is on the screen when the power is turned on again.

- The betting strategies are in the following: First, the money to gamble with is displayed and the symbol \$ flashes on the screen. Then, by pressing BET\_U (KEY5) or BET\_D (KEY4), the previous bets are shown. The bet is incremented by 1 when the BET\_U (KEY5) key is subsequently pressed. On the other hand, the bet is decremented by 1 when the BET\_D (KEY4) is subsequently pressed. After the bets have been made, press the DEAL key to start dealing the cards. However, if the player fails to press the BET\_U or BET\_D key, pressing the DEAL key restores the bet to the previous one. The bet is pre-set to 1 if it is the first time the bet is laid.

- **BLACK JACK**

- Black Jack is one of the most common games in casinos. The rules for this game are quite easy. The player wins when his/her total score is greater than the dealer's. However, the player loses the game when his/her total score is over 21.

- The values of the cards 2 to 10 are scored according to their corresponding face values. As for the cards J, Q, K, their values are all scored as 10. The value of the card ACE can be scored either as 1 or 11 depending on the player's preference.

- After the bets are made, the dealer and player are dealt with 2 cards each on the first deal. The dealer's first card is covered. So, the player can only see the dealer's second card. The following explains two conditions which may then appear:

- **INSURANCE**

- When the dealer's second card is an ACE, it is quite possible that the dealer will win Black Jack. In this case, the player may pay the equivalent of his/her present bet to buy insurance. The dealer, if he wins Black Jack, will refund all the bets to the

player. If not, the dealer will confiscate the insurance. And the game continues.

- **DOUBLE**

When the total value of the player's two cards sum up to 11, (s)he may lay the bet on one-more-card-dealt-only. However, the player needs to double his/her present bet. Such a bet is for the player's sake, since (s)he is quite likely to get the full score of 21 and win the Black Jack game by holding a score of 11. As long as the total value of his/her three cards is greater than that of the dealer's, the player wins the game and gains the bet two times larger than his/hers.

When one or possibly two of the above conditions take place, the exact symbol, namely INSURANCE or DOUBLE, will flash. At this time, the player has the choice of one or none of these conditions. However, the player is not advised to bet if his/her money to gamble with is not sufficient for that bet.

- If there is no special case, pressing the DEAL key deals the cards. However, when the STAND (KEY4) key is pressed, no more cards can be dealt. The dealer can then deal additional cards to himself. The rules are quite easy. The dealer is required to deal himself another card if the sum of his current cards is less than 17. Otherwise, if the sum is 17 or greater, he is not required to deal himself any more cards.

- The various betting rates of loss are listed in the following:

BLACK JACK (a score of 21 for two cards).....2

A score of less than 21 for 5 cards.....1  
 the player's score is greater than the dealer's.....1

• **POKER (SHOW HAND)**

- After the bets have been made, five cards are dealt by pressing the DEAL key. At this time, DRAW or HOLD flashes. Below each card is a HOLD symbol. The player may keep the desired cards by pressing the appropriate number of keys up to five keys.

When the cards are highlighted, it indicates that these cards are to be reserved for betting. Otherwise, cards are to be re-dealt by pressing the DEAL key. On the basis of the five cards, the betting rates for losing are calculated in the following ways:

- pair (jacks or better)  
1 times the number of units betted
- two pairs  
2 times the number of units betted
- three of a kind  
3 times the number of units betted
- straight  
5 times the number of units betted
- flush  
8 times the number of units betted
- full house  
35 times the number of units betted
- four of a kind  
100 times the number of units betted
- straight flush  
500 times the number of units betted
- royal flush  
1000 times the number of units betted

• **BACCARAT**

This game is an ancient card game that originates from Europe. Baccarat consists of three ways of betting, namely DEALER, PLAYER, and TIE. However, only one of the three betting ways can be selected at a time. After the bets have been made, four cards are dealt. The first and third cards are dealt to the player whereas the second and fourth cards to the dealer. The aim of this game is to make the total value of the two cards sum up to 9 or as near as possible to 9. The value of the card ACE is scored as 1. The values of the cards 2-9 are scored according to their corresponding face values. As for the cards 10, J, Q, and K, their values are all scored as 0. No more cards can be dealt when the sum of the two cards is 8 or 9, which is called NATURAL. However, a third card can be dealt if necessary. The rule for the order of card-dealing is always the

player first. The following explains the rules for dealing the third card:

♦ Player

- 1-2-3-4-5-0  
the third card is dealt
- 6,7  
no cards are to be dealt
- 8-9  
NATURAL

♦ Dealer

When the player holds two cards only, the third card is dealt to the dealer when the sum of his two cards is 0~5, and the sum of the player's is 6 or 7. However, no more cards are dealt to the dealer when the total value of his/her two cards is 6~9.

When the player holds three cards, no more cards are dealt to the dealer when the sum of his two cards is 6, 7 or 8. Otherwise, the third card can be dealt to the dealer. Win or lose is decided by the total value of the cards held. The winner's score is the one nearest 9. As for the betting rate of losing, it is 1 times the number of the units betted (i.e., 1 x (Number of Units)).

If the scores of the dealer's and player's are the same, it is called a "TIE". At this time, the one who bets on TIE is the winner. The betting rate of losing is 8 times the number of units betted.

When selecting the way to bet on, the screen displays the following:

When DEALER is betted on, BANK is shown.

When TIE is betted on, PUSH is shown.

When PLAYER is betted on, PLAY is shown.

♦ DEUCES

♦ After the bets have been made, five cards are dealt by pressing the DEAL key. Below each card is a HOLD symbol. The player may keep the desired cards by pressing the appropriate number of keys up to five keys. When the cards are highlighted, it indicates that these cards are to be reserved for betting. Otherwise, cards are to be re-dealt by pressing the DEAL key. When the value of one of the cards is 2, that "2" can be any number ranging from a~k depending on the player's preference, and then on the basis of the five cards, the rates for winning and losing are calculated in the following ways:

- three of a kind  
2 times the number of units betted
- straight  
4 times the number of units betted
- flush  
6 times the number of units betted
- full house  
10 times the number of units betted
- 4 of a kind  
10 times the number of units betted
- straight flush  
20 times the number of units betted
- 5 of a kind  
50 times the number of units betted
- royal flush w/2's  
100 times the number of units betted
- 4 deuces  
500 times the number of units betted
- royal flush  
1000 times the number of units betted

• SLOTS

- After the bets have been made, pressing the DEAL key starts a game. The numbers 'a', 'g', 'd' on the LCD screen simulate the 'BAR' spinning. Right after the three numbers stop spinning, the scores won are calculated in the following ways:

			Betting Rates of Loss
BAR BAR BAR	BAR BAR BAR	BAR BAR BAR	500
BAR BAR	BAR BAR	BAR BAR	50
BAR	BAR	BAR	10
ANY BAR	ANY BAR	ANY BAR	2

- To change the game type, press the GAME key. At this time, the money to gamble with remains the same as in the previous deal.

**Counting methods**

- The betting rates of lose for BLACK JACK  
BLACK JACK.....2  
the sum of 5 cards less than 21.....1  
the sum of the player's is greater than that of the dealer's.....1
- the betting rates of winning for POKER
  - pair (jacks or better)  
1 times the number of units betted
  - two pairs  
2 times the number of units betted
  - three of a kind  
3 times the number of units betted
  - straight  
5 times the number of units betted

- flush  
8 times the number of units betted
- full house  
35 times the number of units betted
- four of a kind  
100 times the number of units betted
- straight flush  
500 times the number of units betted
- royal flush  
1000 times the number of units betted

• BACCARAT

- When the bet is on the dealer or the player, the betting rate of losing is 1 times the number of units betted.
- When the bet is on TIE, the betting rate of losing is 8 times the number of units betted.

• The betting rates of winning for DEUCES

- three of a kind  
2 times the number of units betted
- straight  
4 times the number of units betted
- flush  
6 times the number of units betted
- full house  
10 times the number of units betted
- 4 of a kind  
10 times the number of units betted
- straight flush  
20 times the number of units betted
- 5 of a kind  
50 times the number of units betted
- royal flush w/2's  
100 times the number of units betted
- 4 deuces  
500 times the number of units betted
- royal flush  
1000 times the number of units betted

- The betting rates of losing for SLOTS

			<b>Betting Rates of Loss</b>
BAR BAR BAR	BAR BAR BAR	BAR BAR BAR	500
BAR BAR	BAR BAR	BAR BAR	50
BAR	BAR	BAR	10
ANY BAR	ANY BAR	ANY BAR	2

- When the money to gamble with reaches 999999, no more scores can be added.

**Sound effects**

- Sounds when the cards are dealt
- Sound for prompting the user to press the keys
- Music for winning a score

- Sound for POKER J PAIR or BETTER prompting
- Sound when the wrong key is pressed
- Sound for shuffling
- Music when the score is BLACK JACK
- Sound for losing BLACK JACK
- Music for winning BLACK JACK
- Sound for losing POKER
- Music for winning POKER
- Music for game start
- Music for game over
- Sound when SLOT MACHINE is spun

**Voice sound effects (coupled with the external HT8125B speech IC)**

- Sound for shuffling
- Sound for dealing
- Sound when the money is put in
- Sound for money dropping
- Sound for losing
- Sound for winning

LCD Display Label

M <sup>WIN</sup> **WIN**  
**BLACK JACK** <sup>BJ</sup>  
**POKER** <sup>PO</sup>  
**DOUBLE** <sup>DO</sup> **SPLIT** <sup>SP</sup>  
**INSURANCE** <sup>IN</sup>  
**DRAW or HOLD** <sup>DH</sup>

<sup>DE</sup> **DEALER** <sup>PL</sup> **PLAYER**

<sup>S</sup> \$ **00** **00** **00** **00** **00** **00**  
D1 D2 D3 D4 D5 D6

<sup>A1</sup> <sup>A2</sup> <sup>A3</sup> <sup>A4</sup> <sup>A5</sup> <sup>A6</sup> <sup>A7</sup> <sup>A8</sup> <sup>A9</sup> <sup>A10</sup>  
**10** **10** **10** **10** **10**  
E1 E2 E3 E4 E5  
**HOLD** **HOLD** **HOLD** **HOLD** **HOLD**  
H1 H2 H3 H4 H5

T1 T2 T3 T4 T5

**LCD Pattern Contrast Table**

<b>Pad No.</b>	<b>Pin No.</b>	<b>COM0</b>	<b>COM1</b>	<b>COM2</b>	<b>COM3</b>	<b>SEGMENT</b>
52	1	D7D	D7H	D7G	D7A	SEG18
53	2	B2	D7C	D7B	A2	SEG19
54	3	H2	B3	E2	A3	SEG20
55	4	D8D	D8H	D8G	D8A	SEG21
56	5	B4	D8C	D8B	A4	SEG22
57	6	H3	B5	E3	A5	SEG23
58	7	D9D	D9H	D9G	D9A	SEG24
59	8	B6	D9C	D9B	A6	SEG25
60	9	D2E	D2G	D2F	D2D	SEG26
61	10	H4	B7	E4	A7	SEG27
62	11	D10D	D10H	D10G	D10A	SEG28
63	12	B8	D10C	D10B	A8	SEG29
64	13	H5	B9	E5	A9	SEG30
65	14	D11D	D11H	D11G	D11A	SEG31
8	15	COM0	—	—	—	COM0
7	16	—	COM1	—	—	COM1
6	17	—	—	COM2	—	COM2
5	18	—	—	—	COM3	COM3
34	19	B10	D11C	D11B	A10	SEG0
35	20	D10E	D11E	D11F	D10F	SEG1
36	21	D6E	D6G	D6F	D6D	SEG2
37	22	D6C	D6B	D6A	T5	SEG3
38	23	D5C	D5B	D5A	PL	SEG4
39	24	D5E	D5G	D5F	D5D	SEG5
40	25	D4C	D4B	D4A	T4	SEG6
41	26	D4E	D4G	D4F	D4D	SEG7
42	27	D3C	D3B	D3A	T3	SEG8
43	28	D3E	D3G	D3F	D3D	SEG9
44	29	D2C	D2B	D2A	T2	SEG10
45	30	D1C	D1B	D1A	DE	SEG11
46	31	D1E	D1G	D1F	D1D	SEG12
47	32	S	D9E	D9F	T1	SEG13
48	33	WIN	D8E	D8F	SP	SEG14
49	34	M	BJ	P0	DO	SEG15
50	35	IN	D7E	D7F	DH	SEG16
51	36	H1	B1	E1	A1	SEG17

**LCD Package Outline**

Unit : mm

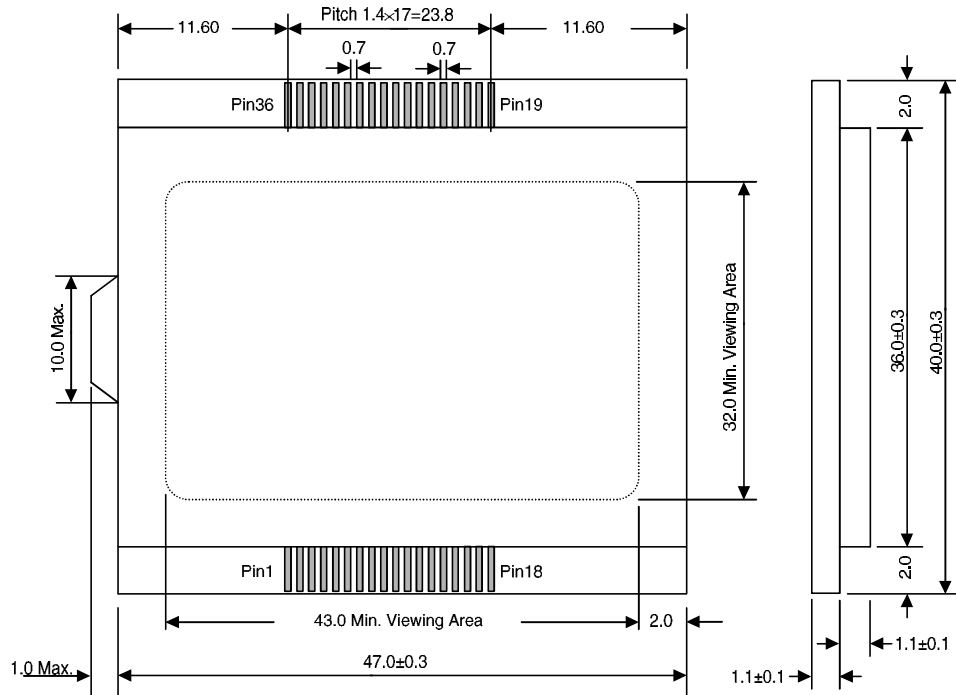
**Specifications:**

Top polarizer: Transmissive (46.00mm×39.00mm)

Bottom polarizer: Transmissive (46.00mm×35.00mm)

Storage temperature: -20°C to 70°C

Operating temperature: -10°C to 60°C

Viewing angle: 6 o'clock

Drive condition: 3V, 1/4 duty, 1/3 bias

Display mode: Tn, positive mode

**Pad Assignment**

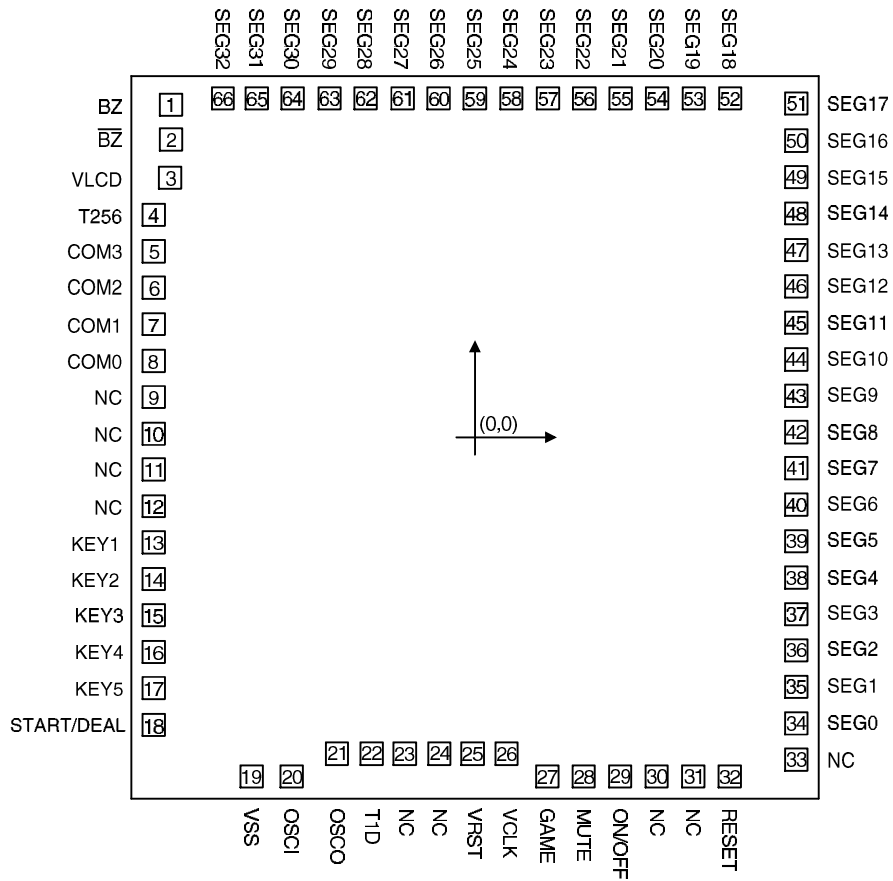

Chip size : 2780 × 2990 (μm)<sup>2</sup>

\* The IC substrate should be connected to VSS in the PCB layout artwork.

**Pad Coordinates**

 Unit :  $\mu\text{m}$ 

<b>Pad No.</b>	<b>X</b>	<b>Y</b>	<b>Pad No.</b>	<b>X</b>	<b>Y</b>
1	-1192.10	1305.20	34	1261.10	-1122.30
2	-1192.10	1169.80	35	1261.10	-979.80
3	-1196.70	1019.80	36	1261.10	-836.30
4	-1261.10	873.70	37	1261.10	-693.80
5	-1261.10	731.20	38	1261.10	-550.30
6	-1261.10	587.70	39	1261.10	-407.80
7	-1261.10	445.20	40	1261.10	-264.30
8	-1261.10	301.70	41	1261.10	-121.80
9	-1261.10	159.20	42	1261.10	21.70
10	-1261.10	15.70	43	1261.10	164.20
11	-1261.10	-126.80	44	1261.10	307.70
12	-1261.10	-270.30	45	1261.10	450.20
13	-1261.10	-412.80	46	1261.10	593.70
14	-1261.10	-556.30	47	1261.10	736.20
15	-1261.10	-698.80	48	1261.10	879.70
16	-1261.10	-842.30	49	1261.10	1022.20
17	-1261.10	-984.80	50	1261.10	1165.70
18	-1261.10	-1128.30	51	1261.10	1311.20
19	-876.70	-1331.40	52	1001.00	1331.40
20	-719.70	-1331.40	53	858.50	1331.40
21	-542.10	-1241.00	54	715.00	1331.40
22	-406.70	-1241.00	55	572.50	1331.40
23	-276.30	-1241.00	56	429.00	1331.40
24	-140.90	-1241.00	57	286.50	1331.40
25	-10.50	-1241.00	58	143.00	1331.40
26	124.90	-1241.00	59	0.50	1331.40
27	284.90	-1331.40	60	-143.00	1331.40
28	427.40	-1331.40	61	-285.50	1331.40
29	570.90	-1331.40	62	-429.00	1331.40
30	713.40	-1331.40	63	-571.50	1331.40
31	856.90	-1331.40	64	-715.00	1331.40
32	999.40	-1331.40	65	-857.50	1331.40
33	1261.10	-1265.80	66	-990.50	1331.40

**Absolute Maximum Ratings\***

Supply Voltage .....  $V_{DD}-0.3V$  to  $5.5V$       Input Voltage.....  $V_{SS}-0.3V$  to  $V_{DD}+0.3V$   
 Storage Temperature.....  $-50^{\circ}C$  to  $125^{\circ}C$       Operating Temperature.....  $0^{\circ}C$  to  $70^{\circ}C$

\*Note: These are stress ratings only. Stresses exceeding the range specified under “Absolute Maximum Ratings” may cause substantial damage to the device. Functional operation of this device at other conditions beyond those listed in the specification is not implied and prolonged exposure to extreme conditions may affect device reliability.

**Electrical Characteristics**
 $T_a=25^{\circ}C$ 

Symbol	Parameter	Test Conditions		Min.	Typ.	Max.	Unit
		$V_{DD}$	Conditions				
$V_{DD}$	Operating Voltage	—	—	2.4	3	3.3	V
$I_{DD}$	Operating Current	3V	No load, $f_{SYS}=512kHz$	—	300	500	$\mu A$
$I_{STB}$	Standby Current	3V	System halt	—	1	5	$\mu A$
$V_{LCD}$	LCD Supply Voltage	3V	—	—	3	—	V
$f_{SYS}$	Operating Frequency	3V	$R=36k\Omega$	—	512	—	kHz

Application Circuits

Speaker application with voice

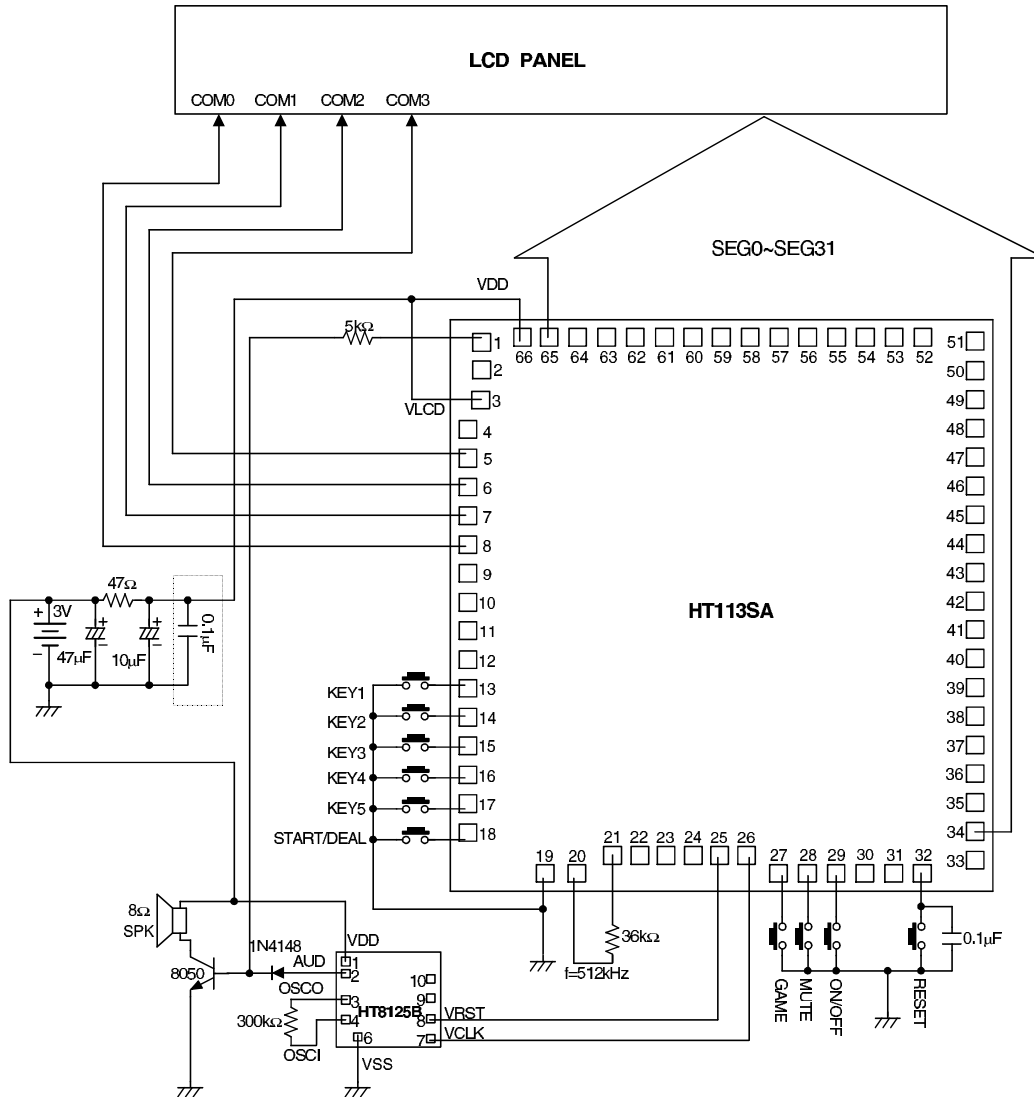

Notes: The capacitor in dash block is recommended.

The IC substrate should be connected to VSS in the PCB layout artwork.

**Speaker application without voice**

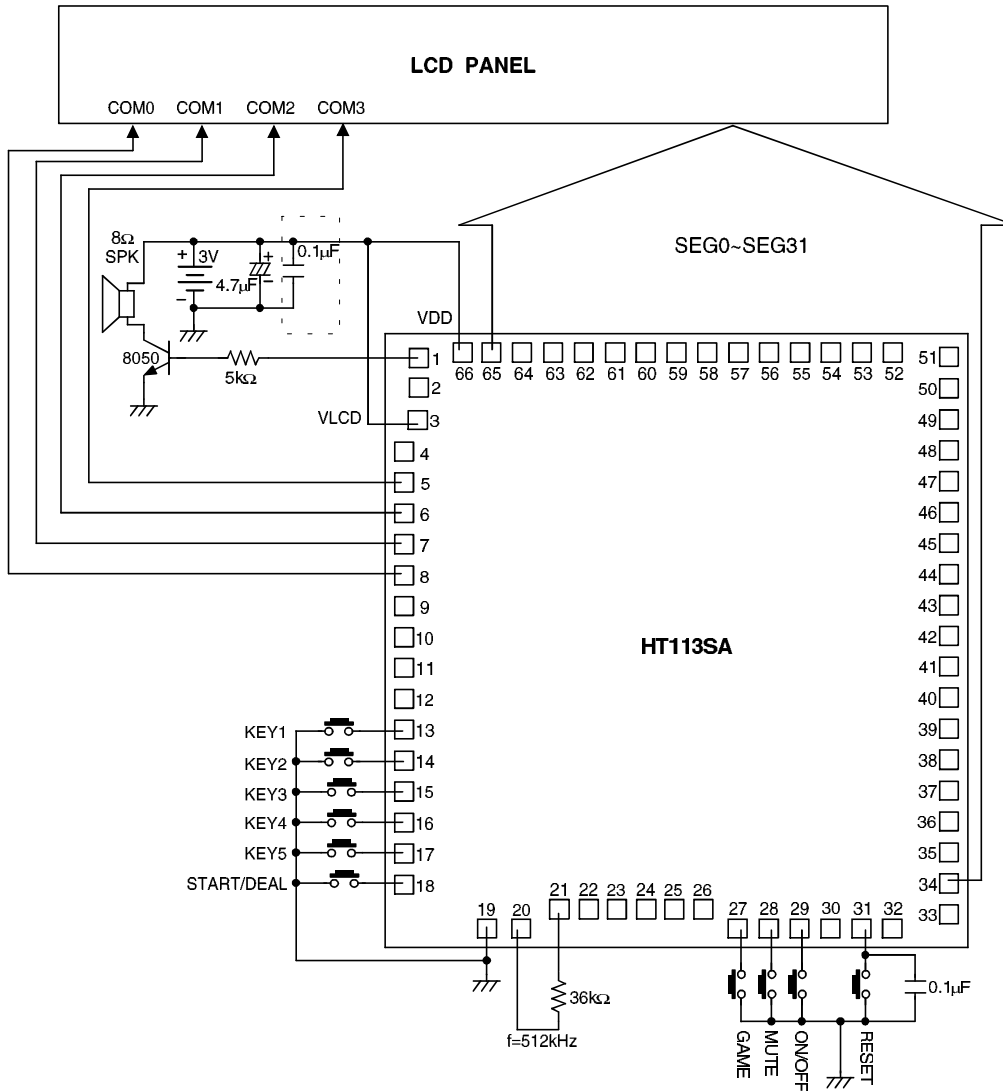

Notes: The capacitor in dash block is recommended.

The IC substrate should be connected to VSS in the PCB layout artwork.

Buzzer application without voice

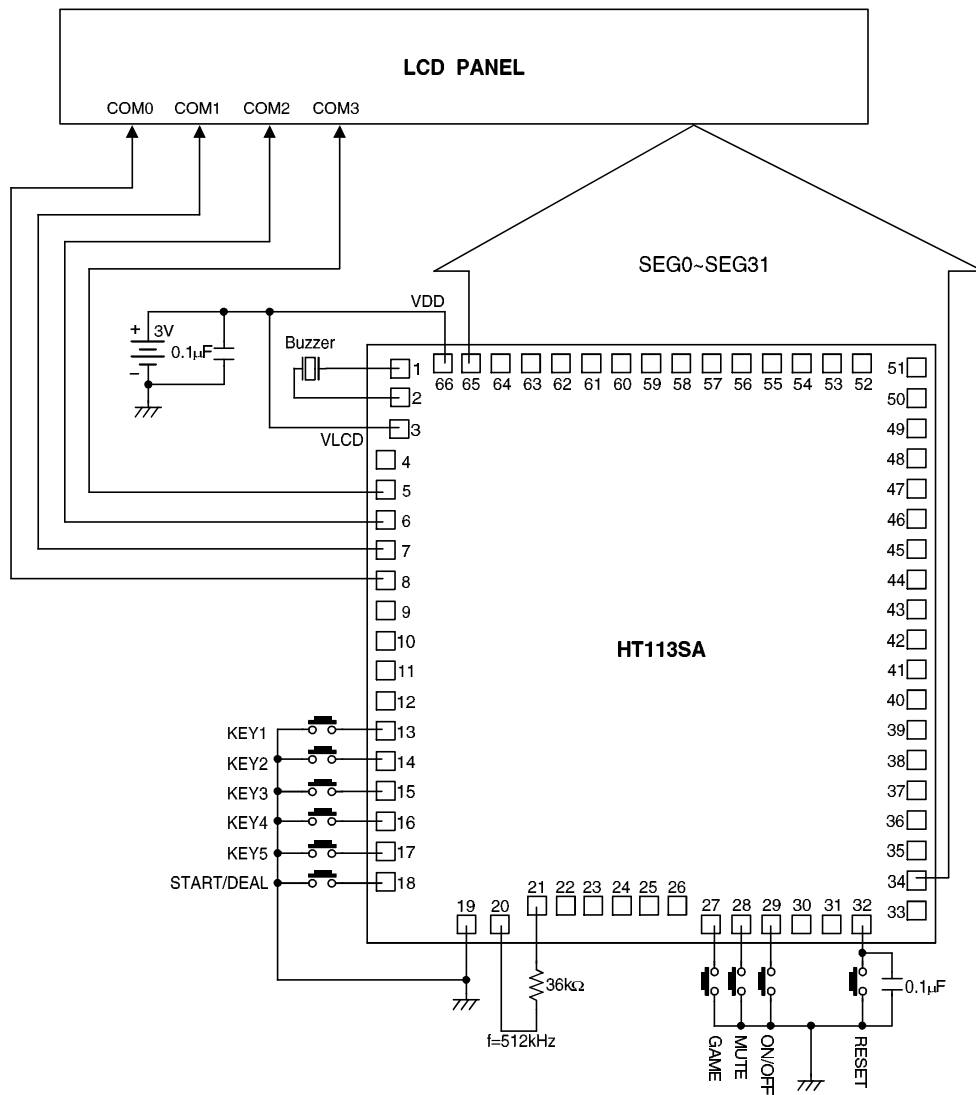

Note: The IC substrate should be connected to VSS in the PCB layout artwork.