



HT1626

RAM Mapping 48×16 LCD Controller for I/O μC

Features

- Operating voltage: 2.7V~5.2V
- Built-in RC oscillator
- External 32.768kHz crystal or 32kHz frequency source input
- 1/5 bias, 1/16 duty, frame frequency is 64Hz
- Max. 48×16 patterns, 16 commons, 48 segments
- Built-in internal resistor type bias generator
- 3-wire serial interface
- 8 kinds of time base/WDT selection
- Time base or WDT overflow output
- Built-in LCD display RAM
- R/W address auto increment
- Two selection buzzer frequencies (2kHz/4kHz)
- Power down command reduces power consumption
- Software configuration feature
- Data mode and Command mode instructions
- Three data accessing modes
- VLCD pin to adjust LCD operating voltage
- Cascade application

General Description

HT1626 is a peripheral device specially designed for I/O type μC used to expand the display capability. The max. display segment of the device are 768 patterns (48×16). It also supports serial interface, buzzer sound, Watchdog Timer or time base timer functions. The HT1626 is a memory mapping and multi-function LCD controller. The software

configuration feature of the HT1626 make it suitable for multiple LCD applications including LCD modules and display subsystems. Only three lines are required for the interface between the host controller and the HT1626. The HT162X series have many kinds of products that match various applications.

Selection Table

HT162X	HT1620	HT1621	HT1622	HT16220	HT1623	HT1625	HT1626	HT1627	HT16270
COM	4	4	8	8	8	8	16	16	16
SEG	32	32	32	32	48	64	48	64	64
Built-in Osc.		√	√		√	√	√	√	
Crystal Osc.	√	√		√	√	√	√		√



Block Diagram

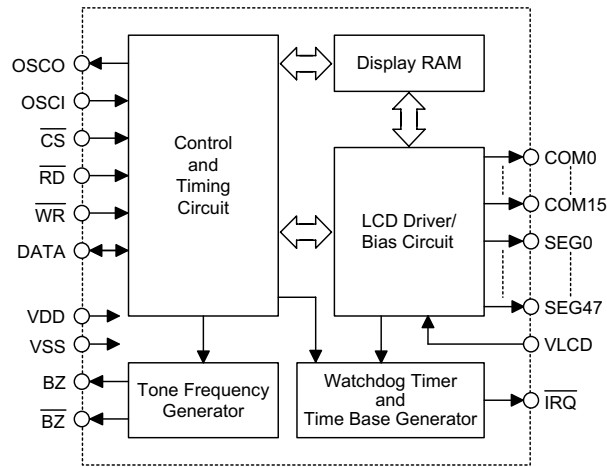

Pin Assignment

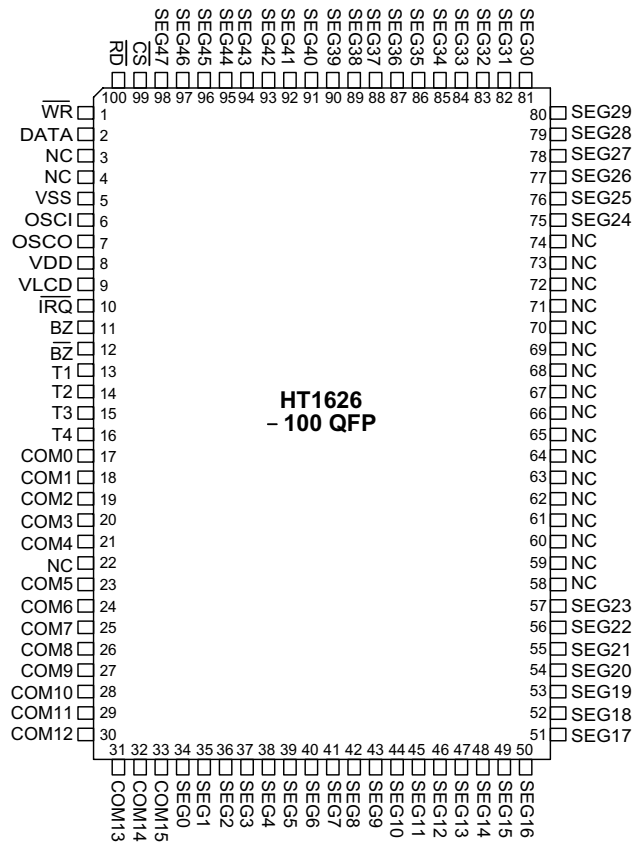

Pad Assignment

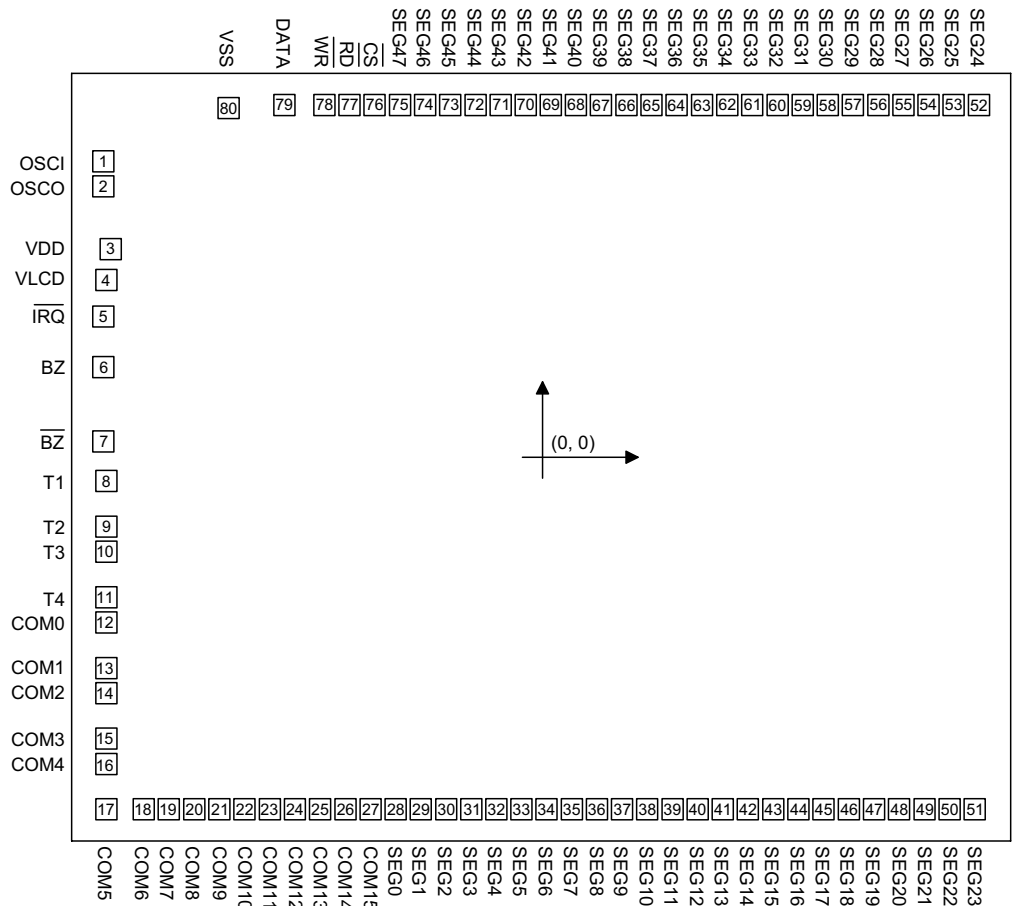

Chip size: $242 \times 196 \text{ (mil)}^2$

* The IC substrate should be connected to VDD in the PCB layout artwork.

Pad Coordinates

Unit: mil

Pad No.	X	Y	Pad No.	X	Y
1	-115.68	77.99	41	47.47	-92.74
2	-115.68	71.36	42	54.10	-92.74
3	-113.69	54.83	43	60.73	-92.74
4	-114.92	46.62	44	67.36	-92.74
5	-115.68	37.10	45	73.99	-92.74
6	-115.68	23.80	46	80.62	-92.74
7	-115.68	4.21	47	87.25	-92.74
8	-114.92	-6.29	48	93.88	-92.74
9	-114.92	-18.27	49	100.51	-92.74
10	-114.92	-24.91	50	107.14	-92.74
11	-114.92	-36.89	51	113.77	-92.74
12	-114.92	-43.52	52	114.88	92.74
13	-114.92	-55.51	53	108.25	92.74
14	-114.92	-62.13	54	101.62	92.74
15	-114.92	-74.12	55	94.99	92.74
16	-114.92	-80.75	56	88.36	92.74
17	-114.92	-92.74	57	81.73	92.74
18	-105.02	-92.74	58	75.10	92.74
19	-98.39	-92.74	59	68.47	92.74
20	-91.76	-92.74	60	61.84	92.74
21	-85.13	-92.74	61	55.21	92.74
22	-78.50	-92.74	62	48.58	92.74
23	-71.87	-92.74	63	41.95	92.74
24	-65.24	-92.74	64	35.32	92.74
25	-58.61	-92.74	65	28.69	92.74
26	-51.98	-92.74	66	22.06	92.74
27	-45.35	-92.74	67	15.43	92.74
28	-38.72	-92.74	68	8.80	92.74
29	-32.09	-92.74	69	2.17	92.74
30	-25.46	-92.74	70	-4.46	92.74
31	-18.83	-92.74	71	-11.09	92.74
32	-12.20	-92.74	72	-17.72	92.74
33	-5.57	-92.74	73	-24.35	92.74
34	1.06	-92.74	74	-30.98	92.74
35	7.69	-92.74	75	-37.61	92.74
36	14.32	-92.74	76	-44.24	92.74
37	20.95	-92.74	77	-50.87	92.74
38	27.58	-92.74	78	-57.50	92.74
39	34.21	-92.74	79	-68.04	92.74
40	40.84	-92.74	80	-82.71	91.97

Pad Description

Pad No.	Pad Name	I/O	Description
1	OSCI	I	The OSCI and OSCO pads are connected to a 32.768kHz crystal in order to generate a system clock. If the system clock comes from an external clock source, the external clock source should be connected to the OSCI pad. But if an on-chip RC oscillator is selected instead, the OSCI and OSCO pads can be left open.
2	OSCO	O	
3	VDD	—	Positive power supply
4	VLCD	I	LCD operating voltage input pad.
5	$\overline{\text{IRQ}}$	O	Time base or Watchdog Timer overflow flag, NMOS open drain output
6, 7	BZ, $\overline{\text{BZ}}$	O	2kHz or 4kHz tone frequency output pair
8~11	T1~T4	I	Not connected
12~27	COM0~COM15	O	LCD common outputs
28~75	SEG0~SEG47	O	LCD segment outputs
76	$\overline{\text{CS}}$	I	Chip selection input with pull-high resistor. When the $\overline{\text{CS}}$ is logic high, the data and command read from or write to the HT1626 are disabled. The serial interface circuit is also reset. But if the $\overline{\text{CS}}$ is at logic low level and is input to the $\overline{\text{CS}}$ pad, the data and command transmission between the host controller and the HT1626 are all enabled.
77	$\overline{\text{RD}}$	I	READ clock input with pull-high resistor. Data in the RAM of the HT1626 are clocked out on the rising edge of the $\overline{\text{RD}}$ signal. The clocked out data will appear on the data line. The host controller can use the next falling edge to latch the clocked out data.
78	$\overline{\text{WR}}$	I	WRITE clock input with pull-high resistor. Data on the DATA line are latched into the HT1626 on the rising edge of the $\overline{\text{WR}}$ signal.
79	DATA	I/O	Serial data input/output with pull-high resistor
80	VSS	—	Negative power supply, Ground

Absolute Maximum Ratings

Supply Voltage.....	-0.3V to 5.5V	Storage Temperature.....	-50°C to 125°C
Input Voltage.....	$V_{SS}-0.3V$ to $V_{DD}+0.3V$	Operating Temperature	-25°C to 75°C

Note: These are stress ratings only. Stresses exceeding the range specified under "Absolute Maximum Ratings" may cause substantial damage to the device. Functional operation of this device at other conditions beyond those listed in the specification is not implied and prolonged exposure to extreme conditions may affect device reliability.

D.C. Characteristics

Ta=25°C

Symbol	Parameter	Test Conditions		Min.	Typ.	Max.	Unit
		V _{DD}	Conditions				
V _{DD}	Operating Voltage	—	—	2.7	—	5.2	V
I _{DD1}	Operating Current	3V	No load/LCD ON	—	155	310	μA
		5V	On-chip RC oscillator	—	260	420	μA
I _{DD2}	Operating Current	3V	No load/LCD ON	—	150	310	μA
		5V	Crystal oscillator	—	250	420	μA
I _{DD11}	Operating Current	3V	No load/LCD OFF	—	8	30	μA
		5V	On-chip RC oscillator	—	20	60	μA
I _{DD22}	Operating Current	3V	No load/LCD OFF	—	—	20	μA
		5V	Crystal oscillator	—	—	35	μA
I _{STB}	Standby Current	3V	No load	—	1	12	μA
		5V	Power down mode	—	2	24	μA
V _{IL}	Input Low Voltage	3V	DATA, $\overline{\text{WR}}$, $\overline{\text{CS}}$, $\overline{\text{RD}}$	0	—	0.6	V
		5V		0	—	1.0	V
V _{IH}	Input High Voltage	3V	DATA, $\overline{\text{WR}}$, $\overline{\text{CS}}$, $\overline{\text{RD}}$	2.4	—	3	V
		5V		4.0	—	5	V
I _{OL1}	BZ, $\overline{\text{BZ}}$, $\overline{\text{IRQ}}$	3V	V _{OL} =0.3V	0.9	1.8	—	mA
		5V	V _{OL} =0.5V	1.7	3	—	mA
I _{OH1}	BZ, $\overline{\text{BZ}}$	3V	V _{OH} =2.7V	-0.9	-1.8	—	mA
		5V	V _{OH} =4.5V	-1.7	-3	—	mA
I _{OL1}	DATA	3V	V _{OL} =0.3V	0.9	1.8	—	mA
		5V	V _{OL} =0.5V	1.7	3	—	mA
I _{OH1}	DATA	3V	V _{OH} =2.7V	-0.9	-1.8	—	mA
		5V	V _{OH} =4.5V	-1.7	-3	—	mA
I _{OL2}	LCD Common Sink Current	3V	V _{OL} =0.3V	80	160	—	μA
		5V	V _{OL} =0.5V	180	360	—	μA
I _{OH2}	LCD Common Source Current	3V	V _{OH} =2.7V	-40	-80	—	μA
		5V	V _{OH} =4.5V	-90	-180	—	μA
I _{OL3}	LCD Segment Sink Current	3V	V _{OL} =0.3V	50	100	—	μA
		5V	V _{OL} =0.5V	120	240	—	μA
I _{OH3}	LCD Segment Source Current	3V	V _{OH} =2.7V	-30	-60	—	μA
		5V	V _{OH} =4.5V	-70	-140	—	μA
R _{PH}	Pull-high Resistor	3V	DATA, $\overline{\text{WR}}$, $\overline{\text{CS}}$, $\overline{\text{RD}}$	100	200	300	kΩ
		5V		50	100	150	kΩ

A.C. Characteristics

Ta=25°C

Symbol	Parameter	Test Conditions		Min.	Typ.	Max.	Unit
		V _{DD}	Conditions				
f _{SYS1}	System Clock	3V	On-chip RC oscillator	22	32	40	kHz
		5V		24	32	40	
f _{SYS2}	System Clock	3V	External clock source	—	32	—	kHz
		5V		—	32	—	
f _{LCD1}	LCD Frame Frequency	3V	On-chip RC oscillator	44	64	80	Hz
		5V		48	64	80	
f _{LCD2}	LCD Frame Frequency	3V	External clock source	—	64	—	Hz
		5V		—	64	—	
t _{COM}	LCD Common Period	—	n: Number of COM	—	n/f _{LCD}	—	sec
f _{CLK1}	Serial Data Clock (\overline{WR} Pin)	3V	Duty cycle 50%	—	—	150	kHz
		5V		—	—	300	
f _{CLK2}	Serial Data Clock (\overline{RD} Pin)	3V	Duty cycle 50%	—	—	75	kHz
		5V		—	—	150	
t _{CS}	Serial Interface Reset Pulse Width (Figure 3)	—	\overline{CS}	—	250	—	ns
t _{CLK}	\overline{WR} , \overline{RD} Input Pulse Width (Figure 1)	3V	Write mode	3.34	—	—	μs
			Read mode	6.67	—	—	
		5V	Write mode	1.67	—	—	μs
			Read mode	3.34	—	—	
t _r , t _f	Rise/Fall Time Serial Data Clock Width (Figure 1)	3V	—	—	120	—	ns
		5V					
t _{su}	Setup Time for DATA to \overline{WR} , \overline{RD} Clock Width (Figure 2)	3V	—	—	120	—	ns
		5V					
t _h	Hold Time for DATA to \overline{WR} , \overline{RD} Clock Width (Figure 2)	3V	—	—	120	—	ns
		5V					
t _{su1}	Setup Time for \overline{CS} to \overline{WR} , \overline{RD} Clock Width (Figure 3)	3V	—	—	100	—	ns
		5V					
t _{h1}	Hold Time for \overline{CS} to \overline{WR} , \overline{RD} Clock Width (Figure 3)	3V	—	—	100	—	ns
		5V					

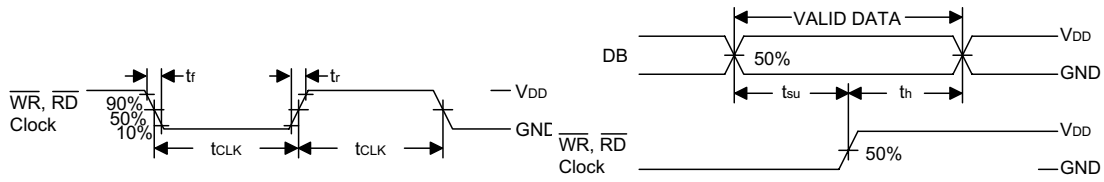

Figure 1

Figure 2

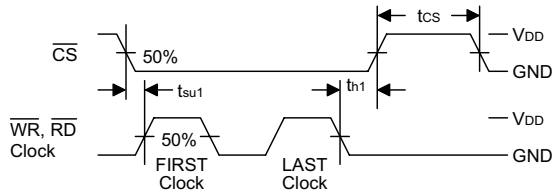

Figure 3

Functional Description

Display memory – RAM structure

The static display RAM is organized into 192x4 bits and stores the display data. The contents of the RAM are directly mapped to the contents of the LCD driver. Data in the RAM can be accessed by the READ, WRITE and READ-MODIFY-WRITE commands. The following is a mapping from the RAM to the LCD patterns.

Time base and Watchdog Timer – WDT

The time base generator and WDT share the same divided (/256) counter. TIMER DIS/EN/CLR, WDT DIS/EN/CLR and $\overline{\text{IRQ}}$ EN/DIS are independent from each other. Once the WDT time-out occurs, the $\overline{\text{IRQ}}$ pin will remain at logic low level until the CLR WDT or the $\overline{\text{IRQ}}$ DIS command is issued.

	COM15	COM14	COM13	COM12	COM3	COM2	COM1	COM0	
SEG0					3					0
SEG1					7					4
SEG2					11					8
SEG3					15					12
.....				
SEG47					191					188
	D3	D2	D1	D0	Addr Data	D3	D2	D1	D0	Addr Data

Data 4 Bits
(D3, D2, D1, D0)

Address 8 Bits
(A7, A6,, A0)

RAM mapping

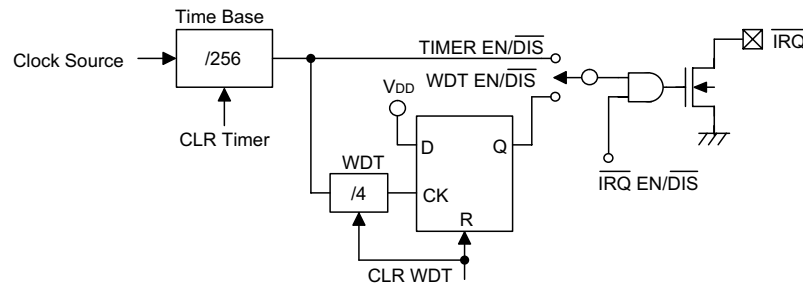

Timer and WDT configurations

If an external clock is selected as the source of system frequency, the SYS DIS command turns out invalid and the power down mode fails to be carried out until the external clock source is removed.

Buzzer tone output

A simple tone generator is implemented in the HT1626. The tone generator can output a pair of differential driving signals on the BZ and \overline{BZ} which are used to generate a single tone.

Command format

The HT1626 can be configured by the software setting. There are two mode commands to configure the HT1626 resource and to transfer the LCD display data.

The following are the data mode ID and the command mode ID:

Operation	Mode	ID
READ	Data	1 1 0
WRITE	Data	1 0 1
READ-MODIFY-WRITE	Data	1 0 1
COMMAND	Command	1 0 0

If successive commands have been issued, the command mode ID can be omitted. While the system is operating in the non-successive command or the non-successive address data mode, the \overline{CS} pin should be set to "1", and the previous operation mode will be reset also. The \overline{CS} pin returns to "0", a new operation mode ID should be issued first.

Name	Command Code	Function
TONE OFF	0000-1000-X	Turn-off tone output
TONE 4K	010X-XXXX-X	Turn-on tone output, tone frequency is 4kHz
TONE 2K	0110-XXXX-X	Turn-on tone output, tone frequency is 2kHz

Timing Diagrams

READ mode (command code : 1 1 0)

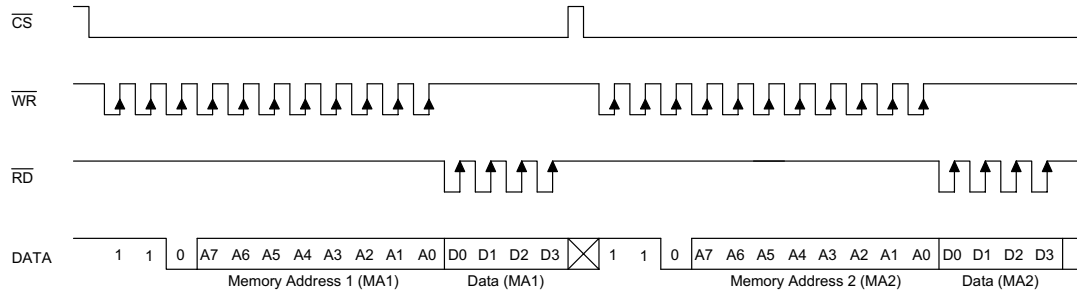

READ mode (successive address reading)

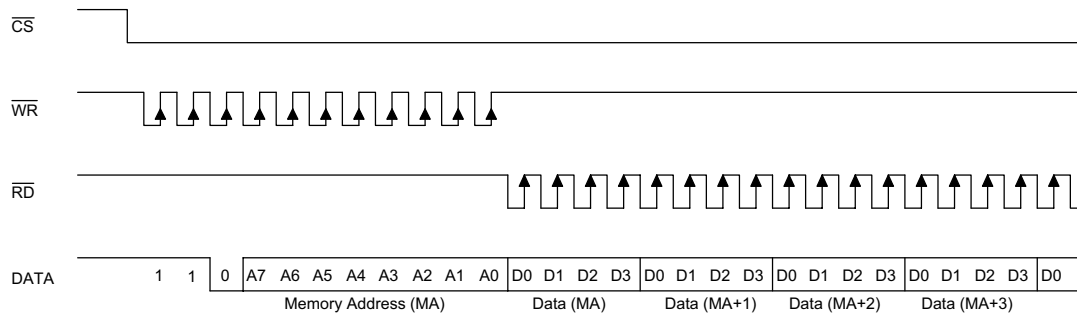

WRITE mode (command code : 1 0 1)

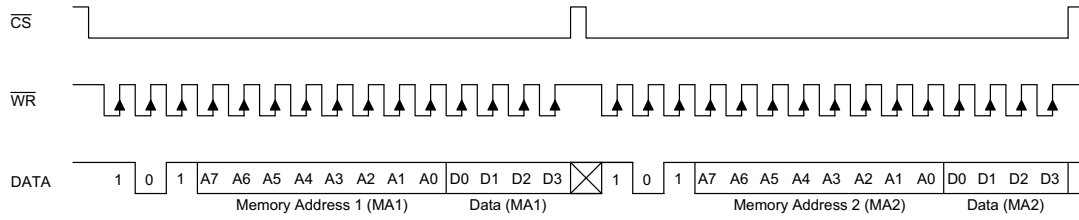

WRITE mode (successive address writing)

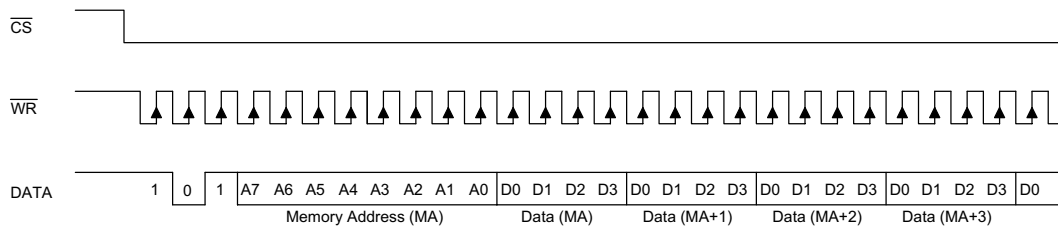

READ-MODIFY-WRITE mode (command code : 1 0 1)

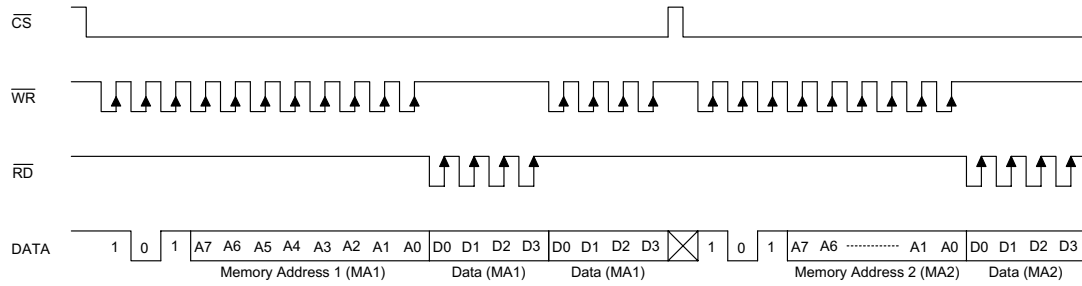

READ-MODIFY-WRITE mode (successive address accessing)

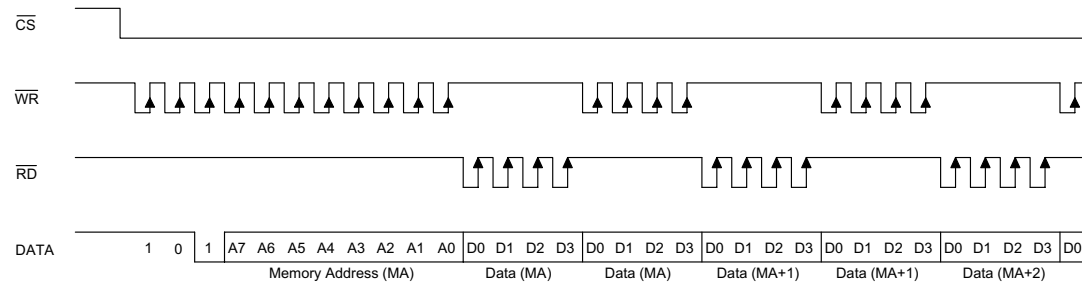

Command mode (command code : 1 0 0)

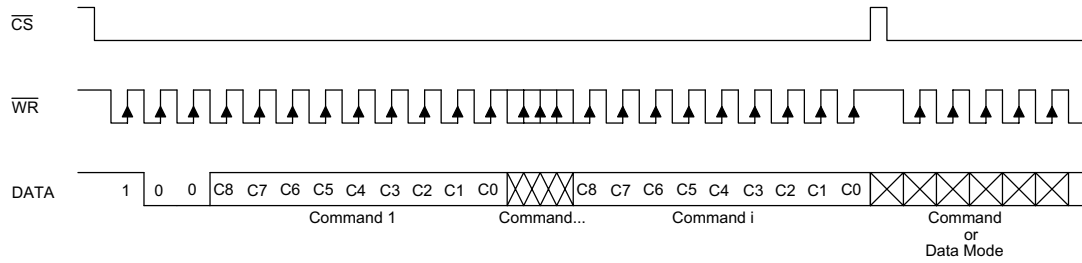

Mode (data and command mode)

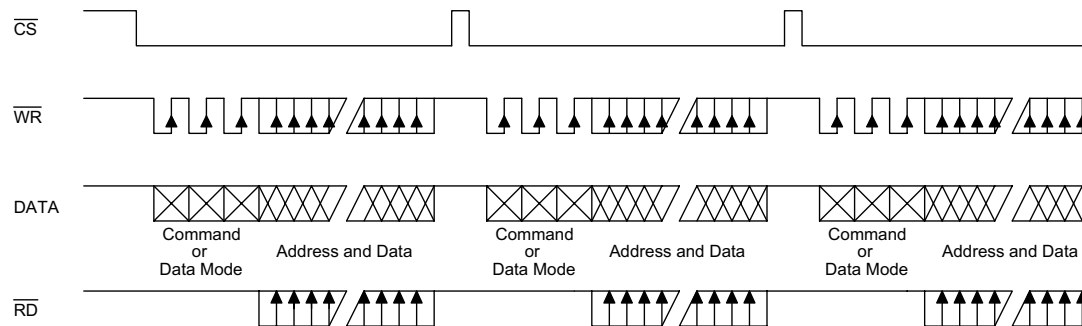

Application Circuits

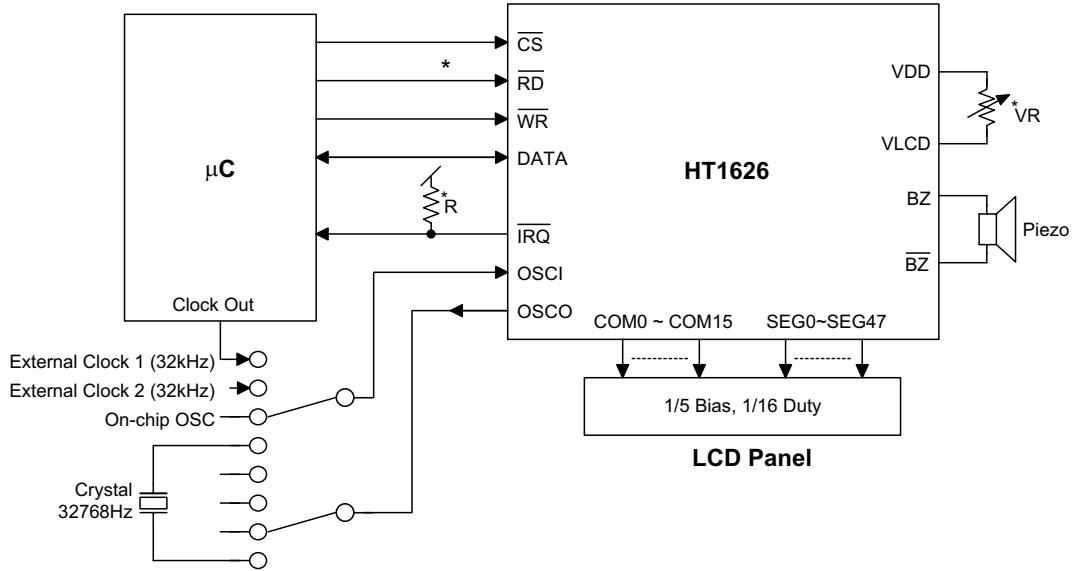

*Note: The connection of \overline{IRQ} and \overline{RD} pin can be selected depending on the requirement of the μC .
 The volatage applied to V_{LCD} pin must be lower than V_{DD} .
 Adjust VR to fit LCD display, at $V_{DD}=5V$, $V_{LCD}=4V$, $VR=15k\Omega\pm 20\%$.
 Adjust R (external pull-high resistance) to fit user's time base clock.

Instruction Set Summary

Name	ID	Command Code	D/C	Function	Def.
READ	1 1 0	A7A6A5A4A3A2A1A0D0D1D2D3	D	Read data from the RAM	
WRITE	1 0 1	A7A6A5A4A3A2A1A0D0D1D2D3	D	Write data to the RAM	
READ-MODIFY-WRITE	1 0 1	A7A6A5A4A3A2A1A0D0D1D2D3	D	Read and Write data to the RAM	
SYS DIS	1 0 0	0000-0000-X	C	Turn off both system oscillator and LCD bias generator	Yes
SYS EN	1 0 0	0000-0001-X	C	Turn on system oscillator	
LCD OFF	1 0 0	0000-0010-X	C	Turn off LCD display	Yes
LCD ON	1 0 0	0000-0011-X	C	Turn on LCD display	
TIMER DIS	1 0 0	0000-0100-X	C	Disable time base output	Yes
WDT DIS	1 0 0	0000-0101-X	C	Disable WDT time-out flag output	Yes
TIMER EN	1 0 0	0000-0110-X	C	Enable time base output	
WDT EN	1 0 0	0000-0111-X	C	Enable WDT time-out flag output	
TONE OFF	1 0 0	0000-1000-X	C	Turn off tone outputs	Yes
CLR TIMER	1 0 0	0000-1101-X	C	Clear the contents of the time base generator	
CLR WDT	1 0 0	0000-1111-X	C	Clear the contents of the WDT stage	
RC 32K	1 0 0	0001-10XX-X	C	System clock source, on-chip RC oscillator	Yes
EXT (XTAL) 32K	1 0 0	0001-11XX-X	C	System clock source, external 32kHz clock source or crystal oscillator 32.768kHz	
TONE 4K	1 0 0	010X-XXXX-X	C	Tone frequency output: 4kHz	
TONE 2K	1 0 0	0110-XXXX-X	C	Tone frequency output: 2kHz	
$\overline{\text{IRQ}}$ DIS	1 0 0	100X-0XXX-X	C	Disable $\overline{\text{IRQ}}$ output	Yes
$\overline{\text{IRQ}}$ EN	1 0 0	100X-1XXX-X	C	Enable $\overline{\text{IRQ}}$ output	
F1	1 0 0	101X-0000-X	C	Time base clock output: 1Hz The WDT time-out flag after: 4s	
F2	1 0 0	101X-0001-X	C	Time base clock output: 2Hz The WDT time-out flag after: 2s	
F4	1 0 0	101X-0010-X	C	Time base clock output: 4Hz The WDT time-out flag after: 1s	

Name	ID	Command Code	D/C	Function	Def.
F8	1 0 0	101X-0011-X	C	Time base clock output: 8Hz The WDT time-out flag after: 1/2 s	
F16	1 0 0	101X-0100-X	C	Time base clock output: 16Hz The WDT time-out flag after: 1/4 s	
F32	1 0 0	101X-0101-X	C	Time base clock output: 32Hz The WDT time-out flag after: 1/8 s	
F64	1 0 0	101X-0110-X	C	Time base clock output: 64Hz The WDT time-out flag after: 1/16 s	
F128	1 0 0	101X-0111-X	C	Time base clock output: 128Hz The WDT time-out flag after: 1/32 s	Yes
TEST	1 0 0	1110-0000-X	C	Test mode, user don't use.	
NORMAL	1 0 0	1110-0011-X	C	Normal mode	Yes

Note: X : Don't care

A7~A0 : RAM address

D3~D0 : RAM data

D/C : Data/Command mode

Def. : Power on reset default

All the bold forms, namely **1 1 0**, **1 0 1**, and **1 0 0**, are mode commands. Of these, **1 0 0** indicates the command mode ID. If successive commands have been issued, the command mode ID except for the first command will be omitted. The source of the tone frequency and of the time base/WDT clock frequency can be derived from an on-chip 32kHz RC oscillator, a 32.768kHz crystal oscillator, or an external 32kHz clock. Calculation of the frequency is based on the system frequency sources as stated above. It is recommended that the host controller should initialize the HT1626 after power on reset, for power on reset may fail, which in turn leads to the malfunctioning of the HT1626.

Holtek Semiconductor Inc. (Headquarters)

No.3 Creation Rd. II, Science-based Industrial Park, Hsinchu, Taiwan, R.O.C.
Tel: 886-3-563-1999
Fax: 886-3-563-1189

Holtek Semiconductor Inc. (Taipei Office)

5F, No.576, Sec.7 Chung Hsiao E. Rd., Taipei, Taiwan, R.O.C.
Tel: 886-2-2782-9635
Fax: 886-2-2782-9636
Fax: 886-2-2782-7128 (International sales hotline)

Holtek Semiconductor (Hong Kong) Ltd.

RM.711, Tower 2, Cheung Sha Wan Plaza, 833 Cheung Sha Wan Rd., Kowloon, Hong Kong
Tel: 852-2-745-8288
Fax: 852-2-742-8657

Copyright © 2000 by HOLTEK SEMICONDUCTOR INC.

The information appearing in this Data Sheet is believed to be accurate at the time of publication. However, Holtek assumes no responsibility arising from the use of the specifications described. The applications mentioned herein are used solely for the purpose of illustration and Holtek makes no warranty or representation that such applications will be suitable without further modification, nor recommends the use of its products for application that may present a risk to human life due to malfunction or otherwise. Holtek reserves the right to alter its products without prior notification. For the most up-to-date information, please visit our web site at <http://www.holtek.com.tw>.