



HT16515

1/4 to 1/12 Duty VFD Controller

Features

- Logic voltage: 5V
- High-voltage output: V_{DD} -35V max.
- Multiple display (16-segment & 12-digit to 24-segment & 4-digit)
- 16×2 matrix key scanning
- 8 steps dimmer circuit
- 4 LED output ports (20mA max.)
- No external resistors necessary for driver output (provides PMOS open-drain and pull-low resistor output)
- Serial interface with MCU (CLK, \overline{CS} , DI, DO)
- 44-pin QFP package

Applications

- Consumer products panel function control
- Industrial measuring instrument panel function control
- Other similar applications for panel function control

General Description

HT16515 is a VFD (Vacuum Fluorescent Display) controller/driver that is driven on a 1/4 to 1/12 duty factor. It consists of 16 segment output lines, 4 grid output lines, 8 segment/grid output drive lines, 4 LED output ports, a control circuit, a display memory, and a key scan circuit.

Serial data inputs to the HT16515 through a three-line serial interface. This VFD controller/driver is an ideal MCU peripheral device.

Block Diagram

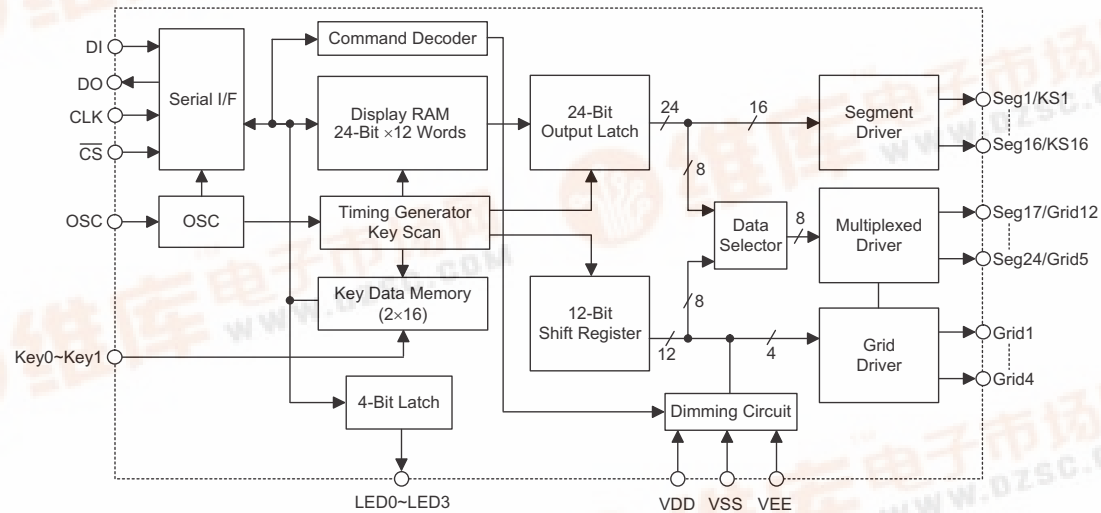

Pin Assignment

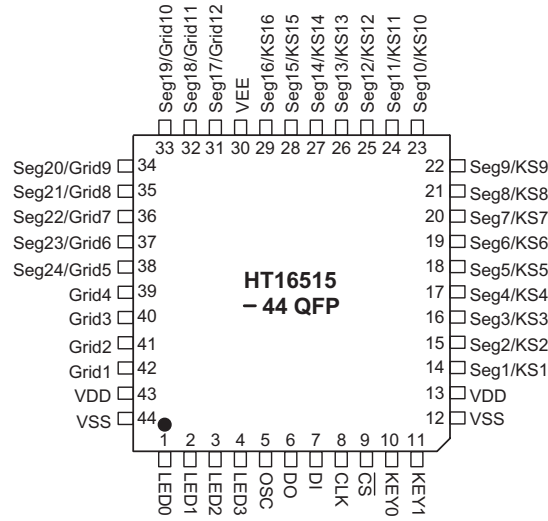

Pad Assignment

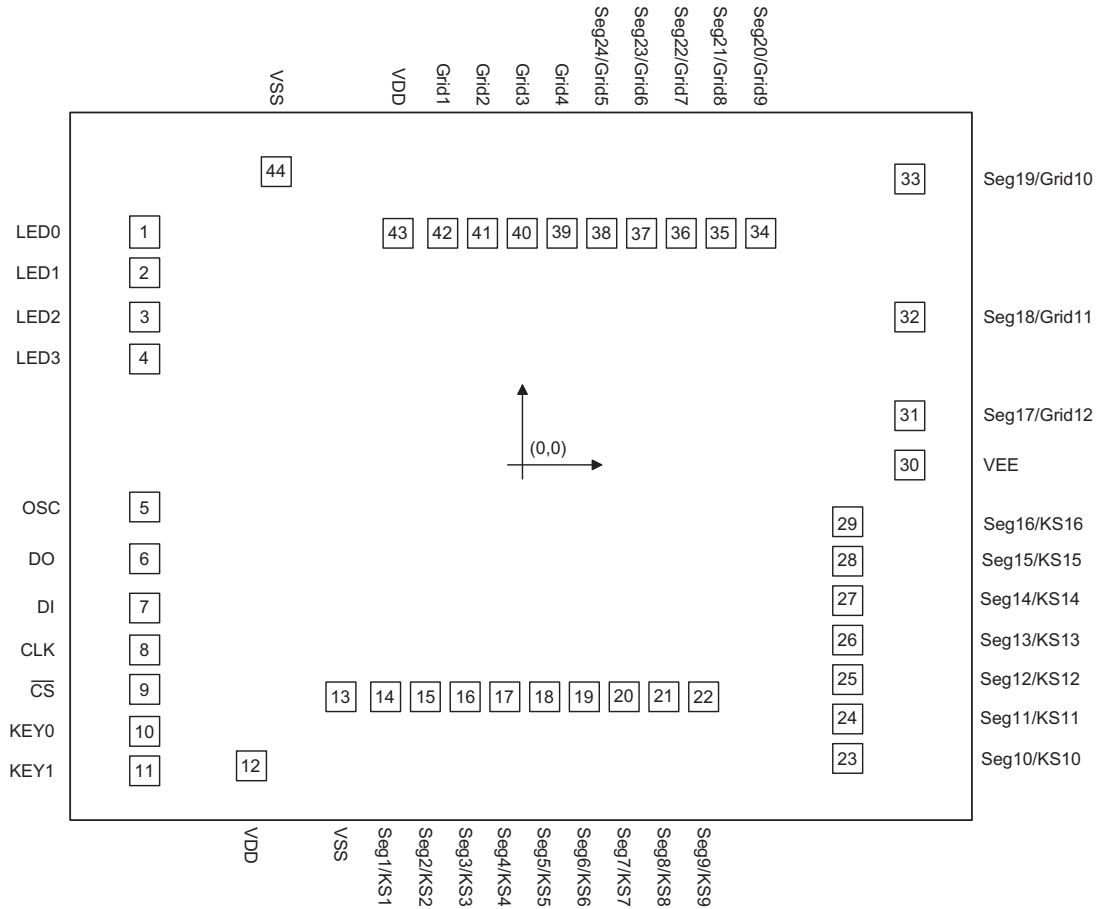

* The IC substrate should be connected to VSS in the PCB layout artwork.

Pad Coordinates

 Unit: μm

Pad No.	X	Y	Pad No.	X	Y
1	-962.50	600.00	23	834.10	-754.00
2	-962.50	495.00	24	834.10	-652.60
3	-962.50	380.20	25	834.10	-551.20
4	-962.50	275.20	26	834.10	-449.80
5	-962.50	-107.20	27	834.10	-348.40
6	-962.50	-235.60	28	834.10	-247.00
7	-962.50	-366.00	29	834.10	-145.60
8	-962.50	-471.00	30	987.30	0.50
9	-962.50	-576.00	31	987.30	130.50
10	-962.50	-681.00	32	987.30	382.05
11	-962.50	-786.00	33	987.30	734.05
12	-689.60	-772.45	34	610.30	594.40
13	-460.45	-595.30	35	508.90	594.40
14	-344.25	-595.30	36	407.50	594.40
15	-242.85	-595.30	37	306.10	594.40
16	-141.45	-595.30	38	204.70	594.40
17	-40.05	-595.30	39	103.30	594.40
18	61.35	-595.30	40	1.90	594.40
19	162.75	-595.30	41	-99.50	594.40
20	264.15	-595.30	42	-200.90	594.40
21	365.55	-595.30	43	-317.10	594.40
22	466.95	-595.30	44	-624.50	756.80

Pin Description

Pin No.	Pin Name	I/O	Description
1~4	LED3~LED0	O	LED driver output ports. This is a CMOS output pin and maximum driving current up to +20mA.
5	OSC	I	Connected to an external resistor or an RC oscillator circuit.
6	DO	O	Data output pin, output serial data at falling edge of shift clock, starting from the lower bit. This is N-ch open-drain output pin.
7	DI	I	Data input pin, input serial data at rising edge of shift clock, starting from the lower bit.
8	CLK	I	Clock input pin. Reads serial data at the rising edge, and outputs data at the falling edge.
9	$\overline{\text{CS}}$	I	Initializes serial interface at the rising or falling edge of the HT16515. Then it waits to receive a command. Data input after CS has fallen is processed, current processing is stopped, and the serial interface is initialized. While $\overline{\text{CS}}$ is high, CLK is ignored.
10, 11	Key0, Key1	I	Key-in data input to these pins are latched at the end of the display cycle.
12, 44	VSS	—	Negative power supply, ground
13, 43	VDD	—	Positive power supply
14~29	Seg1/KS1~Seg16/KS16	O	High voltage output, segment output pins, dual function as key source. This is PMOS open-drain and pull-low resistor output.
30	VEE	—	VFD power supply
31~38	Seg17/Grid12~Seg24/Grid5	O	High voltage output, these pins are selectable for segment or grid output. This is PMOS open-drain and pull-low resistor output.
39~42	Grid4~Grid1	O	High voltage output, grids output pin. This is PMOS open-drain and pull-low resistor output.

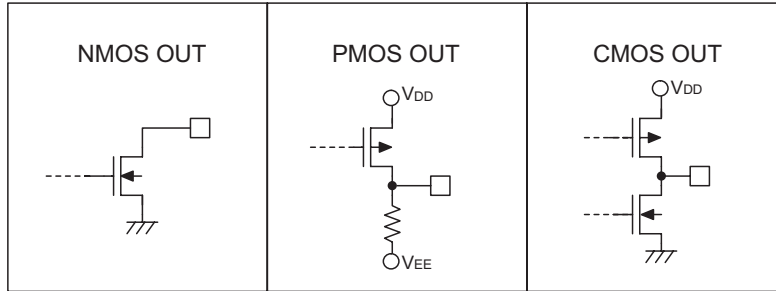
Approximate Internal Connections

Absolute Maximum Ratings

Supply Voltage	$V_{SS}-0.3V$ to $V_{SS}+6.0V$	Operating Temperature.....	$-25^{\circ}C$ to $75^{\circ}C$
Input Voltage.....	$V_{SS}-0.3V$ to $V_{DD}+0.3V$	Storage Temperature	$-50^{\circ}C$ to $125^{\circ}C$

Note: These are stress ratings only. Stresses exceeding the range specified under "Absolute Maximum Ratings" may cause substantial damage to the device. Functional operation of this device at other conditions beyond those listed in the specification is not implied and prolonged exposure to extreme conditions may affect device reliability.

D.C. Characteristics
 $T_a=25^{\circ}C$

Symbol	Parameter	Test Conditions		Min.	Typ.	Max.	Unit
		V_{DD}	Conditions				
V_{DD}	Logic Supply Voltage	—	—	4.5	5	5.5	V
V_{EE}	VFD Supply Voltage	—	—	0	—	$V_{DD}-35$	V
f_{OSC}	Oscillation Frequency	5V	$R_{OSC}=82k\Omega$	350	500	650	kHz
R_{PL}	Output Pull-low Resistor	5V	Driver output	40	65	120	$k\Omega$
I_{DD}	Operating Current	5V	No load, VFD display off	—	—	5	mA
I_{OL}	Driver Leakage Current	5V	$V_O=V_{DD}-30V$, VFD driver off	—	—	-10	μA
I_{OL1}	LED Sink Current	5V	$V_{OL}=1V$, LED0~LED3	20	—	—	mA
I_{OH1}	LED Source Current	5V	$V_{OH}=0.9V_{DD}$, LED0~LED3	-3	—	—	mA
I_{OH21}	Segment 1~16 Source Current	5V	$V_{OH}=V_{DD}-2V$	-3	—	—	mA
I_{OH22}	Segment 17~24, Grid 1~4 Source Current	5V	$V_{OH}=V_{DD}-2V$	-15	—	—	mA
I_{OL3}	DO Sink Current	5V	$V_{OL}=0.4V$	4	—	—	mA
V_{IH}	"H" Input Voltage	—	—	$0.7V_{DD}$	—	V_{DD}	V
V_{IL}	"L" Input Voltage	—	—	0	—	$0.3V_{DD}$	V
V_H	Hysteresis Voltage	—	CLK, D_{IN} , \overline{CS}	—	0.35	—	V
V_{OH1}	High-level Output Voltage	5V	LED0~LED3, $I_{OH1}=-3mA$	$0.9V_{DD}$	—	V_{DD}	V
V_{OL1}	Low-level Output Voltage	5V	LED0~LED3, $I_{OL1}=20mA$	0	—	1	V
V_{OL2}	Low-level Output Voltage	5V	DO, $I_{OL2}=4mA$	0	—	0.4	V

A.C. Characteristics

Ta=25°C

Symbol	Parameter	Test Conditions		Min.	Typ.	Max.	Unit
		V _{DD}	Conditions				
t _{PHL}	Logic Supply Voltage	5V	CLK→DO	—	—	300	ns
t _{PLH}		5V	C _L =15pF, R _L =10kΩ	—	—	300	ns
t _{r1}	Rise Time	5V	C _L =300pF, S1~S16	—	—	2	μs
t _{r2}		5V	C _L =300pF, G1~G4 S17/G12~S24/G5	—	—	0.5	μs
t _f	Fall Time	5V	C _L =300pF, Sn, Gn	—	—	120	μs
t _{max}	Maximum Clock Frequency	5V	Duty=50%	1	—	—	MHz
C _i	Input Capacitance	5V	—	—	—	15	pF
t _{CW}	Clock Pulse Width	5V	—	400	—	—	ns
t _{SW}	Strobe Pulse Width	5V	—	1	—	—	us
t _{SU}	Data Setup Time	5V	—	100	—	—	ns
t _h	Data Hold Time	5V	—	100	—	—	ns
t _{CS}	Clock-Strobe Time	5V	CLK rising edge to $\overline{\text{CS}}$ rising edge	1	—	—	μs
t _W	Wait Time	5V	CLK rising edge to CLK falling edge	1	—	—	μs

Functional Description
Display RAM and Display Mode

The static display RAM stores the data transmitted from an external device to the HT16515 through a serial interface. The contents of the RAM are directly mapped to the contents of the VFD driver. Data in the RAM can be accessed through the data setting, address setting and display control commands. It is assigned as addresses in 8-bit unit as follows:

SEG1	SEG4	SEG8	SEG12	SEG16	SEG20	SEG24	
00HL	00Hu	01HL	01Hu	02HL	02Hu		DIG1
03HL	03Hu	04HL	04Hu	05HL	05Hu		DIG2
06HL	06Hu	07HL	07Hu	08HL	08Hu		DIG3
09HL	09Hu	0AHL	0AHu	0BHL	0BH <u>u</u>		DIG4
0CHL	0CHu	0DHL	0DHu	0EHL	0EHu		DIG5
0FHL	0FHu	10HL	10Hu	11HL	11Hu		DIG6
12HL	12Hu	13HL	13Hu	14HL	14Hu		DIG7
15HL	15Hu	16HL	16Hu	17HL	17Hu		DIG8
18HL	18Hu	19HL	19Hu	1AHL	1AHu		DIG9
1BHL	1BH <u>u</u>	1CHL	1CHu	1DHL	1DHu		DIG10
1EHL	1EHu	1FHL	1FHu	20HL	20Hu		DIG11
21HL	21Hu	22HL	22Hu	23HL	23Hu		DIG12

b0 b3b4 b7

XXHL	XXHu
------	------

 Lower Higher
 4 bits 4 bits

Dimming Control

HT16515 provides an 8-step dimmer function on display by controlling the 3-bit binary command code. The full pulse width of grid signal is divided into 16 uniform sections by PWM (pulse width modulation) technology.

The 16 uniform sections available form an 8-step dimmer via 3-bit binary code. The 8-step dimmer includes 1/16, 2/16, 4/16, 10/16, 11/16, 12/16, 13/16 and 14/16. The 1/16 pulse width indicates minimum lightness. The 14/16 pulse width represents maximum lightness (Refer to the display control command).

Key Matrix and Key-Input Data Storage RAM

The key matrix scans the series key states at each level of the key strobe signal (Seg1/K1~Seg16/K16) output of the HT16515. The key strobe signal outputs are time-multiplexed signals from Seg1/K1~Seg16/K16. The states of inputs K0 and K1 are sampled by strobe signal Seg1/K1~Seg16/K16 and latched into the register.

The key matrix is made up of a 16x2 matrix, as shown below.

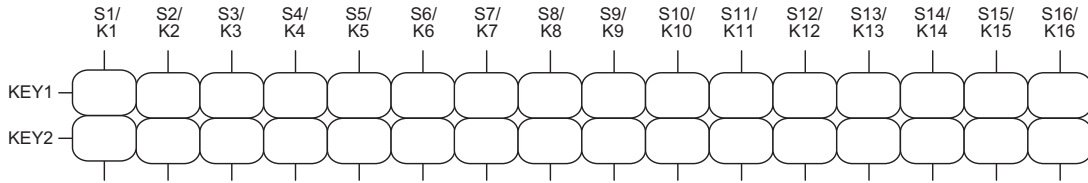

The data of each key is stored as illustrated below, and is read with the read command, starting from the least significant bit.

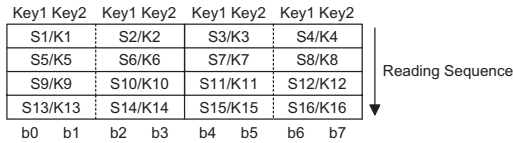

LED Port

The LED port is of the CMOS output configuration.

Data is written to the LED port with the write command, starting from the least significant bit. In our application (see application circuits), the user adopts an internal NMOS device to a driver LED component by connecting VDD. When a bit of this port is 0, the corresponding LED lights up; when the bit is 1, the LED turns off. The data of bits 4 through 7 are ignored.

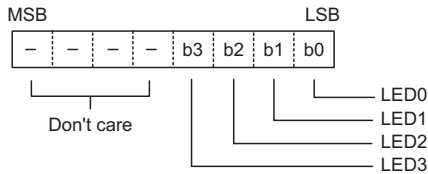

Commands

Commands set the display mode and status of the VFD driver.

The first 1 byte input to the HT16515 through the DI pin after the CS pin has fallen, is regarded as a command. If CS is set high while commands/data are transmitted, serial communication is initialized, and the commands/data being transmitted are not valid (however, the commands/data previously transmitted remains valid).

• Display mode setting commands

These commands initialize the HT16515 and select the number of segments and the number of grids (1/4~1/12 duty, 16 to 24 segments).

When these commands are executed, the display is forcibly turned off, and key scanning is also stopped.

To resume display, the display command "ON" must be executed. If the same mode is selected, nothing happens.

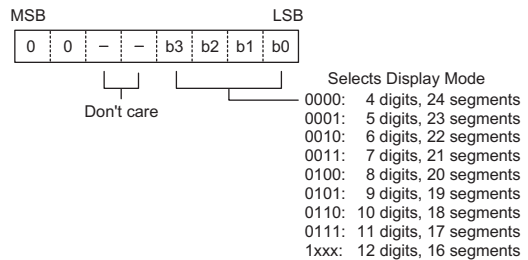

Note: Power-on status: 12-digit, 16 segment mode is selected.

Timing Diagrams

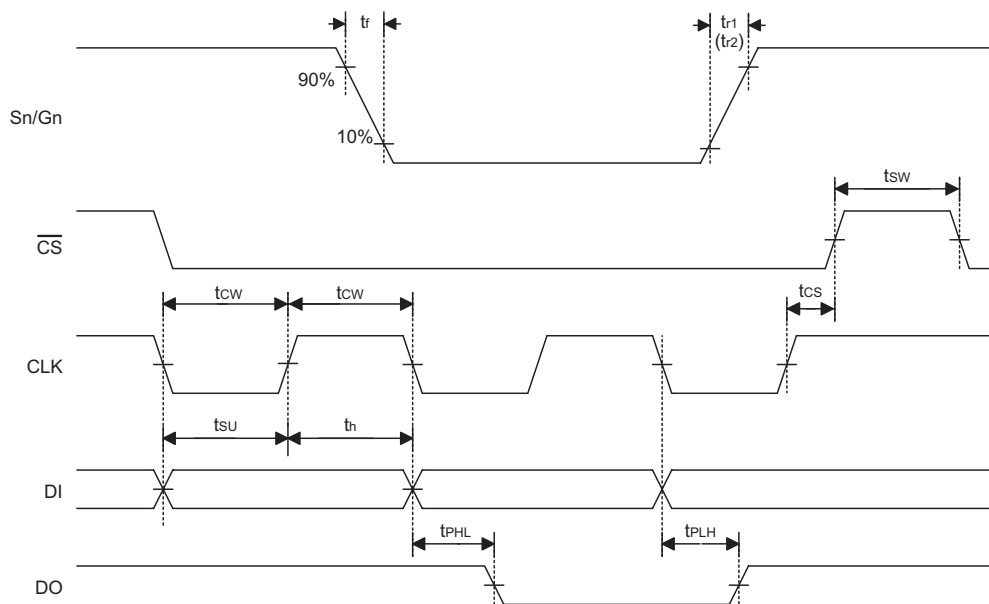

Key Scanning and Display Timing

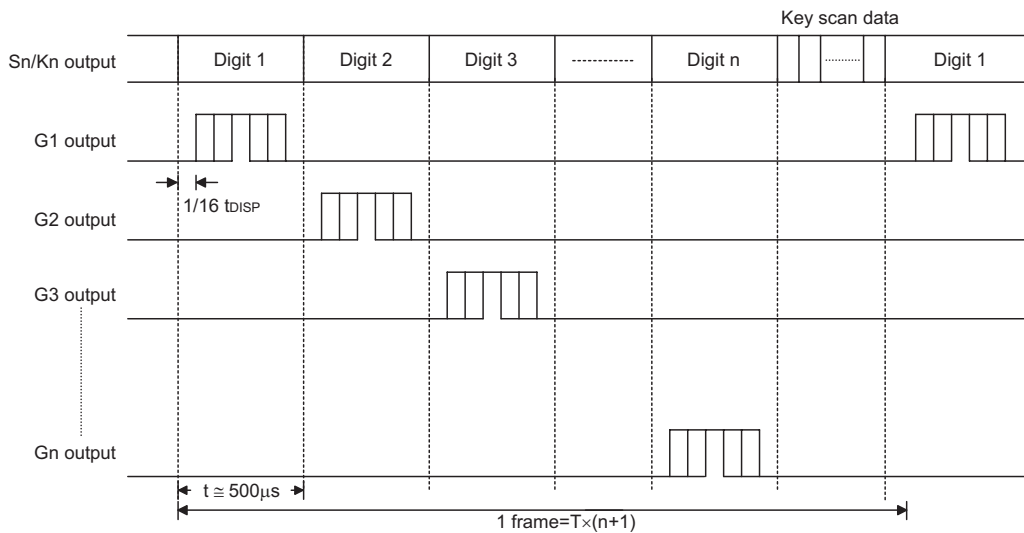

Note: One cycle of key scanning consists of two frames, and data of 16×2 matrixes is stored in the RAM.

Serial Communication Format

- Reception (command/data write)

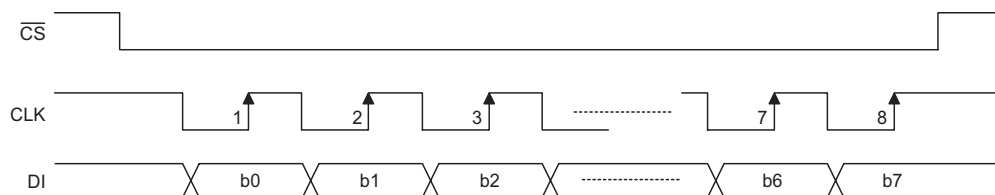

- Transmission (data read)

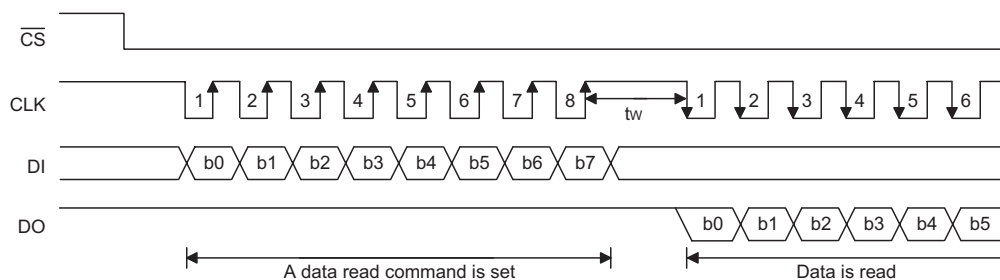

Be sure to connect an external pull-high resistor to this pin (1k Ω to 10k Ω).

Note: When data is read, a wait time "t_w" of 1 μ s is necessary.

- Updating display memory by incrementing address

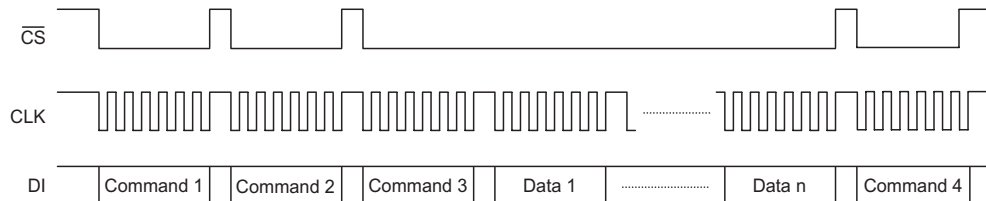

Note: Command 1: sets display mode

Command 2: sets data

Command 3: sets address

Data 1 to n: transfers display data (36 bytes max.)

Command 4: controls display

- Updating specific addresses

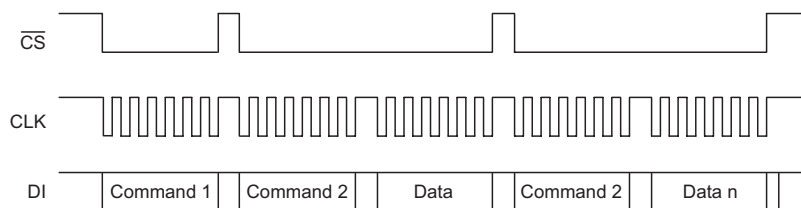

Note: Command 1: sets data

Command 2: sets address

Data: display data

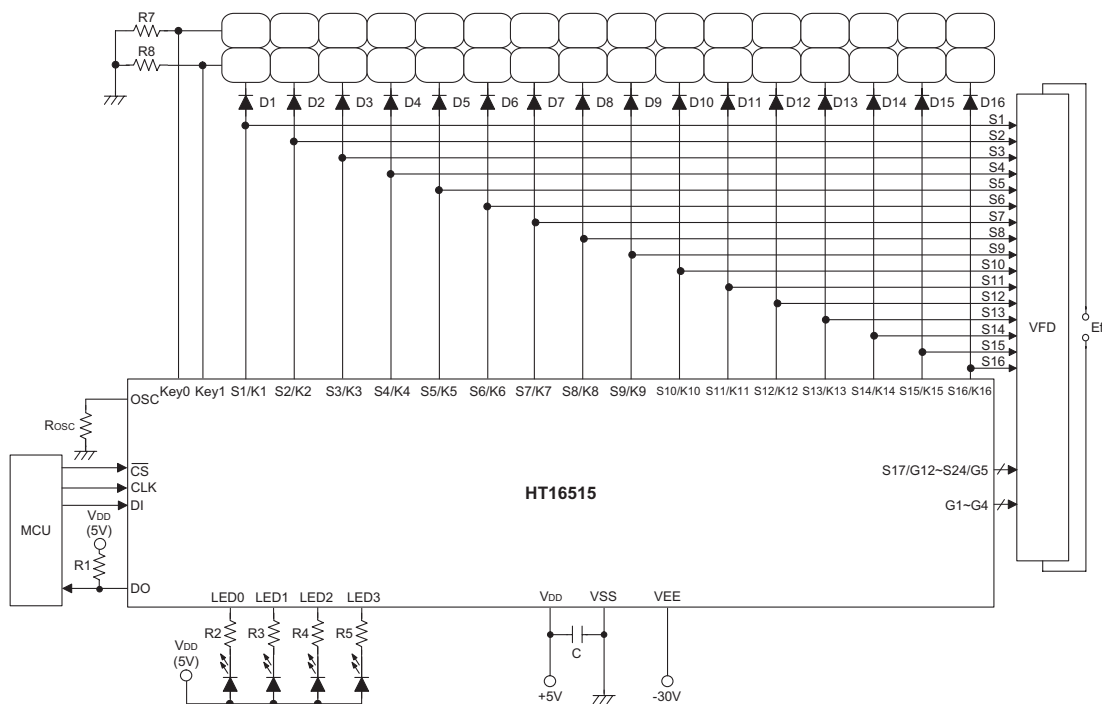
Application Circuits

- Note:
- $R_{OSC}=82k\Omega$ for oscillator resistor
 - $R1=1\sim 10k\Omega$ for external pull-high resistor
 - $R2\sim R6=750\Omega\sim 1.2k\Omega$
 - $R7\sim R8=10k\Omega$ for external pull-low resistor
 - $D1\sim D6=1N4001$
 - E_f =Filament voltage for VFD
 - $C=0.1\mu F\sim 1.0\mu F$

Package Information

44-pin QFP (10×10) Outline Dimensions

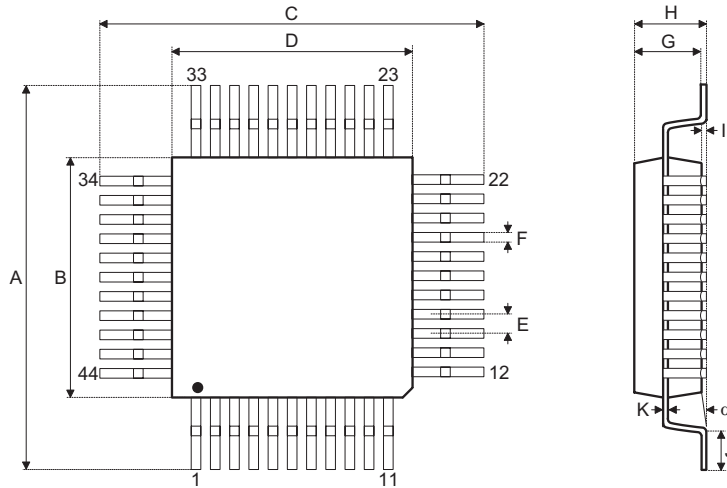

Symbol	Dimensions in mm		
	Min.	Nom.	Max.
A	13	—	13.40
B	9.90	—	10.10
C	13	—	13.40
D	9.90	—	10.10
E	—	0.80	—
F	—	0.30	—
G	1.90	—	2.20
H	—	—	2.70
I	—	0.10	—
J	0.73	—	0.93
K	0.10	—	0.20
α	0°	—	7°

Holtek Semiconductor Inc. (Headquarters)

No.3, Creation Rd. II, Science Park, Hsinchu, Taiwan
Tel: 886-3-563-1999
Fax: 886-3-563-1189
<http://www.holtek.com.tw>

Holtek Semiconductor Inc. (Taipei Sales Office)

4F-2, No. 3-2, YuanQu St., Nankang Software Park, Taipei 115, Taiwan
Tel: 886-2-2655-7070
Fax: 886-2-2655-7373
Fax: 886-2-2655-7383 (International sales hotline)

Holtek Semiconductor Inc. (Shanghai Sales Office)

7th Floor, Building 2, No.889, Yi Shan Rd., Shanghai, China 200233
Tel: 021-6485-5560
Fax: 021-6485-0313
<http://www.holtek.com.cn>

Holtek Semiconductor Inc. (Shenzhen Sales Office)

43F, SEG Plaza, Shen Nan Zhong Road, Shenzhen, China 518031
Tel: 0755-8346-5589
Fax: 0755-8346-5590
ISDN: 0755-8346-5591

Holtek Semiconductor Inc. (Beijing Sales Office)

Suite 1721, Jinyu Tower, A129 West Xuan Wu Men Street, Xicheng District, Beijing, China 100031
Tel: 010-6641-0030, 6641-7751, 6641-7752
Fax: 010-6641-0125

Holmate Semiconductor, Inc. (North America Sales Office)

46712 Fremont Blvd., Fremont, CA 94538
Tel: 510-252-9880
Fax: 510-252-9885
<http://www.holmate.com>

Copyright © 2003 by HOLTEK SEMICONDUCTOR INC.

The information appearing in this Data Sheet is believed to be accurate at the time of publication. However, Holtek assumes no responsibility arising from the use of the specifications described. The applications mentioned herein are used solely for the purpose of illustration and Holtek makes no warranty or representation that such applications will be suitable without further modification, nor recommends the use of its products for application that may present a risk to human life due to malfunction or otherwise. Holtek's products are not authorized for use as critical components in life support devices or systems. Holtek reserves the right to alter its products without prior notification. For the most up-to-date information, please visit our web site at <http://www.holtek.com.tw>.