

Features

- Single-chip CMOS construction
- Single 1.5V battery operation
- Measurement range: +32.0~+42.0°C (+90.0~+108.0°F)
Measurement accuracy: $\pm 0.1^{\circ}\text{C}$ ($\pm 0.2^{\circ}\text{F}$)
Resolution: 0.1°C (0.1°F)
- Bonding option for Centigrade/Fahrenheit measurement
- Alarm warning for fever
- Highest temperature hold
- Auto power off after 8 min 40 sec
- One-key input switch for ON/OFF
- Displays last time measured temperature

General Description

The HT7500 is a CMOS digital clinical thermometer IC for measuring body temperature in Centigrade ($^{\circ}\text{C}$) or Fahrenheit ($^{\circ}\text{F}$) mode by its bonding option. It also provides alarm and auto

power off functions. The other electronic components are LCD display, thermister, 1.5V battery, ON/OFF switch, buzzer, resistors and capacitors.

Block Diagram

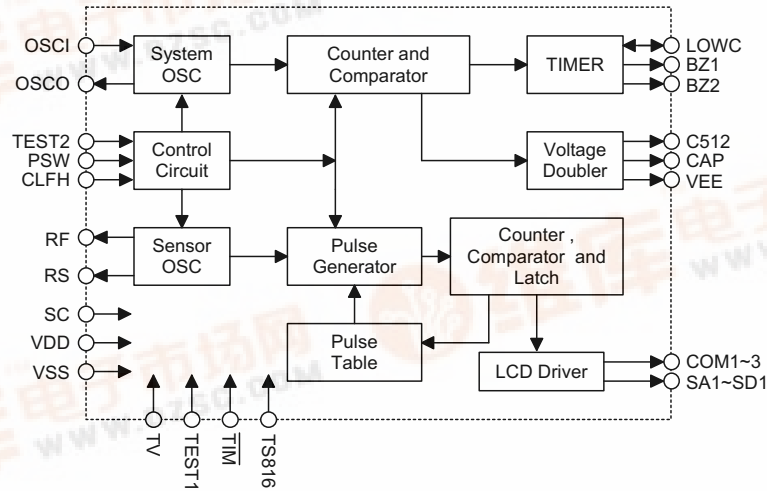

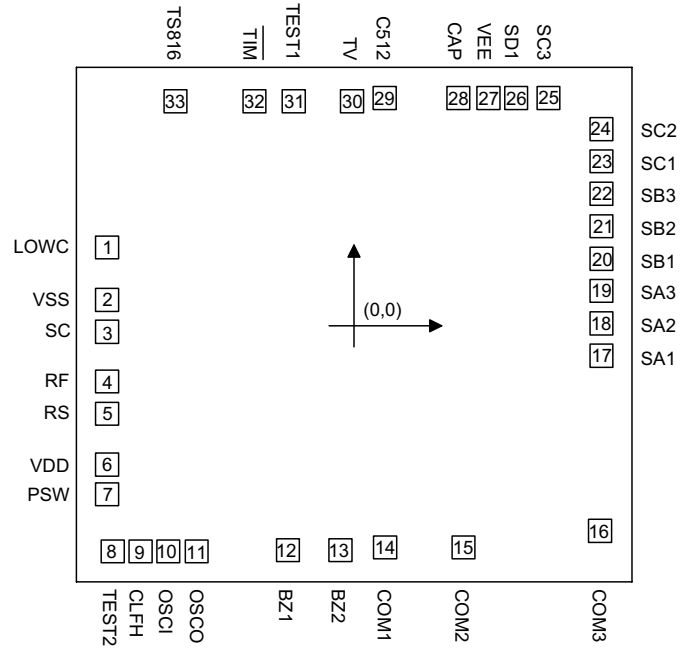
Pad Assignment

Chip size: 129 × 120 (mil)²

* The IC substrate should be connected to VDD in the PCB layout artwork.

Pad Coordinates

Unit: mil

Pin No.	X	Y	Pin No.	X	Y
1	-58.61	18.57	18	58.82	0.51
2	-58.61	6.16	19	58.82	8.24
3	-58.61	-1.49	20	58.82	15.90
4	-58.61	-13.30	21	58.82	23.63
5	-58.61	-20.95	22	58.82	31.28
6	-58.61	-33.02	23	58.82	39.01
7	-58.61	-40.08	24	58.82	46.67
8	-57.25	-53.63	25	46.24	54.06
9	-50.62	-53.63	26	38.59	54.06
10	-43.99	-53.63	27	31.96	54.06
11	-37.36	-53.63	28	24.82	54.06
12	-15.64	-53.34	29	7.39	54.06
13	-3.19	-53.34	30	-0.43	53.29
14	7.44	-52.66	31	-14.28	53.29
15	26.05	-52.66	32	-23.63	53.29
16	58.48	-48.75	33	-42.33	53.29
17	58.82	-7.14			

Pad Description

Pad No.	Pad Name	I/O	Function
1	LOWC	B	For the supply voltage detector, open the pin when not in use.
2	VSS	I	Power supply GND
3	SC	B	Common point, NMOS open drain
4	RF	O	Connect reference resistor, PMOS open drain
5	RS	O	Connect sensor resistor, PMOS open drain
6	VDD	—	Positive power supply
7	PSW	I	Pull-low input pin, push switch to turn power on or off
8	TEST2	I	Pull-low test pin, for production test, floating LCD displays the real time value, when connected to VDD, LCD displays the highest value.
9	CLFH	I	Floating for °C, connect to VDD for °F
10	OSCI	I	For system oscillator in
11	OSCO	O	For system oscillator out
12	BZ1	O	Buzzer output 1
13	BZ2	O	Buzzer output 2
14~16	COM1~COM3	O	LCD backplane drive, 3-level voltage out
17~19	SA1~SA3	O	LCD segment drive
20~22	SB1~SB3	O	LCD segment drive
23~25	SC1~SC3	O	LCD segment drive
26	SD1	O	LCD segment drive
27	VEE	O	Generate negative voltage (-1.5V)
28	CAP	O	For negative voltage, NMOS output
29	C512	O	For negative voltage, inverter output
30	TV	B	Test pin for IC
31	TEST1	I	Test pin for IC
32	$\overline{\text{TIM}}$	I	Test pin for IC
33	TS816	I	Test pin for IC

Absolute Maximum Ratings

Supply voltage0V to 2.0V Input voltage $V_{SS}-0.5V$ to $V_{DD}+0.5V$
 Operation Temperature $-2.0^{\circ}C$ to $+75^{\circ}C$ Storage Temperature $-55^{\circ}C$ to $+125^{\circ}C$

Note: These are stress ratings only. Stresses exceeding the range specified under "Absolute Maximum Ratings" may cause substantial damage to the device. Functional operation of this device at other conditions beyond those listed in the specification is not implied and prolonged exposure to extreme conditions may affect device reliability.

Electrical Characteristics
 $T_a=25^{\circ}C$

Symbol	Parameter	Test Conditions		Min.	Typ.	Max.	Unit
		V_{DD}	Conditions				
V_{DD}	Operating Voltage	—	—	1.3	1.5	1.65	V
I_{DD}	Operating Current	1.5V	No load	—	60	100	μA
I_{STB}	Standby Current	1.5V	—	—	—	1.0	μA
f_{OSC}	Oscillating Frequency	1.5V	$R_{OSC}=820k\Omega$	25.6	32	38.4	kHz
$R^{\circ}C$	Temperature Measurement Accuracy at Range $35^{\circ}C\sim 39^{\circ}C$	—	—	-0.1	—	0.1	$^{\circ}C$
$R^{\circ}F$	Temperature Measurement Accuracy at Range $95^{\circ}F\sim 102^{\circ}F$	—	—	-0.2	—	0.2	$^{\circ}F$

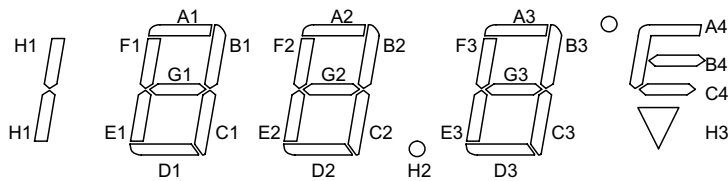
LCD Electrode Pattern

	SA1	SA2	SA3	SB1	SB2	SB3	SC1	SC2	SC3	SD1
COM1	F1	A1	B1	F2	A2	B2	F3	A3	B3	A4
COM2	E1	G1	C1	E2	G2	C2	E3	G3	C3	B4
COM3	H1	D1	—	—	D2	H2	—	D3	H3	C4

Note: 1/3 duty, 1/2 bias (LCD uses 3V)

Function Description

- Power sw: push switch to power on or power off.
- When power on: push the switch, then it will generate a "beep" sound for 0.125 sec.
 - a. First displays all the segments on for 2 sec.
 - b. After a. as described above, then shows the last time measured temperature for 2 sec.
 - c. After b., shows L °C or °F for 0.75 sec.
 - d. After c., displays the measured temperature, then °C or °F mark will flash at a speed of 1Hz.
 - e. If the temperature is < 32°C (or 90°F), the display shows L °C (or °F).
 - f. If the temperature ≥ 42°C (or 108°F) the display shows H °C (or °F).
 - g. The display always shows the higher temperature during the temperature measurement.
 - h. If the measured temperature does not change for more than 16 sec., the measurement is over and the °C (or °F) mark flash stops.
 - i. When measurement is over, if the temperature > 37.5°C (or 99.5°F) the buzzer alarms "beep-beep-beep-beep-beep-beep-" for 4 sec, as follows:
- j. It will automatically turn the power off when measurement is over for 8 min 40 sec.
- k. When measurement is over, but if the temperature rises within 8 min 40 sec, the °C (or °F) mark will flash again (repeat from step 2-d), and starts to count 8 min 40 sec again.
- l. When beep sound is on for 4 sec, the temperature is not measured.

BI BI BI
 0.125S 0.125S 0.125S 0.125S 0.125S 0.125S 0.375S

if the temperature ≤ 37.5°C (or 99.5°F), the buzzer alarms "beep-beep-beep-beep-" for 4 sec, as follows:

BI
 0.5S 0.5S

- When power off: the standby current ≤ 1μA.
- The frequency of the buzzer is 5.3kHz
- Bonding option °C or °F
- Measurement to 0.1 degree in either °C or °F
- Sensor use 503ET
- Reference resistor is the value (sensor in 37.0°C)
- When battery voltage is low, the battery mark ∇ flashes at the speed of 1Hz and the measurement may not be accurate. The low voltage detect: 1.35V ± 0.05V.
- During the process of mass production, in order to adjust the reference resistance (RF), let test 2 be floating, the measured temperature will be the actual temperature of the measured environment. It can be up or down, not always the higher one.

Flow Chart

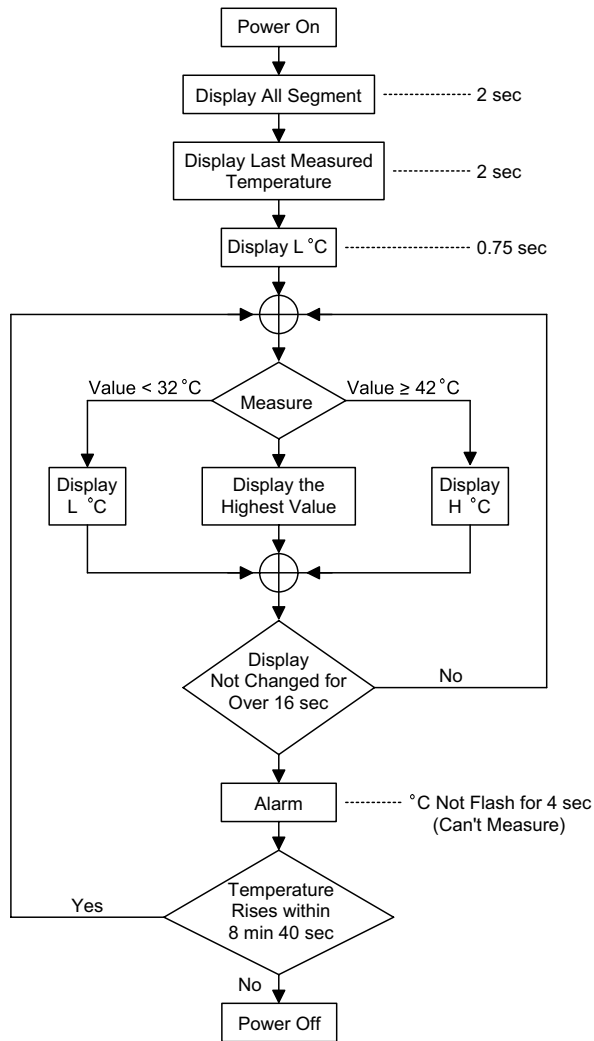

Application Circuits

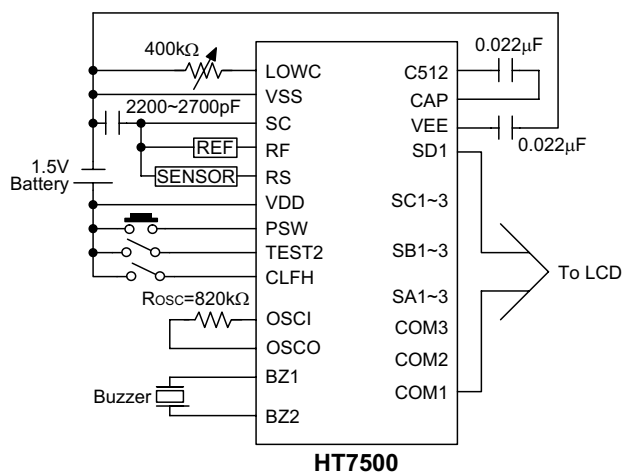

Note: Substrate connect to VDD

VEE, CAP, and C512 are externally connected to capacitors for stabilizing V_{EE} ($=-1.5V$).

BZ1 and BZ2 are connected to an external buzzer to generate sounds.

LOWC is connected to an external resistor for adjusting the detector level of a low voltage detector. Open the pin when not in use.

OSCI, OSCO are connected to an external resistor, and form an RC oscillator with a built-in capacitor for SYSTEM clock ($=32kHz$)

RS, RF, SC constitute an alternating RC oscillator, which allows one oscillator, namely RS or RF, active at a time.

REF (reference resistor) is a resistor value equal to 503ET, sensor is value in $37.0\text{ }^{\circ}C$ or $98.6\text{ }^{\circ}F$.

SENSOR is a 503ET thermistor.

Holtek Semiconductor Inc. (Headquarters)

No.3 Creation Rd. II, Science-based Industrial Park, Hsinchu, Taiwan, R.O.C.
Tel: 886-3-563-1999
Fax: 886-3-563-1189

Holtek Semiconductor Inc. (Taipei Office)

5F, No.576, Sec.7 Chung Hsiao E. Rd., Taipei, Taiwan, R.O.C.
Tel: 886-2-2782-9635
Fax: 886-2-2782-9636
Fax: 886-2-2782-7128 (International sales hotline)

Holtek Semiconductor (Hong Kong) Ltd.

RM.711, Tower 2, Cheung Sha Wan Plaza, 833 Cheung Sha Wan Rd., Kowloon, Hong Kong
Tel: 852-2-745-8288
Fax: 852-2-742-8657

Copyright © 2000 by HOLTEK SEMICONDUCTOR INC.

The information appearing in this Data Sheet is believed to be accurate at the time of publication. However, Holtek assumes no responsibility arising from the use of the specifications described. The applications mentioned herein are used solely for the purpose of illustration and Holtek makes no warranty or representation that such applications will be suitable without further modification, nor recommends the use of its products for application that may present a risk to human life due to malfunction or otherwise. Holtek reserves the right to alter its products without prior notification. For the most up-to-date information, please visit our web site at <http://www.holtek.com.tw>.