

HOLTEK



HTG2150

Preliminary 8-Bit 320 Pixel LCD Microcontroller

Features

- Operating voltage: 2.2V~3.6V
- 16K × 16 bits program ROM
- 192 × 8 bits data RAM
- 8~12 bidirectional I/O lines
- 8 common × 33~40 segment LCD driver
- One 16-bit programmable timer with overflow interrupts
- One 8-bit programmable timer with 8 stage prescaler for PFD
- One 8-bit programmable timer with 8 stage prescaler for Time base
- One 8-bit PWM audio output to directly drive speaker and buzzer
- Watchdog Timer
- On-chip RC oscillator for system clock and 32768Hz crystal oscillator for timebase and LCD driver
- HALT function and wake-up feature reduce power consumption
- 8-level subroutine nesting
- Bit manipulation instructions
- 63 powerful instructions
- One interrupt input

General Description

The HTG2150 is an 8-bit high performance RISC-like microcontroller. The single cycle instruction and two-stage pipeline architecture make it suitable for high speed application. The device is ideally suited for multiple LCD low

power application among which are calculators, clock timer, game, scales, toys and hand held LCD products, as well as for battery systems.



Block Diagram

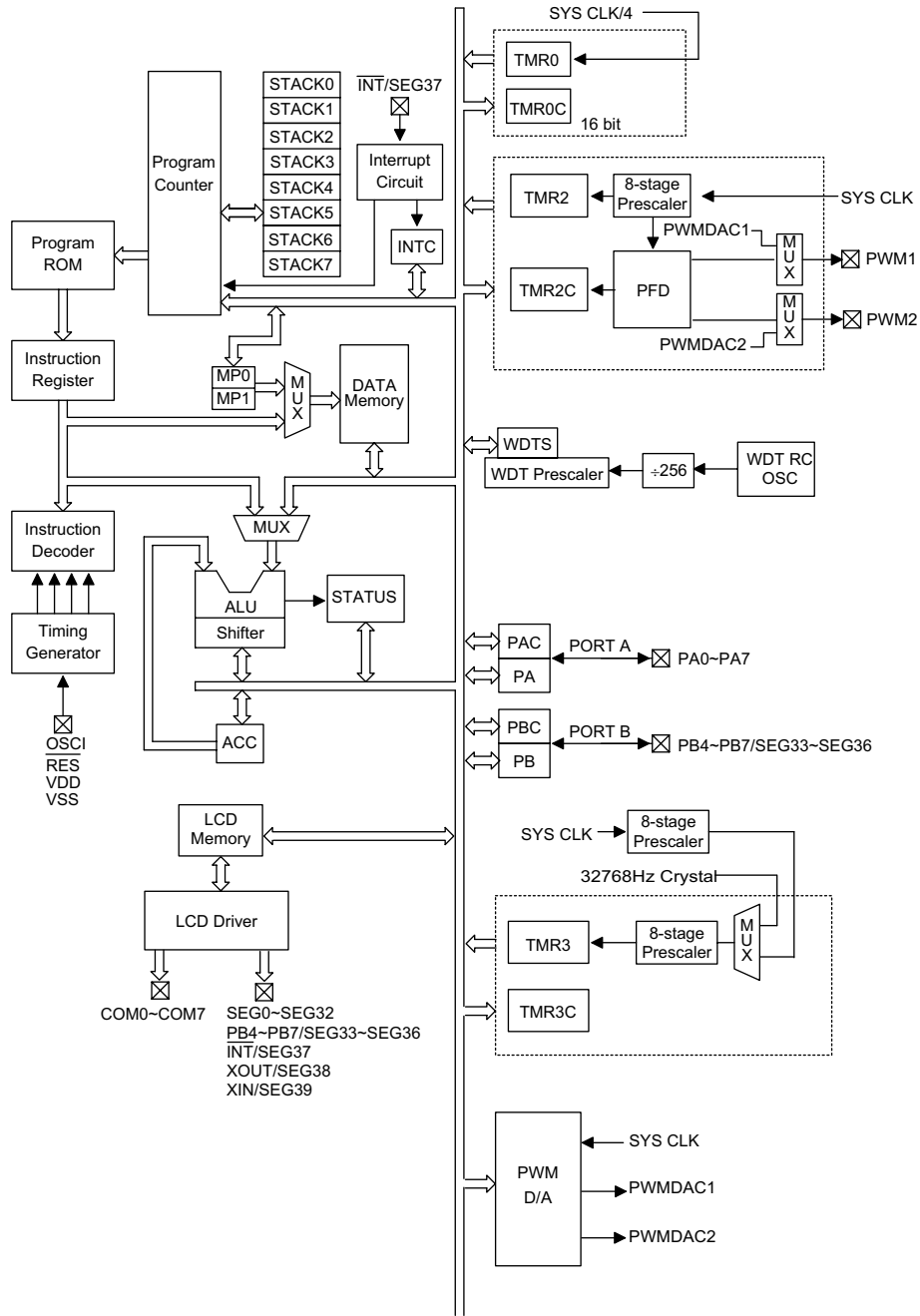

Pad Assignment

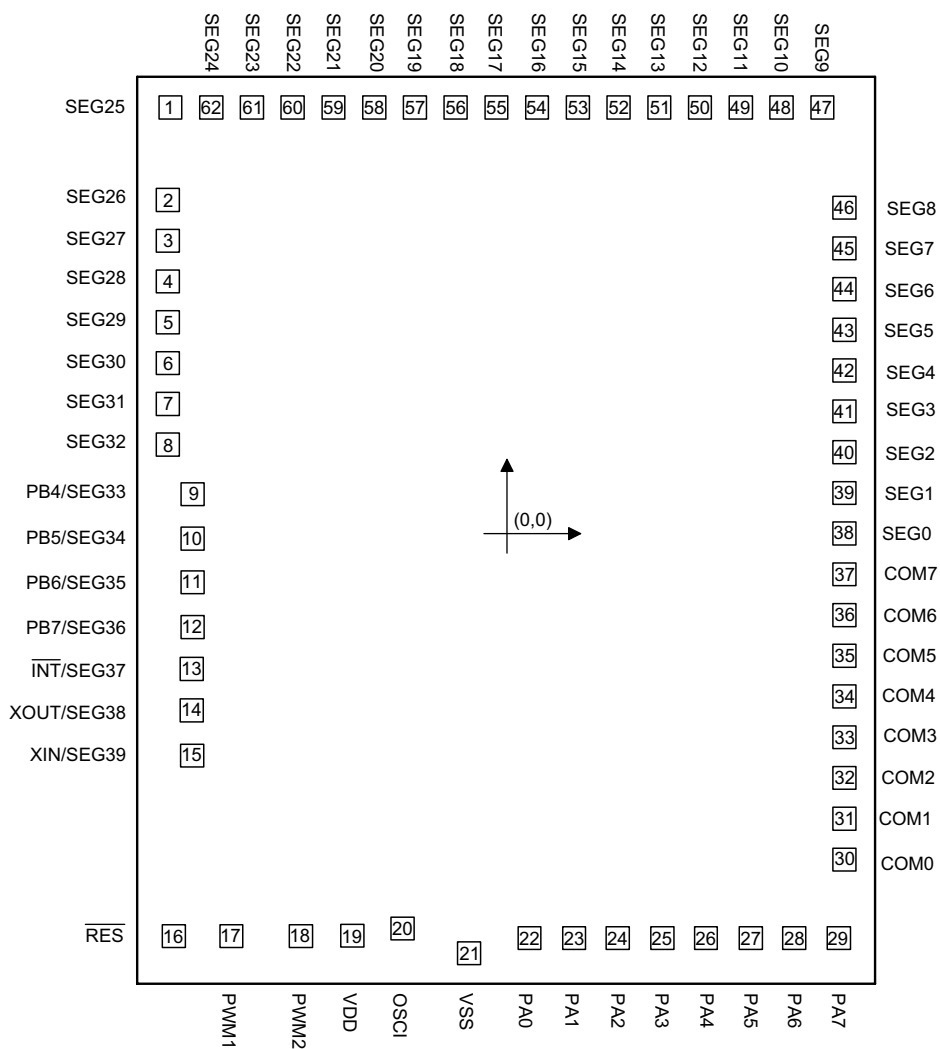

* The IC substrate should be connected to VSS in the PCB layout artwork.

Pad Coordinates

 Unit: μm

Pad No.	X	Y	Pad No.	X	Y
1	-880.45	1114.46	32	882.36	-639.47
2	-887.11	872.13	33	882.36	-532.87
3	-887.11	765.63	34	882.36	-426.37
4	-887.11	659.03	35	882.36	-319.77
5	-887.11	552.53	36	882.36	-213.27
6	-887.11	445.93	37	882.36	-106.67
7	-887.11	339.43	38	882.36	-0.17
8	-887.11	232.83	39	882.36	106.43
9	-822.70	103.48	40	882.36	212.93
10	-822.70	-13.52	41	882.36	319.53
11	-822.70	-127.52	42	882.36	426.03
12	-822.70	-244.52	43	882.36	532.63
13	-824.04	-354.49	44	882.36	639.13
14	-824.04	-462.62	45	882.36	745.73
15	-823.97	-580.52	46	882.36	852.23
16	-871.13	-1052.80	47	824.35	1114.46
17	-720.90	-1052.80	48	717.85	1114.46
18	-539.25	-1052.80	49	611.25	1114.46
19	-404.50	-1051.65	50	504.75	1114.46
20	-273.79	-1032.67	51	398.15	1114.46
21	-99.06	-1097.34	52	291.65	1114.46
22	58.61	-1057.70	53	185.05	1114.46
23	175.41	-1057.70	54	78.55	1114.46
24	289.41	-1057.70	55	-28.05	1114.46
25	406.21	-1057.70	56	-134.55	1114.46
26	520.21	-1057.70	57	-241.15	1114.46
27	637.01	-1057.70	58	-347.65	1114.46
28	751.01	-1057.70	59	-454.25	1114.46
29	867.81	-1057.70	60	-560.75	1114.46
30	882.36	-852.57	61	-667.35	1114.46
31	882.36	-745.97	62	-773.85	1114.46

Pad Description

Pad No.	Pad Name	I/O	Mask Option	Description
38~62 1~8	SEG0~SEG24 SEG25~SEG32	O	—	LCD segment signal output.
9~12	PB4~PB7/ SEG33~SEG36	I/O or O	Input/Output or Segment Output	Selectable as bidirectional input/output or LCD segment signal output by mask option. On bidirectional input/output port. Software instructions determine the CMOS output or schmitt trigger input with pull-high resistor. PB4~PB7 share pad with SEG33~SEG36.

Pad No.	Pad Name	I/O	Mask Option	Description
13	$\overline{\text{INT}}/\text{SEG37}$	I or O	Interrupt input or Segment 37 output	Selectable as external interrupt schmitt trigger input or LCD segment 37 signal output by mask option. External interrupt schmitt trigger input with pull-high resistor. Edge triggered activated on a high to low transition. $\overline{\text{INT}}$ shares pad with SEG37.
15 14	XIN/SEG39 XOUT/SEG38	I or O O	Crystal or Segment Output	Selectable as 32768Hz crystal oscillator or LCD segment signal output by mask option. Crystal oscillator (32.768kHz) for Timer 3 and LCD clock. XIN shares pad with SEG39; XOUT shares pad with SEG38.
16	$\overline{\text{RES}}$	I	—	Schmitt trigger reset input. Active low without pull-high resistor.
17	PWM1	O	CMOS	Positive PWM CMOS output
18	PWM2	O	CMOS	Negative PWM CMOS output
19	VDD	—	—	Positive power supply
20	OSCI	I	—	OSCI is connected to the RC network of the internal system clock.
21	VSS	—	—	Negative power supply, ground
22~29	PA0~PA7	I/O	Wake-up or None Wake-up	Bidirectional 8-bit input/output port. Each bit can be configured as a wake-up input by mask option. Software instructions determine the CMOS output or schmitt trigger input with pull-high resistor.
37~31	COM7~COM0	O	—	LCD common signal output

Absolute Maximum Ratings

Supply Voltage.....-0.3V to 3.6V Storage Temperature.....-50°C to 125°C
 Input Voltage..... $V_{SS}-0.3V$ to $V_{DD}+0.3V$ Operating Temperature0°C to 70°C

Note: These are stress ratings only. Stresses exceeding the range specified under "Absolute Maximum Ratings" may cause substantial damage to the device. Functional operation of this device at other conditions beyond those listed in the specification is not implied and prolonged exposure to extreme conditions may affect device reliability.

D.C. Characteristics

Ta=25°C

Symbol	Parameter	Test Conditions		Min.	Typ.	Max.	Unit
		V _{DD}	Conditions				
V _{DD}	Operating Voltage	—	—	2.2	—	3.6	V
I _{DD}	Operating Current (RC OSC)	3V	No load, f _{sys} =4MHz	—	1	2	mA
I _{STB1}	Standby Current With 7μA LCD Bias Option (RTC ON, LCD ON)	3V	No load, HALT mode	—	—	20	μA
I _{STB2}	Standby Current LCD Bias Off Option (RTC ON, LCD OFF)	3V	No load, HALT mode	—	—	5	μA
V _{IL1}	Input Low Voltage for PA/PB	3V	—	0	—	0.9	V
V _{IH1}	Input High Voltage for PA/PB	3V	—	2.1	—	3	V
V _{IL2}	Input Low Voltage ($\overline{\text{INT}}$)	3V	—	0	—	0.7	V
V _{IH2}	Input High Voltage ($\overline{\text{INT}}$)	3V	—	2.3	—	3	V
V _{IL3}	Input Low Voltage ($\overline{\text{RES}}$)	3V	—	—	1.5	—	V
V _{IH3}	Input High Voltage ($\overline{\text{RES}}$)	3V	—	—	2.4	—	V
I _{OH1}	Port A, Port B Source Current	3V	V _{OH} =2.7V	-1	-2	—	mA
I _{OH2}	Segment, Common Output Source Current	3V	V _{OH} =2.7V	-50	-90	—	μA
I _{OH3}	PWM1/PWM2 Source Current	3V	V _{OH} =2.7V	-8	-10	—	mA
I _{OL1}	Port A, Port B Sink Current	3V	V _{OL} =0.3V	1.5	4	—	mA
I _{OL2}	Segment, Common Output Sink Current	3V	V _{OL} =0.3V	80	130	—	μA
I _{OL3}	PWM1/PWM2 Sink Current	3V	V _{OH} =0.3V	12	16	—	mA
R _{PH}	Pull-high Resistance of PA/PB and $\overline{\text{INT}}$	3V	—	40	60	80	kΩ

A.C. Characteristics

Ta=25°C

Symbol	Parameter	Test Conditions		Min.	Typ.	Max.	Unit
		V _{DD}	Conditions				
f _{sys}	System Clock (RC OSC)	3V	—	400	—	4000	kHz
		2.4V	—	400	—	2000	
		2.2V	—	400	—	1000	
t _{RES}	External Reset Low Pulse Width	—	—	1	—	—	μs
t _{SST}	System Start-up Timer Period	—	Power-up or Wake-up from HALT	—	1024	—	t _{sys}
t _{INT}	Interrupt Pulse Width	—	—	1	—	—	μs

Note: t_{sys}=1/f_{sys}

Functional Description

Execution flow

The system clock for the HTG2150 is derived from an RC oscillator. The system clock is internally divided into four non-overlapping clocks. One instruction cycle consists of four system clock cycles.

Instruction fetching and execution are pipelined in such a way that a fetch takes one instruction cycle while decoding and execution takes the next instruction cycle. However, the pipelining scheme causes each instruction to effectively execute in one cycle. If an instruction changes the program counter, two cycles are required to complete the instruction.

Program counter – PC

The 13-bit program counter (PC) controls the sequence in which the instructions stored in the program ROM are executed and its contents specify a maximum of 8192 addresses.

After accessing a program memory word to fetch an instruction code, the contents of the program counter are incremented by one. The program counter then points to the memory word containing the next instruction code.

When executing a jump instruction, conditional skip execution, loading PCL register, subroutine call, initial reset, internal interrupt, external interrupt or return from subroutine, the PC manipulates the program transfer by loading the address corresponding to each instruction.

The conditional skip is activated by instruction. Once the condition is met, the next instruction, fetched during the current instruction execution, is discarded and a dummy cycle replaces it to get the proper instruction. Otherwise proceed with the next instruction.

The lower byte of the program counter (PCL) is a readable and writeable register (06H). Moving data into the PCL performs a short jump. The destination will be within 256 locations.

When a control transfer takes place, an additional dummy cycle is required.

Program memory – ROM

The program memory, which contains executable program instructions, data and table information, is composed of a 16384 x 16 bit format. However as the PC (program counter) is comprised of only 13 bits, the remaining 1 ROM address bit is managed by dividing the program memory into 2 banks, each bank having a range between 0000H and 1FFFH. To move from the present ROM bank to a different ROM bank, the higher 1 bit of the ROM address are set by the BP (Bank Pointer), while the remaining 13 bits of the PC are set in the usual way by executing the appropriate jump or call instruction. As the full 14 address bits are latched during the execution of a call or jump instruction, the correct value of the BP must first be setup before a jump or call is executed. When either a software or hardware interrupt is received, note that no matter which ROM bank the pro-

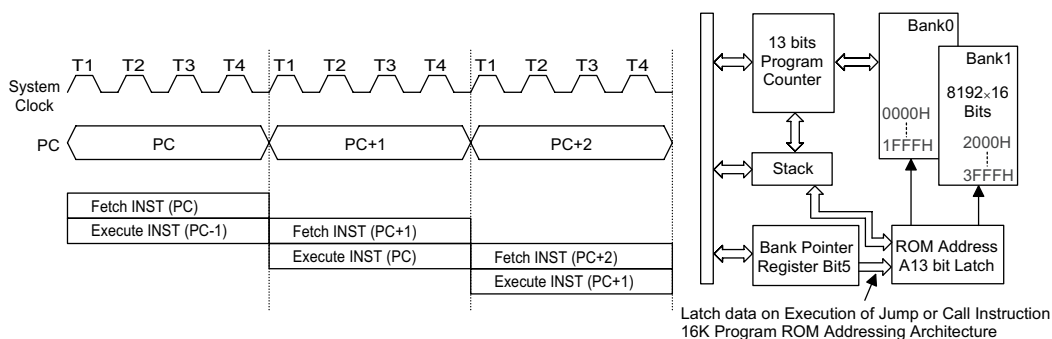

Execution flow

gram is in the program will always jump to the appropriate interrupt service address in Bank 0. The original full 14 bit address will be stored on the stack and restored when the relevant RET/RETI instruction is executed, automatically returning the program to the original ROM bank. This eliminates the need for programmers to manage the BP when interrupts occur.

Certain locations in Bank 0 of program memory are reserved for special usage:

- ROM Bank 0 (BP5~BP7=000B)
The ROM bank 0 ranges from 0000H to 1FFFH.
- Location 000H
This area is reserved for the initialization program. After chip reset, the program always begins execution at location 000H.
- Location 004H
This area is reserved for the external interrupt service program. If the INT input pin is activated, and the interrupt is enabled and the stack is not full, the program begins execution at location 004H.

- Location 008H
This area is reserved for the timer counter 0 interrupt service program. If a timer interrupt results from a timer counter 0 overflow, and if the interrupt is enabled and the stack is not full, the program begins execution at location 008H.

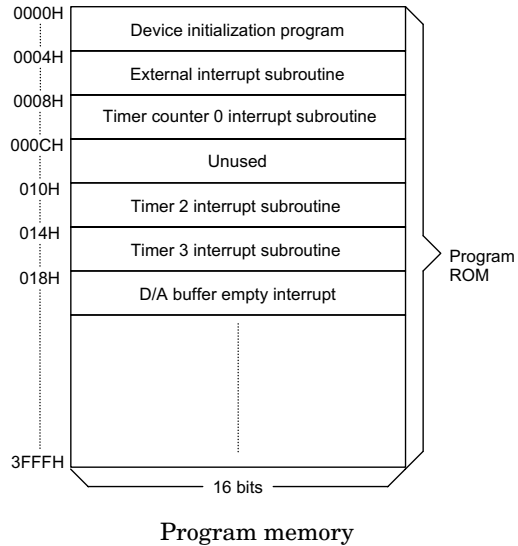

Mode	Program Rom Address													
	*13	*12	*11	*10	*9	*8	*7	*6	*5	*4	*3	*2	*1	*0
Initial reset	0	0	0	0	0	0	0	0	0	0	0	0	0	0
External interrupt	0	0	0	0	0	0	0	0	0	0	0	1	0	0
Timer counter 0 overflow	0	0	0	0	0	0	0	0	0	0	1	0	0	0
Timer 2 overflow	0	0	0	0	0	0	0	0	0	1	0	0	0	0
Timer 3 overflow	0	0	0	0	0	0	0	0	0	1	0	1	0	0
D/A buffer empty interrupt	0	0	0	0	0	0	0	0	0	1	1	0	0	0
Skip	PC+2													
Loading PCL	*13	*12	*11	*10	*9	*8	@7	@6	@5	@4	@3	@2	@1	@0
Jump, call branch	BP.5	#12	#11	#10	#9	#8	#7	#6	#5	#4	#3	#2	#1	#0
Return from subroutine	S13	S12	S11	S10	S9	S8	S7	S6	S5	S4	S3	S2	S1	S0

Program rom address

Note: *13~*0: Program ROM address
 @7~@0: PCL bits
 #12~#0: Instruction code bits

S13~S0: Stack register bits
 BP.5: Bit 5 of bank pointer (04H)

- Location 010H/014H
This area is reserved for the timer 2/3 interrupt service program. If a timer interrupt results from a timer 2/3 overflow, and if the interrupt is enabled and the stack is not full, the program begins execution at location 010H/014H.
- Location 018H
This area is reserved for the D/A buffer empty interrupt service program. After the system latch a D/A code at RAM address 28H, the interrupt is enable, and the stack is not full, the program begins execution at location 020H.
- Location 020H
For best condition, this is the starting location for writing the program..
- ROM Bank 1 (BP5~BP7=001B)
The range of the ROM starts from 2000H to 3FFFH.
- Table location
Any location in the ROM space can be used as look up tables. The instructions TABRDC [m] (use for any bank) and TABRDL [m] (only used for last page of program ROM) transfers the contents of the lower-order byte to the specified data memory, and the higher-order byte to TBLH (08H). Only the destination of the lower-order byte in the table is well-defined. The higher-order byte of the table word are transferred to the TBLH. The table higher-order byte register (TBLH) is read only. The table pointer (TBHP, TBLP) is a read/write register (1FH, 07H), which indicates the table location. Before accessing the table, the location must be placed in TBLP. The TBLH is read only and cannot be restored. If the main routine and the ISR (Interrupt Service Routine) both employ the table read instruction, the contents of the TBLH in

the main routine are likely to be changed by the table read instruction used in the ISR. Errors can occur. In other words, using the table read instruction in the main routine and the ISR simultaneously should be avoided. However, if the table read instruction has to be applied in both the main routine and the ISR, the interrupt is supposed to be disabled prior to the table read instruction. It will not be enabled until the TBLH has been backed up. All table related instructions need two cycles to complete the operation. These areas may function as normal program memory depending upon the requirements.

Stack register – STACK

This is a special part of the memory which is used to save the contents of the program counter (PC) only. The stack is organized into eight levels and is neither part of the data nor part of the program space, and is neither readable nor writeable. The activated level is indexed by the stack pointer (SP) and is neither readable nor writeable. At a subroutine call or interrupt acknowledgment, the contents of the program counter and ROM address A13 bit latch Data are pushed onto the stack. At the end of a subroutine or an interrupt routine, signaled by a return instruction (RET or RETI), the program counter and ROM address A13 bit latch Data are restored to its previous value from the stack. After a chip reset, the SP will point to the top of the stack.

If the stack is full and a non-masked interrupt takes place, the interrupt request flag will be recorded but the acknowledgment will be inhibited. When the stack pointer is decremented (by RET or RETI), the interrupt will be serviced. This feature prevents stack overflow allowing the pro-

Instruction(s)	Table Location													
	*13	*12	*11	*10	*9	*8	*7	*6	*5	*4	*3	*2	*1	*0
TABRDC [m]	#5	#4	#3	#2	#1	#0	@7	@6	@5	@4	@3	@2	@1	@0
TABRDL [m]	1	1	1	1	1	1	@7	@6	@5	@4	@3	@2	@1	@0

Table location

Note: @7~@0: TBLP register bit 7~bit 0
#5~#0: TBHP register bit 13~bit 8

*13~*0: Current Program ROM table address bit 13~bit 0

grammer to use the structure more easily. In a similar case, if the stack is full and a CALL is subsequently executed, stack overflow occurs and the first entry will be lost (only the most recent eight return address are stored).

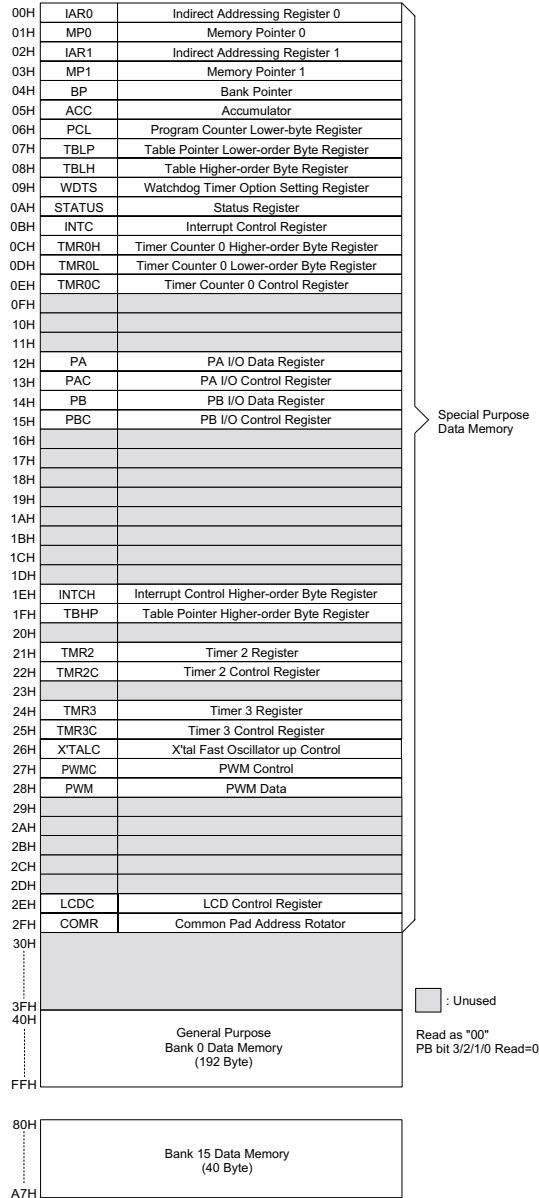

RAM mapping

Data memory – RAM

- Bank 0 (BP4~BP0=00000)

The Bank 0 data memory includes special purpose and general purpose memory. The special purpose memory is addressed from 00H to 2FH, while general purpose memory is addressed from 40H to FFH. All data memory areas can handle arithmetic, logic, increment, decrement and rotate operations directly. Except for some dedicated bits, each bit in the data memory can be set and reset by the SET [m].i and CLR [m].i instructions, respectively. They are also indirectly accessible through the memory pointer registers (MP0;01H, MP1;03H).
- Bank 15 (BP4~BP0=01111B)

The range of RAM starts from 80H to A7H. On the LCD, every bit stands for one dot. If the bit is "1", the light of the dot on the LCD will be turned on. If the bit is "0", then it will be turned off. Only MP1 can deal with the memory of this range.

The contrast form of RAM location, COMMON, and SEGMENT is as follows.

Indirect addressing register

Location 00H and 02H are indirect addressing registers that are not physically implemented. Any read/write operation of [00H] and [02H] access data memory are pointed to by MP0 (01H) and MP1 (03H) respectively. Reading location 00H or 02H indirectly will return the result 00H. Writing indirectly results in no operation. The function of data movement between two indirect addressing registers, is not supported. The memory pointer registers, MP0 and MP1, are 8-bit registers which can be used to access the data memory by combining corresponding indirect addressing registers but Bank 15 can use MP1 only.

Accumulator

The accumulator is closely related to ALU operations. It is also mapped to location 05H of the data memory and it can carry out immediate data operations. The data movement between two data memories has to pass through the accumulator.

LCD driver output

The maximum output number of the HTG2150 LCD driver is 8×40. The LCD driver bias type is "R" type, no external capacitor is required and the bias voltage is 1/4 bias. Some of the Segment outputs share pins with another pins, PB4~PB7 (SEG33~SEG36), INT (SEG37), XOUT (SEG38), XIN (SEG39). Whether segment output or I/O pin can individually be decided by mask option.

LCD driver output can be enabled or disabled by setting the LCD (bit 6 of LCDC; 2EH) without the influence of the related memory condition. There is a special function for LCD display, which is Rotate function. There are 8 kinds of Rotate function, (user can change the data of the SS0 to SS3.)

An example of an lcd driving waveform (1/8 duty, 1/4 bias) is shown below.

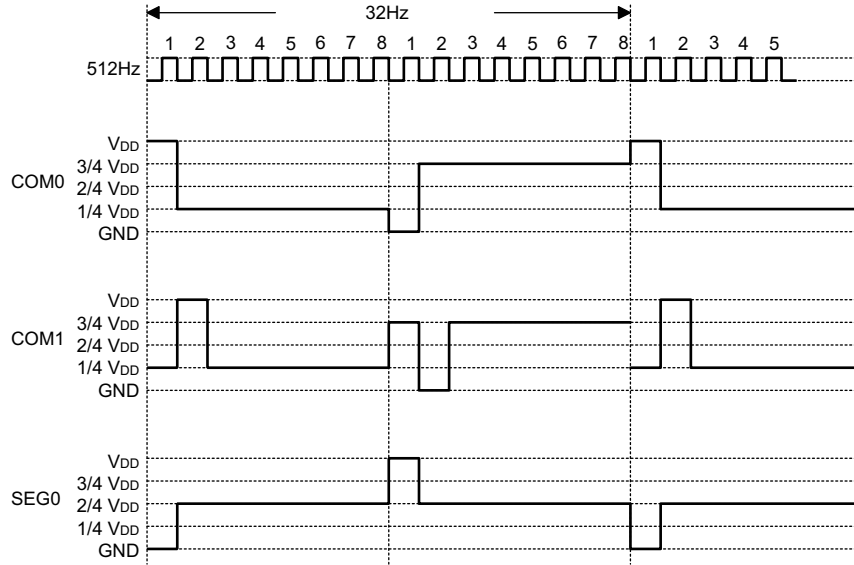

LCD display memory: (Bank 15)

Address	80H	81H	82H	83H	84H	85H.....91H	92H	A7H
COM0	Bit0										
COM1	Bit1										
COM2	Bit2										
COM3	Bit3										
COM4	Bit4										
COM5	Bit5										
COM6	Bit6										
COM7	Bit7										
	SEG0	SEG1	SEG2	SEG3	SEG4	SEG5.....SEG17	SEG18	SEG39

Register	Bit No.	Label	Function
LCDC	0~5	—	Can R/W (Default 000000B)
	6	LCD	Control the LCD output (0=disable; 1=enabled) (Default=1)
	7	RC	LCD clock source select (Default=0) 1= 32768Hz crystal 0= system clock

LCDC register

Rotate				Description
SSL3	SSL2	SSL1	SSL0	
x	0	0	0	The Pad of common 0 is connected to common 0 and the Pad of common 1 is connected to common 1 and so on.
x	0	0	1	The Pad of common 0 is connected to common 1 and the Pad of common 1 is connected to common 2 and so on.
x	0	1	0	The Pad of common 0 is connected to common 2 and the Pad of common 1 is connected to common 3 and so on.
x	0	1	1	The Pad of common 0 is connected to common 3 and the Pad of common 1 is connected to common 4 and so on.
x	1	0	0	The Pad of common 0 is connected to common 4 and the Pad of common 1 is connected to common 5 and so on.
x	1	0	1	The Pad of common 0 is connected to common 5 and the Pad of common 1 is connected to common 6 and so on.
x	1	1	0	The Pad of common 0 is connected to common 6 and the Pad of common 1 is connected to common 7 and so on.
x	1	1	1	The Pad of common 0 is connected to common 7 and the Pad of common 1 is connected to common 0 and so on.

2FH register

Arithmetic and logic unit – ALU

This circuit performs 8-bit arithmetic and logic operation. The ALU provides the following functions:

- Arithmetic operations (ADD, ADC, SUB, SBC, DAA)
- Logic operations (AND, OR, XOR, CPL)
- Rotation (RL, RR, RLC, RRC)
- Increment and Decrement (INC, DEC)
- Branch decision (SZ, SNZ, SIZ, SDZ)

The ALU not only saves the results of a data operation but also changes the status register.

Status register – STATUS

This 8-bit register (0AH) contains the zero flag (Z), carry flag (C), auxiliary carry flag (AC), overflow flag (OV), power down flag (PD) and watchdog time-out flag (TO). It also records the status information and controls the operation sequence.

With the exception of the TO and PD flags, bits in the status register can be altered by instructions like any other register. Any data written into the status register will not change the TO or PD flags. In addition it should be noted that operations related to the status register may

give different results from those intended. The TO and PD flags can only be changed by system power up, Watchdog Timer overflow, executing the HALT instruction and clearing the Watchdog Timer.

The Z, OV, AC and C flags generally reflect the status of the latest operations.

In addition, on entering the interrupt sequence or executing the subroutine call, the status register will not be automatically pushed onto the stack. If the contents of status are important and if the subroutine can corrupt the status register, precautions must be taken to save it properly.

Interrupt

The HTG2150 provides an external interrupt and a PWM D/A interrupt and internal timer interrupts. The Interrupt Control register (INTC;0BH, INTCH;1EH) contains the interrupt control bits to set the enable/disable and the interrupt request flags.

Once an interrupt subroutine is serviced, all other interrupts will be blocked (by clearing the EMI bit). This scheme may prevent any further interrupt nesting. Other interrupt requests may happen during this interval but only the inter-

Labels	Bits	Function
C	0	C is set if the operation results in a carry during an addition operation or if a borrow does not take place during a subtraction operation; otherwise C is cleared. C is also affected by a rotate through carry instruction.
AC	1	AC is set if the operation results in a carry out of the low nibbles in addition or no borrow from the high nibble into the low nibble in subtraction; otherwise AC is cleared.
Z	2	Z is set if the result of an arithmetic or logic operation is zero; otherwise Z is cleared.
OV	3	OV is set if the operation results in a carry into the highest-order bit but not a carry out of the highest-order bit, or vice versa; otherwise OV is cleared.
PD	4	PD is cleared when either a system powers up or a CLR WDT instruction is executed. PD is set by executing the HALT instruction.
TO	5	TO is cleared by a system power-up or executing the CLR WDT or HALT instruction. TO is set by a WDT time-out.
—	6, 7	Undefined bits, read as "0".

Status register

rupt request flag is recorded. If a certain interrupt needs servicing within the service routine, the programmer may set the EMI bit and the corresponding bit of the INTC to allow interrupt nesting. If the stack is full, the interrupt request will not be acknowledged, even if the related interrupt is enabled, until the SP is decremented. If immediate service is desired, the stack must be prevented from becoming full.

All these kinds of interrupt have a wake-up capability. As an interrupt is serviced, a control transfer occurs by pushing the program counter and A13 bit onto the stack followed by a branch to subroutines at specified locations in the program memory. Only the program counter and A13 bit are pushed onto the stack. If the contents of the register and Status register (STATUS) are altered by the interrupt service program which corrupt the desired control sequence, the contents should be saved first.

External interrupt is triggered by a high to low transition of INT and the related interrupt request flag (EIF; bit 4 of INTC) will be set. When the interrupt is enabled, and the stack is not full and the external interrupt is active, a subroutine call to location 04H will occur. The interrupt request flag (EIF) and EMI bits will be cleared to disable other interrupts.

The internal timer counter 0 interrupt is initialized by setting the timer counter 0 interrupt

request flag (TOF; bit 5 of INTC), resulting from a timer 0 overflow. When the interrupt is enabled, and the stack is not full and the TOF bit is set, a subroutine call to location 08H will occur. The related interrupt request flag (TOF) will be reset and the EMI bit cleared to disable further interrupts.

The Timer 2/3 interrupts are operated in the same manner as timer 0. While ET2I/ET3I and T2F/T3F are the related control bits and the related request flags of TMR2/TMR3, which locate at bit0/bit1 and bit4/bit5 of the INTCH respectively.

During the execution of an interrupt subroutine, other interrupt acknowledgments are held until the RETI instruction is executed or the EMI bit and the related interrupt control bit are set to 1 (if the stack is not full). To return from the interrupt subroutine, the RET or RETI instruction may be invoked. RETI will set the EMI bit to enable an interrupt service, but RET will not.

Interrupts occurring in the interval between the rising edges of two consecutive T2 pulses, will be serviced on the latter of the two T2 pulses, if the corresponding interrupts are enabled. In the case of simultaneous requests the priorities applied are shown in the following table. These can be masked by resetting the EMI bit.

Register	Bit No.	Label	Function
INTC	0	EMI	Controls the (global) interrupt (1=enable; 0=disable)
	1	E EI	Controls the external interrupt (1=enable; 0=disable)
	2	ET0I	Controls the timer counter 0 interrupt (1=enable; 0=disable)
	3	—	Unused bit
	4	EIF	External interrupt request flag (1=active; 0=inactive)
	5	TOF	Internal timer counter 0 request flag (1=active; 0=inactive)
	6, 7	—	Unused bit

INTC register

Register	Bit No.	Label	Function
INTCH	0	ET2I	Controls the Timer 2 interrupt (1=enable; 0=disable)
	1	ET3I	Controls the Timer 3 interrupt (1=enable; 0=disable)
	2	PWMI	PWM D/A interrupt (1=enable; 0=disable)
	3	—	Should be set as "0" always
	4	T2F	Internal Timer 2 request flag (1=active; 0=inactive)
	5	T3F	Internal Timer 3 request flag (1=active; 0=inactive)
	6	PWMF	PWM D/A flag (1=active; 0=inactive)
	7	—	Should be set as "0" always

INTCH register

No.	Interrupt Source	Priority	Vector
a	External interrupt	1	04H
b	Timer counter 0 overflow	2	08H
d	Timer 2 overflow	4	10H
e	Timer 3 overflow	5	14H
f	PWM D/A interrupt	6	18H

The timer counter 0 and Timer 2/3 interrupt request flag (T0F/T2F/T3F), External interrupt request flag (EIF), PWM D/A interrupt request flag (PWMF), Enable Timer 0/2/3 bit (ET0I/ET2I/ET3I), Enable PWM D/A interrupt (PWMI), Enable external interrupt bit (EEL) and Enable master interrupt bit (EMI) constitute an interrupt control register (INTC/INTCH) which is located at 0BH/1EH in the data memory. EMI, EEL, ET0I, ET2I, ET3I, PWMI are used to control the enabling/disabling of interrupts. These bits prevent the requested interrupt from being serviced. Once the interrupt request flags (T0F, T2F, T3F, EIF, PWMF) are set, they will remain in the INTC/INTCH register until the interrupts are serviced or cleared by a software instruction.

It is recommended that a program does not use the "CALL subroutine" within the interrupt subroutine. Interrupts often occur in an unpredictable manner or need to be serviced immediately in some applications. If only one stack is left

and enabling the interrupt is not well controlled, the "CALL subroutine" should not operate in the interrupt subroutine as it will damage the original control sequence.

Oscillator configuration

There are two oscillator circuits in the HTG2150.

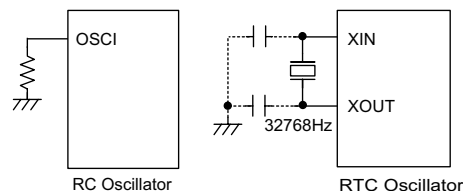

System and RTC oscillator

The RC oscillator signal provides the internal system clock. The HALT mode stops the system oscillator and ignores any external signal to conserve power. Only the RC oscillator is designed to drive the internal system clock. The RTC oscillator provides the Timer 3 and LCD driver clock source.

The RC oscillator needs an external resistor connected between OSCI and VSS. The resistance value must range from 50kΩ to 400kΩ. However, the frequency of the oscillation may vary with V_{DD} , temperature and the chip itself due to process variations. It is, therefore, not suitable for timing sensitive operations where accurate oscillator frequency is desired.

There is another oscillator circuit designed for the real time clock. In this case, only the 32768Hz crystal can be applied. The crystal should be connected between XIN and XOUT, and two external capacitors are required for the oscillator circuit in order to get a stable frequency.

The RTC oscillator is used to provide clock source for the LCD driver and Timer 3. It can be enabled or disabled by mask option.

The WDT oscillator is a free running on-chip RC oscillator, requiring no external components. Even if the system enters the power down mode, and the system clock is stopped, the WDT oscillator still runs with a period of approximately 78 μ s. The WDT oscillator can be disabled by mask option to conserve power.

Watchdog Timer – WDT

The WDT clock source is implemented by a dedicated RC oscillator (WDT oscillator). This timer is designed to prevent a software malfunction or sequence jumping to an unknown location with unpredictable results. The Watchdog Timer can be disabled by mask option. If the Watchdog Timer is disabled, all the executions related to WDT result in no operation.

When the internal WDT oscillator (RC oscillator with 83 μ s period normally) is enable, it is first divided by 256 (8 stages) to get the nominal time-out period of approximately 21ms. This time-out period may vary with temperature, V_{DD} and process variations. By invoking the WDT prescaler, longer time-out periods can be realized. Writing data to WS2, WS1, WS0 (bits 2,1,0 of the WDTS) can give different time-out periods. If WS2, WS1, WS0 are all equal to 1, the division ratio is up to 1:128, and the maxi-

imum time-out period is 2.6 seconds.

WS2	WS1	WS0	Division Ratio
0	0	0	1:1
0	0	1	1:2
0	1	0	1:4
0	1	1	1:8
1	0	0	1:16
1	0	1	1:32
1	1	0	1:64
1	1	1	1:128

WDTS register

The WDT overflow under normal operation will initialize "chip reset" and set the status bit TO. Whereas in the HALT mode, the overflow will initialize a "warm reset" only the PC and SP are reset to zero. To clear the WDT contents (including the WDT prescaler), three methods are adopted; external reset (a low level to \overline{RES}), software instructions, or a HALT instruction. The software instruction is "CLR WDT", execution of the CLR WDT instruction will clear the WDT.

Power down operation – HALT

The HALT mode is initialized by the HALT instruction and results in the following...

- The system oscillator will turn off but the WDT oscillator keeps running (if the WDT oscillator is selected).
- The contents of the on-chip RAM and registers remain unchanged.
- WDT and WDT prescaler will be cleared and do recounting again.

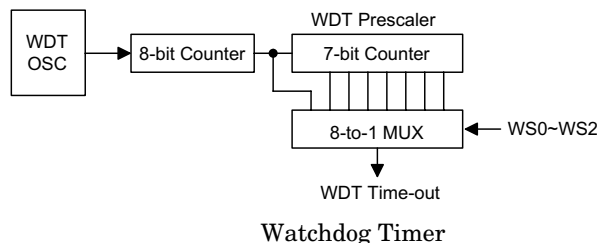

- All I/O ports maintain their original status.
- The PD flag is set and the TO flag is cleared.

The system can leave the HALT mode by means of an external reset, an interrupt, an external falling edge signal on port A or a WDT overflow. An external reset causes a device initialization and the WDT overflow performs a "warm reset". By examining the TO and PD flags, the reason for chip reset can be determined. The PD flag is cleared when the system powers up or upon executing the CLR WDT instruction and is set when the HALT instruction is executed. The TO flag is set if the WDT time-out occurs, and causes a wake-up that only resets the PC and SP, the others maintain their original status.

The port A wake-up and interrupt methods can be considered as a continuation of normal execution. Each bit in port A can be independently selected to wake up the device by mask option. Awakening from an I/O port stimulus, the program will resume execution of the next instruction. If awakening from an interrupt, two sequences may happen. If the related interrupt is disabled or the interrupt is enabled but the stack is full, the program will resume execution at the next instruction. If the interrupt is enabled and the stack is not full, the regular interrupt response takes place.

Once a wake-up event occurs, it takes $1024 t_{SYS}$ (system clock period) to resume normal operation. In other words, a dummy cycle period will be inserted after the wake-up. If the wake-up results from an interrupt acknowledge, the actual interrupt subroutine will be delayed by one more cycle. If the wake-up results in the next instruction execution, this will be executed immediately after a dummy period has finished. If an interrupt request flag is set to "1" before entering the HALT mode, the wake-up function of the related interrupt will be disabled.

To minimize power consumption, all I/O pins should be carefully managed before entering the HALT status.

Reset

There are three ways in which a reset can occur:

- \overline{RES} reset during normal operation
- \overline{RES} reset during HALT
- WDT time-out reset during normal operation

The WDT time-out during HALT is different from other chip reset conditions, since it can perform a "warm reset" that just resets the PC and SP, leaving the other circuits in their original state. Some registers remain unchanged during other reset conditions. Most registers are reset to the "initial condition" when the reset conditions are met. By examining the PD and TO flags, the program can distinguish between different "chip resets".

TO	PD	RESET Conditions
0	0	\overline{RES} reset during power-up
u	u	\overline{RES} reset during normal operation
0	1	\overline{RES} wake-up HALT
1	u	WDT time-out during normal operation
1	1	WDT wake-up HALT

Note: "u" means "unchanged"

To guarantee that the system oscillator has started and stabilized, the SST (System Start-up Timer) provides an extra-delay of 1024 system clock pulses when the system powers up or awakes from the HALT state.

When a system power-up occurs, the SST delay is added during the reset period. But when the reset comes from the \overline{RES} pin, the SST delay is disabled. Any wake-up from HALT will enable the SST delay.

The functional unit chip reset status are shown below.

PC	000H
Interrupt	Disable
Prescaler	Clear
WDT	Clear. After master reset, WDT begins counting
Timer (0/2/3)	Off
LCD Display	Enable
Pull-high of RESB	with
Input/output Ports	Input mode
SP	Points to the top of the stack

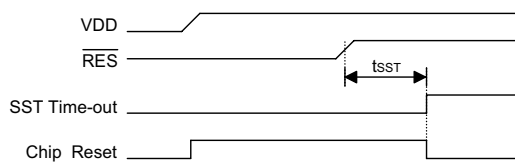

Reset timing chart

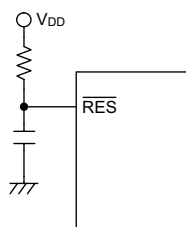

Reset circuit

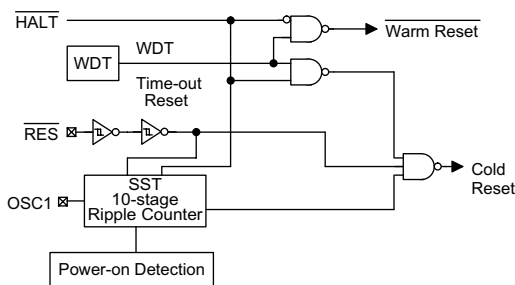

Reset configuration

Timer 0

The timer 0 contains 16-bit programmable count-up counters and the clock source come from the system clock divided by 4.

There are three registers related to timer counter 0; TMR0H (0CH), TMR0L (0DH), TMR0C (0EH). Writing TMR0L only writes the data into a low byte buffer, and writing TMR0H will write the data and the contents of the low byte buffer into the timer 0 preload register (16-bit) simultaneously. The timer 0 preload register is changed by writing TMR0H operations and writing TMR0L will keep the timer 0 preload register unchanged.

Reading TMR0H will also latch the TMR0L into the low byte buffer to avoid the false timing problem. Reading TMR0L returns the contents of the low byte buffer. In other words, the low byte of timer counter 0 cannot be read directly. It must read the TMR0H first to make the low byte contents of timer 0 be latched into the buffer.

The TMR0C is the timer 0 control register, which defines the timer 0 options.

The timer counter control registers define the operating mode, counting enable or disable and active edge.

If the timer counter starts counting, it will count from the current contents in the timer counter to FFFFH. Once an overflow occurs, the counter is reloaded from the timer counter preload register and generates the corresponding interrupt request flag (TOF; bit of INTC) at the same time.

To enable the counting operation, the Timer ON bit (TON; bit 4 of TMR0C) should be set to 1. The overflow of the timer counter is one of the wake-up sources. No matter what the operation mode is, writing a 0 to ET0I can disable the corresponding interrupt service.

In the case of timer counter OFF condition, writing data to the timer counter preload register will also reload that data to the timer counter. But if the timer counter is turned on, data written to the timer counter will only be kept in the timer counter preload register. The timer counter will still operate until overflow occurs.

The state of the registers is summarized in the following table:

Register	Reset (Power On)	WDT Time-out (Normal Operation)	$\overline{\text{RES}}$ Reset (Normal Operation)	$\overline{\text{RES}}$ Reset (HALT)	WDT Time-out (HALT)
TMR0H	xxxx xxxx	uuuu uuuu	uuuu uuuu	uuuu uuuu	uuuu uuuu
TMR0L	xxxx xxxx	uuuu uuuu	uuuu uuuu	uuuu uuuu	uuuu uuuu
TMR0C	00-0 1---	00-0 1---	00-0 1---	00-0 1---	uu-u u---
TMR2	xxxx xxxx	uuuu uuuu	uuuu uuuu	uuuu uuuu	uuuu uuuu
TMR2C	00-0 1000	00-0 1000	00-0 1000	00-0 1000	uu-u uuuu
TMR3	xxxx xxxx	uuuu uuuu	uuuu uuuu	uuuu uuuu	uuuu uuuu
TMR3C	00-0 1000	00-0 1000	00-0 1000	00-0 1000	uu-u uuuu
INTCH	0000 0000	0000 0000	0000 0000	0000 0000	uuuu uuuu
TBHP	xxxx xxxx	uuuu uuuu	uuuu uuuu	uuuu uuuu	uuuu uuuu
Program Counter	0000H	0000H	0000H	0000H	0000H*
MP0	xxxx xxxx	uuuu uuuu	uuuu uuuu	uuuu uuuu	uuuu uuuu
MP1	xxxx xxxx	uuuu uuuu	uuuu uuuu	uuuu uuuu	uuuu uuuu
ACC	xxxx xxxx	uuuu uuuu	uuuu uuuu	uuuu uuuu	uuuu uuuu
TBLP	xxxx xxxx	uuuu uuuu	uuuu uuuu	uuuu uuuu	uuuu uuuu
TBLH	xxxx xxxx	uuuu uuuu	uuuu uuuu	uuuu uuuu	uuuu uuuu
STATUS	--00 xxxx	--1u uuuu	--uu uuuu	--01 uuuu	--11 uuuu
BP	0000 0000	0000 0000	0000 0000	0000 0000	uuuu uuuu
LCDC	0100 0000	0100 0000	0100 0000	0100 0000	uuuu uuuu
INTC	0000 0000	0000 0000	0000 0000	0000 0000	uuuu uuuu
WDTS	0000 0111	0000 0111	0000 0111	0000 0111	uuuu uuuu
PA	1111 1111	1111 1111	1111 1111	1111 1111	uuuu uuuu
PAC	1111 1111	1111 1111	1111 1111	1111 1111	uuuu uuuu
PB	1111 0000	1111 0000	1111 0000	1111 0000	uuuu uuuu
PBC	1111 0000	1111 0000	1111 0000	1111 0000	uuuu 0000
COMR	0000 0000	0000 0000	0000 0000	0000 0000	uuuu uuuu
PWMC	1111 1111	1111 1111	1111 1111	1111 1111	uuuu uuuu
PWM	xxxx xxxx	xxxx xxxx	xxxx xxxx	xxxx xxxx	uuuu uuuu
X'TALC	0000 0000	0000 0000	0000 0000	0000 0000	uuuu uuuu

Note: "*" means "warm reset"
 "u" means "unchanged"
 "x" means "unknown"

Label	Bits	Function
—	0~2	Unused bits, read as "0".
TE	3	To define the TMR0 active edge of the timer counter (0=active on low to high; 1=active on high to low)
TON	4	To enable/disable timer counting (0=disabled; 1=enabled)
—	5	Unused bits, read as "x".
TM0, TM1	6, 7	0, 1=Internal clock

TMR0C register

When the timer counter (reading TMR0H) is read, the clock will be blocked to avoid errors. As this may results in a counting error, this must be taken into consideration by the programmer.

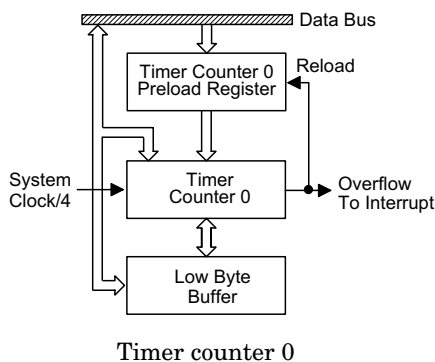

Timer 2/3

Timer 2 is an 8-bit counter, and its clock source comes from the system clock divided by an 8-stage prescaler. There are two registers related to Timer 2 ; TMR2 (21H) and TMR2C (22H). Two physical registers are mapped to TMR2 location; writing TMR2 makes the starting value be placed in the Timer 2 preload register and reading the TMR2 gets the contents of the Timer 2 counter. The TMR2C is a control register, which defines the division ratio of the prescaler and counting enable or disable.

Writing data to B2, B1 and B0 (bits 2, 1, 0 of TMR2C) can yield various clock sources.

Once the Timer 2 starts counting, it will count from the current contents in the counter to

FFH. Once an overflow occurs, the counter is reloaded from a preload register, and generates an interrupt request flag (T2F; bit 4 of INTCH). To enable the counting operation, the timer On bit (TON; bit 4 of TMR2C) should be set to "1". For proper operation, bit 6 of TMR2C should be set to "1" and bit 3, bit7 should be set to "0".

The Timer 2 can also be used as PFD output by setting PWM1 and PWM2 to be PFD and PFDB output respectively by 2FH.7 and 2FH.6. When the PFD/PFDB function is selected, setting 2FH.4/2FH.5 to "1" will enable the PFD/PFDB output and setting 2FH.4/2FH.5 to "0" will disable the PFD/PFDB output. PFD Frequency: $T2f/[256-TMR2] \times 2$

Timer 3 has the same structure and operating manner with Timer 2, except for clock source and PFD function. The Timer 3 can be used as a time base to generate a regular internal interrupt. The clock source of Timer 3 can come from RTC OSC (X'TAL 32kHz) or system clock divided by an 8-stage prescaler. If the RTC mask option is enabled, a 32kHz crystal is needed across XIN and XOUT pins. The 32kHz signal is processed by an 8-stage prescaler to yield various counting clock for Timer 3. There are 2 registers related to Timer 3; TMR3 (24H) and TMR3C (25H). Writing data to B2, B1, B0 (bit 2, 1, 0 of TMR3C) can yield various counting clock.

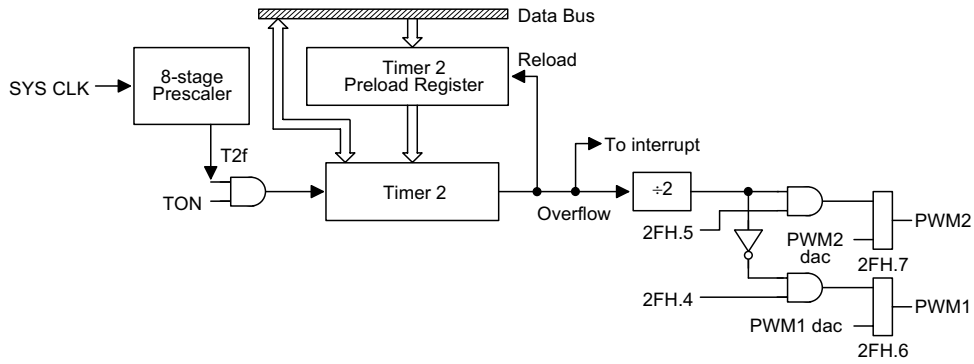

Timer 2

Label	Bits	Function
SSL 3~0	3~0	LCD common used
PFDB	4	To enable/disable PFDB output (0=disable; 1=enable)
PWM1	6	To select PFDB/PWM1 output (0=PWM1; 1=PFDB)
PWM2	7	To select PFD/PWM2 output (0=PWM2; 1=PFD)

2FH register

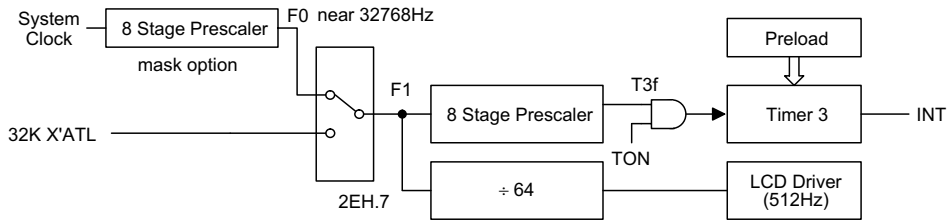

Timer 3

TMR2C			T2f
Bit 2	Bit 1	Bit 0	
0	0	0	SYS CLK/2
0	0	1	SYS CLK/4
0	1	0	SYS CLK/8
0	1	1	SYS CLK/16
1	0	0	SYS CLK/32
1	0	1	SYS CLK/64
1	1	0	SYS CLK/128
1	1	1	SYS CLK/256

TMR2C bit 4 to enable/disable timer counting
(0=disable;1=enable)

TMR2C bit 3 always write "0"

TMR2C bit 5 always write "0"

TMR2C bit 6 always write "1"

TMR2C bit 7 always write "0"

F1 can select 4 frequency by mask option

Auto Mask Option	F0
SYS CLK near 512kHz	SYS CLK/16
SYS CLK near 1024kHz	SYS CLK/32
SYS CLK near 2048kHz	SYS CLK/64
SYS CLK near 4096kHz	SYS CLK/128

TMR3C			T3f
Bit 2	Bit 1	Bit 0	
0	0	0	F1/2
0	0	1	F1/4
0	1	0	F1/8
0	1	1	F1/16
1	0	0	F1/32
1	0	1	F1/64
1	1	0	F1/128
1	1	1	F1/256

Time base frequency= T3f / (256 - TMR3)

TMR3C bit 4 to enable/disable timer counting
(0=disable; 1=enable)

TMR3C bit 3 always write "0"

TMR3C bit 5 always write "0"

TMR3C bit 6 always write "1"

TMR3C bit 7 always write "0"

Input/output ports

There are 12 bidirectional input/output lines in the HTG2150, labeled PA and PB, which are mapped to the data memory of [12H], [14H], respectively. All these I/O ports can be used for input and output operations. For input operation, these ports are non-latching, that is, the inputs must be ready at the T2 rising edge of instruction MOV A,[m] (m=12H, 14H). For output operation, all data is latched and remains unchanged until the output latch is rewritten.

Each I/O line has its own control register (PAC, PBC) to control the input/output configuration. With this control register, CMOS output or schmitt trigger input with or without pull-high resistor (mask option) structures can be reconfigured dynamically under software control. To function as an input, the corresponding latch of the control register must write "1". The pull-high resistance will exhibit automatically if the pull-high option is selected. The input source also depends on the control register. If the control register bit is "1", the input will read the pad state. If the control register bit is "0", the contents of the latches will move to the internal bus. The latter is possible in "read-modify-write" instruction. For output function, CMOS is the only configuration. These control registers are mapped to locations 13H, 15H.

After a chip reset, these input/output lines stay at high levels or floating (mask option). Each bit of these input/output latches can be set or cleared by the SET [m].i or CLR [m].i (m=12H, 14H) instruction.

Some instructions first input data and then follow the output operations. For example, the SET [m].i, CLR [m].i, CPL [m] and CPLA [m] instructions read the entire port states into the CPU, execute the defined operations (bit-operation), and then write the results back to the latches or the accumulator.

Each line of port A has the capability to wake-up the device. Port B are share pad, each pin function are defined by mask option, the PB7 shares with SEG36. The PB6, PB5 and PB4 share with SEG35, SEG34 and SEG33. If the segment output is selected, the related I/O register (PB) cannot be used as general purpose register. Reading the register will result to an unknown state.

PWM interface

The HTG2150 provides an 8 bit (bit 7 is a sign bit) PWM D/A interface, which is good for speech synthesis. The user can record or synthesize the sound and digitize it into the program ROM. These sound could be played back in sequence of the functions as designed by the internal program ROM. There are several algorithms that can be used in the HTG2150, they are ... PCM, μ LAW, DPCM, ADPCM.....

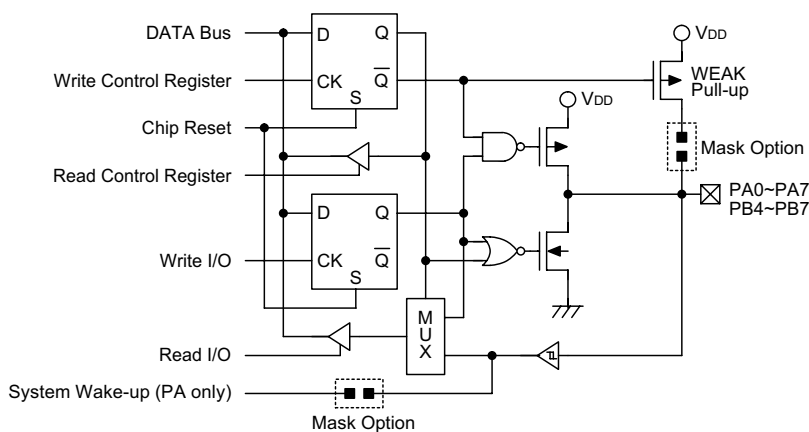

Input/output ports

The PWM circuit provides two pad outputs: PWM2, PWM1 which can directly drive a piezo or a 32Ω speaker without adding any external element. Refer to the Application Circuits.

The PWM clock source comes from the system clock divided by a 3-bit prescaler. Setting data to P0, P1 and P2 (bit 3, 4, 5 of 27H) can yield various clock sources. The clock source are use for PWM modulating clock and sampling clock. After setting the start bit (bit 0 27H) and the next falling edge coming from the prescaler, the "DIV" will generate a serial clock to PWM counter for modulating and PWMI for interrupt. The PWM counter latch data at the first "F1" clock falling edge and the start counter at "F1" rising edge. The "F2" clock is synchronous with the first "F1" clock and it is also connected to the PWM output latch. In setting the "start bit" initial status, the "PWM1 DAC" outputs a "high" level and change the output status to "LOW" while the "7 bits counter" overflows.

BZ/SP	6/7 Bit	F1	F2 (Sampling Rate)	Device
0	0	F0	F0/64	32Ω speaker
0	1	F0	F0/128	32Ω speaker
1	0	F0	F0/64	Buzzer/8Ω speaker
1	1	F0	F0/128	Buzzer/8Ω speaker

Note: F1: for PWM modulation clock and F2 for sampling clock.
 F0: system /[n+1] n=0~7
 (n:3 bits preload counter)

On the above table, we can easily see that the sampling rate is dependent on the system clock. If start bit is set to "0", the PWM2 and PWM1 will output a GND level voltage.

Label	Bits	Function
D/A	0	D/A control. 0:start ; 1:stop
BZ/SP	1	Output driver select 1:Buzzer ; 0:speaker
Bit	2	PWM counter bit select 1:7 bits ; 0:6 bits
P0~P2	3~5	3 bits preload counter, bit 5/4/3:000B~111B (0~7) bit 3:LSB
D0, D1	6, 7	PWMI

D0	D1	Samping Time/PWM Interrupt
0	0	1
0	1	2
1	0	4
1	1	8

PWM control register

	bit0	bit1	bit2	bit3	bit4	bit5	bit6	bit7
7 bit	D0	D1	D2	D3	D4	D5	D6	D7
6 bit	X	D1	D2	D3	D4	D5	D6	D7

Note: X means don't care.
 bit7: Sign bit

PWM data buffer

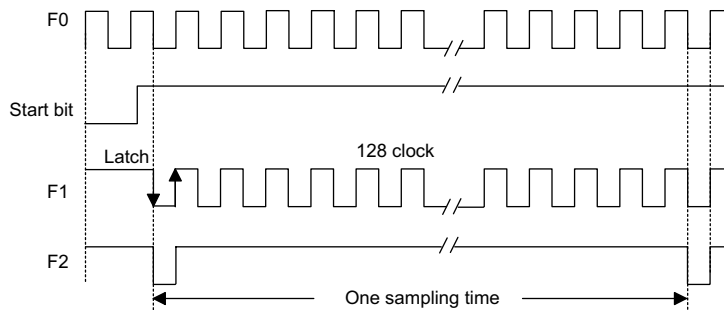

7 bits PWM counter bit

Mask option

The following shows many kinds of mask options in the HTG2150. All the mask options must be defined on order to ensure proper system functioning.

No.	Mask Option
1	WDT enable/disable selection. WDT can be enabled or disabled by mask option.
2	Wake-up selection. This option defines the wake-up activity. External I/O pins (PA only) all have the capability to wake-up the chip from a HALT mode by a following edge.
3	External interrupt input pin share with other function selection. INT/SEG37: INT can be set as an external interrupt input pin or LCD segment output pin.
4	I/O pins share with other function selection. PB4/SEG33, PB5/SEG34, PB6/SEG35, PB7/SEG36: PB4, PB5, PB6, PB7 can be set as I/O pins or LCD segment output pins.
5	Segment output pins share with other function selection. XIN/SEG39, XOUT/SEG38: SEG38, SEG39 can be set as LCD segment output pins or XIN, XOUT pins be connected to a 32768Hz crystal.
6	LCD bias register selection. This option describes the LCD bias current. There are three types of selection. * <ul style="list-style-type: none"> • Selectable as small, middle or large current.

Note: * **Small current**

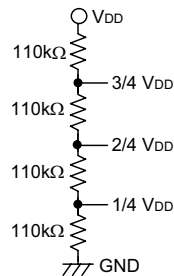

Middle current

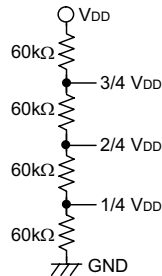

Large current

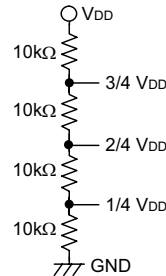

Application Circuits

32Ω speaker/Buzzer application

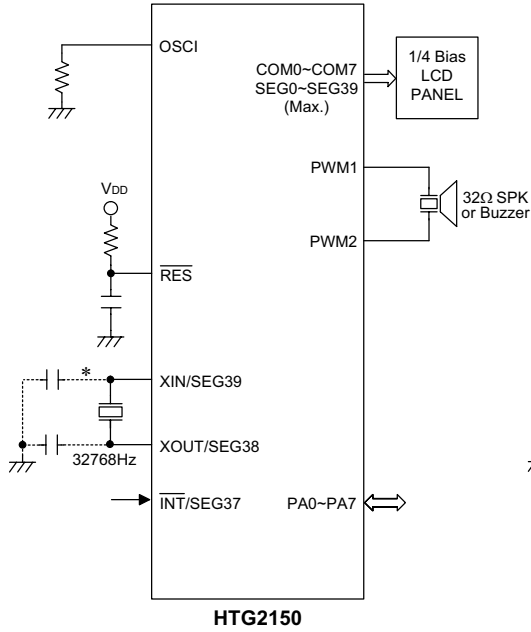

8Ω speaker application

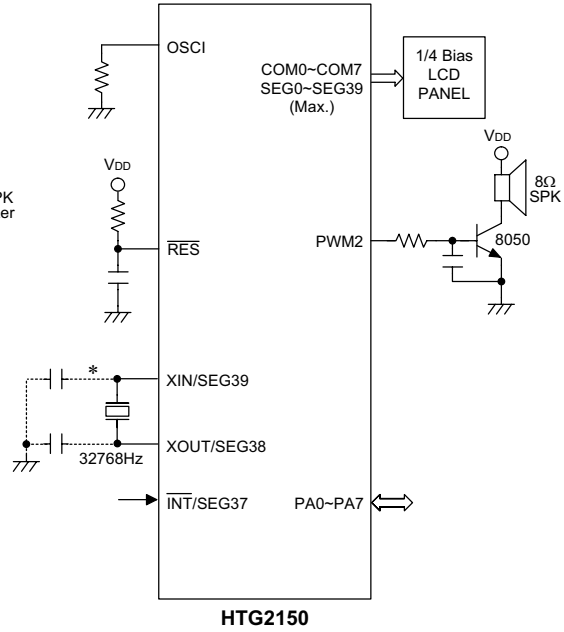

Note: * Optional capacitors can be added to get a more accurate frequency. Since each crystal has its own characteristics, the user should consult the crystal manufacturer for appropriate value of the external capacitors.

Instruction Set Summary

Mnemonic	Description	Instruction Cycle	Flag Affected
Arithmetic			
ADD A,[m]	Add data memory to ACC	1	Z,C,AC,OV
ADDM A,[m]	Add ACC to data memory	1 ⁽¹⁾	Z,C,AC,OV
ADD A,x	Add immediate data to ACC	1	Z,C,AC,OV
ADC A,[m]	Add data memory to ACC with carry	1	Z,C,AC,OV
ADCM A,[m]	Add ACC to register with carry	1 ⁽¹⁾	Z,C,AC,OV
SUB A,x	Subtract immediate data from ACC	1	Z,C,AC,OV
SUB A,[m]	Subtract data memory from ACC	1	Z,C,AC,OV
SUBM A,[m]	Subtract data memory from ACC with result in data memory	1 ⁽¹⁾	Z,C,AC,OV
SBC A,[m]	Subtract data memory from ACC with carry	1	Z,C,AC,OV
SBCM A,[m]	Subtract data memory from ACC with carry with result in data memory	1 ⁽¹⁾	Z,C,AC,OV
DAA [m]	Decimal adjust ACC for addition with result in data memory	1 ⁽¹⁾	C
Logic Operation			
AND A,[m]	AND data memory to ACC	1	Z
OR A,[m]	OR data memory to ACC	1	Z
XOR A,[m]	Exclusive-OR data memory to ACC	1	Z
ANDM A,[m]	AND ACC to data memory	1 ⁽¹⁾	Z
ORM A,[m]	OR ACC to data memory	1 ⁽¹⁾	Z
XORM A,[m]	Exclusive-OR ACC to data memory	1 ⁽¹⁾	Z
AND A,x	AND immediate data to ACC	1	Z
OR A,x	OR immediate data to ACC	1	Z
XOR A,x	Exclusive-OR immediate data to ACC	1	Z
CPL [m]	Complement data memory	1 ⁽¹⁾	Z
CPLA [m]	Complement data memory with result in ACC	1	Z
Increment and Decrement			
INCA [m]	Increment data memory with result in ACC	1	Z
INC [m]	Increment data memory	1 ⁽¹⁾	Z
DECA [m]	Decrement data memory with result in ACC	1	Z
DEC [m]	Decrement data memory	1 ⁽¹⁾	Z

Mnemonic	Description	Instruction Cycle	Flag Affected
Rotate			
RRA [m]	Rotate data memory right with result in ACC	1	None
RR [m]	Rotate data memory right	1 ⁽¹⁾	None
RRCA [m]	Rotate data memory right through carry with result in ACC	1	C
RRC [m]	Rotate data memory right through carry	1 ⁽¹⁾	C
RLA [m]	Rotate data memory left with result in ACC	1	None
RL [m]	Rotate data memory left	1 ⁽¹⁾	None
RLCA [m]	Rotate data memory left through carry with result in ACC	1	C
RLC [m]	Rotate data memory left through carry	1 ⁽¹⁾	C
Data Move			
MOV A,[m]	Move data memory to ACC	1	None
MOV [m],A	Move ACC to data memory	1 ⁽¹⁾	None
MOV A,x	Move immediate data to ACC	1	None
Bit Operation			
CLR [m].i	Clear bit of data memory	1 ⁽¹⁾	None
SET [m].i	Set bit of data memory	1 ⁽¹⁾	None
Branch			
JMP addr	Jump unconditional	2	None
SZ [m]	Skip if data memory is zero	1 ⁽²⁾	None
SZA [m]	Skip if data memory is zero with data movement to ACC	1 ⁽²⁾	None
SZ [m].i	Skip if bit i of data memory is zero	1 ⁽²⁾	None
SNZ [m].i	Skip if bit i of data memory is not zero	1 ⁽²⁾	None
SIZ [m]	Skip if increment data memory is zero	1 ⁽³⁾	None
SDZ [m]	Skip if decrement data memory is zero	1 ⁽³⁾	None
SIZA [m]	Skip if increment data memory is zero with result in ACC	1 ⁽²⁾	None
SDZA [m]	Skip if decrement data memory is zero with result in ACC	1 ⁽²⁾	None
CALL addr	Subroutine call	2	None
RET	Return from subroutine	2	None
RET A,x	Return from subroutine and load immediate data to ACC	2	None
RETI	Return from interrupt	2	None
Table Read			
TABRDC [m]	Read ROM code (current page) to data memory and TBLH	2 ⁽¹⁾	None
TABRDL [m]	Read ROM code (last page) to data memory and TBLH	2 ⁽¹⁾	None

Mnemonic	Description	Instruction Cycle	Flag Affected
Miscellaneous			
NOP	No operation	1	None
CLR [m]	Clear data memory	1 ⁽¹⁾	None
SET [m]	Set data memory	1 ⁽¹⁾	None
CLR WDT	Clear Watchdog Timer	1	TO,PD
CLR WDT1	Pre-clear Watchdog Timer	1	TO*,PD*
CLR WDT2	Pre-clear Watchdog Timer	1	TO*,PD*
SWAP [m]	Swap nibbles of data memory	1 ⁽¹⁾	None
SWAPA [m]	Swap nibbles of data memory with result in ACC	1	None
HALT	Enter power down mode	1	TO,PD

Note: x: 8 bits immediate data

m: 8 bits data memory address

A: accumulator

i: 0~7 number of bits

addr: 13 bits program memory address

√ : Flag is affected

– : Flag is not affected

* : Flag may be affected by the execution status

⁽¹⁾: If a loading to the PCL register occurs, the execution cycle of instructions will be delayed one for one more cycles (4 system clocks)

⁽²⁾: If a skip to the next instruction occurs, the execution cycle of instructions will be delayed one more cycle (4 system clocks). Otherwise the original instruction cycle(s) is unchanged.

⁽³⁾: ⁽¹⁾ or ⁽²⁾

Instruction Definition

ADC A,[m] Add data memory and carry to accumulator
 Description The contents of the specified data memory, accumulator and the carry flag are added simultaneously, leaving the result in the accumulator.
 Operation $ACC \leftarrow ACC+[m]+C$
 Affected flag(s)

TC2	TC1	TO	PD	OV	Z	AC	C
—	—	—	—	√	√	√	√

ADCM A,[m] Add accumulator and carry to data memory
 Description The contents of the specified data memory, accumulator and the carry flag are added simultaneously, leaving the result in the specified data memory.
 Operation $[m] \leftarrow ACC+[m]+C$
 Affected flag(s)

TC2	TC1	TO	PD	OV	Z	AC	C
—	—	—	—	√	√	√	√

ADD A,[m] Add data memory to accumulator
 Description The contents of the specified data memory and the accumulator are added. The result is stored in the accumulator.
 Operation $ACC \leftarrow ACC+[m]$
 Affected flag(s)

TC2	TC1	TO	PD	OV	Z	AC	C
—	—	—	—	√	√	√	√

ADD A,x Add immediate data to accumulator
 Description The contents of the accumulator and the specified data are added, leaving the result in the accumulator.
 Operation $ACC \leftarrow ACC+x$
 Affected flag(s)

TC2	TC1	TO	PD	OV	Z	AC	C
—	—	—	—	√	√	√	√

ADDM A,[m] Add accumulator to data memory

Description The contents of the specified data memory and the accumulator are added. The result is stored in the data memory.

Operation $[m] \leftarrow ACC + [m]$

Affected flag(s)

TC2	TC1	TO	PD	OV	Z	AC	C
—	—	—	—	√	√	√	√

AND A,[m] Logical AND accumulator with data memory

Description Data in the accumulator and the specified data memory performs a bitwise logical_AND operation. The result is stored in the accumulator.

Operation $ACC \leftarrow ACC \text{ "AND" } [m]$

Affected flag(s)

TC2	TC1	TO	PD	OV	Z	AC	C
—	—	—	—	—	√	—	—

AND A,x Logical AND immediate data to accumulator

Description Data in the accumulator and the specified data performs a bitwise logical_AND operation. The result is stored in the accumulator.

Operation $ACC \leftarrow ACC \text{ "AND" } x$

Affected flag(s)

TC2	TC1	TO	PD	OV	Z	AC	C
—	—	—	—	—	√	—	—

ANDM A,[m] Logical AND data memory with accumulator

Description Data in the specified data memory and the accumulator performs a bitwise logical_AND operation. The result is stored in the data memory.

Operation $[m] \leftarrow ACC \text{ "AND" } [m]$

Affected flag(s)

TC2	TC1	TO	PD	OV	Z	AC	C
—	—	—	—	—	√	—	—

CALL addr Subroutine call

Description The instruction unconditionally calls a subroutine located at the indicated address. The program counter increments once to obtain the address of the next instruction, and pushes this onto the stack. The indicated address is then loaded. Program execution continues with the instruction at this address.

Operation Stack \leftarrow PC+1
PC \leftarrow addr

Affected flag(s)

TC2	TC1	TO	PD	OV	Z	AC	C
—	—	—	—	—	—	—	—

CLR [m] Clear data memory

Description The contents of the specified data memory are cleared to zero.

Operation [m] \leftarrow 00H

Affected flag(s)

TC2	TC1	TO	PD	OV	Z	AC	C
—	—	—	—	—	—	—	—

CLR [m].i Clear bit of data memory

Description The bit i of the specified data memory is cleared to zero.

Operation [m].i \leftarrow 0

Affected flag(s)

TC2	TC1	TO	PD	OV	Z	AC	C
—	—	—	—	—	—	—	—

CLR WDT Clear Watchdog Timer

Description The WDT and the WDT Prescaler are cleared (re-counting from zero). The power down bit (PD) and time-out bit (TO) are cleared.

Operation WDT and WDT Prescaler \leftarrow 00H
PD and TO \leftarrow 0

Affected flag(s)

TC2	TC1	TO	PD	OV	Z	AC	C
—	—	0	0	—	—	—	—

CLR WDT1

Preclear Watchdog Timer

Description

The PD, TO flags, WDT and the WDT Prescaler are cleared (re-counting from zero), if the other preclear WDT instruction had been executed. Execution of this instruction without the other preclear instruction only sets the indicating flag which implies that this instruction was executed and the PD and TO flags remain unchanged.

Operation

WDT and WDT Prescaler \leftarrow 00H*
 PD and TO \leftarrow 0*

Affected flag(s)

TC2	TC1	TO	PD	OV	Z	AC	C
—	—	0*	0*	—	—	—	—

CLR WDT2

Preclear Watchdog Timer

Description

The PD, TO flags, WDT and the WDT Prescaler are cleared (re-counting from zero), if the other preclear WDT instruction had been executed. Execution of this instruction without the other preclear instruction, only sets the indicating flag which implies that this instruction was executed and the PD and TO flags remain unchanged.

Operation

WDT and WDT Prescaler \leftarrow 00H*
 PD and TO \leftarrow 0*

Affected flag(s)

TC2	TC1	TO	PD	OV	Z	AC	C
—	—	0*	0*	—	—	—	—

CPL [m]

Complement data memory

Description

Each bit of the specified data memory is logically complemented (1's complement). Bits which previously contain a one are changed to zero and vice-versa.

Operation

[m] \leftarrow $\overline{[m]}$

Affected flag(s)

TC2	TC1	TO	PD	OV	Z	AC	C
—	—	—	—	—	√	—	—

CPLA [m] Complement data memory and place result in accumulator

Description Each bit of the specified data memory is logically complemented (1's complement). Bits which previously contained a one are changed to zero and vice-versa. The complemented result is stored in the accumulator and the contents of the data memory remains unchanged.

Operation $ACC \leftarrow [\bar{m}]$

Affected flag(s)

TC2	TC1	TO	PD	OV	Z	AC	C
—	—	—	—	—	√	—	—

DAA [m] Decimal-Adjust accumulator for addition

Description The accumulator value is adjusted to the BCD (Binary Code Decimal) code. The accumulator is divided into two nibbles. Each nibble is adjusted to the BCD code and an internal carry (AC1) will be done if the low nibble of the accumulator is greater than 9. The BCD adjustment is done by adding 6 to the original value if the original value is greater than 9 or a carry (AC or C) is set; otherwise the original value remains unchanged. The result is stored in the data memory and only the carry flag (C) may be affected.

Operation

If $(ACC.3 \sim ACC.0) > 9$ or $AC=1$
then $([m].3 \sim [m].0) \leftarrow (ACC.3 \sim ACC.0) + 6$, $AC1 = \overline{AC}$
else $([m].3 \sim [m].0) \leftarrow (ACC.3 \sim ACC.0)$, $AC1 = 0$
and
If $(ACC.7 \sim ACC.4) + AC1 > 9$ or $C=1$
then $([m].7 \sim [m].4) \leftarrow (ACC.7 \sim ACC.4) + 6 + AC1$, $C=1$
else $([m].7 \sim [m].4) \leftarrow (ACC.7 \sim ACC.4) + AC1$, $C=C$

Affected flag(s)

TC2	TC1	TO	PD	OV	Z	AC	C
—	—	—	—	—	—	—	√

DEC [m] Decrement data memory

Description Data in the specified data memory is decremented by one.

Operation $[m] \leftarrow [m] - 1$

Affected flag(s)

TC2	TC1	TO	PD	OV	Z	AC	C
—	—	—	—	—	√	—	—

DECA [m] Decrement data memory and place result in accumulator
 Description Data in the specified data memory is decremented by one, leaving the result in the accumulator. The contents of the data memory remain unchanged.

Operation $ACC \leftarrow [m]-1$

Affected flag(s)

TC2	TC1	TO	PD	OV	Z	AC	C
—	—	—	—	—	√	—	—

HALT Enter power down mode

Description This instruction stops the program execution and turns off the system clock. The contents of the RAM and registers are retained. The WDT and prescaler are cleared. The power down bit (PD) is set and the WDT time-out bit (TO) is cleared.

Operation $PC \leftarrow PC+1$
 $PD \leftarrow 1$
 $TO \leftarrow 0$

Affected flag(s)

TC2	TC1	TO	PD	OV	Z	AC	C
—	—	0	1	—	—	—	—

INC [m] Increment data memory

Description Data in the specified data memory is incremented by one.

Operation $[m] \leftarrow [m]+1$

Affected flag(s)

TC2	TC1	TO	PD	OV	Z	AC	C
—	—	—	—	—	√	—	—

INCA [m] Increment data memory and place result in accumulator

Description Data in the specified data memory is incremented by one, leaving the result in the accumulator. The contents of the data memory remain unchanged.

Operation $ACC \leftarrow [m]+1$

Affected flag(s)

TC2	TC1	TO	PD	OV	Z	AC	C
—	—	—	—	—	√	—	—

JMP addr Direct Jump
 Description Bits 0~12 of the program counter are replaced with the directly-specified address unconditionally, and control is passed to this destination.
 Operation $PC \leftarrow \text{addr}$
 Affected flag(s)

TC2	TC1	TO	PD	OV	Z	AC	C
—	—	—	—	—	—	—	—

MOV A,[m] Move data memory to accumulator
 Description The contents of the specified data memory is copied to the accumulator.
 Operation $ACC \leftarrow [m]$
 Affected flag(s)

TC2	TC1	TO	PD	OV	Z	AC	C
—	—	—	—	—	—	—	—

MOV A,x Move immediate data to accumulator
 Description The 8-bit data specified by the code is loaded into the accumulator.
 Operation $ACC \leftarrow x$
 Affected flag(s)

TC2	TC1	TO	PD	OV	Z	AC	C
—	—	—	—	—	—	—	—

MOV [m],A Move accumulator to data memory
 Description The contents of the accumulator is copied to the specified data memory (one of the data memory).
 Operation $[m] \leftarrow ACC$
 Affected flag(s)

TC2	TC1	TO	PD	OV	Z	AC	C
—	—	—	—	—	—	—	—

NOP No operation
 Description No operation is performed. Execution continues with the next instruction.
 Operation $PC \leftarrow PC+1$
 Affected flag(s)

TC2	TC1	TO	PD	OV	Z	AC	C
—	—	—	—	—	—	—	—

OR A,[m] Logical OR accumulator with data memory
 Description Data in the accumulator and the specified data memory (one of the data memories) performs a bitwise logical_OR operation. The result is stored in the accumulator.
 Operation $ACC \leftarrow ACC \text{ "OR" } [m]$
 Affected flag(s)

TC2	TC1	TO	PD	OV	Z	AC	C
—	—	—	—	—	√	—	—

OR A,x Logical OR immediate data to accumulator
 Description Data in the accumulator and the specified data performs a bitwise logical_OR operation. The result is stored in the accumulator.
 Operation $ACC \leftarrow ACC \text{ "OR" } x$
 Affected flag(s)

TC2	TC1	TO	PD	OV	Z	AC	C
—	—	—	—	—	√	—	—

ORM A,[m] Logical OR data memory with accumulator
 Description Data in the data memory (one of the data memories) and the accumulator performs a bitwise logical_OR operation. The result is stored in the data memory.
 Operation $[m] \leftarrow ACC \text{ "OR" } [m]$
 Affected flag(s)

TC2	TC1	TO	PD	OV	Z	AC	C
—	—	—	—	—	√	—	—

RET Return from subroutine
 Description The program counter is restored from the stack. This is a two-cycle instruction.
 Operation $PC \leftarrow \text{Stack}$
 Affected flag(s)

TC2	TC1	TO	PD	OV	Z	AC	C
—	—	—	—	—	—	—	—

RET A,x Return and place immediate data in accumulator
 Description The program counter is restored from the stack and the accumulator loaded with the specified 8-bit immediate data.
 Operation $PC \leftarrow \text{Stack}$
 $ACC \leftarrow x$
 Affected flag(s)

TC2	TC1	TO	PD	OV	Z	AC	C
—	—	—	—	—	—	—	—

RETI Return from interrupt
 Description The program counter is restored from the stack, and interrupts are enabled by setting the EMI bit. EMI is the enable master (global) interrupt bit (bit 0; register INTC).
 Operation $PC \leftarrow \text{Stack}$
 $EMI \leftarrow 1$
 Affected flag(s)

TC2	TC1	TO	PD	OV	Z	AC	C
—	—	—	—	—	—	—	—

RL [m] Rotate data memory left
 Description The contents of the specified data memory is rotated one bit left, with bit 7 rotated into bit 0.
 Operation $[m].(i+1) \leftarrow [m].i$; $[m].i$: bit i of the data memory ($i=0-6$)
 $[m].0 \leftarrow [m].7$
 Affected flag(s)

TC2	TC1	TO	PD	OV	Z	AC	C
—	—	—	—	—	—	—	—

RLA [m] Rotate data memory left and place result in accumulator

Description Data in the specified data memory is rotated one bit left, with bit 7 rotated into bit 0, leaving the rotated result in the accumulator. The contents of the data memory remain unchanged.

Operation $ACC.(i+1) \leftarrow [m].i$; $[m].i$:bit i of the data memory (i=0-6)
 $ACC.0 \leftarrow [m].7$

Affected flag(s)

TC2	TC1	TO	PD	OV	Z	AC	C
—	—	—	—	—	—	—	—

RLC [m] Rotate data memory left through carry

Description The contents of the specified data memory and the carry flag are together rotated one bit left. Bit 7 replaces the carry bit; the original carry flag is rotated into the bit 0 position.

Operation $[m].(i+1) \leftarrow [m].i$; $[m].i$:bit i of the data memory (i=0-6)
 $[m].0 \leftarrow C$
 $C \leftarrow [m].7$

Affected flag(s)

TC2	TC1	TO	PD	OV	Z	AC	C
—	—	—	—	—	—	—	√

RLCA [m] Rotate left through carry and place result in accumulator

Description Data in the specified data memory and the carry flag are together rotated one bit left. Bit 7 replaces the carry bit and the original carry flag is rotated into bit 0 position. The rotated result is stored in the accumulator but the contents of the data memory remain unchanged.

Operation $ACC.(i+1) \leftarrow [m].i$; $[m].i$:bit i of the data memory (i=0-6)
 $ACC.0 \leftarrow C$
 $C \leftarrow [m].7$

Affected flag(s)

TC2	TC1	TO	PD	OV	Z	AC	C
—	—	—	—	—	—	—	√

RR [m] Rotate data memory right

Description The contents of the specified data memory are rotated one bit right with bit 0 rotated to bit 7.

Operation $[m].i \leftarrow [m].(i+1)$; $[m].i$:bit i of the data memory ($i=0-6$)
 $[m].7 \leftarrow [m].0$

Affected flag(s)

TC2	TC1	TO	PD	OV	Z	AC	C
—	—	—	—	—	—	—	—

RRA [m] Rotate right and place result in accumulator

Description Data in the specified data memory is rotated one bit right with bit 0 rotated into bit 7, leaving the rotated result in the accumulator. The contents of the data memory remain unchanged.

Operation $ACC.(i) \leftarrow [m].(i+1)$; $[m].i$:bit i of the data memory ($i=0-6$)
 $ACC.7 \leftarrow [m].0$

Affected flag(s)

TC2	TC1	TO	PD	OV	Z	AC	C
—	—	—	—	—	—	—	—

RRC [m] Rotate data memory right through carry

Description The contents of the specified data memory and the carry flag are together rotated one bit right. Bit 0 replaces the carry bit; the original carry flag is rotated into the bit 7 position.

Operation $[m].i \leftarrow [m].(i+1)$; $[m].i$:bit i of the data memory ($i=0-6$)
 $[m].7 \leftarrow C$
 $C \leftarrow [m].0$

Affected flag(s)

TC2	TC1	TO	PD	OV	Z	AC	C
—	—	—	—	—	—	—	√

RRCA [m] Rotate right through carry and place result in accumulator

Description Data of the specified data memory and the carry flag are together rotated one bit right. Bit 0 replaces the carry bit and the original carry flag is rotated into the bit 7 position. The rotated result is stored in the accumulator. The contents of the data memory remain unchanged.

Operation $ACC.i \leftarrow [m].(i+1)$; $[m].i$:bit i of the data memory (i=0-6)
 $ACC.7 \leftarrow C$
 $C \leftarrow [m].0$

Affected flag(s)

TC2	TC1	TO	PD	OV	Z	AC	C
—	—	—	—	—	—	—	√

SBC A,[m] Subtract data memory and carry from accumulator

Description The contents of the specified data memory and the complement of the carry flag are together subtracted from the accumulator, leaving the result in the accumulator.

Operation $ACC \leftarrow ACC + [\bar{m}] + C$

Affected flag(s)

TC2	TC1	TO	PD	OV	Z	AC	C
—	—	—	—	√	√	√	√

SBCM A,[m] Subtract data memory and carry from accumulator

Description The contents of the specified data memory and the complement of the carry flag are together subtracted from the accumulator, leaving the result in the data memory.

Operation $[m] \leftarrow ACC + [\bar{m}] + C$

Affected flag(s)

TC2	TC1	TO	PD	OV	Z	AC	C
—	—	—	—	√	√	√	√

SDZ [m] Skip if decrement data memory is zero

Description The contents of the specified data memory are decremented by one. If the result is zero, the next instruction is skipped. If the result is zero, the following instruction, fetched during the current instruction execution, is discarded and a dummy cycle is replaced to get the proper instruction. This makes a two-cycle instruction. Otherwise proceed with the next instruction.

Operation Skip if $([m]-1)=0$, $[m] \leftarrow ([m]-1)$

Affected flag(s)

TC2	TC1	TO	PD	OV	Z	AC	C
—	—	—	—	—	—	—	—

SDZA [m] Decrement data memory and place result in ACC, skip if zero

Description The contents of the specified data memory are decremented by one. If the result is zero, the next instruction is skipped. The result is stored in the accumulator but the data memory remains unchanged. If the result is zero, the following instruction, fetched during the current instruction execution, is discarded and a dummy cycle is replaced to get the proper instruction, that makes a two-cycle instruction. Otherwise proceed with the next instruction.

Operation Skip if $([m]-1)=0$, $ACC \leftarrow ([m]-1)$

Affected flag(s)

TC2	TC1	TO	PD	OV	Z	AC	C
—	—	—	—	—	—	—	—

SET [m] Set data memory

Description Each bit of the specified data memory is set to one.

Operation $[m] \leftarrow FFH$

Affected flag(s)

TC2	TC1	TO	PD	OV	Z	AC	C
—	—	—	—	—	—	—	—

SET [m].i Set bit of data memory
 Description Bit i of the specified data memory is set to one.
 Operation $[m].i \leftarrow 1$
 Affected flag(s)

TC2	TC1	TO	PD	OV	Z	AC	C
—	—	—	—	—	—	—	—

SIZ [m] Skip if increment data memory is zero
 Description The contents of the specified data memory is incremented by one. If the result is zero, the following instruction, fetched during the current instruction execution, is discarded and a dummy cycle is replaced to get the proper instruction. This is a two-cycle instruction. Otherwise proceed with the next instruction.
 Operation Skip if $([m]+1)=0$, $[m] \leftarrow ([m]+1)$
 Affected flag(s)

TC2	TC1	TO	PD	OV	Z	AC	C
—	—	—	—	—	—	—	—

SIZA [m] Increment data memory and place result in ACC, skip if zero
 Description The contents of the specified data memory is incremented by one. If the result is zero, the next instruction is skipped and the result is stored in the accumulator. The data memory remains unchanged. If the result is zero, the following instruction, fetched during the current instruction execution, is discarded and a dummy cycle is replaced to get the proper instruction. This is a two-cycle instruction. Otherwise proceed with the next instruction.
 Operation Skip if $([m]+1)=0$, $ACC \leftarrow ([m]+1)$
 Affected flag(s)

TC2	TC1	TO	PD	OV	Z	AC	C
—	—	—	—	—	—	—	—

SNZ [m].i

Description

Skip if bit i of the data memory is not zero

If bit i of the specified data memory is not zero, the next instruction is skipped. If bit i of the data memory is not zero, the following instruction, fetched during the current instruction execution, is discarded and a dummy cycle is replaced to get the proper instruction. This is a two-cycle instruction. Otherwise proceed with the next instruction.

Operation

Skip if [m].i≠0

Affected flag(s)

TC2	TC1	TO	PD	OV	Z	AC	C
—	—	—	—	—	—	—	—

SUB A,[m]

Description

Subtract data memory from accumulator

The specified data memory is subtracted from the contents of the accumulator, leaving the result in the accumulator.

Operation

$ACC \leftarrow ACC + \overline{[m]} + 1$

Affected flag(s)

TC2	TC1	TO	PD	OV	Z	AC	C
—	—	—	—	√	√	√	√

SUBM A,[m]

Description

Subtract data memory from accumulator

The specified data memory is subtracted from the contents of the accumulator, leaving the result in the data memory.

Operation

$[m] \leftarrow ACC \overline{[m]} + 1$

Affected flag(s)

TC2	TC1	TO	PD	OV	Z	AC	C
—	—	—	—	√	√	√	√

SUB A,x

Description

Subtract immediate data from accumulator

The immediate data specified by the code is subtracted from the contents of the accumulator, leaving the result in the accumulator.

Operation

$ACC \leftarrow ACC + \overline{x} + 1$

Affected flag(s)

TC2	TC1	TO	PD	OV	Z	AC	C
—	—	—	—	√	√	√	√

SWAP [m] Swap nibbles within the data memory

Description The low-order and high-order nibbles of the specified data memory (one of the data memories) are interchanged.

Operation $[m].3\sim[m].0 \leftrightarrow [m].7\sim[m].4$

Affected flag(s)

TC2	TC1	TO	PD	OV	Z	AC	C
—	—	—	—	—	—	—	—

SWAPA [m] Swap data memory and place result in accumulator

Description The low-order and high-order nibbles of the specified data memory are interchanged, writing the result to the accumulator. The contents of the data memory remain unchanged.

Operation $ACC.3\sim ACC.0 \leftarrow [m].7\sim[m].4$
 $ACC.7\sim ACC.4 \leftarrow [m].3\sim[m].0$

Affected flag(s)

TC2	TC1	TO	PD	OV	Z	AC	C
—	—	—	—	—	—	—	—

SZ [m] Skip if data memory is zero

Description If the contents of the specified data memory is zero, the following instruction, fetched during the current instruction execution, is discarded and a dummy cycle is replaced to get the proper instruction. This is a two-cycle instruction. Otherwise proceed with the next instruction.

Operation Skip if $[m]=0$

Affected flag(s)

TC2	TC1	TO	PD	OV	Z	AC	C
—	—	—	—	—	—	—	—

SZA [m] Move data memory to ACC, skip if zero

Description The contents of the specified data memory is copied to the accumulator. If the contents is zero, the following instruction, fetched during the current instruction execution, is discarded and a dummy cycle is replaced to get the proper instruction. This is a two-cycle instruction. Otherwise proceed with the next instruction.

Operation Skip if [m]=0

Affected flag(s)

TC2	TC1	TO	PD	OV	Z	AC	C
—	—	—	—	—	—	—	—

SZ [m].i Skip if bit i of the data memory is zero

Description If bit i of the specified data memory is zero, the following instruction, fetched during the current instruction execution, is discarded and a dummy cycle is replaced to get the proper instruction. This is a two-cycle instruction. Otherwise proceed with the next instruction.

Operation Skip if [m].i=0

Affected flag(s)

TC2	TC1	TO	PD	OV	Z	AC	C
—	—	—	—	—	—	—	—

TABRDC [m] Move ROM code (current page) to TBLH and data memory

Description The ROM code low byte (current page) addressed by the table pointer (TBLP), (TBHP) is moved to the specified data memory and the high byte transferred to TBLH directly.

Operation [m] ← ROM code (low byte)
 TBLH ← ROM code (high byte)

Affected flag(s)

TC2	TC1	TO	PD	OV	Z	AC	C
—	—	—	—	—	—	—	—

TABRDL [m] Move the ROM code (last page) to TBLH and data memory

Description The ROM code low byte (last page) addressed by the table pointer (TBLP) is moved to the data memory and the high byte transferred to TBLH directly.

Operation $[m] \leftarrow$ ROM code (low byte)
 $TBLH \leftarrow$ ROM code (high byte)

Affected flag(s)

TC2	TC1	TO	PD	OV	Z	AC	C
—	—	—	—	—	—	—	—

XOR A,[m] Logical XOR accumulator with data memory

Description Data in the accumulator and the indicated data memory performs a bitwise logical Exclusive_OR operation and the result is stored in the accumulator.

Operation $ACC \leftarrow ACC \text{ "XOR" } [m]$

Affected flag(s)

TC2	TC1	TO	PD	OV	Z	AC	C
—	—	—	—	—	√	—	—

XORM A,[m] Logical XOR data memory with accumulator

Description Data in the indicated data memory and the accumulator perform a bitwise logical Exclusive_OR operation. The result is stored in the data memory. The zero flag is affected.

Operation $[m] \leftarrow ACC \text{ "XOR" } [m]$

Affected flag(s)

TC2	TC1	TO	PD	OV	Z	AC	C
—	—	—	—	—	√	—	—

XOR A,x Logical XOR immediate data to accumulator

Description Data in the the accumulator and the specified data perform a bitwise logical Exclusive_OR operation. The result is stored in the accumulator. The zero flag is affected.

Operation $ACC \leftarrow ACC \text{ "XOR" } x$

Affected flag(s)

TC2	TC1	TO	PD	OV	Z	AC	C
—	—	—	—	—	√	—	—

Holtek Semiconductor Inc. (Headquarters)

No.3 Creation Rd. II, Science-based Industrial Park, Hsinchu, Taiwan, R.O.C.
Tel: 886-3-563-1999
Fax: 886-3-563-1189

Holtek Semiconductor Inc. (Taipei Office)

5F, No.576, Sec.7 Chung Hsiao E. Rd., Taipei, Taiwan, R.O.C.
Tel: 886-2-2782-9635
Fax: 886-2-2782-9636
Fax: 886-2-2782-7128 (International sales hotline)

Holtek Semiconductor (Hong Kong) Ltd.

RM.711, Tower 2, Cheung Sha Wan Plaza, 833 Cheung Sha Wan Rd., Kowloon, Hong Kong
Tel: 852-2-745-8288
Fax: 852-2-742-8657

Copyright © 2000 by HOLTEK SEMICONDUCTOR INC.

The information appearing in this Data Sheet is believed to be accurate at the time of publication. However, Holtek assumes no responsibility arising from the use of the specifications described. The applications mentioned herein are used solely for the purpose of illustration and Holtek makes no warranty or representation that such applications will be suitable without further modification, nor recommends the use of its products for application that may present a risk to human life due to malfunction or otherwise. Holtek reserves the right to alter its products without prior notification. For the most up-to-date information, please visit our web site at <http://www.holtek.com.tw>.