

**6A, 80V, 0.030 Ohm, N-Channel,
UltraFET Power MOSFET**

Packaging

JEDEC MS-012AA

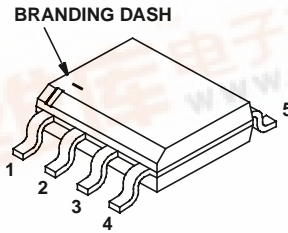

Features

- Ultra Low On-Resistance
 - $r_{DS(ON)} = 0.030\Omega, V_{GS} = 10V$
- Simulation Models
 - Temperature Compensated PSPICETM and SABER[®] Electrical Models
 - Spice and SABER[®] Thermal Impedance Models
 - www.intersil.com
- Peak Current vs Pulse Width Curve
- UIS Rating Curve

Symbol



Ordering Information

PART NUMBER	PACKAGE	BRAND
HUF75531SK8	MS-012AA	75531SK8

NOTE: When ordering, use the entire part number. Add the suffix T to obtain the variant in tape and reel, e.g., HUF75531SK8T.

Absolute Maximum Ratings $T_A = 25^\circ C$, Unless Otherwise Specified

	HUF75531SK8	UNITS
Drain to Source Voltage (Note 1)	V_{DSS}	80 V
Drain to Gate Voltage ($R_{GS} = 20k\Omega$) (Note 1)	V_{DGR}	80 V
Gate to Source Voltage	V_{GS}	± 20 V
Drain Current		
Continuous ($T_A = 25^\circ C, V_{GS} = 10V$) (Figure 2)	I_D	6 A
Continuous ($T_A = 100^\circ C, V_{GS} = 10V$) (Figure 2)	I_D	4 A
Pulsed Drain Current	I_{DM}	Figure 4
Pulsed Avalanche Rating	UIS	Figures 6, 14, 15
Power Dissipation	P_D	2.5 W
Derate Above $25^\circ C$		20 mW/ $^\circ C$
Operating and Storage Temperature	T_J, T_{STG}	-55 to 150 $^\circ C$
Maximum Temperature for Soldering		
Leads at 0.063in (1.6mm) from Case for 10s	T_L	300 $^\circ C$
Package Body for 10s, See Techbrief TB370	T_{pkg}	260 $^\circ C$

NOTES:

1. $T_J = 25^\circ C$ to $125^\circ C$.
2. $50^\circ C/W$ measured using FR-4 board with 0.76 in^2 (490.3 mm^2) copper pad at 10 second.
3. $152^\circ C/W$ measured using FR-4 board with 0.054 in^2 (34.8 mm^2) copper pad at 1000 seconds
4. $189^\circ C/W$ measured using FR-4 board with 0.0115 in^2 (7.42 mm^2) copper pad at 1000 seconds

CAUTION: Stresses above those listed in "Absolute Maximum Ratings" may cause permanent damage to the device. This is a stress only rating and operation of the device at these or any other conditions above those indicated in the operational sections of this specification is not implied.



HUF75531SK8

Electrical Specifications $T_A = 25^\circ\text{C}$, Unless Otherwise Specified

PARAMETER	SYMBOL	TEST CONDITIONS	MIN	TYP	MAX	UNITS	
OFF STATE SPECIFICATIONS							
Drain to Source Breakdown Voltage	BV_{DSS}	$I_D = 250\mu\text{A}$, $V_{GS} = 0\text{V}$ (Figure 11)	80	-	-	V	
Zero Gate Voltage Drain Current	I_{DSS}	$V_{DS} = 75\text{V}$, $V_{GS} = 0\text{V}$	-	-	1	μA	
		$V_{DS} = 70\text{V}$, $V_{GS} = 0\text{V}$, $T_A = 150^\circ\text{C}$	-	-	250	μA	
Gate to Source Leakage Current	I_{GSS}	$V_{GS} = \pm 20\text{V}$	-	-	± 100	nA	
ON STATE SPECIFICATIONS							
Gate to Source Threshold Voltage	$V_{GS(TH)}$	$V_{GS} = V_{DS}$, $I_D = 250\mu\text{A}$ (Figure 10)	2	-	4	V	
Drain to Source On Resistance	$r_{DS(ON)}$	$I_D = 6\text{A}$, $V_{GS} = 10\text{V}$ (Figure 9)	-	0.025	0.030	Ω	
THERMAL SPECIFICATIONS							
Thermal Resistance Junction to Ambient	$R_{\theta JA}$	Pad Area = 0.76 in^2 (490.3 mm^2) (Note 2)	-	-	50	$^\circ\text{C/W}$	
		Pad Area = 0.054 in^2 (34.8 mm^2) (Note 3)	-	-	152	$^\circ\text{C/W}$	
		Pad Area = 0.0115 in^2 (7.42 mm^2) (Note 4)	-	-	189	$^\circ\text{C/W}$	
SWITCHING SPECIFICATIONS ($V_{GS} = 10\text{V}$)							
Turn-On Time	t_{ON}	$V_{DD} = 40\text{V}$, $I_D = 6\text{A}$ $V_{GS} = 10\text{V}$, $R_{GS} = 6.8\Omega$ (Figures 18, 19)	-	-	55	ns	
Turn-On Delay Time	$t_{d(ON)}$		-	10.5	-	ns	
Rise Time	t_r		-	25	-	ns	
Turn-Off Delay Time	$t_{d(OFF)}$		-	49	-	ns	
Fall Time	t_f		-	29	-	ns	
Turn-Off Time	t_{OFF}		-	-	115	ns	
GATE CHARGE SPECIFICATIONS							
Total Gate Charge	$Q_{g(TOT)}$	$V_{GS} = 0\text{V}$ to 20V	$V_{DD} = 40\text{V}$, $I_D = 6\text{A}$, $I_{g(REF)} = 1.0\text{mA}$ (Figures 13, 16, 17)	-	68	82	nC
Gate Charge at 10V	$Q_{g(10)}$	$V_{GS} = 0\text{V}$ to 10V		-	37	45	nC
Threshold Gate Charge	$Q_{g(TH)}$	$V_{GS} = 0\text{V}$ to 2V		-	2.4	2.9	nC
Gate to Source Gate Charge	Q_{gs}			-	4.8	-	nC
Gate to Drain "Miller" Charge	Q_{gd}			-	14	-	nC
CAPACITANCE SPECIFICATIONS							
Input Capacitance	C_{ISS}	$V_{DS} = 25\text{V}$, $V_{GS} = 0\text{V}$, $f = 1\text{MHz}$ (Figure 12)	-	1210	-	pF	
Output Capacitance	C_{OSS}		-	385	-	pF	
Reverse Transfer Capacitance	C_{RSS}		-	115	-	pF	

Source to Drain Diode Specifications

PARAMETER	SYMBOL	TEST CONDITIONS	MIN	TYP	MAX	UNITS
Source to Drain Diode Voltage	V_{SD}	$I_{SD} = 6\text{A}$	-	-	1.25	V
		$I_{SD} = 4\text{A}$	-	-	1.00	V
Reverse Recovery Time	t_{rr}	$I_{SD} = 6\text{A}$, $di_{SD}/dt = 100\text{A}/\mu\text{s}$	-	-	105	ns
Reverse Recovered Charge	Q_{RR}	$I_{SD} = 6\text{A}$, $di_{SD}/dt = 100\text{A}/\mu\text{s}$	-	-	325	nC

HUF75531SK8

Typical Performance Curves

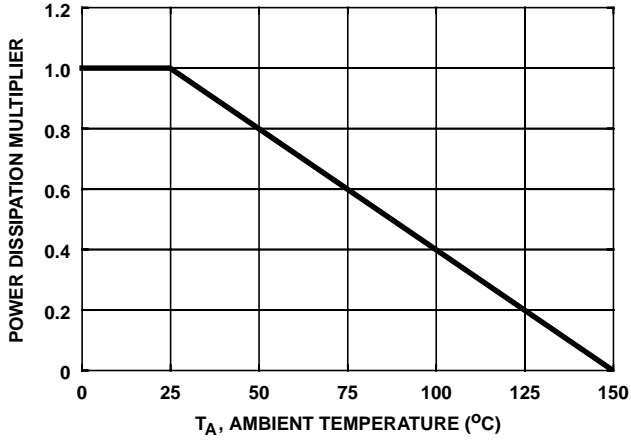

FIGURE 1. NORMALIZED POWER DISSIPATION vs CASE TEMPERATURE

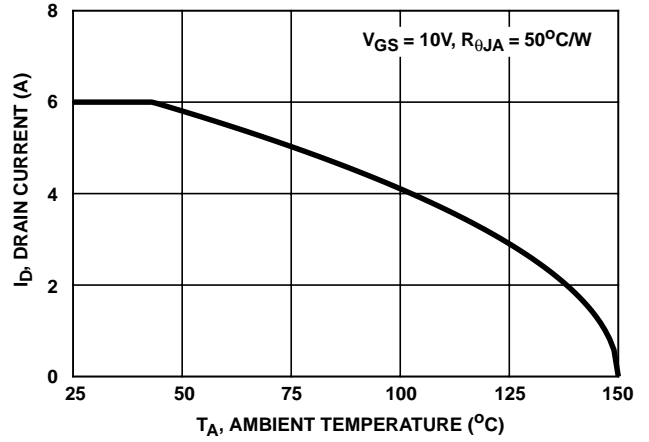

FIGURE 2. MAXIMUM CONTINUOUS DRAIN CURRENT vs CASE TEMPERATURE

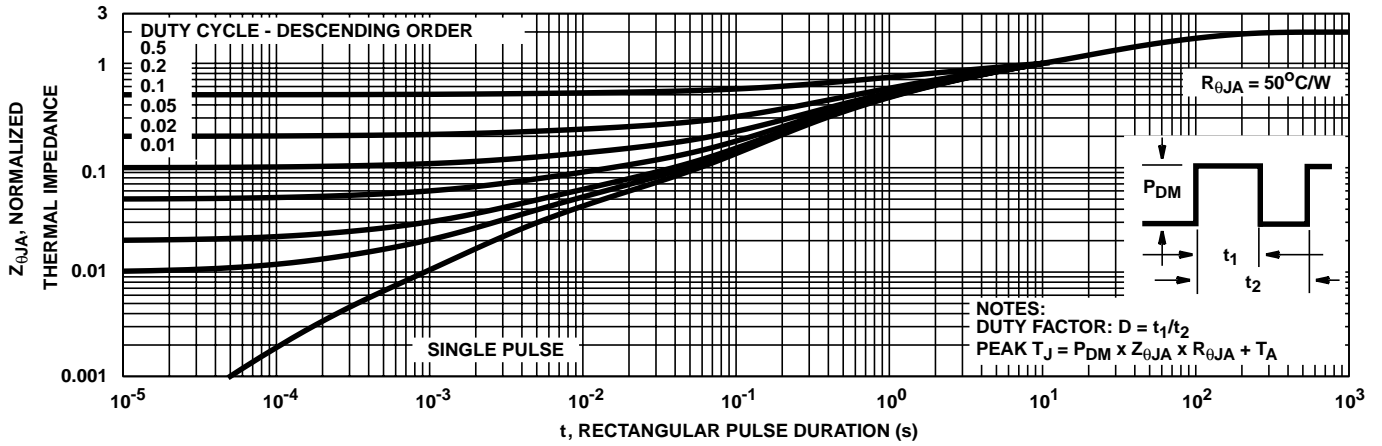

FIGURE 3. NORMALIZED MAXIMUM TRANSIENT THERMAL IMPEDANCE

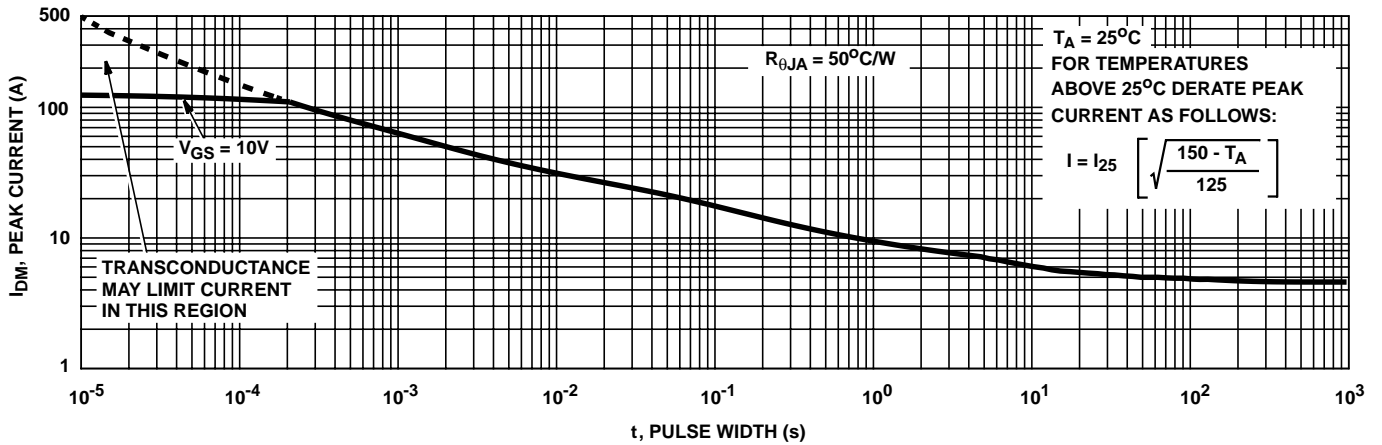

FIGURE 4. PEAK CURRENT CAPABILITY

Typical Performance Curves (Continued)

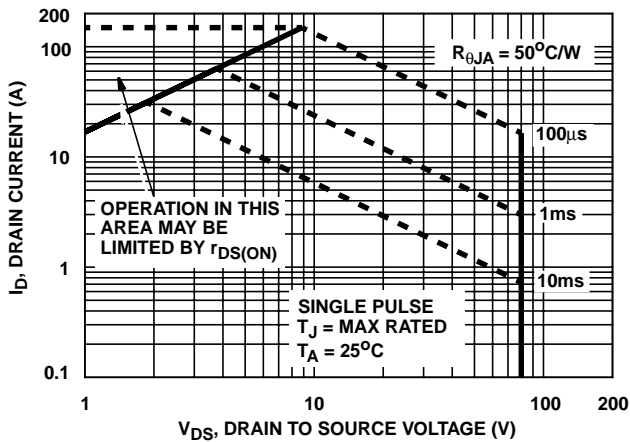
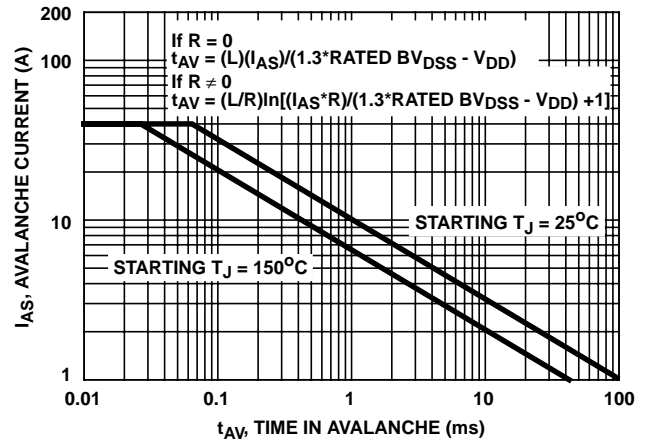

FIGURE 5. FORWARD BIAS SAFE OPERATING AREA



NOTE: Refer to Intersil Application Notes AN9321 and AN9322.

FIGURE 6. UNCLAMPED INDUCTIVE SWITCHING CAPABILITY

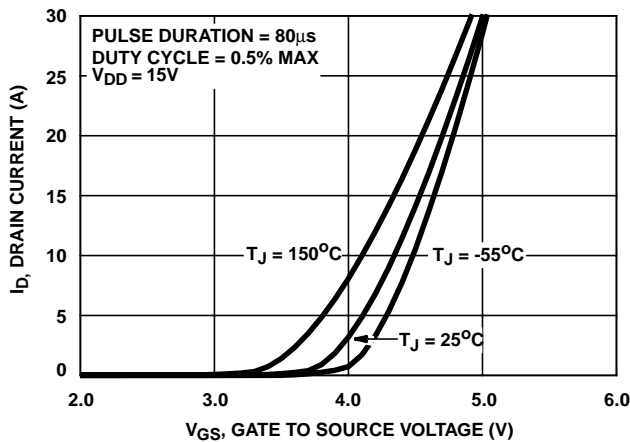

FIGURE 7. TRANSFER CHARACTERISTICS

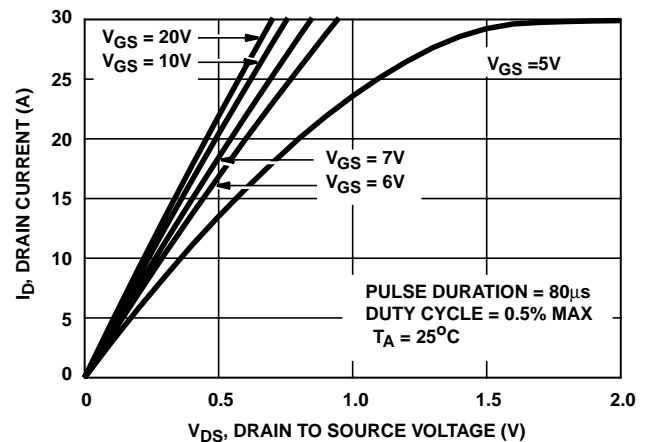

FIGURE 8. SATURATION CHARACTERISTICS

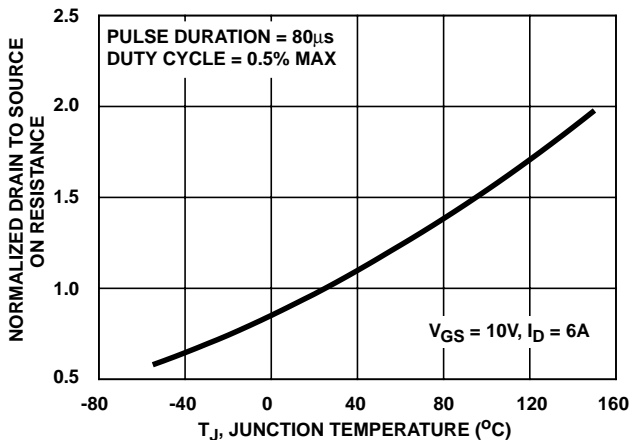

FIGURE 9. NORMALIZED DRAIN TO SOURCE ON RESISTANCE vs JUNCTION TEMPERATURE

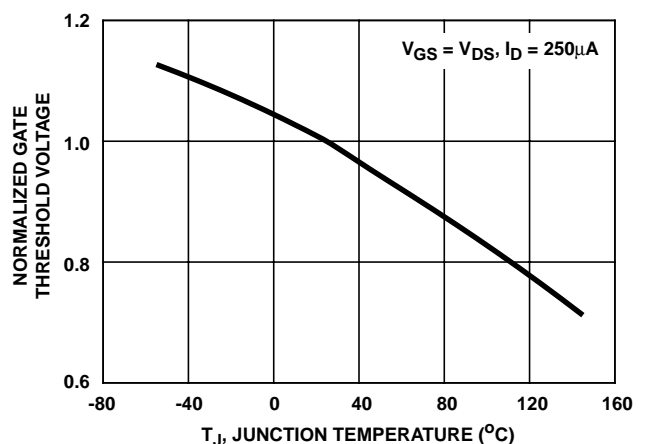

FIGURE 10. NORMALIZED GATE THRESHOLD VOLTAGE vs JUNCTION TEMPERATURE

Typical Performance Curves (Continued)

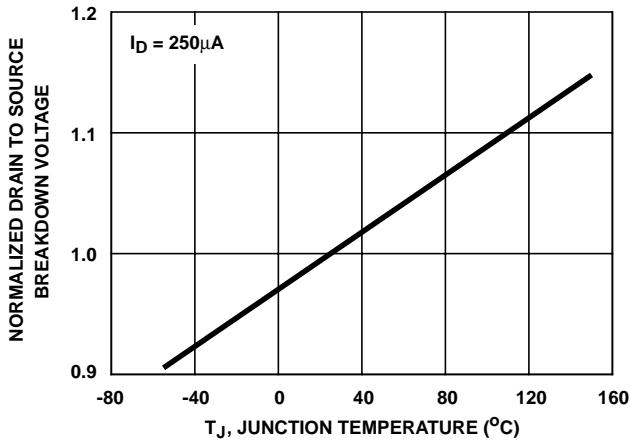

FIGURE 11. NORMALIZED DRAIN TO SOURCE BREAKDOWN VOLTAGE vs JUNCTION TEMPERATURE

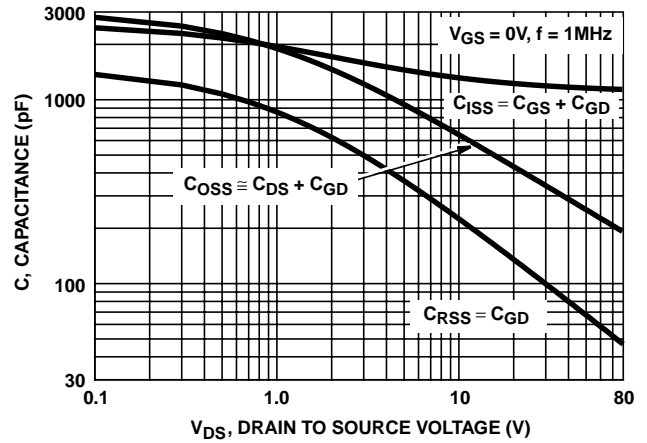
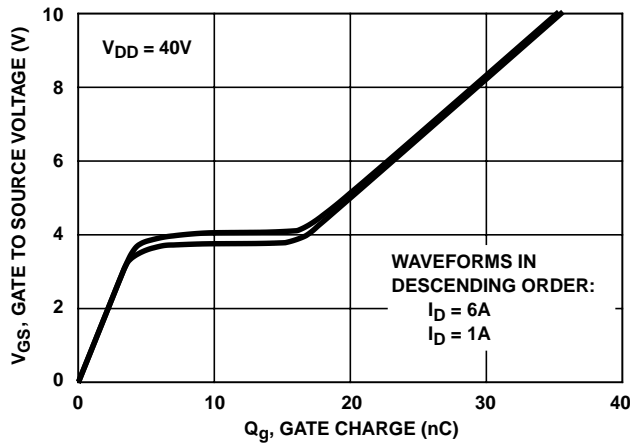

FIGURE 12. CAPACITANCE vs DRAIN TO SOURCE VOLTAGE



NOTE: Refer to Intersil Application Notes AN7254 and AN7260.
 FIGURE 13. GATE CHARGE WAVEFORMS FOR CONSTANT GATE CURRENT

Test Circuits and Waveforms

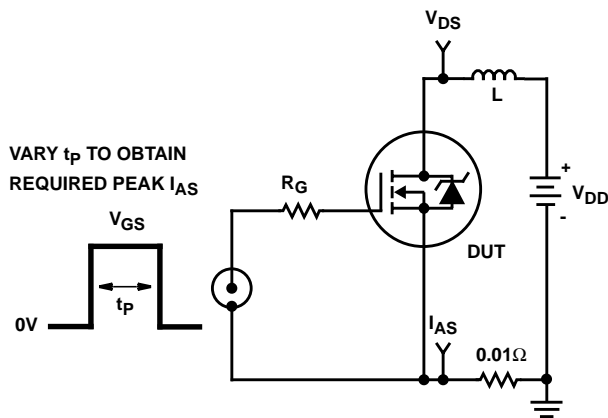

FIGURE 14. UNCLAMPED ENERGY TEST CIRCUIT

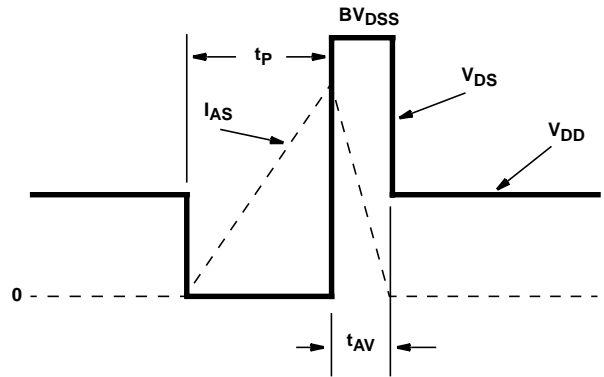

FIGURE 15. UNCLAMPED ENERGY WAVEFORMS

Test Circuits and Waveforms (Continued)

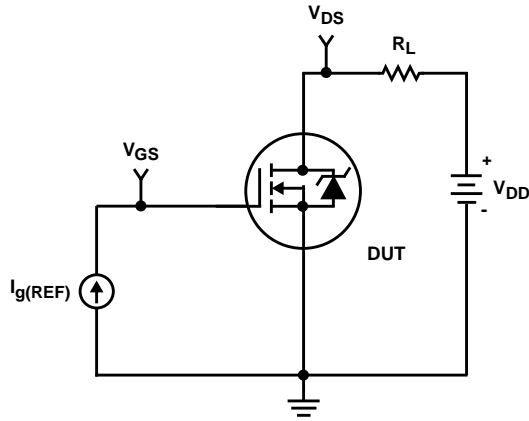

FIGURE 16. GATE CHARGE TEST CIRCUIT

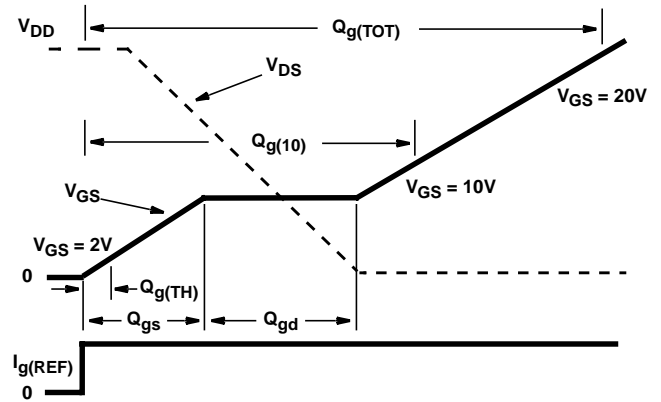

FIGURE 17. GATE CHARGE WAVEFORMS

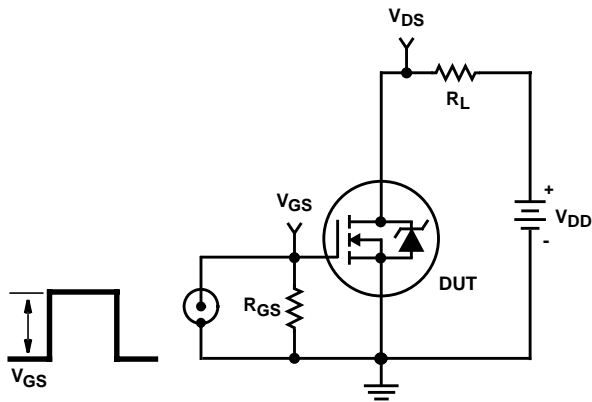

FIGURE 18. SWITCHING TIME TEST CIRCUIT

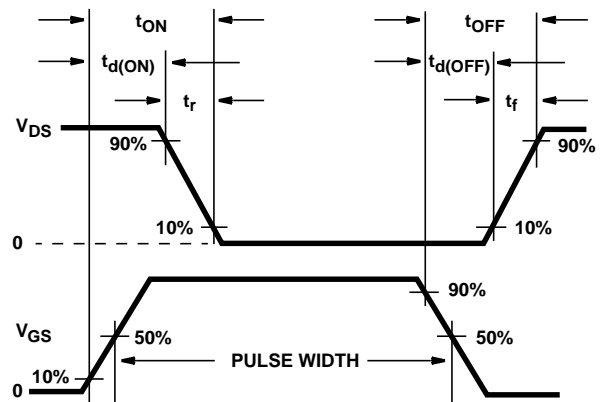

FIGURE 19. SWITCHING TIME WAVEFORM

Thermal Resistance vs. Mounting Pad Area

The maximum rated junction temperature, T_{JM} , and the thermal resistance of the heat dissipating path determines the maximum allowable device power dissipation, P_{DM} , in an application. Therefore the application's ambient temperature, T_A ($^{\circ}C$), and thermal resistance $R_{\theta JA}$ ($^{\circ}C/W$) must be reviewed to ensure that T_{JM} is never exceeded. Equation 1 mathematically represents the relationship and serves as the basis for establishing the rating of the part.

$$P_{DM} = \frac{(T_{JM} - T_A)}{Z_{\theta JA}} \quad (EQ. 1)$$

In using surface mount devices such as the SOP-8 package, the environment in which it is applied will have a significant influence on the part's current and maximum power

dissipation ratings. Precise determination of P_{DM} is complex and influenced by many factors:

1. Mounting pad area onto which the device is attached and whether there is copper on one side or both sides of the board.
2. The number of copper layers and the thickness of the board.
3. The use of external heat sinks.
4. The use of thermal vias.
5. Air flow and board orientation.
6. For non steady state applications, the pulse width, the duty cycle and the transient thermal response of the part, the board and the environment they are in.

Intersil provides thermal information to assist the designer's preliminary application evaluation. Figure 20 defines the

HUF75531SK8

$R_{\theta JA}$ for the device as a function of the top copper (component side) area. This is for a horizontally positioned FR-4 board with 1oz copper after 1000 seconds of steady state power with no air flow. This graph provides the necessary information for calculation of the steady state junction temperature or power dissipation. Pulse applications can be evaluated using the Intersil device Spice thermal model or manually utilizing the normalized maximum transient thermal impedance curve.

Displayed on the curve are $R_{\theta JA}$ values listed in the Electrical Specifications table. The points were chosen to depict the compromise between the copper board area, the thermal resistance and ultimately the power dissipation, P_{DM} .

Thermal resistances corresponding to other copper areas can be obtained from Figure 20 or by calculation using Equation 2. $R_{\theta JA}$ is defined as the natural log of the area times a coefficient added to a constant. The area, in square inches is the top copper area including the gate and source pads.

$$R_{\theta JA} = 83.2 - 23.6 \times \ln(\text{Area}) \quad (\text{EQ. 2})$$

The transient thermal impedance ($Z_{\theta JA}$) is also effected by varied top copper board area. Figure 21 shows the effect of copper pad area on single pulse transient thermal impedance. Each trace represents a copper pad area in square inches corresponding to the descending list in the

graph. Spice and SABER thermal models are provided for each of the listed pad areas.

Copper pad area has no perceivable effect on transient thermal impedance for pulse widths less than 100ms. For pulse widths less than 100ms the transient thermal impedance is determined by the die and package. Therefore, C THERM1 through C THERM5 and R THERM1 through R THERM5 remain constant for each of the thermal models. A listing of the model component values is available in Table 1.

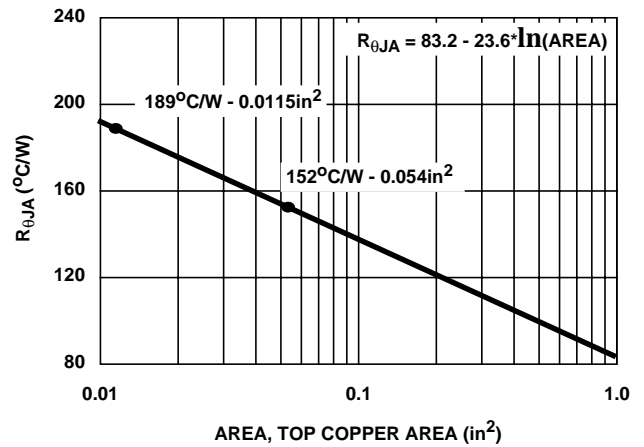

FIGURE 20. THERMAL RESISTANCE vs MOUNTING PAD AREA

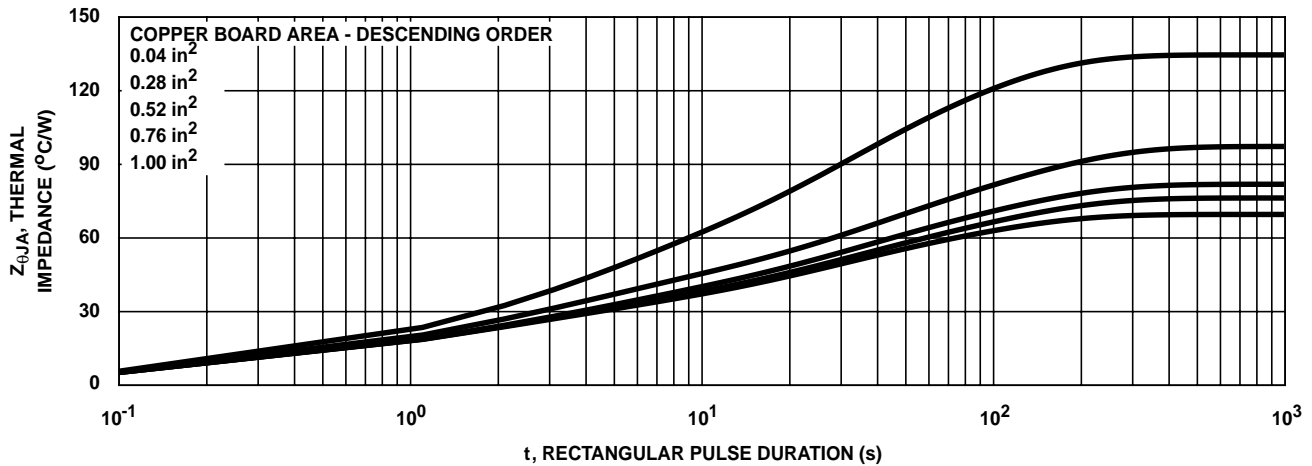

FIGURE 21. THERMAL IMPEDANCE vs MOUNTING PAD AREA

HUF75531SK8

PSPICE Electrical Model

.SUBCKT HUF75531SK8 2 1 3 ; rev 22 Feb 2000

CA 12 8 2.00e-9
 CB 15 14 2.00e-9
 CIN 6 8 1.09e-9

DBODY 7 5 DBODYMOD
 DBREAK 5 11 DBREAKMOD
 DPLCAP 10 5 DPLCAPMOD

EBREAK 11 7 17 18 86.60
 EDS 14 8 5 8 1
 EGS 13 8 6 8 1
 ESG 6 10 6 8 1
 EVTHRES 6 21 19 8 1
 EVTEMP 20 6 18 22 1

IT 8 17 1

LDRAIN 2 5 1.0e-9
 LGATE 1 9 1.12e-9
 LSOURCE 3 7 1.29e-10

MMED 16 6 8 8 MMEDMOD
 MSTRO 16 6 8 8 MSTROMOD
 MWEAK 16 21 8 8 MWEAKMOD

RBREAK 17 18 RBREAKMOD 1
 RDRAIN 50 16 RDRAINMOD 9.30e-3
 RGATE 9 20 1.70
 RLDRAIN 2 5 10
 RLGATE 1 9 11.2
 RLSOURCE 3 7 1.29
 RSLC1 5 51 RSLCMOD 1e-6
 RSLC2 5 50 1e3
 RSOURCE 8 7 RSOURCEMOD 11.35e-3
 RVTHRES 22 8 RVTHRESMOD 1
 RVTEMP 18 19 RVTEMPMOD 1

S1A 6 12 13 8 S1AMOD
 S1B 13 12 13 8 S1BMOD
 S2A 6 15 14 13 S2AMOD
 S2B 13 15 14 13 S2BMOD

VBAT 22 19 DC 1

ESLC 51 50 VALUE={(V(5,51)/ABS(V(5,51)))*(PWR(V(5,51)/(1e-6*125),2))}

.MODEL DBODYMOD D (IS = 1.06e-12 RS = 5.86e-3 TRS1 = 4.97e-5 TRS2 = 2.11e-6 CJO = 1.51e-9 TT = 1.05e-7 M = 0.53)
 .MODEL DBREAKMOD D (RS = 4.45e-1 TRS1 = 1.02e-3 TRS2 = 0)
 .MODEL DPLCAPMOD D (CJO = 1.48e-9 IS = 1e-30 M = 0.78)
 .MODEL MMEDMOD NMOS (VTO = 3.18 KP = 2.55 IS = 1e-30 N = 10 TOX = 1 L = 1u W = 1u RG = 1.70)
 .MODEL MSTROMOD NMOS (VTO = 3.67 KP = 55 IS = 1e-30 N = 10 TOX = 1 L = 1u W = 1u)
 .MODEL MWEAKMOD NMOS (VTO = 2.83 KP = 0.1 IS = 1e-30 N = 10 TOX = 1 L = 1u W = 1u RG = 17.0 Rs = 0.10)
 .MODEL RBREAKMOD RES (TC1 = 1.21e-3 TC2 = 0)
 .MODEL RDRAINMOD RES (TC1 = 1.32e-2 TC2 = 3.21e-5)
 .MODEL RSLCMOD RES (TC1 = 4.00e-3 TC2 = 0)
 .MODEL RSOURCEMOD RES (TC1 = 1.00e-3 TC2 = 0)
 .MODEL RVTHRESMOD RES (TC1 = -2.56e-3 TC2 = -9.91e-6)
 .MODEL RVTEMPMOD RES (TC1 = -2.44e-3 TC2 = 0)

.MODEL S1AMOD VSWITCH (RON = 1e-5 ROFF = 0.1 VON = -6.0 VOFF = -4.0)
 .MODEL S1BMOD VSWITCH (RON = 1e-5 ROFF = 0.1 VON = -4.0 VOFF = -6.0)
 .MODEL S2AMOD VSWITCH (RON = 1e-5 ROFF = 0.1 VON = -3.0 VOFF = 0.0)
 .MODEL S2BMOD VSWITCH (RON = 1e-5 ROFF = 0.1 VON = 0.0 VOFF = -3.0)

.ENDS

NOTE: For further discussion of the PSPICE model, consult **A New PSPICE Sub-Circuit for the Power MOSFET Featuring Global Temperature Options**; IEEE Power Electronics Specialist Conference Records, 1991, written by William J. Hepp and C. Frank Wheatley.

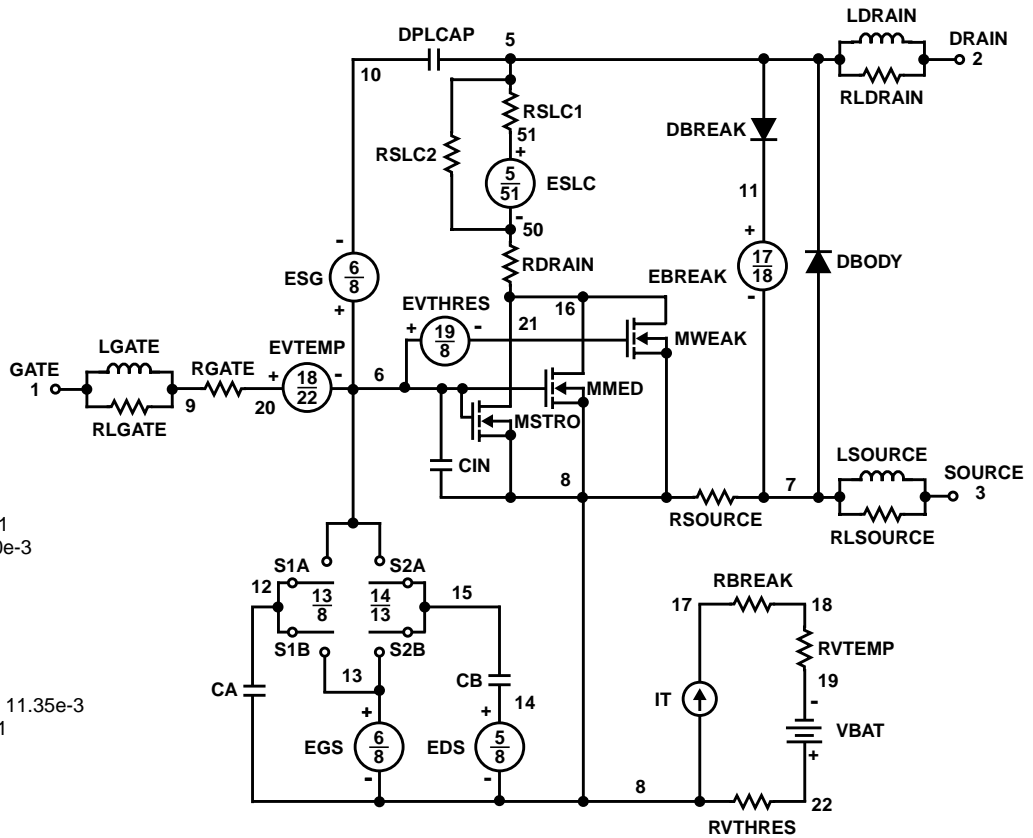

HUF75531SK8

SABER Electrical Model

REV 22 feb 2000

template huf75531sk8 n2,n1,n3
electrical n2,n1,n3

```
{
var i iscl
dp..model dbodymod = (is = 1.06e-12, rs=5.86e-3, trs1=4.97e-5, trs2=2.11e-6, cjo = 1.51e-9, tt = 1.05e-7, m = 0.53)
dp..model dbreakmod = (rs=4.45e-1, trs1=1.02e-3, trs2=0)
dp..model dplcapmod = (cjo = 1.48e-9, is = 1e-30, m = 0.78)
m..model mmedmod = (type=_n, vto = 3.18, kp = 2.55, is = 1e-30, tox = 1)
m..model mstrongmod = (type=_n, vto = 3.67, kp = 55, is = 1e-30, tox = 1)
m..model mweakmod = (type=_n, vto = 2.83, kp = 0.1, is = 1e-30, tox = 1)
sw_vcsp..model s1amod = (ron = 1e-5, roff = 0.1, von = -6.0, voff = -4.0)
sw_vcsp..model s1bmod = (ron = 1e-5, roff = 0.1, von = -.4.0, voff = -6.0)
sw_vcsp..model s2amod = (ron = 1e-5, roff = 0.1, von = -3.0, voff = 0.0)
sw_vcsp..model s2bmod = (ron = 1e-5, roff = 0.1, von = 0.0, voff = -3.0)

```

```
c.ca n12 n8 = 2.00e-9
c.cb n15 n14 = 2.00e-9
c.cin n6 n8 = 1.09e-9

```

```
dp.dbody n7 n5 = model=dbodymod
dp.dbreak n5 n11 = model=dbreakmod
dp.dplcap n10 n5 = model=dplcapmod

```

i.it n8 n17 = 1

```
l.l drain n2 n5 = 1.00e-9
l.l gate n1 n9 = 1.12e-9
l.l source n3 n7 = 1.29e-10

```

```
m.mmed n16 n6 n8 n8 = model=mmedmod, l=1u, w=1u
m.mstrong n16 n6 n8 n8 = model=mstrongmod, l=1u, w=1u
m.mweak n16 n21 n8 n8 = model=mweakmod, l=1u, w=1u

```

```
res.rbreak n17 n18 = 1, tc1 = 1.21e-3, tc2 = 0
res.rdrain n50 n16 = 9.30e-3, tc1 = 1.32e-2, tc2 = 3.21e-5
res.rgate n9 n20 = 1.70
res.rldrain n2 n5 = 10
res.rlgate n1 n9 = 11.2
res.rlsource n3 n7 = 1.29
res.rslc1 n5 n51 = 1e-6, tc1 = 4.00e-3, tc2 = 0
res.rslc2 n5 n50 = 1e3
res.rsources n8 n7 = 11.35e-3, tc1 = 1.00e-3, tc2 = 0
res.rvtemp n18 n19 = 1, tc1 = -2.44e-3, tc2 = 0
res.rvthres n22 n8 = 1, tc1 = -2.56e-3, tc2 = -9.91e-6

```

```
spe.ebreak n11 n7 n17 n18 = 86.60
spe.eds n14 n8 n5 n8 = 1
spe.egs n13 n8 n6 n8 = 1
spe.esg n6 n10 n6 n8 = 1
spe.evtemp n20 n6 n18 n22 = 1
spe.evthres n6 n21 n19 n8 = 1

```

```
sw_vcsp.s1a n6 n12 n13 n8 = model=s1amod
sw_vcsp.s1b n13 n12 n13 n8 = model=s1bmod
sw_vcsp.s2a n6 n15 n14 n13 = model=s2amod
sw_vcsp.s2b n13 n15 n14 n13 = model=s2bmod

```

v.vbat n22 n19 = dc=1

```
equations {
i (n51->n50) +=iscl
iscl: v(n51,n50) = ((v(n5,n51))/(1e-9+abs(v(n5,n51))))*((abs(v(n5,n51))*1e6/125)** 2)
}
}
```

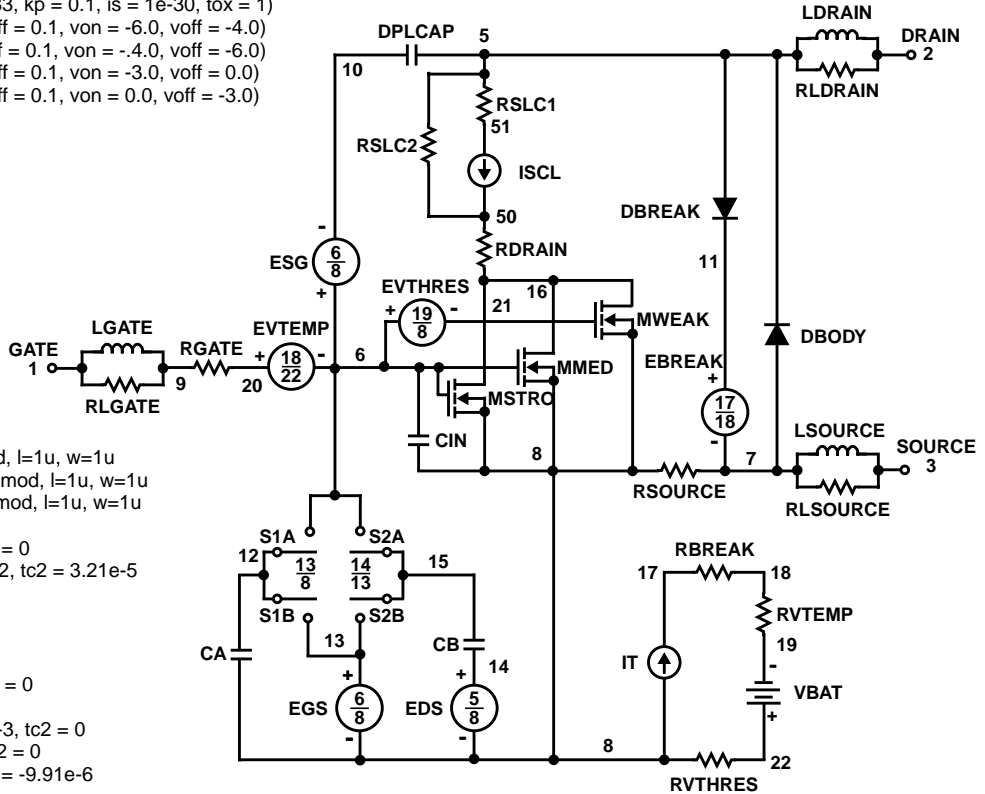

HUF75531SK8

SPICE Thermal Model

REV 12 Feb 2000

HUF75531SK8

Copper Area = 0.04 in²

CTHERM1 th 8 2.0e-3

CTHERM2 8 7 5.0e-3

CTHERM3 7 6 1.0e-2

CTHERM4 6 5 4.0e-2

CTHERM5 5 4 9.0e-2

CTHERM6 4 3 1.2e-1

CTHERM7 3 2 0.5

CTHERM8 2 tl 1.3

RTHERM1 th 8 0.1

RTHERM2 8 7 0.5

RTHERM3 7 6 1.0

RTHERM4 6 5 5.0

RTHERM5 5 4 8.0

RTHERM6 4 3 26

RTHERM7 3 2 39

RTHERM8 2 tl 55

SABER Thermal Model

Copper Area = 0.04 in²

template thermal_model th tl

thermal_c th, tl

```
{
ctherm.ctherm1 th 8 = 2.0e-3
ctherm.ctherm2 8 7 = 5.0e-3
ctherm.ctherm3 7 6 = 1.0e-2
ctherm.ctherm4 6 5 = 4.0e-2
ctherm.ctherm5 5 4 = 9.0e-2
ctherm.ctherm6 4 3 = 1.2e-1
ctherm.ctherm7 3 2 = 0.5
ctherm.ctherm8 2 tl = 1.3

rtherm.rtherm1 th 8 = 0.1
rtherm.rtherm2 8 7 = 0.5
rtherm.rtherm3 7 6 = 1.0
rtherm.rtherm4 6 5 = 5.0
rtherm.rtherm5 5 4 = 8.0
rtherm.rtherm6 4 3 = 26
rtherm.rtherm7 3 2 = 39
rtherm.rtherm8 2 tl = 55
```

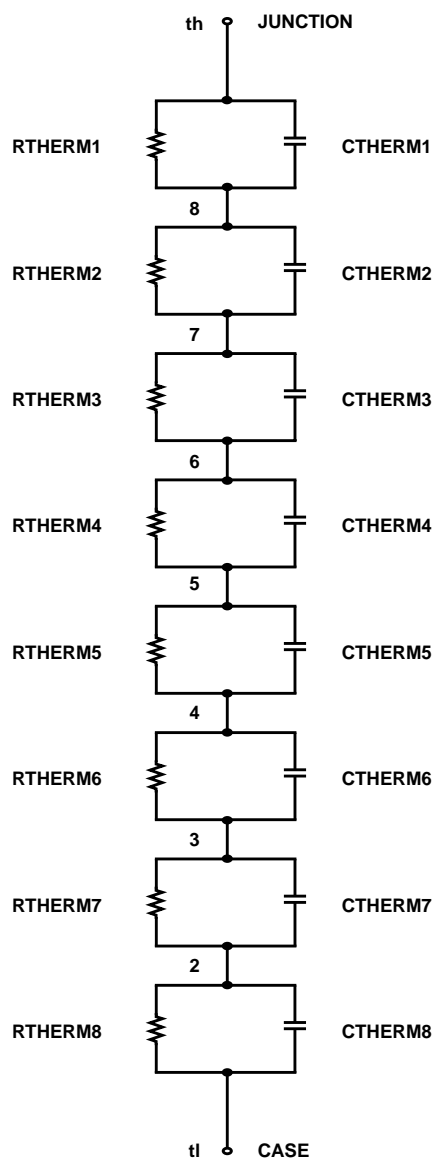

TABLE 1. Thermal Models

COMPONENT	0.04 in ²	0.28 in ²	0.52 in ²	0.76 in ²	1.0 in ²
CTHERM6	1.2e-1	1.5e-1	2.0e-1	2.0e-1	2.0e-1
CTHERM7	0.5	1.0	1.0	1.0	1.0
CTHERM8	1.3	2.8	3.0	3.0	3.0
RTHERM6	26	20	15	13	12
RTHERM7	39	24	21	19	18
RTHERM8	55	38.7	31.3	29.7	25

HUF75531SK8

MS-012AA

8 LEAD JEDEC MS-012AA SMALL OUTLINE PLASTIC PACKAGE

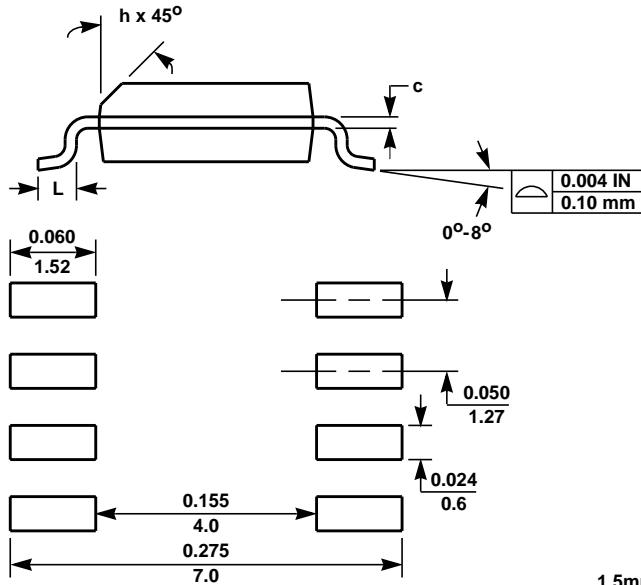
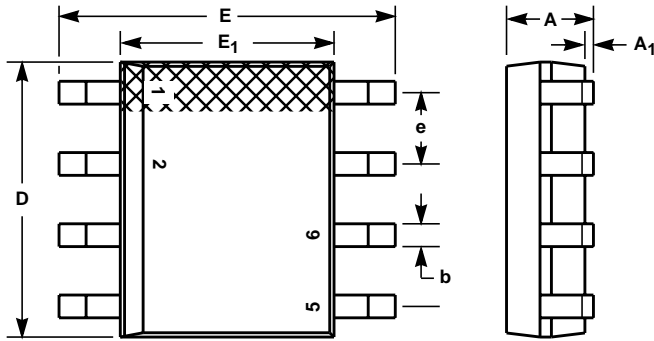

MINIMUM RECOMMENDED FOOTPRINT FOR SURFACE-MOUNTED APPLICATIONS

SYMBOL	INCHES		MILLIMETERS		NOTES
	MIN	MAX	MIN	MAX	
A	0.0532	0.0688	1.35	1.75	-
A ₁	0.004	0.0098	0.10	0.25	-
b	0.013	0.020	0.33	0.51	-
c	0.0075	0.0098	0.19	0.25	-
D	0.189	0.1968	4.80	5.00	2
E	0.2284	0.244	5.80	6.20	-
E ₁	0.1497	0.1574	3.80	4.00	3
e	0.050 BSC		1.27 BSC		-
H	0.0099	0.0196	0.25	0.50	-
L	0.016	0.050	0.40	1.27	4

NOTES:

- All dimensions are within allowable dimensions of Rev. C of JEDEC MS-012AA outline dated 5-90.
- Dimension "D" does not include mold flash, protrusions or gate burrs. Mold flash, protrusions or gate burrs shall not exceed 0.006 inches (0.15mm) per side.
- Dimension "E₁" does not include inter-lead flash or protrusions. Inter-lead flash and protrusions shall not exceed 0.010 inches (0.25mm) per side.
- "L" is the length of terminal for soldering.
- The chamfer on the body is optional. If it is not present, a visual index feature must be located within the crosshatched area.
- Controlling dimension: Millimeter.
- Revision 8 dated 5-99.

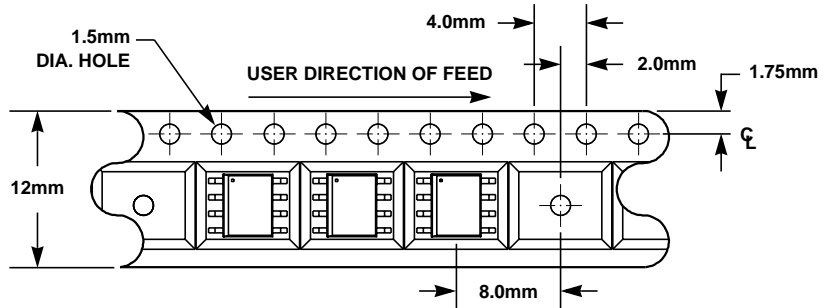

MS-012AA

12mm TAPE AND REEL

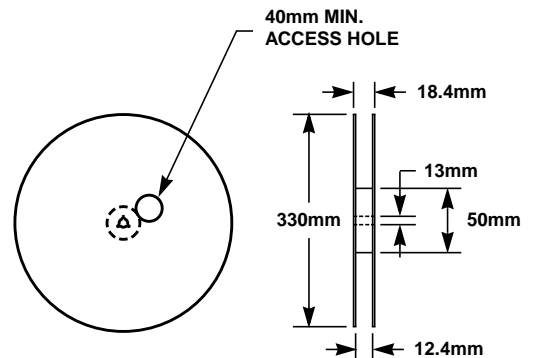
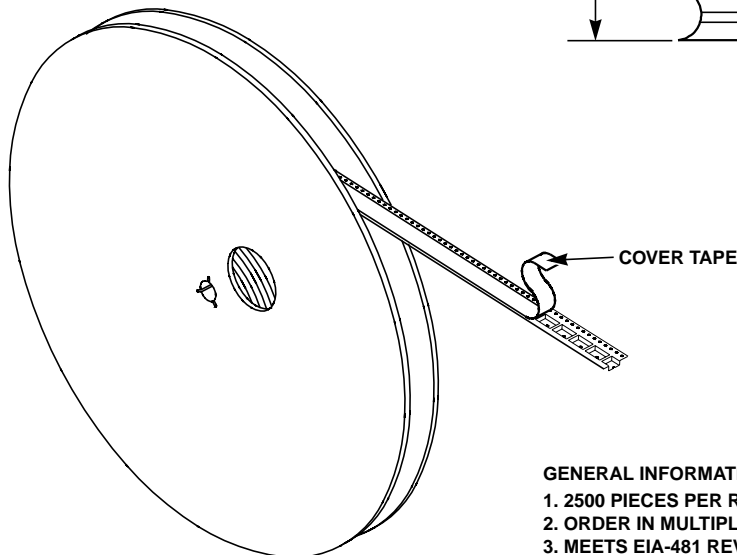

GENERAL INFORMATION

- 2500 PIECES PER REEL.
- ORDER IN MULTIPLES OF FULL REELS ONLY.
- MEETS EIA-481 REVISION "A" SPECIFICATIONS.

All Intersil semiconductor products are manufactured, assembled and tested under **ISO9000** quality systems certification.

Intersil semiconductor products are sold by description only. Intersil Corporation reserves the right to make changes in circuit design and/or specifications at any time without notice. Accordingly, the reader is cautioned to verify that data sheets are current before placing orders. Information furnished by Intersil is believed to be accurate and reliable. However, no responsibility is assumed by Intersil or its subsidiaries for its use; nor for any infringements of patents or other rights of third parties which may result from its use. No license is granted by implication or otherwise under any patent or patent rights of Intersil or its subsidiaries.

For information regarding Intersil Corporation and its products, see web site **www.intersil.com**

Sales Office Headquarters

NORTH AMERICA

Intersil Corporation
P. O. Box 883, Mail Stop 53-204
Melbourne, FL 32902
TEL: (321) 724-7000
FAX: (321) 724-7240

EUROPE

Intersil SA
Mercure Center
100, Rue de la Fusee
1130 Brussels, Belgium
TEL: (32) 2.724.2111
FAX: (32) 2.724.22.05

ASIA

Intersil (Taiwan) Ltd.
7F-6, No. 101 Fu Hsing North Road
Taipei, Taiwan
Republic of China
TEL: (886) 2 2716 9310
FAX: (886) 2 2715 3029