



HV-2405E

World-Wide

Single Chip Power Supply

April 1994

Features

- Direct AC to DC Conversion
- Wide Input Voltage Range.....15Vrms-275Vrms
- Dual Output Voltages Available
- Output Current..... up to 50mA
- Output Voltage..... 5V to 24V
- Line and Load Regulation..... <2%
- UL Recognition, File # E130808

Applications

- Power Supply for Non-Isolated Applications
- Power Supply for Relay Control
- Dual Output Supply for OFF-LINE Motor Controls
- Housekeeping Supply for Switch-Mode Power Supplies

Description

The HV-2405E is a single chip off line power supply that converts world wide AC line voltages to a regulated DC voltage. The output voltage is adjustable from 5V_{DC} to 24V_{DC} with an output current of up to 50mA. The HV-2405E can operate from input voltages between 15Vrms and 275Vrms as well as input frequencies between 47Hz to 200Hz (see Table 1 in section titled "Minimum Input Voltage vs Output Current" for details).

The wide input voltage range makes the HV-2405E an excellent choice for use in equipment which is required to operate from either 240V or 120V. Unlike competitive AC-DC converters, the HV-2405E can use the same external components for operation from either voltage. This flexibility in input voltage, as well as frequency, enables a single design for a world wide supply.

The HV-2405E has a safety feature that monitors the incoming AC line for large dv/dt (i.e. random noise spikes on AC line, initial power applied at or near peak line voltage). This inhibit function protects the HV-2405E, and subsequent circuitry, by turning off the HV-2405E during large dv/dt transients. This feature is utilized to ensure operation within the SOA (Safe Operating Area) of the HV-2405E.

The HV-2405E can be configured to work directly from an electrical outlet (see Figure 1) or imbedded in a larger system (see Figure 7). Both application circuits have components that will vary based on input voltage, output current and output voltage. It is important to understand these values prior to beginning your design.

Ordering Information

PART NUMBER	TEMPERATURE RANGE	PACKAGE
HV3-2405E-5	0°C to +75°C	8 Lead Plastic DIP
HV3-2405E-9	-40°C to +85°C	8 Lead Plastic DIP

CAUTION: This Product Does Not Provide Isolation From The AC line. See "General Precautions". Failure to use a properly rated fuse may cause R1 to reach dangerously High Temperature or Cause the HV-2405E to Crack or Explode.

Pinout

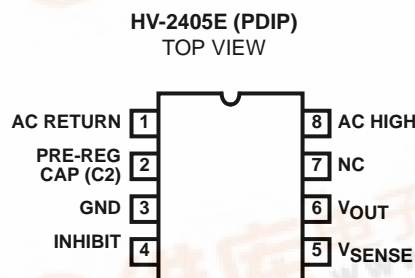

Functional Diagram

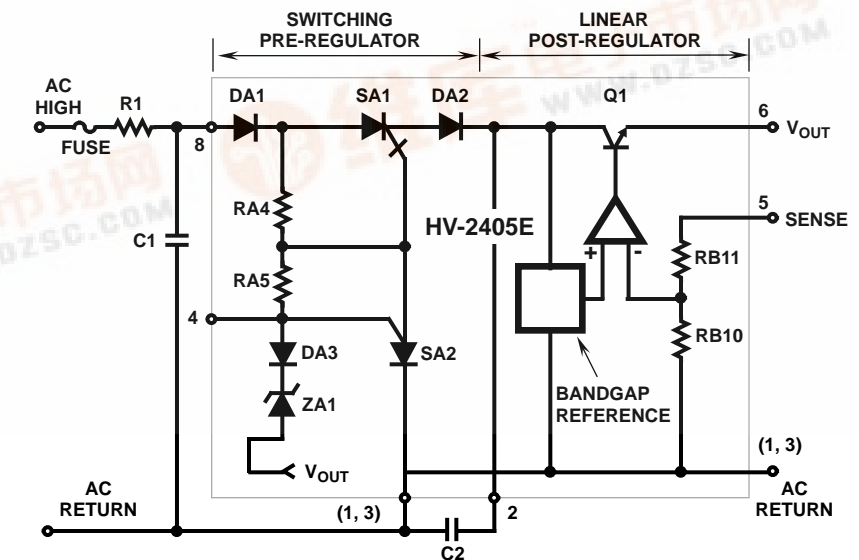

Specifications HV-2405E

Absolute Maximum Ratings

Voltage Between Pin 1 and 8, Peak	±500V
Voltage Between Pin 2 and 6	15V
Input Current, Peak	2A
Output Current	100mA
Output Voltage	34V

Thermal Information

Thermal Resistance	θ_{JA}
Plastic DIP	150°C/W
Maximum Junction Temperature	+150°C
Storage Temperature Range	-65°C to +150°C

CAUTION: Stresses above those listed in "Absolute Maximum Ratings" may cause permanent damage to the device. This is a stress only rating and operation of the device at these or any other conditions above those indicated in the operational sections of this specification is not implied.

Electrical Specifications

Unless Otherwise Specified: $V_{IN} = 264V_{rms}$ at 50Hz, $C1 = 0.05\mu F$, $C2 = 470\mu F$, $C4 = 1\mu F$, $V_{OUT} = 5V$, $I_{OUT} = 50mA$, Source Impedance $R_1 = 150\Omega$. Parameters are Guaranteed at the Specific V_{IN} and Frequency Conditions, Unless Otherwise Specified. See test circuit for Component Location.

PARAMETER	CONDITIONS	TEMP	HV-2405E-5/9			UNITS
			MIN	TYP	MAX	
Output Voltage (At Preset 5V)	$V_{REF} = 0V_{DC}$	+25°C	4.75	5.0	5.25	V
		Full	4.65	5.0	5.35	V
Output Voltage (At Preset 24V)	$V_{REF} = 19V_{DC}$	+25°C	22.8	24.0	25.2	V
		Full	22.32	24.0	25.68	V
Line Regulation	80Vrms to 264Vrms	+25°C	-	10	20	mV
		Full	-	15	40	mV
Load Regulation	$(I_{OUT} = 5mA \text{ to } 50mA)$	+25°C	-	-	20	mV
		Full	-	-	40	mV
Output Current		Full	50	-	-	mA
Output Ripple (Vp-p)		Full	-	24	-	mV
Short Circuit Current Limit		Full	-	70	-	mA
Output Voltage TC		Full	-	0.02	-	%/°C
Quiescent Current Post Regulator	11V _{DC} to 30V _{DC} on Pin 2	+25°C	-	2	-	mA

Test Circuit

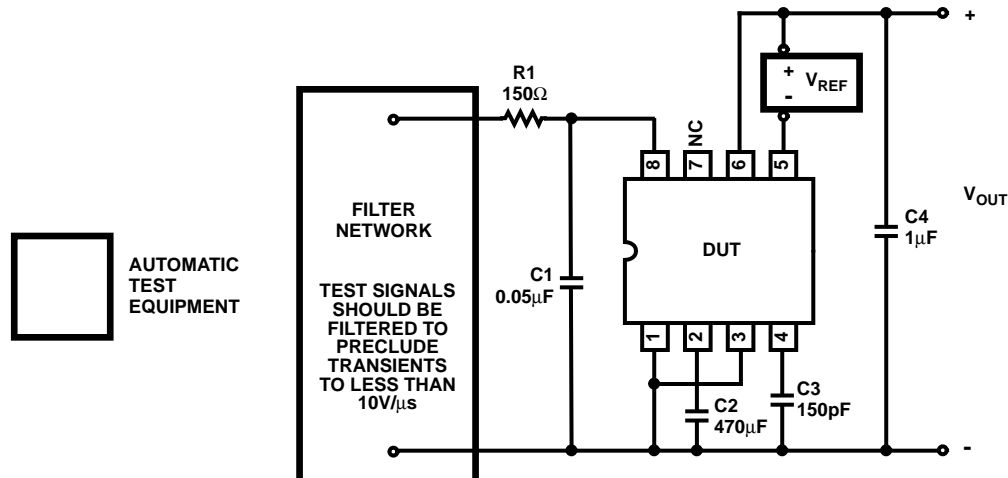

HV-2405E

Application Information

OPERATING CONDITIONS
 $V_{IN} = 50V_{rms}$ TO $275V_{rms}$
FREQUENCY = 50Hz to 60Hz
 $I_{OUT} = 0mA$ to $50mA$
 $V_{OUT} = 5V + V_{Z1}$

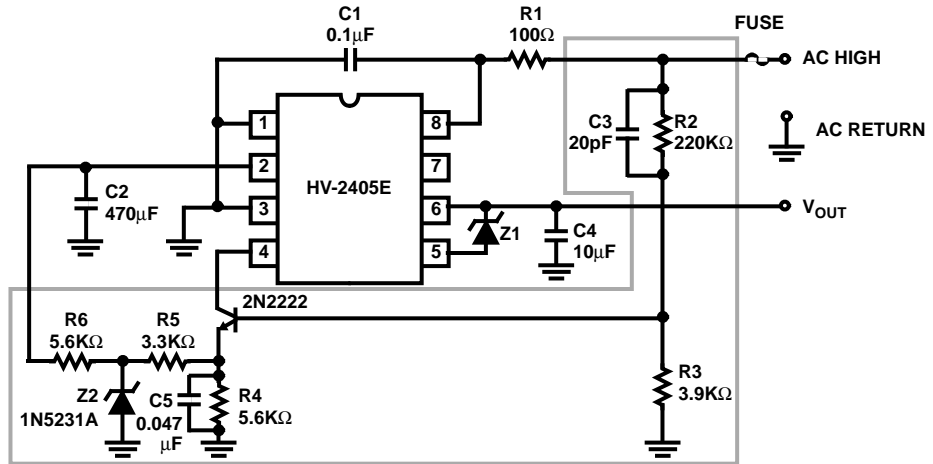

COMPONENT LIST

FUSE = 1/ 4A	C1 = 0.1µF, AC RATED
R1 = 100Ω, 5W	C2 = 470µF, 15V + V_{OUT} , ELECTROLYTIC
R2 = 220kΩ, 1W	C3 = 20pF, CERAMIC
R3 = 3.9kΩ, 1/4W	C4 = 10µF, $V_{OUT} + 10V$, ELECTROLYTIC
R4 = 5.6kΩ, 1/ 4W	C5 = 0.047µF, 10V
R5 = 3.3kΩ, 1/ 4W	Z1 = $V_{OUT} - 5V$, 1/4W
R6 = 5.6kΩ, 1/4 W	Z2 = 5.1V, 1N5231/A OR EQUIVALENT
	Q1 = 2N2222 OR EQUIVALENT

FIGURE 1. OFF LINE WORLD-WIDE SUPPLY ($I_{OUT} \geq 50mA$)

Off line World Wide Supply ($I_{OUT} \leq 50mA$)

Figure 1 shows the recommended application circuit for an off line world wide supply. The circuit will deliver an output voltage of 5V to 24V and an output current from 0 to 50mA. The value of C2 can be reduced for applications requiring less output current (see section titled "Optimizing Design" for details). For a basic understanding of the internal operation of the HV-2405E reference section titled "How the HV-2405E Works".

The following is a detailed explanation of this application circuit:

Basic Operation

When the input voltage goes positive an internal switch connects pin 8 to pin 2 allowing current to flow through R1 to charge up C2. When the voltage on C2 reaches a predetermined voltage the switch opens and the charging of C2 stops. R1 limits the input current and along with C1 provides a snubber for the internal switch. A linear regulator takes current from C2 further regulating the voltage and limiting the ripple at pin 6. The voltage at pin 6 is equal to $V_{Z1} + 5V$. The linear regulator also provides output current limiting. The capacitor C4 on pin 6 is required for stability of the output.

Input Current Limiting Circuit

The external components in the shaded area of Figure 1 perform two functions. The first is to shut down the HV-2405E in the presences of a large voltage transients and the second is to provide input current limiting.

Resistors R2, R3 and capacitor C3 monitor the input voltage and turn on Q1 which shuts down the HV-2405E when the input voltage or the dv/dt is too large. This network anticipates the voltage applied to pin 8, since R1 and C1 add several micro seconds delay, and turns off the HV-2405E when a predetermined input voltage is exceeded. The difference between R3/C3 and R1/C1 time constants ensures that the HV-2405E internal switch opens before the voltage, and thereby the input current, is allowed to rise to a dangerous level at pin 8. The input voltage at which the HV-2405E is turned off, is dependent upon the voltage on C2. The higher the voltage on C2 the larger the input current that the HV-2405E can safely turn off. For a detailed explanation of why the voltage on C2 determines the maximum input current that the HV-2405E can safely turn off, reference "Start-up" in section titled "How the HV-2405E Works".

Input current limiting is provided when the voltage at the base of Q1 forward biases the base to emitter junction, turning off the internal switch. The voltage required at the base to turn on Q1 increases as the voltage on C2 increases the emitter voltage. When the voltage on C2 is $>10V$, the emitter voltage is held constant by Z2 and the maximum input current is set by resistors R2, R3, R4 and R5 (see section titled "Design Equations" for more details).

Operation

The circuit in Figure 1 ensures operation within the SOA of the HV-2405E by limiting the input current to $<500mA$ when the voltage on C2 equals zero and $<2A$ when the voltage on

Application Information (Continued)

C2 is greater than 10V. The circuit's operation is illustrated in Figure 2 and Figure 3. In Figure 2 the initial current pulse is approximately 400mA when $V_{C2} = 0V$ and gradually increases to approximately 1.8A when $C2 = 10V$. Also notice that after the 17th line cycle the input current is approximately 1.4A. At this point C2 is fully charged. The input current required to maintain the voltage on C2 is less than the current to charge it and the circuit has reached steady state operation. Since the steady state current is less than the input current limit, the circuit in the shaded area is off and no longer has any effect.

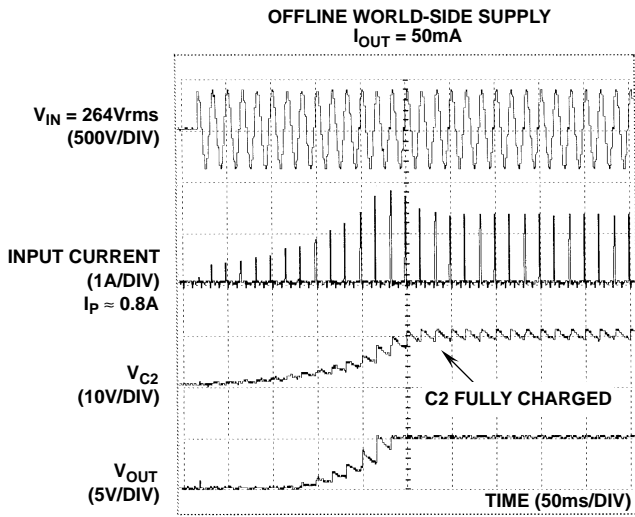

FIGURE 2. START UP OPERATION

Under short circuit operation the maximum voltage on pin 2 is less than 10V and the input current limiting circuit is invoked. Figure 3 shows that under output short circuit conditions, the input current is limited to about 800mA. The effects on the output current when the input current limiting circuit is invoked is illustrated in Figure 6.

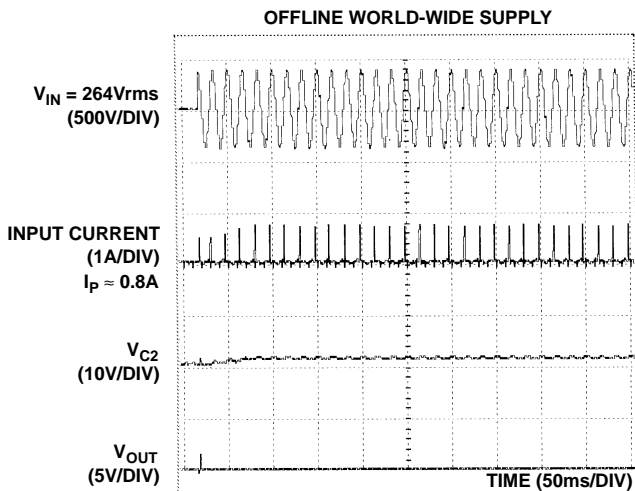

FIGURE 3. SHORT CIRCUIT OPERATION

Design Equations for Input Current Limiting

Initial Start-Up

Assume: $V_{C2} = 0V$, $R1 = 100\Omega$, $R2 = 220k\Omega$, $R3 = 3.9k\Omega$, $R4 = 5.6k\Omega$, $R5 = 3.3k\Omega$, $R6 = 5.6k\Omega$, $V_{BE} = 0.54V$, $I_{TRIG} = 60\mu A$, $V_{Pin 8} - V_{Pin 2} = 3.5V$ at low inputs currents. V_{IN1} = Voltage on AC high when input current limit circuit is invoked ($V_{C2} = 0V$)

$$I_{IN(min)} = \frac{V_{IN1} - V_{Pin 8} - V_{Pin 2}}{R1} \quad (EQ. 1)$$

$$V_{IN1} = \frac{R2 + R3}{R3} \left(V_{BE} + \frac{R4 (R5 + R6)}{R4 + R5 + R6} \times I_{TRIG} \right) \quad (EQ. 2)$$

$$V_{IN1} = 57.41 (0.54 + 3.437k\Omega \times 60\mu A) = 42.84V \quad (EQ. 3)$$

$$I_{IN(min)} = \frac{42.84 - 3.5}{100} = 393mA \quad (EQ. 4)$$

Equation 1 through Equation 4, for the given assumptions, predict that the initial input current will be limited to 393mA.

The following equations can be used to predict the maximum input current during start-up.

Assume: $V_{C2} > 10V$, $R1 = 100\Omega$, $R2 = 220k\Omega$, $R3 = 3.9k\Omega$, $R4 = 5.6k\Omega$, $R5 = 5.6k\Omega$, $R6 = 3.3k\Omega$, $V_{BE} = 0.54V$, $I_{TRIG} = 60\mu A$, $V_Z = 5.1V$, $V_{Pin 8} - V_{Pin 2} = 6V$ at high inputs currents, $V_{Pin 2} - V_{Pin 6}$, V_{IN2} = Voltage on AC high when input current circuit is invoked ($V_{C2} > 10V$).

$$I_{IN(max)} = \frac{V_{IN2} - V_{OUT} - (V_{Pin 8} - V_{Pin 2}) - (V_{Pin 2} - V_{Pin 6})}{R1} \quad (EQ. 5)$$

$$V_{IN2} = \frac{R2 + R3}{R3} \left[\left(V_{BE} + \frac{R4 R5}{R4 + R5} \times I_{TRIG} + \frac{R4}{R4 + R5} V_{Z2} \right) \right] \quad (EQ. 6)$$

$$V_{IN2} = 57.41 [0.54 + (2.076k\Omega \times 60\mu A) + (0.6292 \times 5.1)] \quad (EQ. 7)$$

$$I_{IN(max)} = \frac{222 - V_{OUT} - 6 - 6}{100} = 2.05A \text{ at } V_{OUT} = 5V \quad (EQ. 8)$$

$$I_{IN(max)} = \frac{222 - V_{OUT} - 6 - 6}{100} = 1.86A \text{ at } V_{OUT} = 24V \quad (EQ. 9)$$

Equation 5 through Equation 9 predict the maximum input current will be limited to less than 2.05A. In practice at 5V operation the current is less than predicted due to the low bias current through Z2.

Setting The Output Voltage

The circuit shown in Figure 1 provides a regulated 5V to 24V DC and is set by adjusting the value of Z1. The output voltage of the HV-2405E (pin 6) is set by feedback to the sense pin (pin 5). The output will rise to the voltage necessary to keep the sense pin at 5V. The output voltage is equal to the Zener voltage (V_{Z1}) plus the 5V on the sense pin. For a 5V output, pin 5 and pin 6 would be shorted together. The output voltage has the accuracy and tolerance of both the Zener diode and the band-gap of the HV-2405E (see Figure 16). The maximum output voltage is limited by Z_{B2} to $\approx 34V_{DC}$. Z_{B2} protects the output by ensuring that an overvoltage condition does not exist. Note: the output voltage can also be set by placing a resistor (1/4W) between pin 5 and pin 6. If a resistor is placed between pin 5 and pin 6 an additional 1V per k Ω ($\pm 10\%$) is added to the 5V output.

Application Information (Continued)

Optimizing Design (World-Wide Supply)

Selecting the Storage Capacitor C2

For applications requiring less than 50mA or the full input voltage range, the value of C2 can be reduced for a more cost effective solution. The minimum C2 capacitor value is determined by the intersection between the maximum input voltage and the output current curve in Figure 4. (Note, for 50Hz operation see Figure 19 in section titled "Typical Performance Curves".) Advantages of making C2 as small as possible are:

- Reduced total size and cost of the circuit.
- Reduced start up time.

Consideration should be given to the tolerance and temperature coefficient of the C2 value selected. (Note; momentary peak output current demands should be considered in the sizing of C2. Increasing the output capacitor C4 is another way to supply momentary peak current demands.)

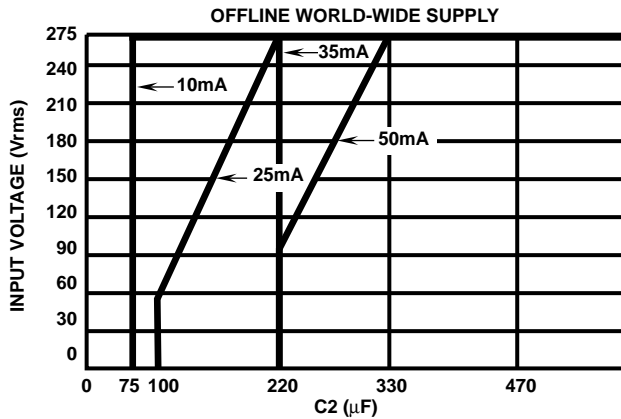

FIGURE 4. MINIMUM C2 VALUE vs INPUT VOLTAGE

The following example illustrates the method for determining the minimum C2 value required:

EXAMPLE

Requirements: $V_{OUT} = 5V$ to $24V$, $I_{OUT} = 35mA$, $V_{IN(max)} = 120V_{rms}$, $60Hz$.

For the given conditions, the minimum C2 value (from Figure 4) is determined to be $220\mu F$.

Determining the Power Dissipation in R1

Circuit efficiency is limited by the power dissipation in R1. The power dissipation for 240Vrms and 120Vrms is shown in Figure 5.

For input voltages other than 240Vrms or 120Vrms equation 10 can be used to determine the power dissipation in R1.

$$P_d = 2.8 \sqrt{R_1 V_{rms} (I_{OUT})^3} \quad (EQ. 10)$$

Example: $R_1 = 100\Omega$, Input Voltage = $240V_{rms}$, $I_{OUT} = 50mA$, $P_D = 4.8W$

NOTE: Under short circuit conditions the P_D in R1 decreases to 1.2W Due to fold back current limiting ($I_{OUT} = 20mA$, Reference Figure 6).

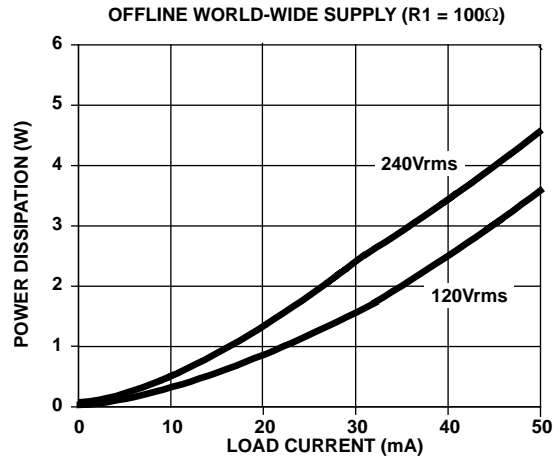

FIGURE 5. POWER DISSIPATION IN R1 vs LOAD CURRENT

Operation Information

Effects of Temperature on Output Current:

Figure 6 shows the effects of temperature on the output current for the circuit shown in Figure 1. Figure 6 illustrates operation with the output configured for 5V. Temperature effects on the output current for $V_{OUT} = 24V$ operation is similar. The foldback current limiting is the result of reduced voltage on C2. The circuit delivers 50mA output current across the specified temperature range of $-40^\circ C$ to $+85^\circ C$ for all output voltages between 5V and 24V. The effect of decreasing the value of C2 ($470\mu F$) reduces the maximum output current (i.e. moves curve to the left). For all C2 values selected from Figure 4 (assuming tolerance and temperature coefficient are taken into account) the circuit meets the expected output current across the above mentioned temperature range.

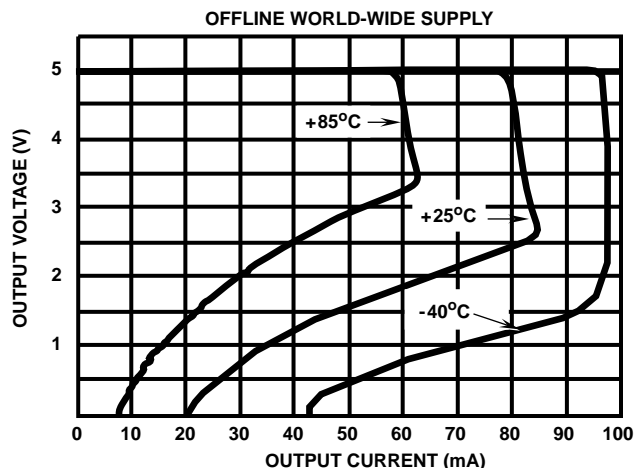

FIGURE 6. OUTPUT CURRENT vs TEMPERATURE

HV-2405E

Application Information (Continued)

Minimum Input Voltage vs I_{OUT}

Table 1 shows the minimum input voltage range as a function of output current. Notice that the HV-2405E can deliver 5V at 10mA from a source voltage as little as 15Vrms and requires a minimum of 50Vrms to deliver 24V at 50mA.

TABLE 1. MINIMUM INPUT VOLTAGE vs OUTPUT CURRENT

V _{OUT}	I _{OUT}			
	10mA	25mA	35mA	50mA
5V	15Vrms	21Vrms	25Vrms	30Vrms
24V	31Vrms	38Vrms	41Vrms	50Vrms

Component List (World Wide Supply <50mA)

Fuse

Opens the connection to the power line.

Recommended value: 1/4AG

R1 Source Resistor

R1 limits the input current into the HV-2405E. Needs to be large enough to limit inrush current when C2 is discharged fully. The maximum inrush current needs to be limited to less than 2A (V peak / R1 <2A). The equation for power dissipation in R1 is:

$$Pd = 2.8 \sqrt{R1 \text{ Vrms} (I_{OUT})^3} \quad (\text{EQ. 10})$$

Wirewound resistors are recommended due to their superior temperature characteristics.

R1 = 100Ω (±10%)

R2, R3, R4, R5 and R6 Resistors

R2, R3, R4, R5 and R6 set the bias level for Q1 that establishes the minimum and maximum input current limit during start-up.

Resistor values (±5%):

R2 = 220kΩ, 1W R5 = 3.3kΩ, 1/4W
 R3 = 3.9kΩ, 1/4W R6 = 5.6kΩ, 1/4W
 R4 = 5.6kΩ, 1/4W

C1 Snubber Capacitor

C1 and R1 form a low pass filter that limits the voltage rate of rise across SA1 (the main current carrying SCR of the HV-2405E) and therefore its power dissipation.

C1 = 0.1μF (±10%) AC rated, metallized polyester.

C2 Pre-Regulator Capacitor

C2 is charged once each line cycle. The post regulator section of the HV-2405E is powered by C2 for most of the line cycle. If the application requires a smaller input voltage, the value of C2 can be reduced from that shown in Figure 1 (see section on "Optimizing Design" for details). Note: capacitors with high ESR may not store enough charge to maintain full load current. The voltage rating of C2 should be about 10V greater than the selected V_{OUT}.

Recommended value = 470μF electrolytic (±20%), unless otherwise specified.

C3 Feed Forward Capacitor

C3 is part of the input Current limiting circuitry shown in Figure 1. C3 detects large voltage transients on the AC line and turns off the HV-2405E by turning Q1 on.

C3 = 20pF (20%), breakdown voltage >500V.

C4 Output Filter Capacitor

C4 is required to maintain the stability of the output stage. Larger values may help in supplying short momentary current peaks to the load and improve output ripple during start-up.

C4 = 10μF (±20%)

Z1 Output Voltage Adjust

Z1 is used to set the output voltage above the 5V reference on pin 5 (see section titled "Setting The Output Voltage" for more details).

Z1 = V_{OUT} - 5V, 1/4W. V2 valve at 1mA.

Note, the wattage rating is different when configured as a dual supply (see dual supply section for on how to determine wattage).

Z2 Clamp Diode

Z2 clamps the voltage on Q1s emitter when the voltage on C2 >10V. This results in limiting the maximum input current to less than 2A.

Z2 = 5.1V, 1N5231A or equivalent

Q1 Input Current Limiting Transistor

Q1 shuts down the HV-2405E when the input voltage or dv/dt is too large.

V_{CEO} = 40V min.

Q1 = 2N2222 or equivalent

Imbedded Supply (I_{OUT} ≤ 30mA)

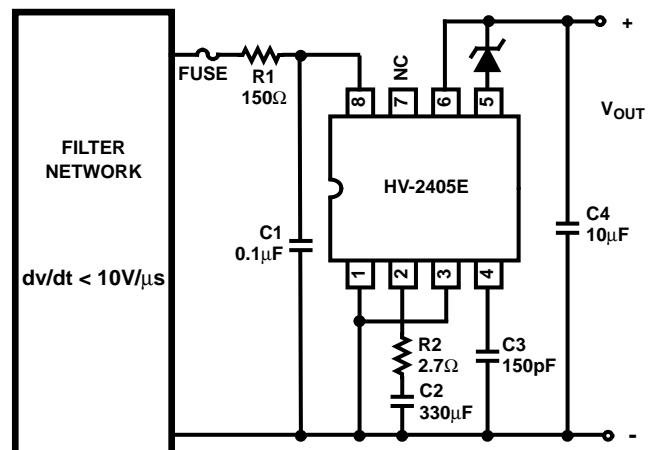

COMPONENT LIST

FUSE = 1/4A C2 = 330μF, 15V + V_{OUT}, ELECTROLYTIC
 R1 = 150Ω, 3W C3 = 150pF, CERAMIC
 R2 = 2.7Ω, 1/4W C4 = 10μF, V_{OUT} + 10V, ELECTROLYTIC
 C1 = 0.1μF, AC RATED Z1 = V_{OUT} - 5V, 1/4W

FIGURE 7. IMBEDDED SUPPLY I_{OUT} ≤ 30mA

HV-2405E

Application Information (Continued)

For applications requiring 30mA or less and not directly off line (i.e. filter network preceding supply), the external transistor and associated resistors in Figure 1 can be replaced with a single 1/4W resistor R2 and capacitor C3 (Figure 7) if: (1) The filter network reduces the input dv/dt to less than 10V/μs (ensures sufficient pin 2 voltage at turn off), (2) Source resistor R1 equals 150Ω (limits the maximum input current) and (3) Inhibit Capacitor C3 equals 150pF (turns off the HV-2405E during large voltage transients).

For applications where EMI (conductive interference) is a design requirement, the circuit shown in Figure 8 is the recommended application circuit. This circuit delivers an output voltage of 5V to 24V with an output current from 0 to 30mA and passes VDE 0871 class "B" test requirements for conductive interference with a resistive load.

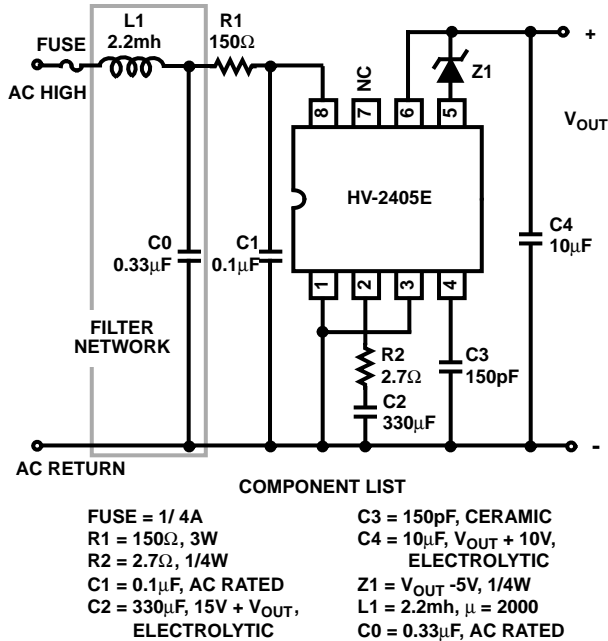

FIGURE 8. IMBEDDED SUPPLY WITH EMI FILTER (I_{OUT} ≤ 30mA)

Basic Operation

When power is initially applied the filter network reduces the magnitude of any transient noise spikes that might result in operation outside the SOA of the HV-2405E (see Start-up in section titled "How the HV-2405E Works" for an explanation of the SOA). When the voltage on pin 8 goes positive an internal switch connects pin 8 to pin 2 and C2 starts to charge through R1 and R2. When the voltage on pin 2 reaches a predetermined voltage the switch opens and the charging of C2 stops. R1 limits the input current and along with C1 provides a snubber for the internal switch. R2 also has the effect of limiting the input current by increasing the voltage on pin 2 sooner in the cycle. A linear regulator takes current from C2 and provides a DC voltage at pin 6. The voltage at pin 6 is equal to V_{Z1} + 5V. The inhibit capacitor (C3) provides protection from large input voltage transients by turning off the HV-2405E and the output capacitor C4 provides stabilization of the output stage.

Operation

The operation of the imbedded supply is illustrated in Figure 9 and Figure 10. Figure 9 shows operation with a 30mA load and Figure 10 with the output short circuited. Notice that In both cases, the inhibit function of the HV-2405E prevents the circuit from turning on when the input voltage was applied near the peak line voltage. Also notice the initial current pulse (Figure 9) is approximately 1.6A and decreased to 1A within 40ms. This decrease in the input current results when the charging current required to maintain the voltage on C2 decreased. The effect of the series resistor (R2) is illustrated by the small voltage spike on the V_{pin 2} trace. This voltage spike increases the voltage on pin 2 to the 10V trip point sooner in the cycle, thereby limiting the input current.

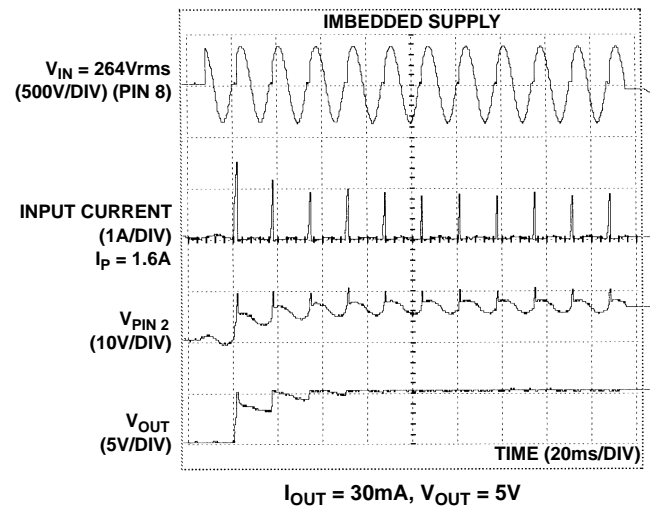

FIGURE 9. START UP OPERATION

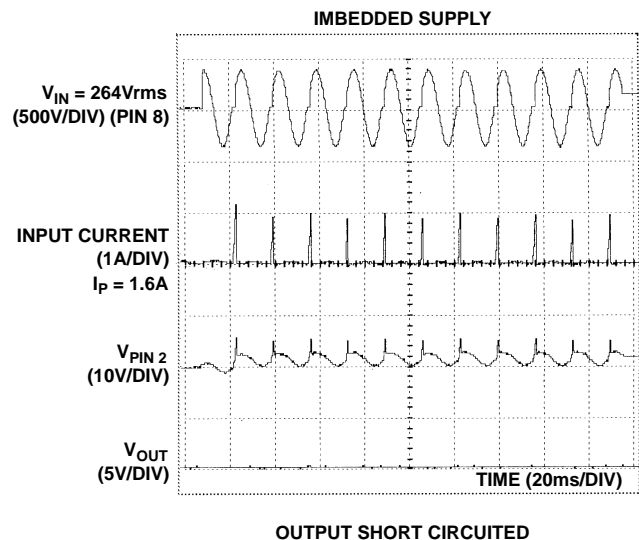

FIGURE 10. SHORT CIRCUIT OPERATION

HV-2405E

Application Information (Continued)

Setting The Output Voltage

The circuits shown in Figure 7 and Figure 8 provide a regulated 5V to 24V_{DC} output voltage that is set by adjusting the value of Z1. The output voltage of the HV-2405E (pin 6) is set by feedback to the sense pin (pin 5). The output will rise to the voltage necessary to keep the sense pin at 5V. The output voltage is equal to the Zener voltage (V_{Z1}) plus the 5V on the sense pin. For a 5V output, pin 5 and pin 6 would be shorted together. The output voltage has the accuracy and tolerance of both the Zener diode and the band-gap of the HV-2405E (see Figure 16). The maximum output voltage is limited by Z_{B2} to $\approx 34V_{DC}$. Z_{B2} protects the output by ensuring that an overvoltage condition does not exist. Note: the output voltage can also be set by placing a resistor (1/4W) between pin 5 and pin 6. If a resistor is placed between pin 5 and pin 6 an additional 1V per k Ω ($\pm 10\%$) is added to the 5V output.

Optimizing Design (Imbedded Supply)

Selecting the storage capacitor C2

For applications requiring less than 30mA, the value of C2 can be reduced for a more cost effective solution. The minimum C2 capacitor value vs. output current is presented in Table 2. Advantages of making C2 as small as possible are:

- Reduced total size and cost of the circuit.
- Reduced start up time.

Consideration should be given to the tolerance and temperature coefficient of the C2 value selected. (Note: momentary peak output current demands should be considered in the sizing of C2. Increasing the output capacitor C4 is another way to supply momentary peak current demands.)

TABLE 2. IMBEDDED SUPPLY

R1 - 150 Ω		R2 = 2.7 Ω	
V _{IN}	FREQ.	C2	I _{OUT}
264Vrms	50Hz	330 μ F	30mA
		220 μ F	24mA
		100 μ F	14mA
		50 μ F	8mA
264Vrms	60Hz	330 μ F	30mA
		220 μ F	27mA
		100 μ F	16mA
		50 μ F	9mA
132Vrms	50Hz	330 μ F	30mA
		220 μ F	30mA
		100 μ F	16mA
		50 μ F	8mA
132Vrms	60Hz	330 μ F	30mA
		220 μ F	30mA
		100 μ F	16mA
		50 μ F	9mA

Determining the Power Dissipation in R1

Circuit efficiency is limited by the power dissipation in R1. The power dissipation for 240Vrms and 120Vrms is shown in Figure 11.

For input voltages other than 240Vrms or 120Vrms Equation 10 can be used to determine the power dissipation in R1.

$$P_d = 2.8 \sqrt{R1 \text{ Vrms}} (I_{OUT})^3 \quad (\text{EQ. 10})$$

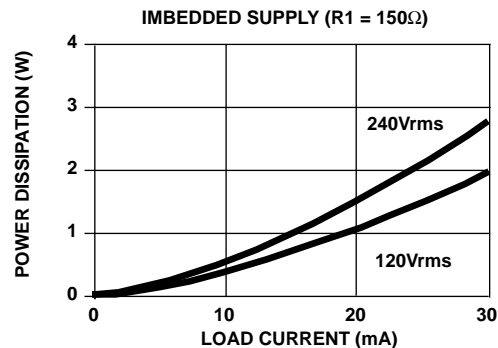

FIGURE 11. POWER DISSIPATION IN R1 vs LOAD CURRENT

Operation information

Effects of Temperature on Output Current

Figure 12 and Figure 13 show the effects of temperature on the output current for the imbedded supply ($R2 = 2.7\Omega$). Figure 12 illustrates $V_{OUT} = 5V$ operation and Figure 13 illustrates $V_{OUT} = 24V$ operation. The imbedded supply ($R2 = 2.7\Omega$) delivers 30mA output current across the specified temperature range of -40°C to $+85^\circ\text{C}$ for all output voltages between 5V and 24V. The effect of decreasing the value of C2 (330 μ F) reduces the maximum output current (i.e. moves curve to the left). For all C2 values selected from Table 2 (assuming tolerance and temperature coefficient are taken into account) the circuit meets the expected output current across the above mentioned temperature range.

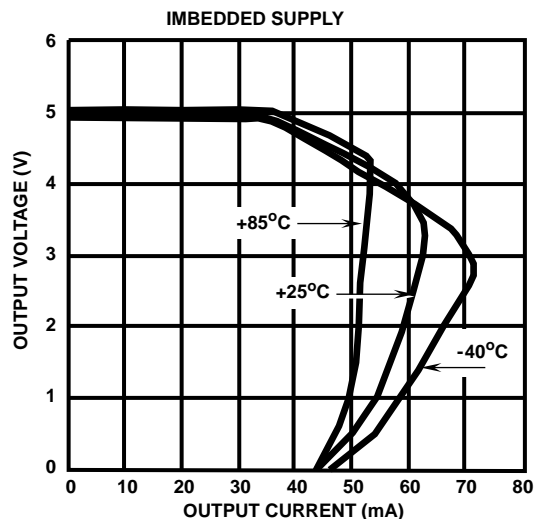

FIGURE 12. OUTPUT CURRENT vs TEMPERATURE (R1 = 150 Ω),

HV-2405E

Application Information (Continued)

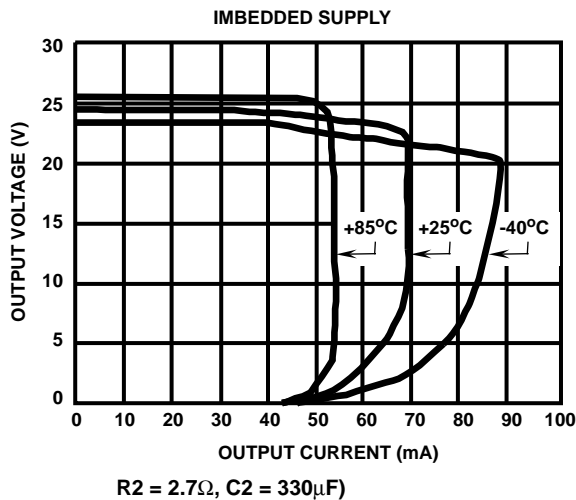

FIGURE 13. OUTPUT CURRENT vs TEMPERATURE (R1 = 150Ω, R2 = 2.7Ω, C2 = 330μF)

Component List (Imbedded Supply ≤30mA)

Fuse

Opens the connection to the power line should the system fail.

Recommended value: 1/4A

R1 Source Resistor

R1 limits the input current into the HV-2405E. Needs to be large enough to limit inrush current when C2 is discharged fully. The maximum inrush current needs to be limited to less than 2A ($V_{peak} / R1 < 2A$). The equation for power dissipation in R1 is:

$$P_d = 2.8 \sqrt{R1 V_{rms} (I_{OUT})^3}$$

Wirewound resistors are recommended due to their superior temperature characteristics.

R1 = 150Ω (±10%)

R2 Series Resistor

R2 limits the input current by boosting the voltage on pin 2 sooner in the cycle.

R2 = 2.7Ω (5%), 1/4W

C1 Snubber Capacitor

C1 and R1 form a low pass filter that limits the voltage rate of rise across SA1 (the main current carrying SCR of the HV-2405E) and therefore its power dissipation.

C1 = 0.1μF (±10%) AC rated, metallized polyester.

C2 Pre-Regulator Capacitor

C2 is charged once each line cycle. The post regulator section of the HV-2405E is powered by C2 for most of the line cycle. If the application requires a smaller input voltage, the value of C2 can be reduced from that shown in Figure 7 or Figure 8 (see section on "Optimizing Design" for details). Note; capacitors with high ESR may not store enough

charge to maintain full load current. The voltage rating of C2 should be about 10V greater than the selected V_{OUT} .

Recommended value = 330μF electrolytic (±20%), unless otherwise specified.

C3 Inhibit Capacitor

C3 keeps the HV-2405E from turning on during large input voltage transients.

C3 = 150pF (10%)

C4 Output Filter Capacitor

C4 is required to maintain the stability of the output stage. Larger values may help in supplying short momentary current peaks to the load and improves output ripple during start-up.

C4 = 10μF (±20%)

Z1 Output Voltage Adjust

Z1 is used to set the output voltage above the 5V reference on pin 5 (see section titled "Setting The Output Voltage" for more details).

Z1 = $V_{OUT} - 5V$, 1/4W

Note, the wattage rating is different when configured as a dual supply (see dual supply section for on how to determine wattage).

Low Input Voltage Supply ($I_{OUT} < 50mA$)

An ideal application, taking advantage of the low voltage operation, would be thermostat controls were 28Vrms is supplied via a transformer. In this application the HV-2405E could deliver a regulated 5V at 40mA with a power dissipation in R1 (R1= 20Ω) equal to 530mw. The current limiting components, in Figure 1, are not required at this low input voltage level. See Figure 23 and Figure 24 for output vs temperature.

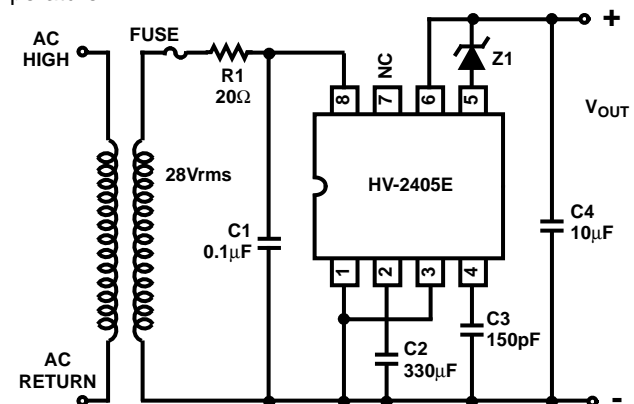

COMPONENT LIST

FUSE = 1/4A, OPTIONAL
R1 = 20Ω, 1W
C1 = 0.05μF, AC RATED
C2 = 330μF, 15V + V_{OUT} , ELECTROLYTIC
C3 = 150pF, CERAMIC
C4 = 10μF, $V_{OUT} + 10V$, ELECTROLYTIC
Z1 = $V_{OUT} - 5V$, 1/4W

FIGURE 14. LOW INPUT VOLTAGE SUPPLY

HV-2405E

Application Information (Continued)

COMPONENT LIST

FUSE = 1/2A
 R1 = 100Ω, 5W
 R2 = 220kΩ, 1W
 R3 = 3.9kΩ, 1W
 R4 = 5.6kΩ, 1/4W
 R5 = 3.3Ω, 1/4W
 R6 = 5.6kΩ, 1/4W
 C1 = 0.1μF, AC RATED
 C2 = 470μF, 15V + V_{OUT}, ELECTROLYTIC
 C3 = 20pF, CERAMIC
 C4 = 10μF, V_{OUT} + 10V, ELECTROLYTIC
 C5 = 0.047μF, 10V
 Z1 = V_{OUT} - 5V, 1/4W
 Z2 = 5.1V, 1N5231/A OR EQUIVALENT
 Q1 = 2N2222 OR EQUIVALENT



FIGURE 15. DUAL SUPPLY

Dual Supply (I_{OUT} < 50mA)

Dual output voltages are available by making use of the 5V reference at pin 5. The sum of both supply currents must not exceed maximum output current limit of 50mA. The output current for the 5V supply is delivered from the output (pin 6) through the Zener diode. The wattage calculation for the Zener diode is given in Equation 11.

$$\text{Wattage} = (V \text{ pin } 6 - V \text{ pin } 5) (I_{\text{OUT}} \text{ pin } 5) \quad (\text{EQ. 11})$$

General Precautions

CAUTION: This product does not provide isolation from the AC line. Failure to use a properly rated fuse may cause R1 to reach dangerously high temperatures or cause the HV-2405E to crack or explode.

Instrumentation Effects

Background:

Input to output parasitic exist in most test equipment power supplies. The inter-winding capacitance of the transformer may result in substantial current flow (mA) from the equipment ground wire to the AC and DC ground of the HV-2405E. This current can induce instability in the inhibit circuit of the HV-2405E resulting in erratic operation.

Recommendations for evaluation of the HV-2405E in the lab:

- The use of battery powered DVMs and scopes will eliminate ground loops.
- When connecting test equipment, locate grounds as close to pin 1 as possible.
- Current measurements on the AC side of the HV-2405E (Pin 8, Pin 1 and Pin 2) should be made with a non-contact current probe.

If AC powered test equipment is used, then the use of an isolated plug is recommended. The isolated plug eliminates any voltage difference between earth ground and AC ground. However, even though the earth ground is disconnected, ground loop currents can still flow through

transformer of the test equipment. Ground loops can be minimized by connecting the test equipment ground probe as close to pin 1 as possible.

Caution: Dangerous voltages may appear on exposed metal surfaces of AC powered test equipment.

AC Source Effects

Background:

Laboratory AC sources (such as VARIACs, step-up transformers etc.) contain large inductances that can generate damaging high voltage transients any time they are switched on or off. Switch arcing can further aggravate the effects of source inductance.

Recommendation:

Adequate protection means (such as MOV, avalanche diode, surge protector, etc.) may be needed to clamp transients to within the ±500V input limit of the HV-2405E.

Output Short Circuited

For output voltages greater than 5V the maximum voltage rating from pin 2 to pin 6 (15V) could be exceeded. For a 24V output the voltage on pin 2 could be as high as 32V. Under normal operating conditions the voltage differential between pin 2 and pin 6 is maintained by DA3, DA4, DA5 and ZA1 (Figure 6) to about 6V. However, if the output (pin 6) is shorted to ground the potential difference would equal the voltage on C2 which would exceed the 15V max limit. (Note: if the output is shorted prior to initial power up, the voltage on C2 only reaches about 6.8V and therefore is not a problem.)

Recommendation:

If the possibility of the output being shorted to ground during normal operation exist, a 10V zener diode (cathode pin 2, anode pin 6) is recommended from pin 2 to pin 6.

HV-2405E

Safe Operating Area

Ensure operation is within the SOA of the HV-2405E. Reference "Start-Up" in section titled "How the HV-2405E Works".

How The HV-2405E Works

Steady State Operation

The HV-2405E converts an AC voltage into a regulated DC voltage. This is accomplished in two functional sections (1) Switching Pre-Regulator and (2) Linear Voltage Regulator. Refer to HV-2405E schematic Figure 16.

The purpose of the Switching Pre-Regulator circuit is to capture energy from an incoming AC power line, 1/6 of every positive half cycle and store this energy in an electrolytic capacitor (C2). This energy is then transferred to the Linear Voltage Regulator. The current path for charging C2 is through DA1, SA1 and DA2. When the voltage level on C2 reaches approximately 6.8V above the output voltage, SA2 turns on turning off SA1 and the charging of C2 stops until the next positive half cycle on AC high. SA2 is triggered on when current flows out of SA2s anode gate and through the Zener diode stack (ZA1, DA3, DA4, DA5). This results in a feedback circuit that limits the peak voltage on pin 2.

The input voltage and current wave forms at pin 8 are illustrated in Photo 1. The operation of the HV-2405E is easily confirmed by noticing the clamping of the input voltage during the charging of C2. Photo 2 shows the voltage on C2 (bottom trace), along with the voltage on pin 8 as a reference. The test conditions for the wave forms are listed at the end of this section.

The Linear Voltage Regulator performs two functions. The first is to provide a reference voltage at pin 5 that is temperature independent and the second is to provide an output voltage on pin 6 that is adjustable from 5V to 24V. The band-gap (NB1, NB2, RB3 and RB4) provides a temperature independent reference voltage on the base of NB5. This reference voltage (1.21V) results in approximately 1mA through RB10 when the feedback loop from pin 6 is closed. The output voltage is adjusted by placing a Zener diode between pin 5 and pin 6. The output voltage on pin 6 is adjusted above the 5V reference on pin 5 by a value equal to the Zener voltage. The maximum output voltage is limited to $\approx 34V_{DC}$ by the internal Zener diode Z_{B2} . Z_{B2} protects the output by ensuring that an overvoltage condition does not exist. The bottom trace of Photo 3 shows the output voltage ripple (worst case conditions), along with the voltage on pin 8 as a reference.

Test conditions for waveforms: $T_A = +25^{\circ}C$, $V_{AC} = 240V_{rms}$, $f = 50Hz$, $R_1 = 150\Omega$, $C_1 = 0.1\mu F$, $C_2 = 470\mu F$, $C_3 = 150pF$, $C_4 = 1\mu F$, $V_{OUT} = 5V$ at 50mA.

Start-up

Start up operation is similar to that described above. Since the storage capacitor connected to pin 2 is discharged, the main SCR, SA1, has to pass more current than for steady state.

The ability of the second SCR, SA2, to turn off SA1 is a function of the voltage on C2. Due to the impedances of SA1 and SA2, the maximum input current that can be safely turned off

decreases for C2 voltages below 5V. To understand why the voltage on C2 determines the maximum input current that the HV-2405E can safely turn off, its important to understand the electrical connection between SA1, SA2 and the storage capacitor C2. Figure 17(A) is a schematic representation of both SCRs and is presented to explain how SA2 turns off SA1.

Top Trace: Input Voltage at Pin 8, AC High (200V/Div)
Bottom Trace: Current into Pin 8, (0.5A/Div)

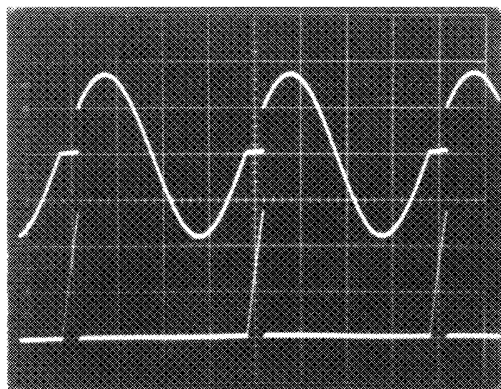

PHOTO 1

Top Trace: Input Voltage at Pin 8, AC High (200V/Div)
Bottom Trace: Pre-Regulator Capacitor Voltage, C2 (5V/Div) at Approximately $10V_{DC}$

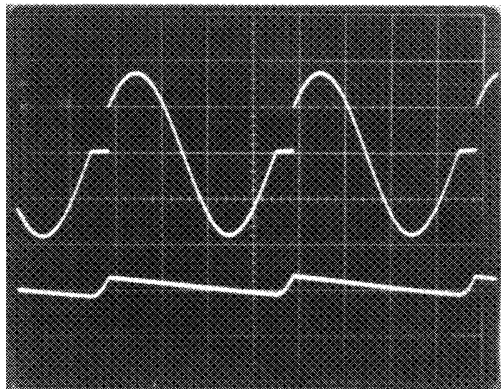

PHOTO 2

Top Trace: Input Voltage at Pin 8, AC High (200V/Div)
Bottom Trace: Ripple or Switch Spike on Regulator $5V_{DC}$ Output (50mV/Div) This is Worst Case Ripple (High Line Voltage, Maximum I_{OUT})

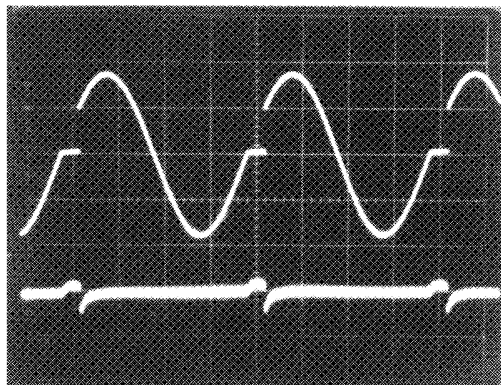

PHOTO 3

HV-2405E

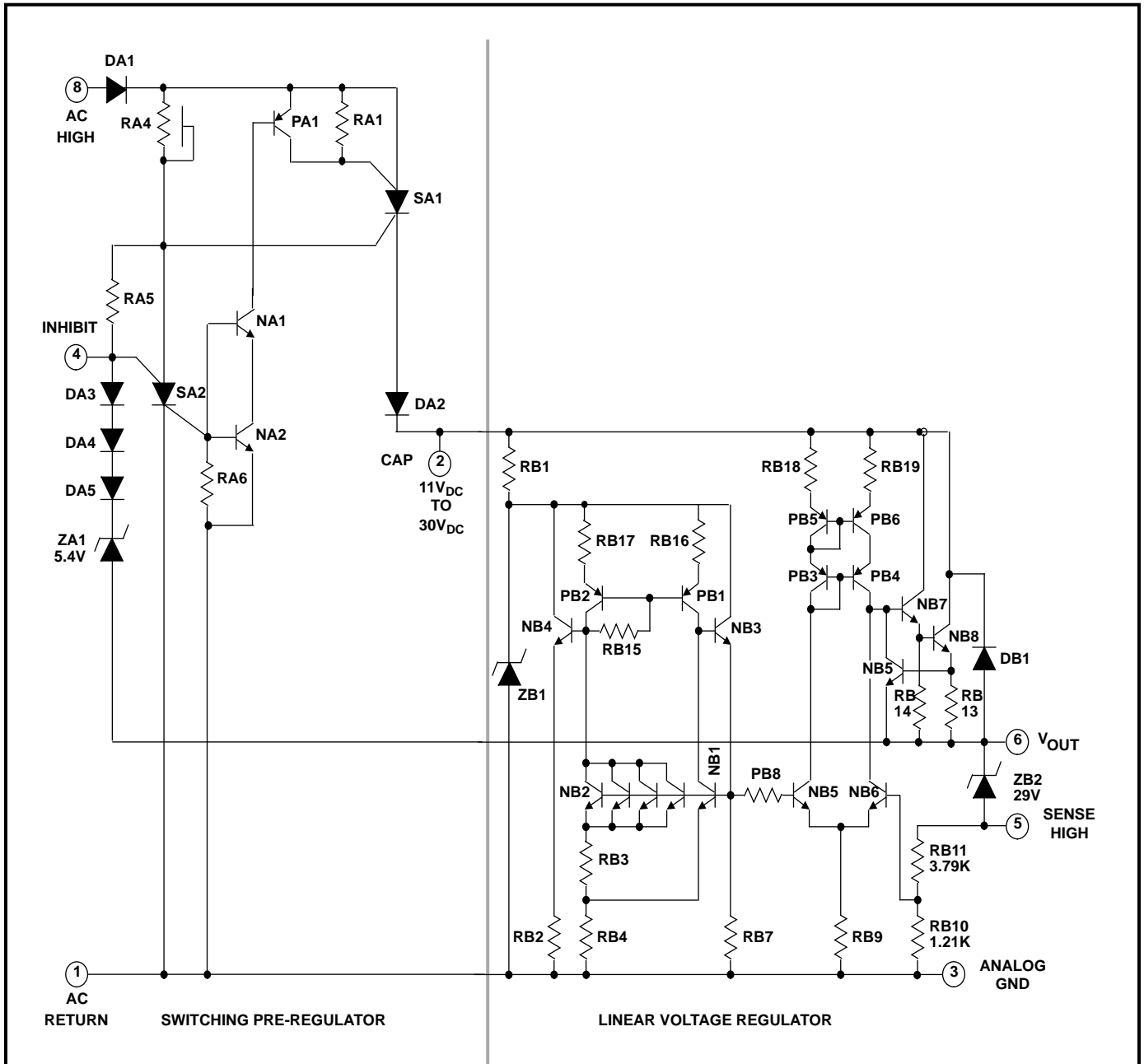

FIGURE 16. HV-2405E SCHEMATIC DIAGRAM

HV-2405E

Assume that SA1 is on and the current path is from pin 8 to pin 2. If a small current is pulled out of the base of SA2s pnp (point 1, Figure 17A) SA2 will turn on. When SA2 turns on the collector current of SA1s pnp no longer provides base drive to its npn and SA1 turns off. Figure 17(B) shows the current relationships for both SCRs.

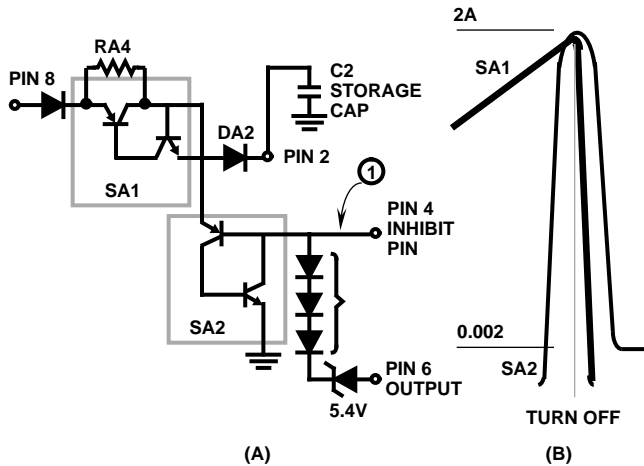

FIGURE 17 (A) (B). SCHEMATIC REPRESENTATION OF SCRs

In order for current to be pulled out of the base of SA2s pnp the voltage on the pnp's emitter will have to be more positive than the voltage on the base. The voltage on the base is referenced 7.5V above the output voltage by the zener diode stack between pin 4 and pin 6. When the voltage on pin 2 reaches 6.8V (7.5V-1V_{be}) above the output voltage, current flows and SA2 is gated on. With 6.8V above the output voltage on C2, there is a sufficient voltage across SA2 to turn off SA1 by sinking 100% of SA1s anode current.

SA2 could be triggered on before C2s voltage is sufficient to ensure that SA2 can sink 100% of SA1s current, by noise on pin 8. In this case SA1 goes into a high impedance state but does not turn off. This condition can exist if switch arcing triggers enough current through the inhibit capacitor to prematurely turn on SA2.

The **Safe Operating Area (SOA)** of the HV-2405E is defined by the voltage on C2 and the magnitude of the input current. Figure 18 shows the safe operating area of the HV-2405E.

Under normal operating conditions the HV-2405E does not turn off the input current until the voltage on C2 is well above 5V. Input currents larger than the safe turn off value in Figure 10 do not present any problems as long as the HV-2405E does not attempt to interrupt them.

During start up operation, power line noise, typically generated by switch bounce/arcing, may accidentally initiate input current turn off before C2 is charged. The application circuit shown in Figure 1 never permits the HV-2405E to operate outside the safe turn off current region so any false turn off signals have no effect. Also, once the capacitor is charged, noise causes no problems.

For applications where there is little noise during start up, the external transistor and associated resistors are not needed. A 150pF capacitor connected to pin 4 helps keep the HV-2405E turned off until any switching noise dies out. Also the input resistor R1 may have to be increased to limit the input current to the allowable maximum.

Some applications inherently have little start-up noise. EMI filters between the power switch and the HV-2405E greatly attenuate switch bounce noise. Likewise, the presences of large capacitors connected through bridge rectifiers act as filters. Solid-state relays that close at the line zero crossing generate little noise. Also, there is no problem if power is applied during the negative part of the line cycle. [The user is cautioned to verify the suitability of his application circuit. Contact Harris Applications for specific questions.]

If the safe turn off current is exceeded, SA1 will fail as a short circuit. However, SA2 will continue to act, temporarily, as shunt regulator to keep the voltage on pin 2 from exceeding the safe limit of the post regulator. The voltage at pin 6 will not change. Failure to use a properly rated fuse may cause R1 to reach dangerously high temperatures or cause the HV-2405E to crack or explode.

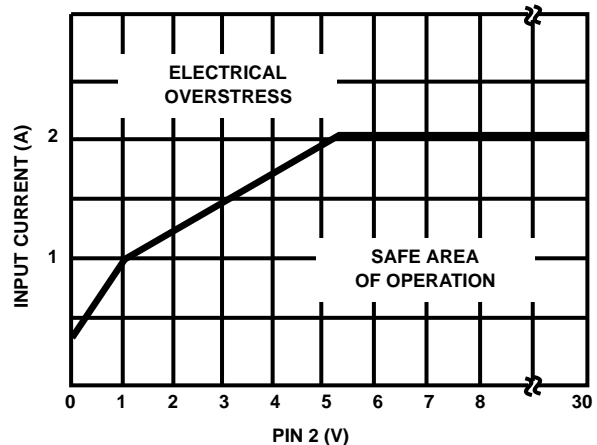

FIGURE 18. HV-2405E SAFE INTERRUPT CURRENT vs PIN 2 VOLTAGE

HV-2405E

Typical Performance Curves

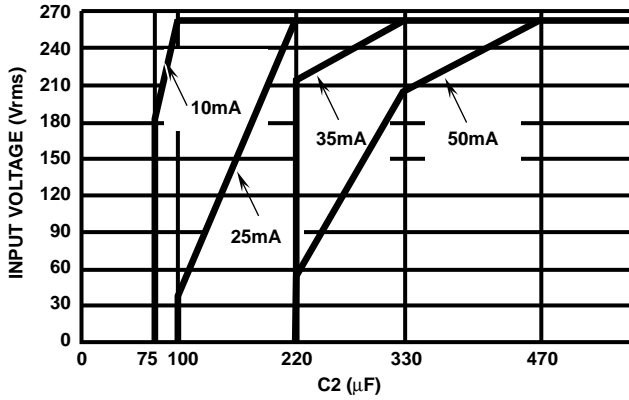

FIGURE 19. MINIMUM C2 VALUE vs INPUT VOLTAGE 50Hz

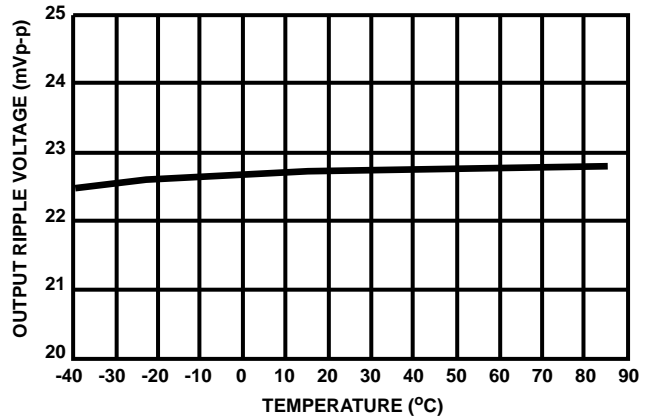

FIGURE 20. OUTPUT RIPPLE VOLTAGE vs TEMPERATURE

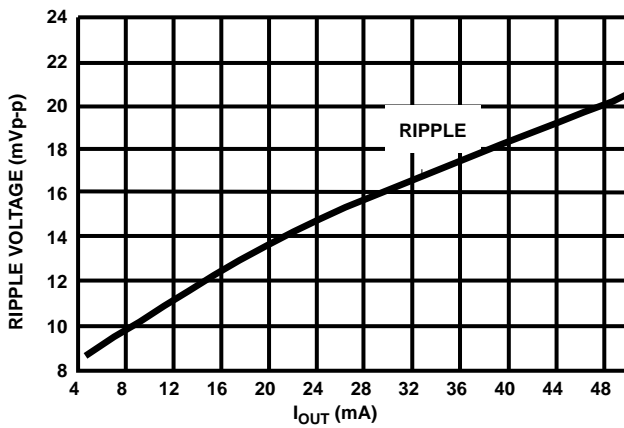

FIGURE 21. OUTPUT RIPPLE VOLTAGE vs LOAD CURRENT

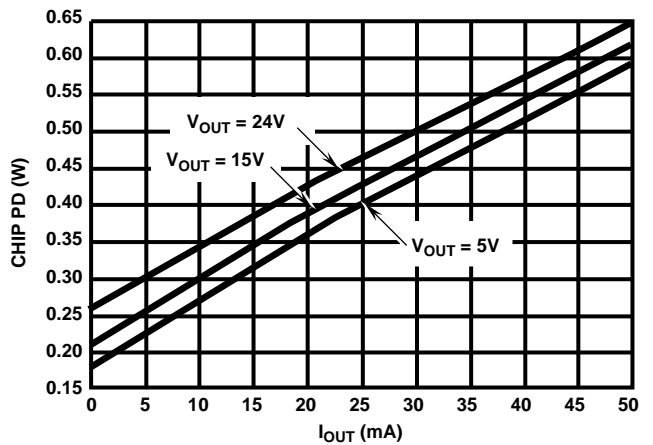

FIGURE 22. CHIP POWER DISSIPATION vs OUTPUT CURRENT

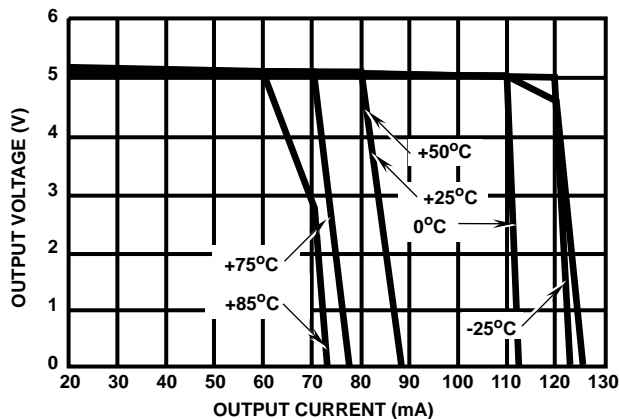

FIGURE 23. OUTPUT CURRENT LIMIT (5V_{OUT}) 50Hz
50mA is the Maximum Recommended Output Current

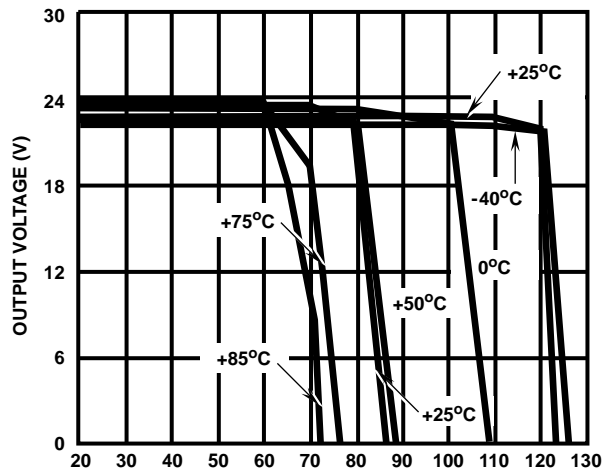

FIGURE 24. OUTPUT CURRENT LIMIT (24V_{OUT}) 50Hz
50mA is the Maximum Recommended Output Current