

Supertex inc.

HV518

32-Channel Vacuum-Fluorescent Display Driver

Ordering Information

Device	Package Options		
	40 Pin Dip	44 Plastic Chip Carrier	Die
HV518	HV518P	HV518PJ	HV518X

Features

- 32 output lines
- 90V output swing
- Active pull-down
- Latches on all outputs
- Up to 6MHz @ $V_{DD} = 5V$
- 40°C to +85°C operation

General Description

The HV518 is designed for vacuum fluorescent or DC plasma applications, where it can serve as a segment, digit or matrix display driver. Each device has 32 outputs, 32 latches and a 32 bit cascadable shift register.

Serial data enters the shift register on the LOW-to-HIGH transition of the clock input. With latch enable (LE) HIGH, parallel data is transferred to the output buffers through a 32-bit latch. When \overline{LE} is low the data is stored in the latch. When STROBE is LOW, all outputs are enabled; if STROBE is HIGH, all outputs are LOW.

Absolute Maximum Ratings

Supply voltage, V_{DD} ¹	-0.5V to +6.0V
Supply voltage, V_{PP} ¹	-0.5V to +90V
Logic input levels ¹	-0.5V to $V_{DD} + 0.5V$
Continuous total power dissipation ^{2,3}	1200mW
Operating temperature range	-40°C to +85°C
Storage temperature range	-65°C to +150°C
Lead temperature 1.6mm(1/16 inch) from case for 10 seconds	260°C

Notes:

1. All voltages referenced to GND.
2. Duty cycle is limited by the total power dissipated in the package.
3. For operation above 25°C ambient, derate linearly to 85°C at 20mW/°C.



Electrical Characteristics

(over recommended ranges of operating free-air temperature and V_{DD} . Unless otherwise noted, $V_{PP} = 80V$)

Symbol	Parameter	Min	Typ	Max	Units	Conditions	
I_{DD}	Supply current			10	mA	$V_{DD} = 5V$, $f_{CH} = 6.0$ MHz	
I_{DDQ}	Quiescent supply current			0.5	mA	$V_{DD} = 5.5V$, $V_{IN} = 0V$	
I_{PP}	Supply current			12	mA	Output high, $T_A = -40^\circ C$	
			7	10	mA	Output high, $T_A = 0$ to $+85^\circ C$	
				500	μA	Outputs low	
V_{OH}	High-level output voltage	HVoutput	70.0		V	$I_{OH} = -25mA$	
		Serial output	4.5	4.9	5	V	$V_{DD} = 5V$, $I_{OH} = -20\mu A$
V_{OL}	Low-level output	HVoutput			5	V	$I_{OL} = 1mA$
		Serial output		0.06	0.8	V	$I_{OL} = 20\mu A$
I_{IH}	High-level logic input current		0.1	1	μA	$V_{IH} = V_{DD}$	
I_{IL}	Low-level logic input current		-0.1	-1	μA	$V_{IL} = 0V$	

Note: The total number of ON outputs times the duty cycle must not exceed the allowable package power dissipation.

Switching Characteristics ($V_{PP} = 80V$, $C_L = 50$ pF, $T_A = 25^\circ C$, unless otherwise noted)

Symbol	Parameter	Min	Max	Unit	Conditions		
t_d	Delay time, Clock to data output	$V_{DD} = 4.5V$		600	ns	$C_L = 15$ pF See Figure 4	
t_{DHL}	Delay time, high-to-low-level, HVoutput	from latch enable	$V_{DD} = 4.5V$		1.5	μs	See Figure 5
		from strobe			1		See Figure 6
t_{DLH}	Delay time, low-to-high-level, HVoutput	from latch enable	$V_{DD} = 4.5V$		1.5	μs	See Figure 5
		from strobe			1		See Figure 6
t_{THL}	Transition time, high-to-low-level, HVoutput	$V_{DD} = 4.5V$		3	μs	See Figure 6	
t_{TLH}	Transition time, low-to-high-level, HVoutput	$V_{DD} = 4.5V$		2.5	μs	See Figure 6	

Recommended Operating Conditions ($T_A = 25^\circ C$, unless otherwise noted)

Symbol	Parameter	Min	Max	Units	
V_{DD}	Logic voltage supply	4.5	5.5	V	
V_{PP}	High voltage supply	8	80	V	
V_{IH}	High-level input voltage (See Fig.3.)	$V_{DD} = 4.5V$	3.5	V	
V_{IL}	Low-level input voltage (See Fig. 3.)	$V_{DD} = 4.5V$	1	V	
I_{OH}	High-level output current		-25	mA	
I_{OL}	Low-level output current		2	mA	
f_{CLK}	Clock frequency (see Figure 3)	$V_{DD} = 4.5V$		6.0	MHz
$t_{w(CKH)}$	Pulse duration, clock high	$V_{DD} = 4.5V$	83	ns	
$t_{w(CKL)}$	Pulse duration, clock low	$V_{DD} = 4.5V$	83	ns	
t_{su}	Setup time, data before clock	$V_{DD} = 4.5V$	75	ns	
t_h	Hold time, data after clock	$V_{DD} = 4.5V$	75	ns	
T_A	Operating free-air temperature	-40	85	$^\circ C$	

Note:

Power-up sequence should be the following:

1. Connect ground.
2. Apply V_{DD} .
3. Set all inputs (Data, CLK, Enable, etc.) to a known state.
4. Apply V_{PP} .
5. The V_{PP} should not drop below V_{DD} or float during operation.

Power-down sequence should be the reverse of the above

Input and Output Equivalent Circuits

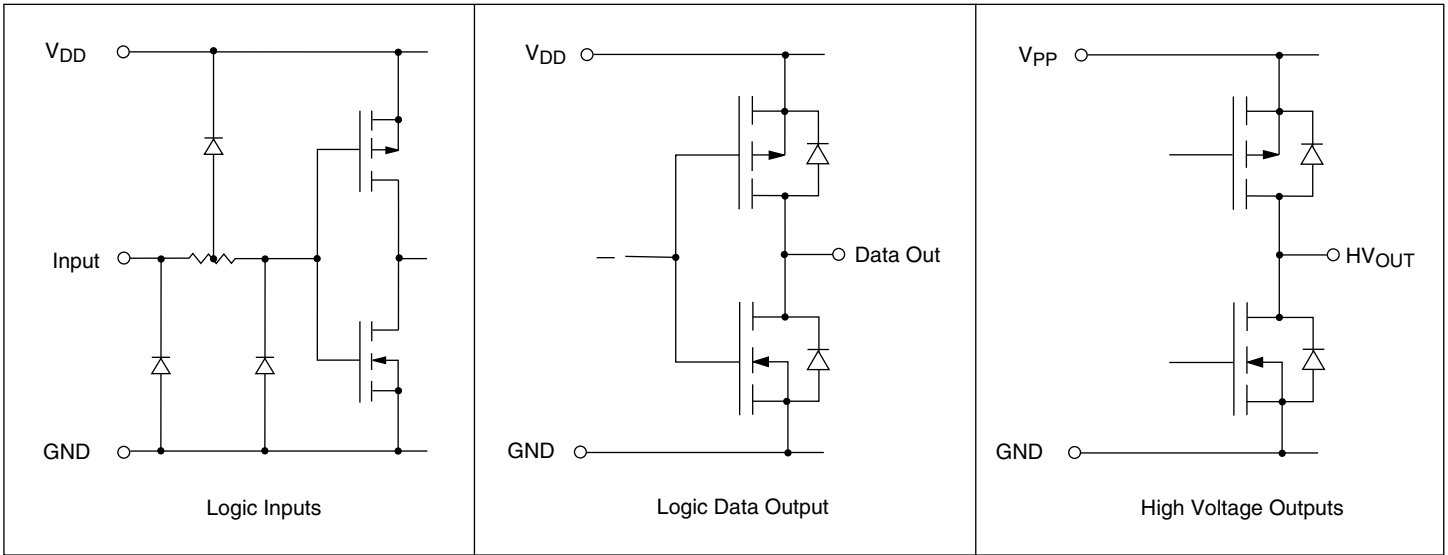

Parameter Measurement Information

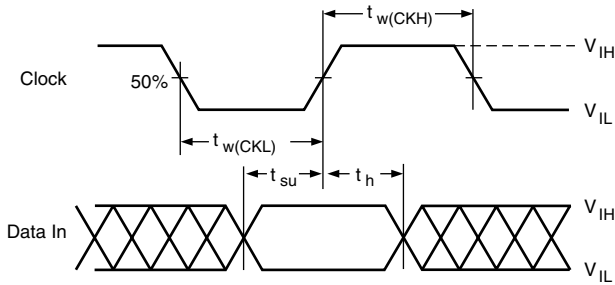

Figure 3: Input Timing Voltage Waveforms

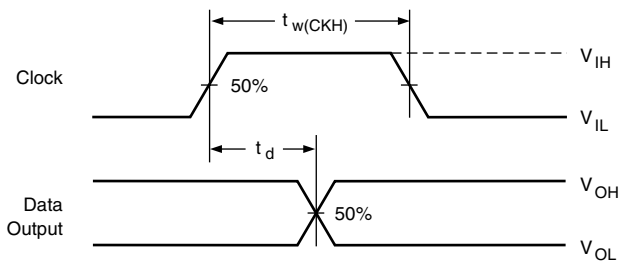

Figure 4

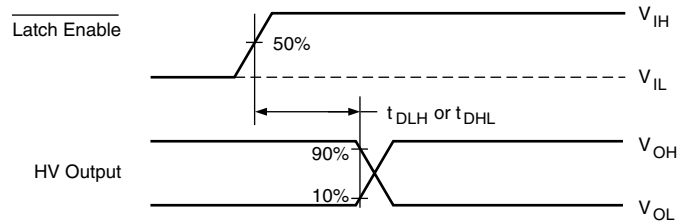

Figure 5

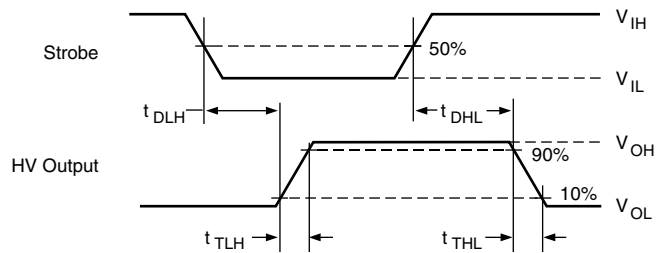
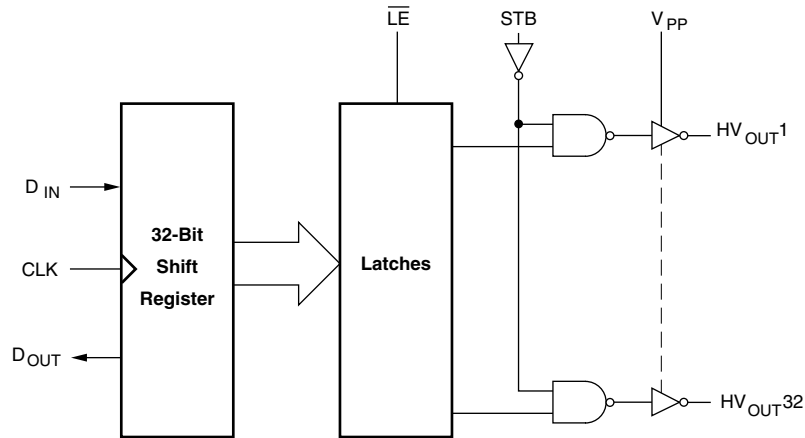

Figure 6: Switching-Time Voltage Waveforms

Note: For testing purposes, all input pulses have maximum rise and fall times of 30 nsec.

Block Diagram



Truth Tables

Input

Data In	CLK	Data Out
H		H
L		L
X	No Change	*

* Previous state

Output

Data In	\overline{LE}	STB	HV Outputs
X	X	H	All Low
H	H	L	High
L	H	L	Low
X	L	L	*

* Previous state

Typical Operating Sequence

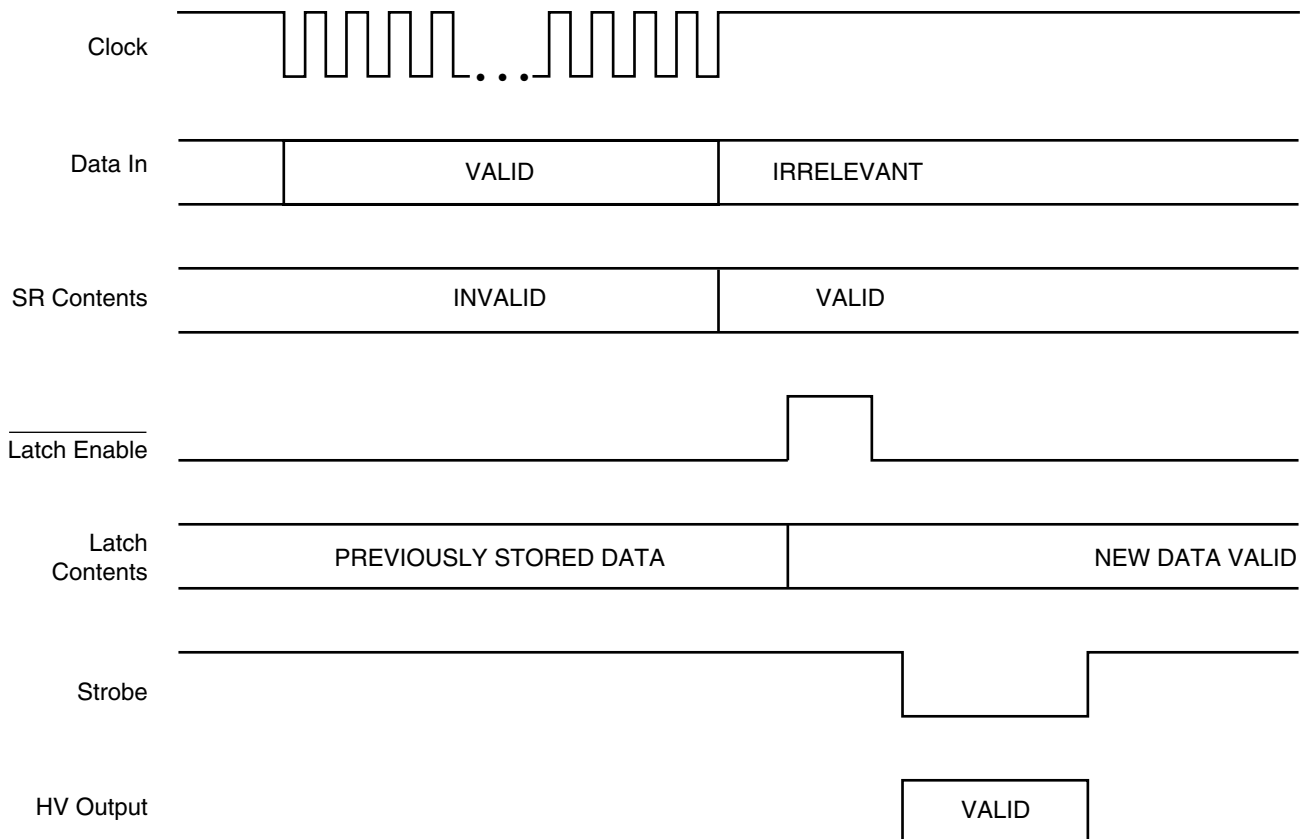

Pin Configurations

Package Outline

HV518

40 Pin Dual-In-Line Package

Pin	Function	Pin	Function
1	V _{PP}	21	Clock
2	Serial Out	22	\overline{LE}
3	HV _{OUT} 32	23	HV _{OUT} 16
4	HV _{OUT} 31	24	HV _{OUT} 15
5	HV _{OUT} 30	25	HV _{OUT} 14
6	HV _{OUT} 29	26	HV _{OUT} 13
7	HV _{OUT} 28	27	HV _{OUT} 12
8	HV _{OUT} 27	28	HV _{OUT} 11
9	HV _{OUT} 26	29	HV _{OUT} 10
10	HV _{OUT} 25	30	HV _{OUT} 9
11	HV _{OUT} 24	31	HV _{OUT} 8
12	HV _{OUT} 23	32	HV _{OUT} 7
13	HV _{OUT} 22	33	HV _{OUT} 6
14	HV _{OUT} 21	34	HV _{OUT} 5
15	HV _{OUT} 20	35	HV _{OUT} 4
16	HV _{OUT} 19	36	HV _{OUT} 3
17	HV _{OUT} 18	37	HV _{OUT} 2
18	HV _{OUT} 17	38	HV _{OUT} 1
19	Strobe	39	Data In
20	GND	40	V _{DD}

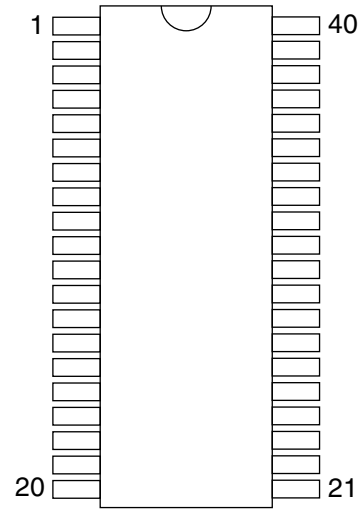

top view
40-pin DIP

HV518

44 Pin J-Lead Package

Pin	Function	Pin	Function
1	V _{PP}	23	Clock
2	Serial Out	24	\overline{LE}
3	HV _{OUT} 32	25	HV _{OUT} 16
4	HV _{OUT} 31	26	HV _{OUT} 15
5	HV _{OUT} 30	27	HV _{OUT} 14
6	N/C	28	N/C
7	HV _{OUT} 29	29	N/C
8	HV _{OUT} 28	30	HV _{OUT} 13
9	HV _{OUT} 27	31	HV _{OUT} 12
10	HV _{OUT} 26	32	HV _{OUT} 11
11	HV _{OUT} 25	33	HV _{OUT} 10
12	HV _{OUT} 24	34	HV _{OUT} 9
13	HV _{OUT} 23	35	HV _{OUT} 8
14	HV _{OUT} 22	36	HV _{OUT} 7
15	HV _{OUT} 21	37	HV _{OUT} 6
16	HV _{OUT} 20	38	HV _{OUT} 5
17	HV _{OUT} 19	39	HV _{OUT} 4
18	N/C	40	HV _{OUT} 3
19	HV _{OUT} 18	41	HV _{OUT} 2
20	HV _{OUT} 17	42	HV _{OUT} 1
21	Strobe	43	Data In
22	GND	44	V _{DD}

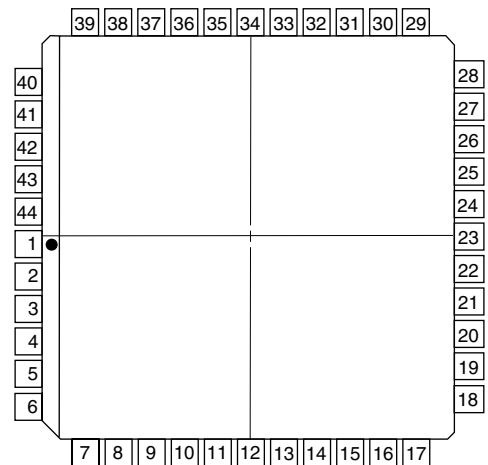

top view