

Advance Information

High Voltage EL Lamp Driver

Features

- ❑ Processed with HVCMOS® technology
- ❑ V_{DD} voltage range = 2.7 to 5.5V DC
- ❑ Output load up to 70nF (20 in² for 3.5nF/in² lamp)
- ❑ Adjustable DC-DC converter frequency
- ❑ Continious output voltage regulation control (from 50V to 200V)

Application

- ❑ Electronic Organizers
- ❑ Handheld Portable Computers
- ❑ Display Signs
- ❑ Portable Instrumentation Equipment

General Description

The Supertex HV829A/B are high voltage EL lamp driver integrated circuits designed for driving EL lamps of up to 70nF at 1000Hz. The input supply voltage range is from 2.7V to 5.5V. These devices use a single inductor, a high voltage switching FET and a minimum number of passive components. The HV829A/B will supply the EL lamp with an AC square wave with a peak-to-peak voltage of two times the set regulated DC voltage.

The HV829A/B has one internal oscillator and a high voltage EL lamp driver. The frequency for the external switching MOSFET is set by an external resistor connected between the R_{SW-osc} pin and GND. The EL frequency for the HV829A is equal to the switching frequency divided by 64 where the EL frequency for the HV829B is equal to the switching frequency divided by 128. Gate of the external MOSFET is connected to the Gate pin. An external inductor is connected between the Drain of external MOSFET and V_{DD} pin. A 0.01-2.5 μ F capacitor is connected between C_S and ground. The EL lamp is connected between V_A and V_B . The output voltage regulation level is controlled via the V_{REG} pin for dimming and/or conservation of power. The output voltage regulation can be controlled continuously between 50V and 200V depending on the voltage applied to V_{REG} pin (0.75V to 3V).

The switching MOSFET charges the external inductor and discharges it into the capacitor at C_S . The voltage at C_S will start to increase. Once the voltage at C_S reaches a nominal value chosen by the user, the switching MOSFET is turned OFF to conserve power. The outputs V_A and V_B are configured as an H bridge and are switching in opposite states to achieve the AC voltage of +/- VREG voltage across the EL lamp.

Typical Application Circuit

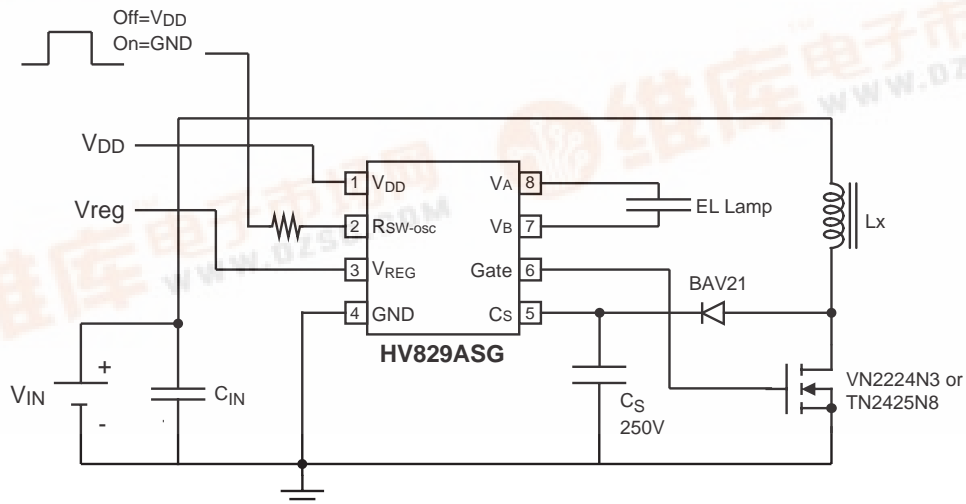

Ordering Information

| Device | Output EL Frequency | Package | |
|--------|---------------------|-------------------|---------|
| | | SO-8 w/ Heat Slug | Die |
| HV829A | Sw oscillator / 64 | HV829ASG | HV829AX |
| HV829B | Sw oscillator / 128 | HV829BSG | HV829AX |

** Mounted on FR4 board, 25mm x 25mm x 1.57mm.

Absolute Maximum Ratings*

| | |
|--|-----------------|
| Input Voltage to the external Inductor | +18V |
| V_{DD} | +7.0V |
| Output voltage, V_{CS} | -.05V to +250V |
| Operating Temperature | -25°C to +85°C |
| Storage Temperature | -65°C to +150°C |
| Power Dissipation | 1.5W |

*Absolute Maximum Ratings are those values beyond which damage to the device may occur. Functional operation under these conditions is not implied. Continuous operation of the device at the absolute rating level may affect device reliability. All voltages are referenced to device ground.

Suggested Pin Configuration

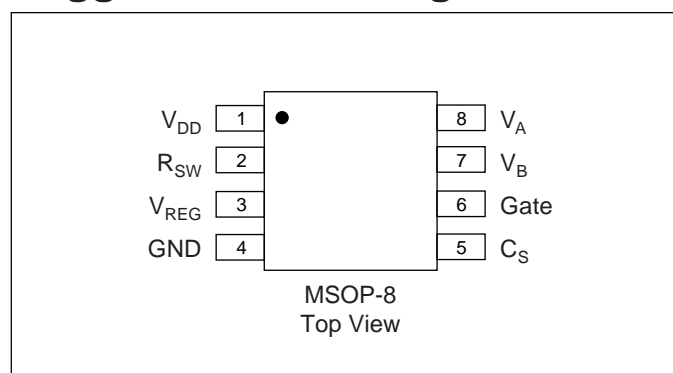

Electrical Characteristics

DC Characteristics (Over recommended operating conditions unless otherwise specified, $T_A=25^\circ\text{C}$).

| Symbol | Parameter | Min | Typ | Max | Units | Conditions |
|-------------|---|-----|-----|-----|---------------|--|
| V_{CS} | Max. output regulation voltage ($V_{DD}=2.7$ to 5.5V , No load) | 42 | 50 | 58 | V | $V_{REG} = 0.75\text{V}$ |
| | | 90 | 100 | 110 | | $V_{REG} = 1.5\text{V}$ |
| | | 135 | 150 | 165 | | $V_{REG} = 2.25\text{V}$ |
| | | 180 | 200 | 220 | | $V_{REG} = 3.0\text{V}$ |
| f_{sw} | Inductor switching frequency | 20 | 25 | 30 | KHz | $V_{CS} = 150\text{V}$, $C_L = 57\text{nF}$, $R_{SW-osc} = 1\text{M}$, See Figure 1. |
| I_{DDQ} | Quiescent V_{DD} supply current | | | 400 | nA | |
| I_{DD} | Input current going into the V_{DD} pin | | | 400 | μA | |
| I_{IN} | Input current including inductor current | | | 195 | mA | |
| I_{INQ} | Quiescent supply current (no load) | | | 200 | μA | $V_{CS} = 150\text{V}$, $R_{SW-osc}=1\text{M}$ |
| | | | | 100 | μA | |
| $V_A - V_B$ | Differential output voltage across the lamp | 84 | 100 | 116 | V | $V_{REG} = 0.75\text{V}$ |
| | | 180 | 200 | 220 | | $V_{REG} = 1.5\text{V}$ |
| | | 270 | 300 | 330 | | $V_{REG} = 2.25\text{V}$ |
| | | 380 | 400 | 440 | | $V_{REG} = 3.0\text{V}$ |

Recommended Operating Conditions

| | | | | | | |
|--------------|------------------------------|------|-----|------|---------------|---|
| f_{sw} | Inductor switching frequency | 51.2 | 64 | 76.8 | KHz | $R_{SW-osc}=400$, $C_L=70\text{nF}$ |
| f_{EL} | Output drive frequency | 0.8 | 1.0 | 1.2 | | |
| t_R | Output rise time | 235 | 300 | 365 | μs | $V_{CS}=200\text{V}$, $R_{SW-osc}=400$, $C_L=70\text{nF}$, $f_{EL}=1\text{KHz}$ |
| t_F | Output fall time | 235 | 300 | 365 | | |
| t_{r-Gate} | Gate rise time | | 150 | | ns | $C_G=2500\text{pF}$ Gate to GND |
| t_{f-Gate} | Gate fall time | | 50 | | | |

Enable/Disable Function Table

| | | | | | | |
|------------|-------------------------|-----|----|-----|-----|--|
| V_{IN} | Inductor voltage | 3.0 | | 12 | V | |
| V_{DD} | device supply voltage | 2.7 | | 5.5 | | |
| V_{GATE} | Internal supply voltage | 10 | 12 | 14 | | |
| C_L | | | | 70 | nF | |
| T_A | Operating temperature | -25 | | 85 | ° C | |

* No I_{Lx} or I_{Cs} current when $V_{DD}=0V$ or Hi-Z

| Description | Input Voltage (V_{DD}) | R_{SW-osc} | Outputs V_A and V_B | Gate |
|-----------------|----------------------------|--------------|-------------------------|-------------|
| Output Disabled | Hi | V_{DD} | Hi-Z | 0V |
| Output Enabled | Hi | GND | Oscillating | Oscillating |
| IC off | 0V | — | Hi-Z | 0V |

Functional Block Diagram

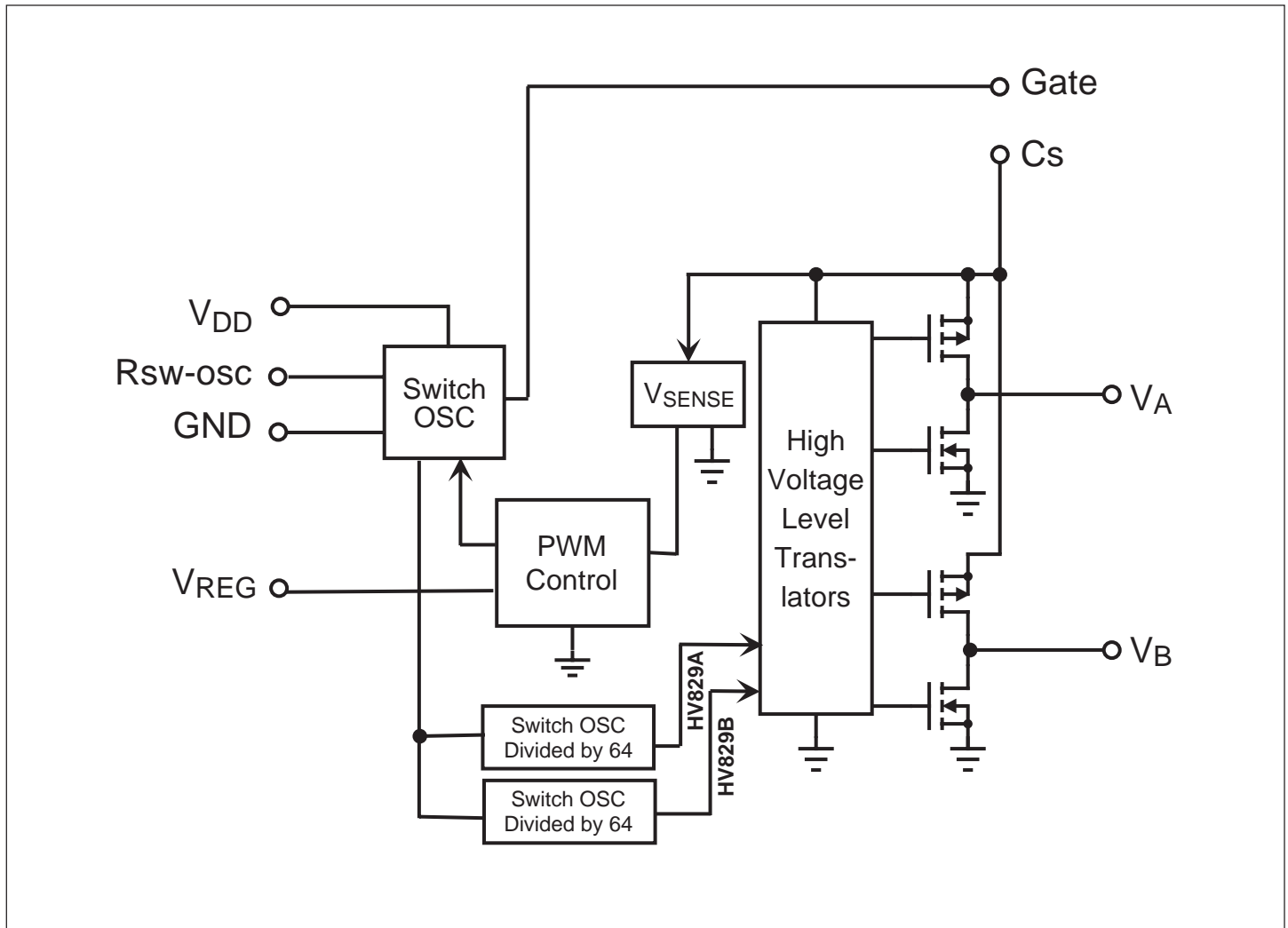
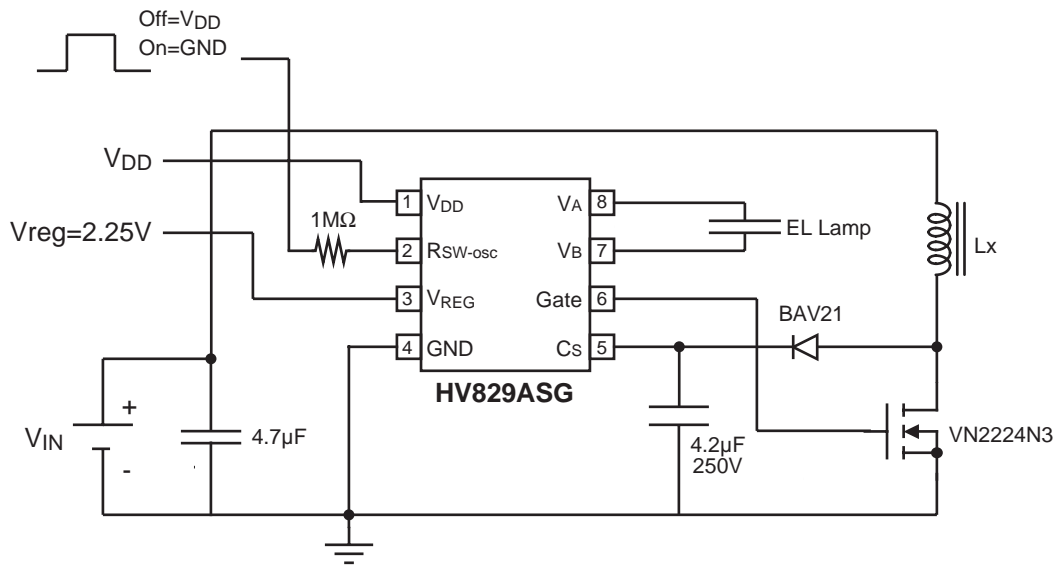

Figure 1: Typical Application/Test Circuit



Typical Performance

| Device | Lamp Size | V _{IN} | I _{DD} | V _{CS} | f _{SW} | f _{EL} | Brightness |
|------------|--------------------|-----------------|-----------------|-----------------|-----------------|-----------------|------------|
| HV829A/BSG | 20 in ² | 9.0V | 195mA | 153V | 25KHz | 390Hz | 18.5ft-lm |

* The inductor used is a 330µH J.W. Miller, max. DC resistance of 1.15Ω, part #PM105-331K.